

ADDENDUM NUMBER 1

**Town of Caryville
Caryville-Jacksboro Utilities Commission**

**2023 ARC Ershell Collins Industrial Park Elevated Tank
Project No. 23 TN-21186**

**TO: ALL INTERESTED PARTIES CONCERNING THE BID DOCUMENTS FOR THE 2023
ARC ERSHELL COLLINS INDUSTRIAL PARK ELEVATED TANK PROJECT**

ITEM I: Response to bidder question/concern:

Delete Paragraph 13415-1.01-B(2) in its entirety and insert the following:

13415-1.01-B(2):

“As providing a safe work environment is critical for this project, to be approved to bid on this project, all tank contractors are required to provide a copy of their written safety program including the responsible party(s) for safety practices with their Bid Proposal.”

ITEM II: Tank vents, overflow pipe, and drain pipe discharge shall include 24-mesh, 316 SST screens. Screens on the overflow pipe and drain discharge shall be installed between 2 flanges or other approved method.

ITEM III: Delete Section 02713, Water Lines, Valves, and Appurtenances and add Section 02713R, Water Lines, Valves, and Appurtenances. Clarifications have been added to the water main disinfection, Bac-T testing, and pressure/leakage testing requirements.

ITEM IV: Response to bidder question/concern:

Due to the environmental requirements related to coating the new tank (see Specification Section 09915) a Contract time extension or Stop Work Order will be considered, for coating operations only, should weather conditions delay the coating operations. No additional payment will be made should the delay be requested and approved. Should the delay be necessary, all other project appurtenances shall be in place and operational, other than items on the tank that may be impacted by the painting operations. The tank and site must be secure prior to demobilization from the site.

ITEM V: Delete Plan Sheets 2, 3, and 11 and insert the attached revised Plan Sheets 2, 3, and 11. The following revisions are included on the sheets:

Sheet 2: Added Note 7 under the Piping Notes.

Sheet 3: Added a yard hydrant on the Yard Piping Plan.

Sheet 11: Added a yard hydrant detail.

THIS ADDENDUM SHALL BECOME A PART OF THE PROJECT MANUAL AND HAVE FULL EFFECT AS IF SUBMITTED WITH THE ORIGINAL DOCUMENTS.

May 2, 2024
Date

/s/ Franklin D. Wallace, Executive Secretary
Caryville-Jacksboro Utilities Commission

SECTION 02713-R

WATER LINES, VALVES, AND APPURTENANCES

PART 1 - GENERAL

1.01 RELATED WORK

- A. Section 01050: Field Engineering
- B. Section 01090: Reference Standards
- C. Section 01150: Measurement and Payment
- D. Section 01340: Shop Drawings, Product Data, and Samples
- E. Section 01530: Barriers
- F. Section 01570: Traffic Regulations
- G. Section 01720: Project Record Documents
- H. Section 02100: Erosion Control
- I. Section 02221: Trenching, Backfilling, and Compacting
- J. Section 02485: Seeding
- K. Section 13415: Multi-Column Elevated Water Storage Tank

1.02 QUALITY ASSURANCE

- A. The Contractor shall install, test, and disinfect water lines in accordance with regulations issued by the Tennessee Department of Environment and Conservation and the Caryville-Jacksboro Utilities Commission.
- B. The Contractor shall disinfect all potable water lines, fittings, valves, and appurtenances in accordance with regulations issued by the Tennessee Department of Environment and Conservation and Caryville-Jacksboro Utilities Commission. Disinfection and bacteriological testing shall comply with AWWA 651-Disinfection of Water Mains.
- C. Adequate numbers of skilled workmen, who are thoroughly trained and experienced in the necessary crafts and who are completely familiar with the specified requirements and the methods needed for proper performance of the work in this section shall be used.
- D. Equipment adequate in size, capacity, and numbers to accomplish the work in a timely manner shall be used.

1.03 REFERENCES

- A. ASTM 2241: Poly (Vinyl Chloride) (PVC) Pipe (SDR-PR).
- B. AWWA C104: Cement-Mortar Lining for Cast-Iron and Ductile-Iron Pipe and Fittings for Water.
- C. AWWA C110/C153 - Gray Iron and Ductile-Iron Fittings, 3 in. through 48 in. for Water and other Liquids.
- D. AWWA C111 - Rubber Gasket Joints for Cast-Iron and Ductile-iron Pressure Pipe and Fittings.
- E. AWWA C151 - Ductile-Iron Pipe Centrifugally Cast, in Metal Molds or Sand-Lined Molds, for Water or Other Liquids.
- F. ASTM D2412: Standard Test Method For Determination of External Loading Characteristics of Plastic Pipe By Parallel-Plate Loading.
- G. ASTM D1784: Rigid PVC Compounds and Chlorinated PVC Compounds
- H. ASTM F477: Elastomeric Seals For Joining Plastic Pipe
- I. ASTM B88 - Seamless Type K Copper Water Tube.
- J. AWWA C500: Gate Valves
- K. AWWA C508: Swing Check Valves
- L. AWWA C700: Cold Water Meters - Displacement Type
- M. AWWA C701: Cold Water Meters - Turbine Type for Customer Service
- N. AWWA C901: Polyethylene Tubing
- O. AWWA C504: Butterfly Valves
- P. AWWA C502: Fire Hydrants
- Q. AWWA C651: Disinfection of Water Mains
- R. ASTM F877: Standard Specification for Cross-Linked Polyethylene Plastic (PEX) Hot and Cold Water Distribution Systems
- S. Other AWWA and ASTM Standards as referenced herein.

1.04 SUBMITTALS

- A. Submittals shall be submitted as specified in Section 01340, promptly and in accordance with the approved schedule, in such a sequence that no delay to the work, or to the work of other Contractors is caused.
- B. Product data shall be submitted as required.
- C. Certification signed by manufacturer and Contractor that pipe and fittings meet specification requirements shall be submitted.

- D. Submit all data for pipes, fittings, gaskets, restrainers, valves, saddles, and other components of the new water system.
- E. Five (5) certified copies of disinfection test results for potable water lines shall be submitted.

1.05 PRODUCT DELIVERY, STORAGE, AND HANDLING

- A. Ductile iron pipe shall be protected from damage to coating and lining.
- B. PVC piping shall be stored to protect from long-term exposure to direct sunlight and shall be stacked in suitable support systems to prevent buckling and deformation.
- C. Interior of pipe and fittings shall be cleaned of dirt and other foreign material immediately prior to lowering into the trench.
- D. Carefully examine each pipe and fitting for cracks and other defects while suspended above the trench immediately before installation.

1.06 JOB CONDITIONS

- A. Whenever pipe laying is not actively in progress, open ends of all installed pipe and fittings shall be fitted with a watertight plug.
- B. Separation of Water Mains and Sewers:
 - 1. The new water main has been located so that the proper horizontal and vertical separation from the existing sewers has been provided where the water line parallels a sewer line. However, in the event field conditions reveal that a horizontal separation of 10 feet cannot be obtained, the water line shall be laid in a separate trench or on an undisturbed earth shelf located on one side of the sewer so that the bottom of the water main is at least 18 inches above the top of the sewer pipe.
 - 2. Whenever the water main crosses a sewer main, a minimum vertical distance of 18 inches shall be provided between pipes. This distance shall be provided whether the water main is above or below the sewer pipe. At crossings, one full length of water pipe must be located so both joints will be as far from the sewer line as possible. Special structural support for the water and sewer lines shall be provided.
 - 3. Water lines shall not pass through or come in contact with storm or sanitary sewer manholes.
- C. Inside pipe shall be properly supported and aligned in accordance with the plans.
- D. Air piping shall have proper expansion/contraction provisions.

PART 2 - PRODUCTS

2.01 GENERAL PIPING AND VALVE APPLICATIONS

- A. Unless otherwise depicted on the accompanying Drawings, the following piping and valve applications apply for this project.
1. All buried non-chemical piping four (4") inch through twelve (12") inch shall be Pressure Class 350 ductile iron pipe with mechanical joint or push-on joint ends or Polyvinyl Chloride Pipe (PVC) ASTM D-2241 SDR17, as specified on accompanying Drawings. Fittings shall be ductile iron with mechanical joint ends for pipe sizes forty-eight (48") inches and smaller and with push-on ends for pipe sizes fifty-four (54") inches and larger. Restrained joints shall be used where noted on the accompanying Drawings.
 2. All buried valves shall be as depicted on the accompanying Drawings.
 3. All interior and above-ground valves shall be as depicted on the accompanying Drawings.
 4. All buried ductile iron pipe and fittings shall be wrapped in V-Bio polyethylene encasement or approved alternate. Encasement shall meet the requirements of ANSI/AWWA C105/A21.5, be a minimum of 8 mils thick, and shall be installed in accordance with Modified Method A (single tube per length of pipe/fitting with a minimum 12-inch overlap at joints).

2.02 DUCTILE IRON PIPE AND FITTINGS

- A. General
1. Ductile iron pipe (DIP) shall be centrifugally cast meeting the requirements of ANSI/AWWA Standard C151/A21.51. Pressure Classes as described in ANSI/AWWA Standard C151 shall be used unless indicated otherwise on the Drawings.
 2. The manufacturer of the DIP shall furnish a sworn, notarized statement that the inspection and specified tests required under section 5.1.1.2 of AWWA /ANSI standard C151/A21.51 have been made and that all results thereof comply with this standard.
 3. One (1) copy of written transcripts of the results of the acceptance tests and low temperature impact tests on pipe manufactured for use in performing the scope of work described in these Specifications shall be furnished to the Engineer.
 4. The weight, class, or nominal thickness, and casting period for each length of ductile iron pipe shall be shown on each length of DIP. The manufacturer's mark, country where cast, year in which the pipe was produced, and the letters "DI" or "DUCTILE" shall be cast or metal stamped on the pipe. All required markings shall be clear and legible, and all cast or metal-stamped marks shall be on or near the bell.

5. Approved Manufacturers:
 - a. U.S. Pipe Company
 - b. American Ductile Iron Pipe Company
 - c. Griffin Pipe Products
 - d. McWane Ductile Iron Pipe Company
- B. DIP Piping Installed Outside Above-Ground and Inside Structures
1. All ductile iron pipe installed outside above ground and inside structures shall conform to the wall thickness requirements of Thickness Class 52 and shall be flanged and shall conform to the requirements of AWWA/ANSI Standard C151/A1.15. Unless otherwise shown, flanges shall be dimensioned for facing and drilling in accordance with ASME/ANSI Standard B16.1 Class 125 and meeting the dimensional and bolting requirements of AWWA Standard C110/A21.10, Table 14. Bolts, gaskets, and installation of flanged DIP and ductile iron fittings shall comply with the requirements of AWWA/ANSI Standard C111/A21.1, Appendix B.
 2. The outside of ductile iron pipe and fittings for installation outside above-ground or inside structures shall be provided to the job site prime coated as specified in Section 09910 of these Specifications.
 3. Buried DIP Piping
 - a. All buried ductile iron pipe shall conform to the wall thickness requirements of Pressure Class 350 and shall have mechanical joints or push-on joints in accordance with AWWA/ANSI Standard C111/A21.11.
 - b. The inside of all DIP for potable water service shall be cement mortar lined in accordance with AWWA/ANSI C104/A21.4
 - c. Fittings for all buried DIP shall be delivered to the project site with their exterior coated with asphaltic material at least one (1) mil thick that conforms to all appropriate requirements at AWWA/ANSI Standard C104/A21.4.
 - d. Fittings for all DIP installed outside above-ground or inside structures flanges shall be dimensioned for facing and drilling in accordance with ASME/ANSI Standard B16.1 Class 125 and meeting the dimensional and bolting requirements of AWWA Standard C110/A21.10, Table 14. Bolts, gaskets, and installation of flanged DIP and ductile iron fittings shall comply with the requirements of AWWA/ANSI Standard C111/A21.1, Appendix B.
Fittings shall be delivered to the project site with their exterior prime coated as described at Section 09910 of these Detailed Specifications.
 - e. Fittings for buried DIP pipelines shall be ductile iron and furnished with ductile iron mechanical joint retainer glands suitable for a working pressure of 75 psi plus a surge allowance of 75 psi. Ductile iron mechanical joint retainer glands shall be manufactured by American Cast Iron Pipe Company, EBAA Iron Sales, Inc., or approved equal. All set screws on the retainer glands shall be tightened, in the presence of the Owner's Representative, using a torque wrench to the

manufacturer's recommended torque. As an alternate to ductile iron mechanical joint fittings with ductile iron retainer glands, the contractor may furnish ductile iron fittings with Field Lok™ gaskets manufactured by United States Pipe and Foundry Company, or Fast-Grip® gaskets manufactured by American Cast Iron Pipe Company, both suitable for a working pressure of 100 psi plus a surge allowance of 100 psi.

- f. Ductile iron fittings meeting the requirements of AWWA/ANSI Standard C110/A21.10 shall have distinctly cast on them the pressure rating, nominal diameters of openings, manufacturer's identification, the country where cast, and the number of degrees or fraction of the circle on all bends and the letters "DI" or "DUCTILE". Cast letters and figures shall be on the outside body of the fitting and shall have dimensions no smaller than the following:

Size (in.)	Height of Letters (in.)	Relief (in.)
Less than 8	As large as practical	As large as practical
8-10	¾	3/32
12-48	1 ¼	3/32

- g. Ductile iron fittings meeting the requirements of AWWA/ANSI Standard C153/A21.53 shall have distinctly cast on the outside of the body AWWA/ANSI C153/A21.53; the pressure rating; nominal diameter of openings; manufacturer's identification; the country where cast; the letters "DI" or word "DUCTILE"; and the number of degrees or fraction of the circle.

2.03 POLYVINYL CHLORIDE (PVC) PIPE AND FITTINGS

- A. General
 - 1. All polyvinyl chloride (PVC) pipe shall meet ASTM D2241, ASTM D1784 Cell Class 12454, with gaskets meeting ASTM F477 and joints meeting ASTM D3139 with an SDR of 17, unless otherwise specified.
 - 2. All pipe must meet a 250 psi working pressure rating and shall be IPS. Pipe shall be clearly marked with the manufacturer's name, nominal diameter, SDR, pressure rating, and NSF approval seal.
- B. Fittings
 - 1. All fittings shall be ductile iron, AWWA C10 or AWWA C115, pressure rating as required.
 - a. Fittings shall be flanged for inside work and mechanical joints for underground.
 - b. Lining shall be cement mortar, AWWA C104.

- c. All piping shall be connected to fittings using a restrained system equal to:
 - 1. Midco Perma-Grip Restrained Joint System as manufactured by Midland.
 - 2. Manufacturing Company, or Uni-Flange Series 1300 restraint for PVC Pipe as manufactured by Ford Meter Box Company.
- C. Joints
 - 1. All joints shall be push-on joints with gaskets as recommended by manufacturer for the application.
- D. See 2.01-A(4) above for fitting protection.

2.04 WATER SERVICE PIPE

- A. Water service lines 1-1/2" and smaller shall be PEX-a, certified to AWWA C904, rated for 160 psi.
- B. Pipe shall be approved for use with AWWA C800 fittings.
- C. Service pipe shall be used to connect the mains to the meter assemblies.
- D. Pipe shall be 3/4 inch, unless otherwise specified or shown on the plans.

2.05 CORPORATION VALVE

- A. Corporation valves shall comply with AWWA C800.
- B. Valves shall be watertight and individually tested for leaks.
- C. Valves shall be manufactured by Ford, Muller, or approved alternative.

2.06 SERVICE SADDLE

- A. Outlet threads shall meet AWWA C800.
- B. Shell shall be 304 stainless steel.
- C. Gasket shall be made of NSF 61 certified nitrile butadiene rubber.
- D. Service saddle shall be Romac Style 304, or preapproved alternate.

2.07 TAPPING SLEEVE

- A. Tapping sleeves shall be stainless steel with removable bolts and 360-degree gasket.
- B. Tapping sleeves shall meet AWWA C223 requirements.
- C. Tapping sleeves shall be Muller H-304, Ford FTSS, Romac SST, or approved alternate.

2.08 RESILIENT - SEATED GATE VALVES

- A. Resilient-Seated Gate Valves shall be iron body, Resilient-Wedge design rated for 250 psi working pressure, non-rising stem turning clockwise to open. Valves shall meet the requirements of AWWA C-515. The wedge shall be of ductile iron encapsulated with EPDM rubber and shall seal in either direction of flow.

- B. Valves shall be furnished with standard operating nut for yard installations and operating hand wheel for all interior installations unless otherwise specifically noted. Valves shall operate smoothly through the entire lift and shall have an unobstructed waterway with a diameter not less than a full nominal diameter of the valve.
- B. Valve boxes shall be standard design cast-iron with cover. Boxes shall have an outside diameter of not less than 4 inches with a minimum thickness of metal at any point of not less than 0.1875 inches. Boxes shall be set in a concrete pad of minimum dimensions 18" x 18" x 6" with 4, #4 bars at fourteen (14") inches long each centered in the pad.
- C. All Resilient-Seated Gate Valves shall be mechanical joint type for yard installations and flanged joint type for all interior installations unless otherwise specifically noted.
- D. Gate valves for two (2") inch and smaller water service shall be iron body, bronze trim, non-rising stem, with operating nut for underground installations and hand-wheel operated for above ground installation.

2.09 AIR RELEASE VALVES

- A. Air Valves shall be ARI Model S-050-C (1") or Model D-04C (2") with reinforced nylon body with a protective ductile iron shell and shall be furnished and installed as shown in the Typical Details. These valves will be field located by the Owner's Representative during construction.

2.10 STEEL AND RUBBER COUPLINGS

- A. Steel couplings, where shown on the Drawings, shall be Dresser or Smith Blair, steel couplings for the particular pipe material, or equal.
- B. See 2.01-A(4) above for protection of steel couplings.

2.11 RUBBER EXPANSION JOINT/COUPLINGS

- A. Where shown on the Drawings, these shall be suitable for the service pressure in the line where used and for normal temperatures. Rubber expansion joints shall be supplied complete with steel retaining rings and shall be drilled for coupling to the pipe flanges they are used with. Rubber expansion joints shall be standard single arch joints and shall be filled arch type when used for wastewater service.

2.12 FIRE HYDRANT

- A. Fire hydrant shall meet the requirements of AWWA C502 and shall be designed for 150 PSI working pressure. Valve opening shall be 5-1/4 inches.
- B. Hydrant shall be equipped with two 2-1/2 inch nozzles, with National Standard threads and one (1) 4 1/2 inch brass pumper nozzle with National Standard Fire Hose coupling screw threads together with caps fastened securely to each hydrant and threaded to fit nozzles.

- C. Hydrants shall have a safety "breakaway flange" section located above ground line. The distance from the finished ground line of the hydrant to the "breakaway flange" shall be not less than 2-inches or more than 6-inches.
- D. The waterways of hydrants shall be as free as possible of obstructions, sharp turns, corners, or other causes for resistance. The hydrant shall have a six (6") inch mechanical joint shoe.
- E. The hydrant main valve shall be of the compression type, closing with pressure. The valve shall be faced with heavy impregnated waterproof ballast or other approved material. The hydrant shall be "dry head type" and shall be equipped with harnessing lugs.
- F. After installation, exposed surfaces of hydrants shall be painted with two (2) coats of chrome enamel in a color as specified by the Owner to represent the flow available from the hydrant. Paint selection shall be approved by the Engineer.
- G. The hydrant operating and outlet nozzle cap nuts shall be pentagonal in shape. The pentagon shall measure 1-1/2 inches from point to flat at the base of the nut and 1-7/16 inches at the top. Nut faces shall taper uniformly, and the height of the nut shall be not less than 1-inch.
- H. The hydrant shall be opened by turning the operating nut counterclockwise. A clearly visible arrow and the word "open" shall be cast in relief on the top of the hydrant to designate the direction of opening.
- I. In the interest of standardization fire hydrants shall be "AWWA Improved Type" hydrant as manufactured by Mueller Company, Centurion, (American-Darling B-84-8 and M&H Fire Hydrant No. 129 equals are acceptable) except as outlined in "K" below.
- J. Fire Hydrants shall be U.L. listed and Factory Mutual approved.
- K. Fire Hydrants shall match existing hydrants and shall meet the approval of the governing Utility. The Engineer will assist the Contractor by furnishing information and coordinating approval.

2.14 SERVICE METERS

- A. Owner to supply new meter yokes and boxes, contractor responsible for fittings needed for connection. Solid copper only under asphalt, no joints or couplings except for connection to corporation stops.

2.15 DEAD END CAPS

- A. Dead end cap systems for connecting existing mains, flushing, and testing shall be rated for 350 psi. Usage of temporary caps must be planned ahead in order to install the proper number of restraining gaskets. See Mechanical Thrust Restraint Table in the contract drawings.

2.16 SUPPORTS, ANCHORS AND SEALS

- A. Supports, anchors and seals shall be furnished and installed in accordance with the plans.

2.17 CONCRETE MATERIALS

- A. Class A in accordance with Section 03300.

2.18 DISMANTLING JOINTS

- A. Dismantling joints shall be manufactured of ASTM A536 ductile iron meeting or exceeding Grade 65-45-12.
- B. The flanged spool shall be AWWA Class D Ring Flange compatible with ANSI Class 125 and 150 bolt circles. Pipe shall be standard weight class per ASTM A53.
- C. MJ gaskets shall be SBR compounded per AWWA C111 and flange gaskets shall be NBR, both in accordance with ASTM D2000.
- D. Bolts and nuts shall be Type 304 SST.
- E. Pressure rating shall be equal to the pressure rating of the flange.
- F. Joint shall be coated with fusion bonded epoxy, NSF certified.

2.19 COPPER PIPE AND TUBING

- A. Copper pipe shall be Type K, hard drawn (buried service) or Type L, soft drawn (interior applications). Copper tubing shall conform to ASTM B88 for seamless copper water tube with copper or brass fittings unless otherwise called for on the drawings.

2.20 SINGLE ACTING ALTITUDE VALVE

- A. VALVE DESIGN
 1. Altitude valve manufacturer shall have an ISO-9001 quality management system certified by an accredited body.
 2. The main valve shall be pilot controlled, hydraulically operated, differential piston actuated and full ported.
 3. The control valve shall be “self-contained” and incorporate a system of pilot controls, factory assembled to and tested with the main valve. The valve shall be operated by line pressure and utilize the pilot system to open, close or throttle the differential piston main valve to perform the specified function(s).
 4. Valve shall be capable of differential level (delayed opening) operation (valve will remain open until tank level drops below a preset level).

B. CONSTRUCTION

1. The main valve body shall be globe style, constructed of high-strength cast iron conforming to ASTM A126 Class B with integral flanges, faced and drilled per ANSI B16.1 Class 125.
2. The valve shall be “full-ported” so that when fully open the flow area through the valve is no less than the area of its nominal pipe size. Valve shall have an integral bottom pad or feet to permit support directly beneath the body.
3. The main valve shall operate on the differential piston principle such that the area on the underside of the piston is no less than the pipe area and the area on the upper surface is greater than that of the underside. There shall be no diaphragms or springs in the main valve.
4. The valve piston shall be fully guided on its outside diameter and all guiding and sealing surfaces shall be lead-free bronze. To minimize the consequences of throttling, throttling shall be by long, stationary vee-ports located downstream of the seat and not by the seat itself. Sawtooth attachments or other add-on devices are not permitted.
5. The valve shall be fully capable of operating in any position without the need of springs and shall not incorporate stems, stem guides or spokes in the waterway. A visual position indicator and NEMA 6P SPDT limit switch shall be provided.
6. The main valve shall be serviceable in the line through a single flanged top cover that provides easy access to all internal components.
7. The valve shall be shop coated with NSF-61 certified epoxy on internal surfaces in accordance with American Water Works Association Standard C550 (latest revision).

C. PILOT SYSTEM

1. The valve shall be operated by a system of pilot controls necessary to perform the specified function(s).
2. The pilot system shall be factory pre-piped, installed on the main valve and tested as an assembly.
3. The system shall incorporate a wye-strainer and opening and/or closing speed control valves.
4. Sufficient isolating valves and pipe unions shall be provided to facilitate removal and maintenance of the pilot system without disturbing the main valve.
5. Pilots, controls, piping and fittings shall be lead-free bronze, brass, or copper.

- D. MANUFACTURER
 - 1. Control valve shall be GA Industries differential piston design as manufactured by VAG USA, LLC.
 - 2. Alternate valve manufacturers will be considered by the Owner if submitted a minimum of 2 weeks prior to the Bid date. The Owner's decision relative to alternate valves will be final.

2.21 PRE-CAST STRUCTURES

- A. ASTM C-478 and ASTM C-913.
- B. The manufacturer shall be certified by the National Pre-cast Concrete Association's Plant Certification Program prior to and during the production of products for this project.
- C. Openings shall be provided for the required number and size of pipes and shall be marked to ensure installation at proper locations. Openings shall be placed in such a manner to all adjustments through 20 degrees.
- D. All pre-cast sections shall include non-penetrating lift inserts with locking feature for safe handling.
- E. Flexible Joint Sealants shall be butyl rubber based conforming to Federal Specification SS-S-210A, AASHTO M-198, Type B - Butyl Rubber and as follows: maximum of 1% volatile matter and suitable for application temperatures between 10 and 100 degrees F. Material shall be RV-30 as manufactured by RuVan Inc. (or approved equal) with a minimum cross section 1¼ inches.
- F. Epoxy Gels for interior patching of wall penetrations when used as approved by the Engineer shall be a 2-component, solvent-free, moisture-insensitive, high modulus, high-strength, structural epoxy paste adhesive meeting ASTM C-881, Type I and II, Grade 3, Class B and C, Epoxy Resin Adhesive.
- G. Precast Component Fabrication and Manufacture shall be as described in the following paragraph:
 - 1. Precast Manufacturing shall be in conformance with ASTM C478. Wall and inside slab finishes resulting from casting against forms standard for the industry shall be acceptable. Exterior slab surfaces shall have a float finish. Small surface holes, normal color variations, normal form joint marks, and minor depressions, chips and spalls will be tolerated. Dimensional tolerances shall be those set forth in the appropriate References and specified below.
 - 2. Joint Surfaces between Bases, Risers and Cones shall be manufactured to the joint surface design and tolerance requirements of ASTM C361 or AWWA C302. The maximum slope of the vertical surface shall be 2 degrees. The maximum annular space at the base of the joint shall be 0.10". The minimum height of the joint shall be four (4") inch.

3. Lift Inserts and Holes shall be sized for a precision fit with the lift devices, shall comply with OSHA 1926.704, and shall not penetrate through the manhole wall.
 4. Step Holes: Step holes shall be cast or drilled in the Bases, Risers and cones to provide a uniform step spacing of sixteen (16") inch. Cast step holes shall be tapered to match the taper of the steps.
 5. Where manholes and other precast sections are to be lined (interior), the following materials are pre-approved:
 - a. AQUATAPOXY Coating "A-6" as manufactured by American Chemical Corporation.
 - b. QR-304 as manufactured by QUADDEX, Inc.
 - c. Color to be white or other manufacturer's standard colors, to be selected by the Owner.
- G. Pre-cast Base Sections shall be cast monolithically without construction joints with integral floor and benching. Inverts shall be smooth and contoured for positive flow with a minimum of 1/10 foot fall between influent and effluent openings. The bottom step shall be a maximum of twenty-six (26") inches from the top of the base slab. The width of the base extensions on Extended Base Manholes shall be no less than the base slab thickness.
- H. Precast Riser Sections shall have a minimum lay length of sixteen (16") inches.
- I. Precast Concentric and Eccentric Cone Sections shall be a minimum of twenty-four (24") inches in height and shall have an inside diameter at the top of twenty-six (26") inches. The width of the top ledge shall be no less than the thickness required for the cone section. Concentric cones shall be used only for Shallow Manholes.
- J. Precast Transition Cone Sections shall provide an eccentric transition from sixty (60") inch and larger manholes to forty-eight (48") inch diameter risers, cones and flat slab top sections. The minimum slope angle for the cone wall shall be 45 degrees.
- K. Precast Transition Top Sections shall provide an eccentric transition from sixty (60") inch and larger manholes to forty-eight (48") inch diameter risers, cones and flat slab top sections. Transition Top sections shall be furnished with vents as shown on the manhole details. The maximum amount of fill over the transition top section shall be twenty (20') feet. Transition Tops shall not be used in areas subject to vehicle traffic.
- L. Precast Flat Slab Top Sections shall have a minimum thickness of six (6") inches (8" for 60" diameter and larger manholes) and shall have an inside diameter at the top of twenty-six (26") inches. They shall be designed for HS-20 traffic loadings as defined in ASTM C890. Items to be cast into Special Flat Slab Tops shall be sized to fit within the manhole ID and the top and bottom surfaces.
- M. Precast Grade Rings shall be used to adjust ring and covers to finished grade. No more than 10 vertical inches of grade rings will be allowed per manhole. Grade Rings shall conform to ASTM C478 and shall be no less than four (4") inches in

height, and twenty-four (24") inches internal diameter.

- N. Precast Inverts shall meet the following requirements.
1. Pipe openings shall provide clearance for pipe projecting a minimum of two (2") inches inside the manhole. The height of the transition from the pipe opening to the invert trough shall be equal to $\frac{1}{2}$ of the Opening ID minus Pipe ID, plus or minus $\frac{1}{4}$ ". The crown of small I.D. pipe shall be no lower than the crown of the outlet pipe. When the fall between the inlet and the outlet holes is greater than four (4") inches, the inlet end of the trough shall be below the inlet pipe invert and aligned horizontally within one (1") inch.
 2. Invert Troughs shall be formed and finished to provide a consistent slope from the pipe outlet to the inlets up to four (4") inch tall. The minimum fall shall be one-tenth (1/10') foot. A one-half inch ($\frac{1}{2}$ ") radius shall be provided at the intersection of 2 or more channels. The minimum concrete thickness from the bottom of the trough to the bottom of the base shall be seven (7") inches.
 3. Invert Benches shall have a float finish with a uniform slope. A $\frac{1}{4}$ " radius shall be provided at the edge of the bench and trough.
 4. Depressions, high spots, voids, chips, or fractured over $\frac{1}{4}$ inch in diameter or depth shall be filled with a sand cement paste and finished to a texture reasonably consistent with that of the formed surface.
- O. Precast Components and grade rings shall be sealed around the external perimeter as follows:
1. External Seals shall consist of a polyethylene backed flat butyl rubber sheet no less than 1/16" thick and 6" wide applied to the outside perimeter of the joint. Material to be RV-40-PW (or approved equal) as manufactured by RuVan, Inc.
 2. Internal Seals shall consist of plastic backed butyl rubber rope no less than 14 feet long and having a cross-sectional area no less than the annular space times the height of the joint. Double mastic joints are the only mastic joint acceptable.
- P. Lifting devices for handling Pre-cast Components shall be provided by the Pre-cast Manufacturer and shall comply with OSHA Standard 1926.704.

2.22 MANHOLE STEPS

- A. Steps shall be provided in Bases, Risers, Cones, Transition Cones, and Transition Top sections aligned vertically on sixteen (16") inch centers in accordance with ASTM C478. Steps shall be secured to the wall with a compression fit in tapered holes or cast in place. Steps shall not be vibrated or driven into freshly cast concrete or grouted in place.
- B. The steps shall be Copolymer Polypropylene Plastic reinforced with a $\frac{1}{2}$ " diameter grade 60 bar and have serrated tread and tall end lugs with red side reflectors equal to Lane International P-10938. Steps shall be capable of supporting 300 lbs. live

load at any point, and step pullout strength shall be 2000 lbs. minimum when tested according to ASTM C497.

- C. Holes for steps must be mortared smooth following placement of the steps.

2.23 PIPE ENTRANCE COUPLINGS FOR STRUCTURES

- A. Pipe to Structure Connectors shall conform to ASTM C923, and to ASTM C-425. The location of the pipe connectors shall vary from the location shown on the Project Plans no more than 1/4 inch vertically and 5 degrees horizontally. Provide for control of the OD to within the tolerances of the connector on flexible pipes larger than twelve (12") inches.
- B. Rigid cement or synthetic type grouts are not acceptable as a seal between the manhole and entry pipe.
- C. The entrance coupling with the entry pipe shall be fitted with a Neoprene Boot insert, "KOR-N-SEAL", PSX, or approved equal.
- D. Other specially designed flexible products may be approved for use in adding a pipe entrance to an installed manhole and for other uses where available and where materials meet the requirements of ASTM C-923.
- E. Internal and external bands shall be Type 302 or 304 stainless steel meeting the requirements of ASTM C923.

2.24 PRE-CAST SECTION MARKINGS

- A. All sections shall be marked with the manufacturer name and date manufactured on the inside.
- B. All sections shall be marked with the project name, manhole designation (Letter/Number), size, specification, and product designation (MH,VV,WW,GW,MV) on the outside.

PART 3 – EXECUTION

3.01 PREPARATION

- A. Install barriers and other devices to protect areas adjacent to construction.
- B. Protect and maintain all benchmarks and other survey points.
- C. Protect and maintain all pipe and equipment not scheduled for replacement, and/or all pipe and equipment scheduled for operation during the construction period of the new components.
- D. Prior to laying pipe, prepare a suitable bedding according to Section 02221.
- E. Before placing pipe in the trench, field inspect for cracks or other defect; remove

defective pipe from the construction site.

- F. Swab the interior of the pipe to remove all undesirable material.
- G. Prepare the bell end and remove undesirable material from the gasket and gasket recess.
- H. Establish line and grade for pipe and appurtenances. Verify location and elevation of other utilities and manholes for gravity sewers.

3.02 INSTALLATION

- A. Trenching and backfill shall meet the requirements of Section 02221.
- B. During pipe installation, Contractor shall take every precaution to prevent foreign material from entering the pipe or fittings. The contractor shall place a heavy, tightly woven canvas bag over each end of joint of pipe before lowering it into the trench.
- C. Jointing procedures, including cleaning of ends of pipe, and lubrication shall be in accordance with the manufacturer's recommendations. Pipe shall be laid with the bells pointing in the direction of laying.
- D. Field cutting of pipe shall be done according to the manufacturer's recommendations. Cut end shall be smooth and at right angles to the axis of the pipe. Field cuts shall be filed or trimmed to resemble the spigot end of the pipe as manufactured. Depth marks shall be placed on the pipe to assure pipe is inserted to the full depth when joint is made.
- E. Thrust blocking shall be provided at all bends (of 11-1/4 degrees or greater) and tees and valves. Blocking shall be poured against undisturbed earth, be a minimum of twelve (12") inches thick and constructed so that the pipe and fitting joints will be accessible for repairs. Install as shown in the Typical Details.
- F. All valves shall be installed plumb and true in a workmanlike manner.

3.03 PLACING DETECTION TAPE OR WIRE

- A. All buried, non-metallic water and sewer pipes shall be identified by buried detection tape or wire.
- B. Tape shall be placed directly over the pipe between one foot and three feet below finished grade and at least one foot above the top of the pipe.
- C. A different color tape shall be used for each pipe carrying a different substance.
- D. Detection wire shall be placed just below or beside pipe. Wire shall be stubbed out of valve box a minimum of 6 inches.

3.04 FIELD TESTS

- A. All newly laid water lines shall be tested before being placed in service. Trenches may be backfilled as the pipe is laid, or where practicable and at the option of the Contractor, trenches or bell holes may be left open for visual inspection during tests. Prior to making tests, all air shall be expelled from the pipe. Contractor shall install taps at high points of the line for purpose of expelling air.
- B. Pressure Test: A two (2) hour test shall be made in accordance with AWWA C600 for DIP and AWWA C605 for PVC on the pipe line between valves or temporary plugs at a test pressure of at least 1.5 times the working pressure, but not less than 150 psi, for DIP and 1.25 times the working pressure for PVC except that the pressure rating of the pipe shall not be exceeded. Any open trench or bell holes over dry joints may be backfilled following this test. Where trenches have been backfilled prior to making the tests, any leaks evident at the surface shall be uncovered. All leaking joints disclosed by this test shall be remade and retested. All pipe, fittings, valves, and other materials found defective under this test shall be removed and replaced at the Contractor's expense.
- C. Leakage Test: A leakage test shall be made on the water line concurrent with the pressure test between valves or temporary plugs at a constant test pressure as specified in "B" above. The test shall be run in accordance with AWWA C600. Leakage in the test system shall be measured through a meter or approved measuring device. The allowable leakage shall determined by the following formula:

$$L=(SD\sqrt{P})/148000$$

L= Allowable leakage in gallons/hour

S= Length of pipe section tested in feet

D= Pipe diameter in inches

\sqrt{P} = Square root of test pressure in p.s.i.

Should tests disclose leakage greater than the allowable amounts, the Contractor, at his expense, shall locate and repair defective joints until the leakage is within the specified tolerance.

3.05 DISINFECTING WATER LINES

- A. Disinfection of the completed lines shall be done in accordance with AWWA C651 and in a manner approved by the Tennessee Department of Environment and Conservation and, the Caryville-Jacksboro Utilities Commission.
- B. Prior to chlorination, the main shall be flushed as thoroughly as possible with the water pressure and outlets available. Flushing shall be done after the pressure tests are made. After flushing, all valves shall be carefully inspected to see that the entire operating mechanism is in good condition.

- C. Following disinfection, all treated water shall be thoroughly flushed from the newly laid pipeline at its extremities until the replacement water throughout its length shall, upon test, be proved comparable to the quality of water served the public from the existing water supply system and approved by the Tennessee Department of Environment and Conservation. This quality of water delivered by the new main should continue for a period of at least two full days as demonstrated by laboratory examination of samples taken from a tap located and installed in such a way as to prevent outside contamination. Samples shall not be taken from an unsterilized hose or from a fire hydrant.
- D. Should the initial treatment fail to result in the condition specified in the preceding paragraph, the disinfection procedure shall be repeated until such results are obtained. The Contractor is responsible and shall obtain the approval of the Owner for the work performed under this section.
- E. Contractor shall submit a plan to treat/contain super chlorinated water flushed from new water main, branch, service etc. to prevent nearby stream contamination.

END OF SECTION



1	4/2024	REVISED PER ADDENDUM NO. 1	REVISION DESCRIPTION
1	REV	DATE	DESCRIPTION

GENERAL NOTES:

- THE CONTRACTOR SHALL CONTACT THE TENNESSEE ONE-CALL CENTER AT 1-800-351-1111 PRIOR TO DIGGING.
- THE CONTRACTOR SHALL LOCATE AND PROTECT ALL UTILITIES.
- LOCATIONS OF EXISTING UTILITY FACILITIES, PUBLIC AND/OR PRIVATE, SHOWN ON THE PLANS ARE APPROXIMATE AND FOR GENERAL INFORMATION PURPOSES ONLY. SOME EXISTING UTILITY FACILITIES MAY NOT BE SHOWN ON THE PLANS. CONTRACTOR SHALL BE RESPONSIBLE FOR LOCATING AND VERIFYING THE LOCATIONS OF ALL EXISTING UTILITIES PRIOR TO COMMENCING CONSTRUCTION. ANY POTENTIAL CONFLICTS SHALL BE REPORTED TO THE ENGINEER IMMEDIATELY.
- THESE PLANS ARE BASED ON INFORMATION PROVIDED BY THE CARYVILLE-JACKSBORO UTILITIES COMMISSION AND SURVEY MEASUREMENTS COLLECTED IN THE FIELD. ANY DISCREPANCIES BETWEEN THE PLAN LOCATIONS AND THE ACTUAL FIELD LOCATIONS SHALL BE IMMEDIATELY COMMUNICATED TO THE DESIGN ENGINEER OR PROJECT MANAGER.
- THE EXISTING SITE FEATURES AS SHOWN OR INDICATED ON THE DRAWINGS ARE FOR GENERAL INFORMATION ONLY.
- LOCATION OF EXISTING RIGHT-OF-WAY (R.O.W.) LINES AND PROPERTY LINES SHOWN ON THESE DRAWINGS ARE APPROXIMATE AND BASED ON PROPERTY INFORMATION FROM THE CAMPBELL COUNTY PROPERTY ASSESSOR'S OFFICE.
- CONTRACTOR SHALL VERIFY WORK IN THE FIELD AND SHALL SATISFY HIMSELF AS TO THE ACCURACY BETWEEN WORK SET FORTH ON THESE PLANS AND THE WORK REQUIRED IN THE FIELD. ANY DISCREPANCIES SHALL BE BROUGHT TO THE ATTENTION OF THE PROJECT MANAGER PRIOR TO THE START OF CONSTRUCTION.
- TOPOGRAPHIC INFORMATION GENERALLY SHOWN IS FROM COLLECTED SURVEY MEASUREMENTS. CONTRACTOR TO FIELD VERIFY THESE ELEVATIONS AND SHALL SATISFY HIMSELF AS TO THE ACCURACY BETWEEN THE WORK SET FORTH ON THESE PLANS AND THE WORK REQUIRED IN THE FIELD. ANY DISCREPANCIES SHALL BE BROUGHT TO THE ATTENTION OF THE ENGINEER AT THE START OF CONSTRUCTION.
- GAS LINES, WATER LINES, AND OTHER UTILITIES SHOWN FOR GENERAL INFORMATION PURPOSES. VERIFY LOCATION PRIOR TO WORK TO PREVENT DAMAGE. ALL COSTS ASSOCIATED WITH POT-HOLING OR LOCATING EXISTING UTILITIES SHALL BE THE RESPONSIBILITY OF THE CONTRACTOR AND NO ADDITIONAL COMPENSATION WILL BE MADE BY CARYVILLE-JACKSBORO UTILITIES COMMISSION FOR THESE TASKS.
- SURVEY MONUMENTS DISTURBED BY THE CONTRACTOR SHALL BE RESET AS DIRECTED BY THE ENGINEER. PRIOR TO DISTURBANCE, CONTACT THE ENGINEER TO LOCATE AND TIE DOWN MONUMENTS.
- EXISTING UTILITY SERVICE LINES, METERS, ETC. DAMAGED DURING CONSTRUCTION ARE TO BE REPAIRED OR REPLACED IN ACCORDANCE WITH THE GOVERNING UTILITY REQUIREMENTS AT THE EXPENSE OF THE CONTRACTOR.
- THE CONTRACTOR SHALL BE RESPONSIBLE FOR ANY DAMAGE TO THE PROJECT SITE RESULTING FROM THE CONTRACTOR'S CONSTRUCTION ACTIVITIES. REPAIR ALL DISTURBED AREAS TO EQUAL OR BETTER CONDITION THAN ORIGINAL.
- THE CONTRACTOR SHALL MAINTAIN VEHICULAR AND PEDESTRIAN ACCESS TO RESIDENTS AND BUSINESSES THROUGHOUT CONSTRUCTION.
- THE CONTRACTOR SHALL PROVIDE ACCESS TO UTILITY COMPANIES FOR MAINTENANCE AND WORK ON THEIR UTILITIES DURING THE COURSE OF WORK.
- ALL CONSTRUCTION PERMITS ARE THE RESPONSIBILITY OF THE CONTRACTOR AND MAY INCLUDE, BUT ARE NOT LIMITED TO, TRAFFIC CONTROL, EXCAVATION, HAZARDOUS MATERIALS, ETC.
- THE CONTRACTOR IS RESPONSIBLE FOR THE APPLICATION, PURCHASING, OBTAINING, COMPLYING WITH, AND RENEWAL OF ALL CONSTRUCTION PERMITS.
- THE CONTRACTOR IS RESPONSIBLE FOR OBTAINING ANY ADDITIONAL LAND DEEMED NECESSARY FOR A LAY DOWN AREA, STAGING AREA, OR PERFORMANCE OF THE WORK.
- CONTRACTOR SHALL BE SOLELY AND COMPLETELY RESPONSIBLE FOR WORKING CONDITIONS ON THE JOB SITE, INCLUDING SAFETY OF ALL PERSONS AND PROPERTY DURING PERFORMANCE OF WORK. THIS REQUIREMENT SHALL APPLY CONTINUOUSLY AND NOT BE LIMITED TO NORMAL WORKING HOURS.
- TRENCH DESIGN AND SAFETY FOR PIPELINE CONSTRUCTION IS SOLELY THE RESPONSIBILITY OF THE CONTRACTOR AND SHALL CONFORM TO ALL APPLICABLE LOCAL, STATE, AND OSHA REGULATIONS.
- THE CONTRACTOR SHALL ENSURE POSITIVE DRAINAGE TO AND THROUGH EXISTING DRAINAGE FACILITIES WHERE IMPACTED BY THE WORK.
- WHEN EXCAVATION MUST OCCUR NEAR A UTILITY POLE, THE CONTRACTOR SHALL NOTIFY AND OBTAIN APPROVAL AND/OR DIRECTION FROM LAFOLETTE UTILITIES BOARD (LUB) PRIOR TO EXCAVATION.
- WHEN EXCAVATION MUST OCCUR NEAR A UTILITY POLE, THE CONTRACTOR SHALL EMPLOY A LICENSED ELECTRICAL CONTRACTOR TO GUY, ANCHOR, BRACE, MECHANICALLY HOLD, ETC. THE POLE THROUGHOUT THE EXCAVATION PROCESS AND UNTIL THE AREA CAN BE PROPERLY BACKFILLED AND COMPACTED TO PREVENT THE MOVEMENT OF THE POLE. IF THE EXCAVATION AFFECTS AN ANCHOR, THE POLE WILL NEED TO BE STABILIZED IN A SIMILAR MANNER UNTIL THE ANCHOR CAN BE REINSTALLED IN THE EXACT LOCATION. CONTRACTOR SHALL NOTIFY LUB NOT LESS THAN SEVEN (7) CALENDAR DAYS PRIOR TO EXCAVATION WITHIN TWENTY (20) FEET OF ANY POLE AND SHALL PROVIDE INFORMATION TO LUB PERTAINING TO THE METHOD THAT IS TO BE USED TO STABILIZE THE POLE, AS WELL AS THE NAME OF THE ELECTRICAL CONTRACTOR RESPONSIBLE FOR THE PORTION OF WORK.
- THE CONTRACTOR SHALL MAINTAIN TRAFFIC CONTROL AND PROVIDE ADEQUATE WARNING SIGNS AND TEMPORARY TRAFFIC CONTROL DEVICES IN ACCORDANCE WITH LOCAL REQUIREMENTS AND THE LATEST EDITION OF THE MANUAL ON UNIFORM TRAFFIC CONTROL DEVICES (MUTCD). THE CONTRACTOR SHALL FURNISH, INSTALL, AND MAINTAIN ADVANCE WARNING SIGNS AND TEMPORARY TRAFFIC CONTROL SIGNS AND MARKING AS REQUIRED BY THE MUTCD THROUGHOUT CONSTRUCTION. CONTRACTOR SHALL SUBMIT A TRAFFIC CONTROL PLAN IN ACCORDANCE WITH LOCAL REQUIREMENTS, AND THE LATEST EDITION OF THE MUTCD PRIOR TO ANY CONSTRUCTION ACTIVITIES FOR OWNER APPROVAL.
- ASPHALT AND OTHER CONSTRUCTION DEBRIS SHALL BE REMOVED OFFSITE BY THE CONTRACTOR AND DISPOSED OF IN ACCORDANCE WITH ALL APPLICABLE REGULATIONS.
- WHERE EXISTING PAVEMENT IS CUT, IT SHALL BE SAW CUT IN A NEAT STRAIGHT LINE THROUGH PAVEMENT AND BASE.
- ASPHALT PAVEMENT INSTALLATION AND REPAIRS SHALL BE IN ACCORDANCE WITH THE DETAILS UNLESS OTHERWISE NOTED HEREIN OR IN THE PROJECT SPECIFICATION DOCUMENTS.

EROSION AND SEDIMENT CONTROL NOTES:

- ALL SEDIMENT AND EROSION CONTROLS AND STRUCTURES TO BE IN PLACE BEFORE CONSTRUCTION BEGINS.
- OWNER: CARYVILLE-JACKSBORO UTILITIES COMMISSION, 585 MAIN STREET, JACKSBORO, TN 37757 APPROXIMATE TOTAL DISTURBED AREA: < 1 ACRES.
- EROSION AND SEDIMENT CONTROL SHALL BE THE CONTRACTOR'S RESPONSIBILITY FOR COMPLIANCE, INSTALLATION, MAINTENANCE AND REMOVAL AS REQUIRED BY THE TENNESSEE DEPARTMENT OF ENVIRONMENT AND CONSERVATION (TDEC) "EROSION AND SEDIMENT CONTROL HANDBOOK", LATEST EDITION AS PUBLISHED BY TDEC. THE CONTRACTOR SHALL BECOME FAMILIAR WITH THESE SPECIFICATIONS PRIOR TO ANY CONSTRUCTION ACTIVITIES. THE INSTALLATION OF THE REQUIRED EROSION AND SEDIMENT CONTROL MEASURES SHALL BE INSTALLED AS A FIRST STEP IN THE SEQUENCE OF CONSTRUCTION.
- THE LOCATION OF SOME EROSION CONTROL DEVICES MAY BE FIELD ADJUSTED OR ALTERED FROM THAT SHOWN ON THE PLANS.
- MANDATORY MAINTENANCE AND HOUSEKEEPING OF SITE CONDITIONS, MATERIALS, AND EQUIPMENT SHALL BE OBSERVED EACH WORKING DAY AS TO NOT CREATE RISKS TO OTHERS SAFETY AND ENVIRONMENT.
- EROSION CONTROL MEASURES WILL BE MAINTAINED AT ALL TIMES. IF FULL IMPLEMENTATION OF APPROVED PLAN DOES NOT PROVIDE FOR EFFECTIVE EROSION CONTROL, ADDITIONAL EROSION AND SEDIMENT CONTROL MEASURES SHALL BE IMPLEMENTED TO CONTROL OR TREAT THE SEDIMENT SOURCE.
- SILT FENCE SHALL BE INSTALLED AS REQUIRED TO PREVENT SEDIMENT FROM THIS PROJECT BEING DEPOSITED ON ANY ADJACENT PROPERTY OR INTO ADJACENT DRAINAGE PATHS.
- EROSION AND SEDIMENT CONTROL DEVICES SHALL BE REGULARLY INSPECTED BY THE CONTRACTOR. THE CONTRACTOR SHALL BE RESPONSIBLE FOR THE REPAIR AND OR REMOVAL OF ACCUMULATED SILTS AND SEDIMENT FROM THE EROSION AND SEDIMENT CONTROL DEVICES. THE CONTRACTOR SHALL BE RESPONSIBLE FOR ALL MAINTENANCE OF SAID STRUCTURES, ETC. ALL SILTS AND/OR SEDIMENTS REMOVED FROM THE EROSION/SEDIMENT CONTROL DEVICES SHALL BE DEPOSITED ONSITE IN SUCH A MANNER AS TO PREVENT SAID SILTS AND/OR SEDIMENT FROM REENTERING THE CONTROL DEVICES AND/OR EXITING THE SITE THROUGH THE STORM DRAINAGE SYSTEMS AND/OR SURFACE DRAINAGE.
- CONSTRUCTION ENTRANCES TO BE A MINIMUM 6" DEPTH T.D.O.T. NO. 1 OR NO. 2 STONE.
- CONTRACTOR SHALL PREVENT EROSION OF DISTURBED AREAS INTO ADJACENT STREAMS/DITCHES/STORM SEWER BY USING APPROPRIATE EROSION CONTROL DEVICES.
- INSTALL SILT FENCE ALONG CONTOURS AND AS SHOWN ON THE PLANS.
- INSTALL INLET PROTECTION DEVICES AT STORM SEWER INLETS PRIOR TO CONSTRUCTION.
- WHERE APPROPRIATE, WATTLES, SEDIMENT TUBES, ETC. MAY BE USED IN LIEU OF SILT FENCING WITH APPROVAL FROM THE OWNER OR ENGINEER.
- DISTURBED AREAS TO BE CONTAINED WITH APPROPRIATE SEDIMENT AND EROSION CONTROL DEVICES TO PREVENT MIGRATION OF SEDIMENT OFF SITE, INTO WATERWAYS, OR INTO THE LOCAL STORMWATER SYSTEM. IF EXCAVATED OR DISTURBED AREA CANNOT BE STABILIZED WITH PERMANENT OR TEMPORARY MEASURES (INCLUDING PAVEMENT) AS PRACTICAL OR BEFORE A RAIN EVENT, ADDITIONAL SEDIMENT AND EROSION CONTROL MEASURES MAY BE NECESSARY.
- WATER MAINS AND EXCAVATED AREAS SHALL BE BACKFILLED AND STABILIZED WITHIN THE SAME WORKING DAY AND BEFORE A RAIN EVENT. OTHERWISE, THE WORKING AREA SHALL HAVE APPROPRIATE SEDIMENT AND EROSION CONTROL FEATURES INSTALLED AS NECESSARY.
- AFTER COMPLETING EACH SECTION OF THE PIPE, ALL DEBRIS AND CONSTRUCTION MATERIALS SHALL BE REMOVED FROM THE WORK SITE. THE DISTURBED GROUND SURFACE SHALL BE SMOOTHLY GRADED.
- ALL GRADED SLOPES 2:1 OR STEEPER SHALL BE COVERED WITH AN EROSION CONTROL BLANKET BY NORTH AMERICAN GREEN OR OTHER APPROVED MANUFACTURER. BLANKET SHALL BE DESIGNED FOR THE SLOPE CONDITIONS AND INSTALLED IN ACCORDANCE WITH THE MANUFACTURER'S RECOMMENDATION.
- RIP-RAP CHECK DAMS SHALL BE PLACED IN ALL DIVERSION DITCHES AND, AS OTHERWISE SHOWN ON THE THE PLANS.
- ALL STOCK PILE AREAS TO BE PROTECTED BY SILT FENCE OR APPROVED EQUIVALENT.

TEMPORARY SEEDING:

- AREAS TO BE TEMPORARILY STABILIZED WITH GRASS SHALL FOLLOW THESE GENERAL GUIDELINES.
- SEED MIXTURES SHALL BE APPLIED AT APPROXIMATELY 10 LBS/1,000 SQ. FT. OR PER MANUFACTURER'S RECOMMENDATION.
- SEED MIXTURE RATIOS SHALL FOLLOW RECOMMENDATIONS FOR THE APPLICABLE TIME OF YEAR AS DESCRIBED IN THE BEST MANAGEMENT PRACTICE FOR "DISTURBED AREA STABILIZATION (WITH TEMPORARY VEGETATION)," ACCORDING TO THE TENNESSEE EROSION AND SEDIMENT CONTROL HANDBOOK (CURRENT EDITION).

SITE NOTES:

- CONTRACTOR SHALL MAINTAIN ACCESS TO THE EXISTING INDUSTRIES AT ALL TIMES DURING CONSTRUCTION.
- CONTRACTOR SHALL MAINTAIN EXISTING ACCESS ROAD TO PROVIDE HOLSTON GASES PERSONNEL ACCESS TO THEIR EXISTING FACILITIES.
- AT CONCLUSION OF CONSTRUCTION, THE EXISTING GRAVEL DRIVE SHALL BE RESTORED TO PRE-CONSTRUCTION CONDITIONS.
- CONTRACTOR SHALL COORDINATE WITH THE GEOTECHNICAL ENGINEER FOR OBSERVATION, TESTING, AND RECOMMENDATIONS FOR THE TANK FOUNDATION.
- REMOVE ALL TOPSOIL AND ORGANICS FROM THE TANK SITE AND, WORKING AREA AROUND THE TANK.
- MATERIAL UTILIZED FOR STRUCTURAL FILL SHALL BE CLEAN SOIL FREE OF ORGANICS AND OTHER DELETERIOUS MATERIAL, CONTAINING NO ROCK FRAGMENTS GREATER THAN 6 INCHES IN ANY DIMENSION. STRUCTURAL SOIL FILL SHALL HAVE A STANDARD PROCTOR MAXIMUM DRY DENSITY OF 90 PCF OR GREATER AND A PLASTICITY INDEX OF 35 PERCENT OR LESS. ON-SITE MATERIALS MAY BE UTILIZED IF APPROVED BY THE GEOTECHNICAL ENGINEER.
- PLACE STRUCTURAL FILL IN LOOSE HORIZONTAL LIFTS NOT EXCEEDING 8 INCHES IN THICKNESS. COMPACT EACH LIFT TO 98% OF THE SOIL'S STANDARD PROCTOR MAXIMUM DRY DENSITY PER ASTM D698 WITHIN -2% TO +3% OF OPTIMUM MOISTURE CONTENT. EACH LIFT SHALL BE TESTED BY THE GEOTECHNICAL ENGINEER.
- DENSE GRADED AGGREGATE (TYPE A, GRADING D OR E PER TDOT 903.05) MAY BE USED AS BACKFILL IN THE UNDERCUT AREAS. THE DGA SHALL BE PLACED IN 8 INCH LOOSE LIFTS AND COMPACTED TO 98% MAXIMUM DRY DENSITY. EACH LIFT SHALL BE TESTED BY THE GEOTECHNICAL ENGINEER.
- THE TANK SUBGRADE SHALL NOT BE ALLOWED TO DRY OR GET EXCESSIVELY WET DURING CONSTRUCTION.

PIPING NOTES:

- CONNECTION TO THE EXISTING WATER MAINS SHALL BE MADE UNDER THE SUPERVISION OF THE OWNER'S REPRESENTATIVE.
- COORDINATE THE CONNECTION LOCATIONS WITH THE OWNER'S REPRESENTATIVE. EXCAVATE THE EXISTING PIPING AND PROVIDE A PLAN FOR PIPE CONNECTIONS FOR APPROVAL PRIOR TO ORDERING MATERIALS OR COMMENCING WORK.
- ALL BURIED FITTINGS SHALL BE RESTRAINED WITH MECHANICAL RESTRAINTS BY MEGALUG OR SIGMA. ALL PIPING SHALL BE PROPERLY RESTRAINED BY RESTRAINING GASKETS OR JOINT RESTRAINTERS ADJACENT TO BENDS ACCORDING TO THE TYPICAL DETAILS.
- THE OVERFLOW DISCHARGE VALVE SHALL BE TIDFLEX SERIES 35-1, ANSI B16.10, CLASS 150# FLANGED, EPDM CONSTRUCTION, WITH STAINLESS STEEL BACKUP RINGS OR, ENGINEER APPROVED ALTERNATE.
- ALL WATER MAINS TO BE BEDDED AND BACKFILLED WITH MATERIALS WITH NO ROCK FRAGMENTS IN EXCESS OF 1" IN ANY DIMENSION. CLEAN SOIL OR AGGREGATE MEETING THE ABOVE REQUIREMENT ARE ACCEPTABLE FOR USE AS BEDDING AND INITIAL BACKFILL.
- WATER MAINS OUTSIDE THE TANK SITE SHALL BE ATSM D2441, SDR17 PVC.
- THE OVERFLOW, TANK VENT, AND TANK DRAIN SCREENS SHALL BE 24-MESH 316SS. OVERFLOW AND DRAIN SCREENS SHALL BE INSTALLED BETWEEN 2 PIPE FLANGES.



LEGEND:

<p>EXISTING PROPERTY LINE</p> <p>EXISTING ADJACENT PROPERTY LINE</p> <p>EXISTING RIGHT-OF-WAY</p> <p>EXISTING EASEMENT</p> <p>EXISTING INDEX CONTOUR</p> <p>EXISTING INTERMEDIATE CONTOUR</p> <p>EXISTING FENCE</p> <p>EXISTING CHAIN LINK FENCE</p> <p>EXISTING IRON FENCE</p> <p>EXISTING WOOD FENCE</p> <p>EXISTING DITCH FLOW LINE</p> <p>EXISTING SANITARY SEWER LINE</p> <p>EXISTING SANITARY FORCE MAIN LINE</p> <p>EXISTING COMBINED SEWER LINE</p> <p>EXISTING STORM SEWER LINE</p> <p>EXISTING GAS LINE</p> <p>EXISTING WATER LINE</p> <p>EXISTING FIBER OPTIC LINE</p> <p>EXISTING TELEPHONE LINE</p> <p>EXISTING UNDERGROUND ELEC. LINE</p> <p>EXISTING OVERHEAD ELECTRIC</p> <p>EXISTING TREE LINE</p> <p>EXISTING BUSHES</p> <p>EXISTING SPOT ELEVATION</p>	<p>NEW PROPERTY LINE</p> <p>NEW RIGHT-OF-WAY</p> <p>NEW EASEMENT</p> <p>NEW INDEX CONTOUR</p> <p>NEW INTERMEDIATE CONTOUR</p> <p>NEW FENCE</p> <p>NEW DITCH FLOW LINE</p> <p>NEW SANITARY SEWER LINE</p> <p>NEW SANITARY SEWER LINE</p> <p>NEW STORM SEWER LINE</p> <p>NEW GAS LINE</p> <p>NEW WATER LINE</p> <p>NEW FIBER OPTIC LINE</p> <p>NEW TELEPHONE LINE</p> <p>NEW UNDERGROUND ELEC. LINE</p> <p>NEW OVERHEAD ELECTRIC</p> <p>NEW SPOT ELEVATION</p>	<p>TRAVERSE POINT</p> <p>IRON PIN FOUND</p> <p>RAILROAD SPIKE FOUND</p> <p>MAG / PK NAIL FOUND</p> <p>CHISELED MARK FOUND</p> <p>CONCRETE MONUMENT FOUND</p> <p>R/W MONUMENT FOUND</p> <p>STONE FOUND</p> <p>FENCE POST FOUND</p> <p>DRILL HOLE FOUND</p> <p>AERIAL CONTROL POINT</p> <p>GPS STATION</p> <p>BENCHMARK</p> <p>IRON PIPE FD. (SIZE)</p> <p>STATE MONUMENT</p> <p>REBAR FD. (SIZE)</p> <p>NAIL FOUND</p> <p>WOOD STAKE/HUB</p> <p>ANGLE IRON</p> <p>AXLE</p> <p>LEAD PLUG</p> <p>SECTION CORNER MON.</p> <p>MAG NAIL SET</p> <p>REBAR IRON PIN SET & CAP</p> <p>CUT "X" SET</p> <p>CONCRETE MONUMENT SET</p> <p>PERMANENT MARKER (SIZE)</p>	<p>MAILBOX</p> <p>FLAG POLE</p> <p>GROUND LIGHT</p> <p>SIGN</p> <p>SATELLITE DISH</p> <p>LIGHT STANDARD</p> <p>AC UNIT</p> <p>BOLLARD</p> <p>PARKING METER</p> <p>ANTENNA</p> <p>GRAVE</p> <p>HANDICAP PARKING SYMBOL</p> <p>TEST PIT</p> <p>MONITORING WELL @ TOP OF COVER</p> <p>SOIL SAMPLE</p> <p>TEST SITE</p> <p>STORM MANHOLE</p> <p>CATCH BASIN (TYPE)</p> <p>CURB INLET</p> <p>RISER PIPE</p> <p>INLET (CIRCULAR)</p> <p>DRAIN</p> <p>BEEHIVE INLET SQUARE</p> <p>INLET SQUARE</p> <p>RECESSED CURB INLET</p>	<p>SAN UTILITIES</p> <p>CLEAN OUT</p> <p>COMBINATION MANHOLE</p> <p>STAND PIPE (RISER)</p> <p>LIFT STATION</p> <p>WATER MANHOLE</p> <p>WATER BOX (WATER VALVE)</p> <p>FIRE HYDRANT</p> <p>WATER WELL</p> <p>SPRINKLER VALVE</p> <p>WATERLINE MARKER</p> <p>WATER METER</p> <p>WATER PUMP</p> <p>HOSE BIB BUILDING</p> <p>PIV - POST INDICATOR VALVE</p> <p>SPRINKLER HEAD</p> <p>IRRIGATION VALVE</p> <p>IRRIGATION CONTROL BOX</p> <p>FIRE DEPT. CONNECTION</p> <p>FIRE DEPT. CONNECTION (BLDG.)</p> <p>FARM SPIGOT</p>	<p>SANITARY MANHOLE</p> <p>CLEAN OUT</p> <p>COMBINATION MANHOLE</p> <p>GAS METER</p> <p>STAND PIPE (RISER)</p> <p>LIFT STATION</p> <p>WATER MANHOLE</p> <p>WATER BOX (WATER VALVE)</p> <p>FIRE HYDRANT</p> <p>WATER WELL</p> <p>SPRINKLER VALVE</p> <p>WATERLINE MARKER</p> <p>WATER METER</p> <p>WATER PUMP</p> <p>HOSE BIB BUILDING</p> <p>PIV - POST INDICATOR VALVE</p> <p>SPRINKLER HEAD</p> <p>IRRIGATION VALVE</p> <p>IRRIGATION CONTROL BOX</p> <p>FIRE DEPT. CONNECTION</p> <p>FIRE DEPT. CONNECTION (BLDG.)</p> <p>FARM SPIGOT</p>	<p>GAS UTILITIES</p> <p>GAS MANHOLE</p> <p>GAS LINE MARKER</p> <p>GAS BOX (GAS VALVE)</p> <p>GAS METER</p> <p>GAS TAP</p> <p>PROPANE TANK</p> <p>GAS WELL</p> <p>TREE, DECIDUOUS (800 SIZE TYPE)</p> <p>TREE, CONIFER (800 SIZE TYPE)</p> <p>BUSH/SHRUB (SIZE)</p> <p>STUMP</p> <p>POWER POLE</p> <p>GUY WIRE</p> <p>GUY POLE</p> <p>FIBER OPTIC POLE</p> <p>TELEPHONE PEDESTAL</p> <p>TELEPHONE LINE MARKER</p> <p>TELEPHONE MANHOLE</p> <p>ELECTRIC MANHOLE</p> <p>ELECTRIC LINE MARKER</p> <p>ELECTRIC PULL BOX (FLUSH WITH GRADE)</p> <p>ELECTRIC CONTROL BOX (ON BUILDING)</p> <p>HIGH TENSION TOWER</p> <p>ELECTRIC METER</p> <p>FIBER OPTIC MARKER</p> <p>TRAFFIC POLE</p> <p>TRAFFIC MANHOLE</p>	<p>VEGETATION</p> <p>TREE, DECIDUOUS (800 SIZE TYPE)</p> <p>TREE, CONIFER (800 SIZE TYPE)</p> <p>BUSH/SHRUB (SIZE)</p> <p>STUMP</p> <p>POWER POLE</p> <p>GUY WIRE</p> <p>GUY POLE</p> <p>FIBER OPTIC POLE</p> <p>TELEPHONE PEDESTAL</p> <p>TELEPHONE LINE MARKER</p> <p>TELEPHONE MANHOLE</p> <p>ELECTRIC MANHOLE</p> <p>ELECTRIC LINE MARKER</p> <p>ELECTRIC PULL BOX (FLUSH WITH GRADE)</p> <p>ELECTRIC CONTROL BOX (ON BUILDING)</p> <p>HIGH TENSION TOWER</p> <p>ELECTRIC METER</p> <p>FIBER OPTIC MARKER</p> <p>TRAFFIC POLE</p> <p>TRAFFIC MANHOLE</p>	<p>MISC. UTILITIES CONTROL</p> <p>CABLE PEDESTAL</p> <p>TRAFFIC SIGNAL BOX/CABINET (ABOVE GRADE)</p> <p>MANHOLE (UTILITY UNKNOWN)</p> <p>OIL WELL</p> <p>VALVE BOX (UNKNOWN, FLUSH WITH GRADE)</p> <p>TELEPHONE PULL BOX (FLUSH WITH GRADE)</p> <p>UTILITY CABINET (UNKNOWN, ABOVE GRADE)</p> <p>VAULT</p> <p>ELECTRIC HANDHOLE</p> <p>STEAM MANHOLE</p> <p>TRANSFORMER</p> <p>STAND PIPE</p> <p>TRAFFIC PULL BOX (FLUSH WITH GRADE)</p> <p>TRAFFIC DETECTOR HOUSING</p> <p>FIBER OPTIC PULL BOX (FLUSH WITH GRADE)</p> <p>UTILITY POLE</p> <p>ELECTRIC CONTROL CABINET (ABOVE GRADE)</p> <p>TELEPHONE BOX/CABINET (ABOVE GRADE)</p> <p>FIBER OPTIC BOX/CABINET (ABOVE GRADE)</p> <p>FIBER OPTIC MANHOLE</p> <p>UTILITY PULL BOX (UNKNOWN, FLUSH WITH GRADE)</p> <p>ELECTRIC PEDESTAL</p> <p>TEST BORING</p> <p>PERC HOLE</p> <p>SEEP</p>
---	--	--	--	--	--	--	--	---

CARYVILLE-JACKSBORO UTILITIES COMMISSION
CAMPBELL COUNTY, TENNESSEE
ERSHELL COLLINS INDUSTRIAL PARK WATER TANK

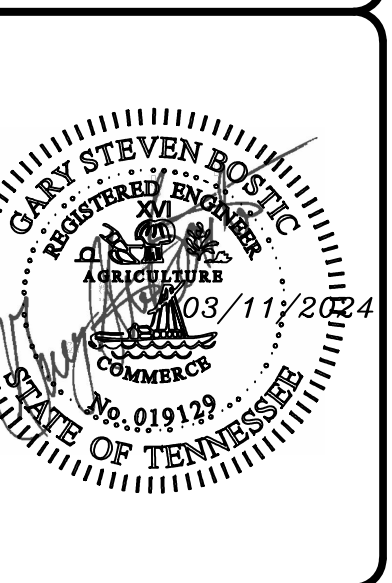

PROJECT NUMBER: CUJ05	
DATE: 03/2024	SCALE: AS SHOWN
DRAWN BY: BAS	DESIGNED BY: GSB

SHEET TITLE:
GENERAL NOTES AND LEGEND

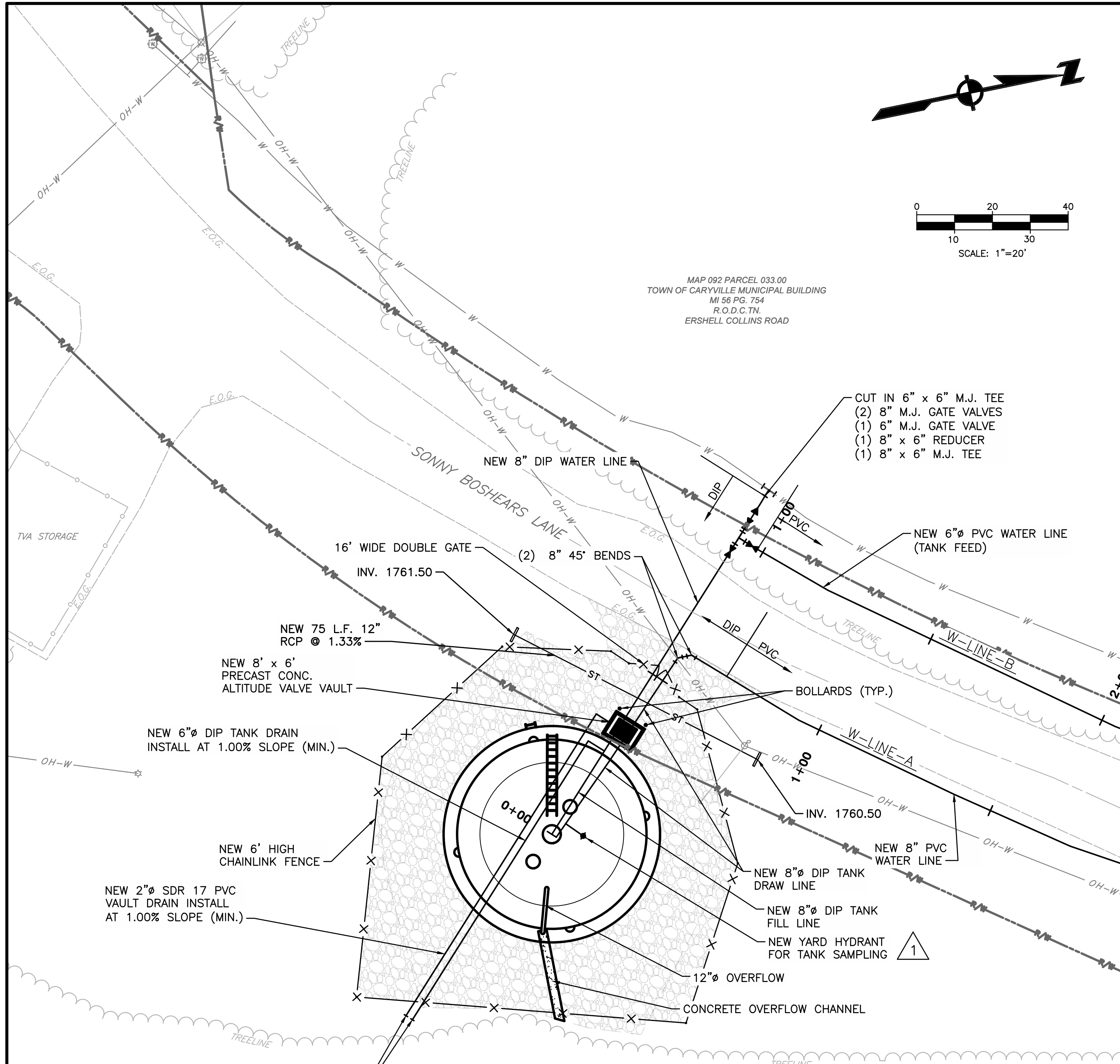

YARD PIPING PLAN
SCALE: 1"=20'

MAP 104 PARCEL 003.00
UTICA REALTY CARYVILLE, LLC.
WDB 487 PG. 314
R.O.D.C.TM
1126 LUTHER SEIBER BOULEVARD

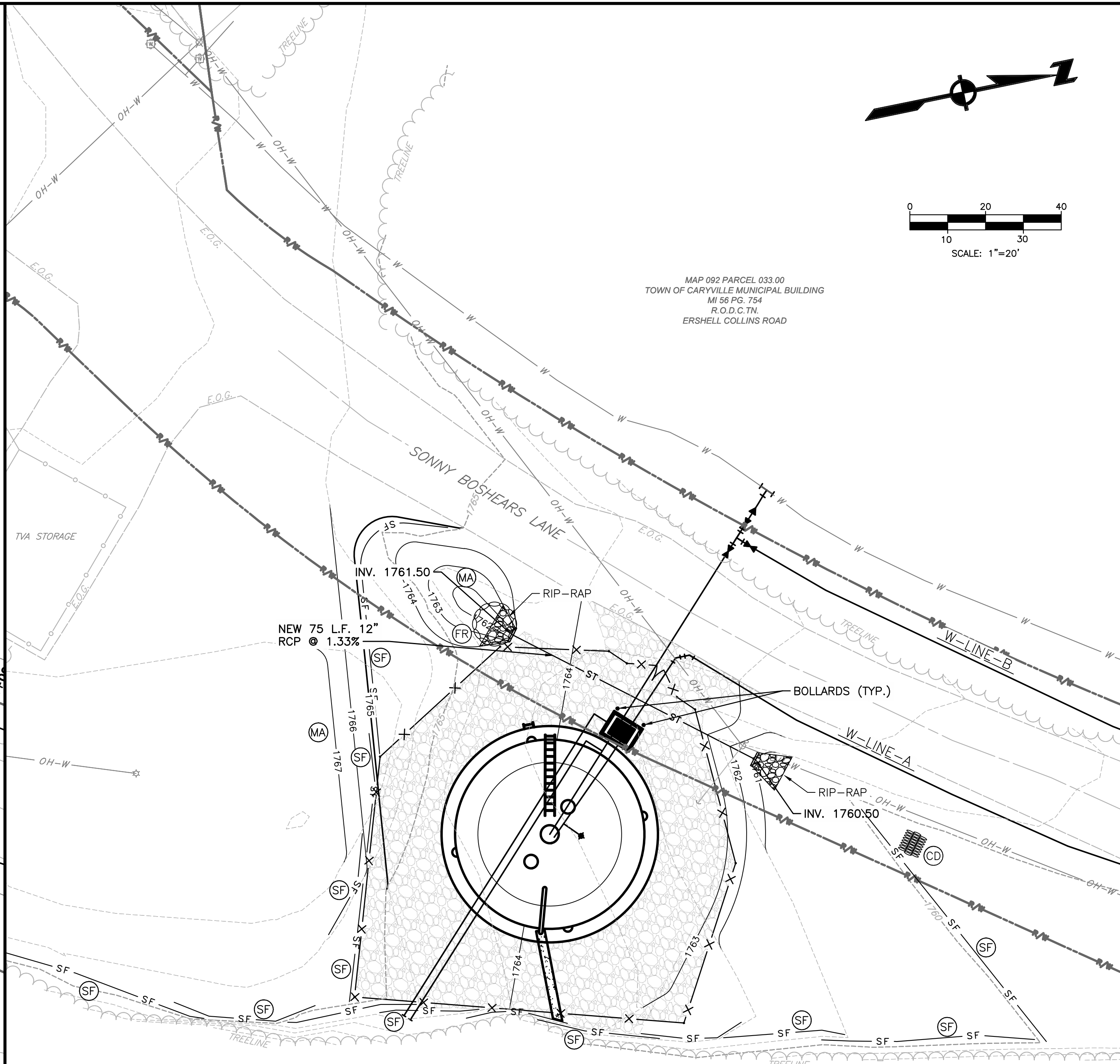

GRADING PLAN
SCALE: 1"=20'

MAP 104 PARCEL 003.00
UTICA REALTY CARYVILLE, LLC.
WDB 487 PG. 314
R.O.D.C.TM
1126 LUTHER SEIBER BOULEVARD

- LEGEND**
- NEW SILT FENCE
 - NEW EROSION CONTROL BLANKET
 - NEW CHECK DAM
 - NEW RIP-RAP FILTER RING



REV	DATE	REVISION DESCRIPTION
1	04/2024	REVISED PER ADDENDUM NO. 1

CARYVILLE-JACKSBORO UTILITIES COMMISSION
CAMPBELL COUNTY, TENNESSEE
ERSHELL COLLINS INDUSTRIAL PARK WATER TANK

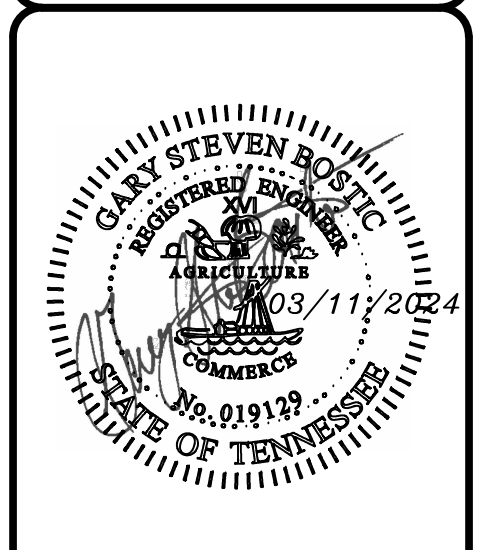

PROJECT NUMBER: CJU305
DATE: 03/2024 SCALE: 1"=20'
DRAWN BY: BAS DESIGNED BY: GSB

SHEET TITLE:
YARD PIPING PLAN &
GRADING PLAN

P:\CADD\DESIGN\SHEET FILES\CAD\03_03_2024_414_PIP_DRAWLET_SMTI

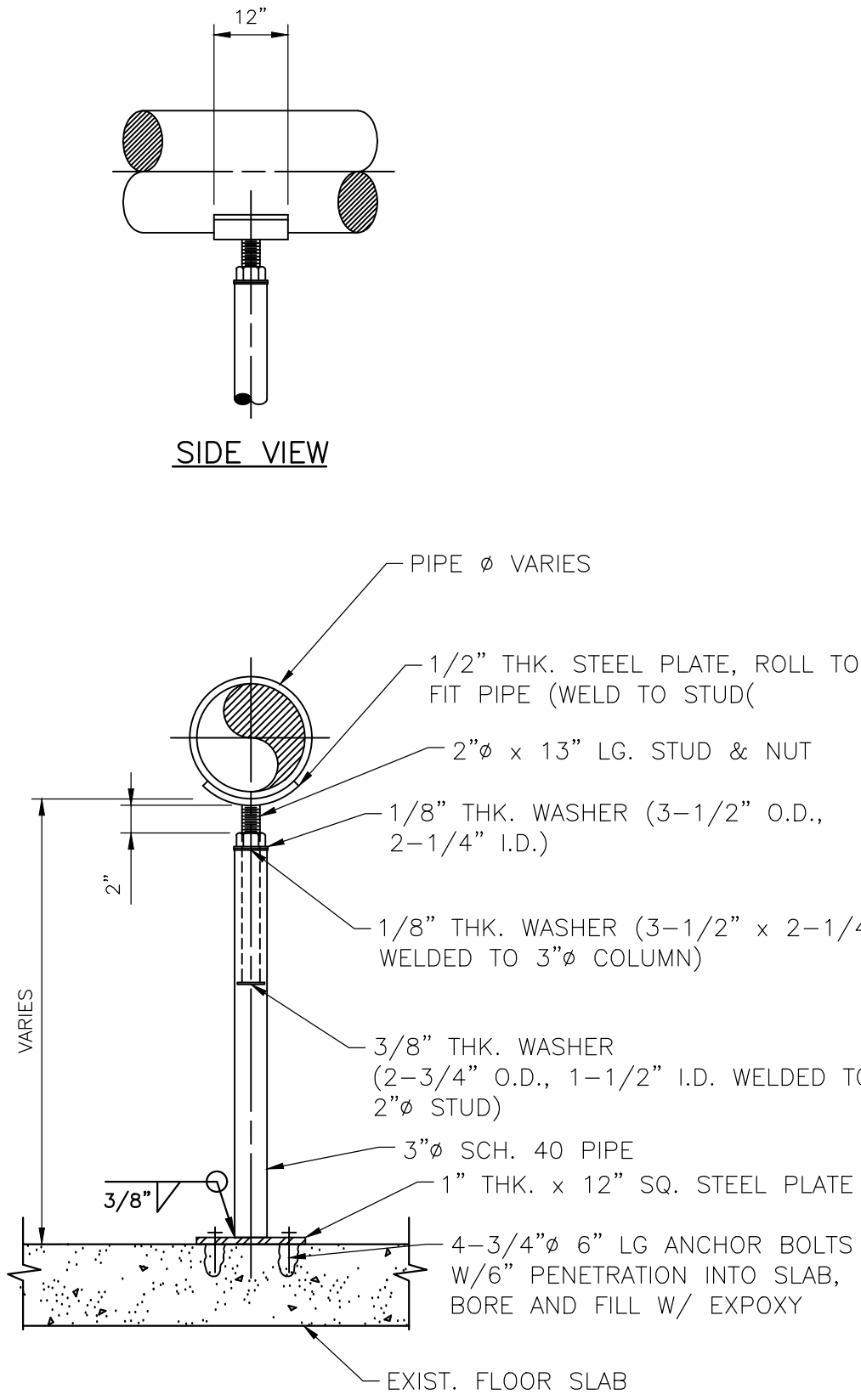

STEEL PIPE SUPPORT DETAIL

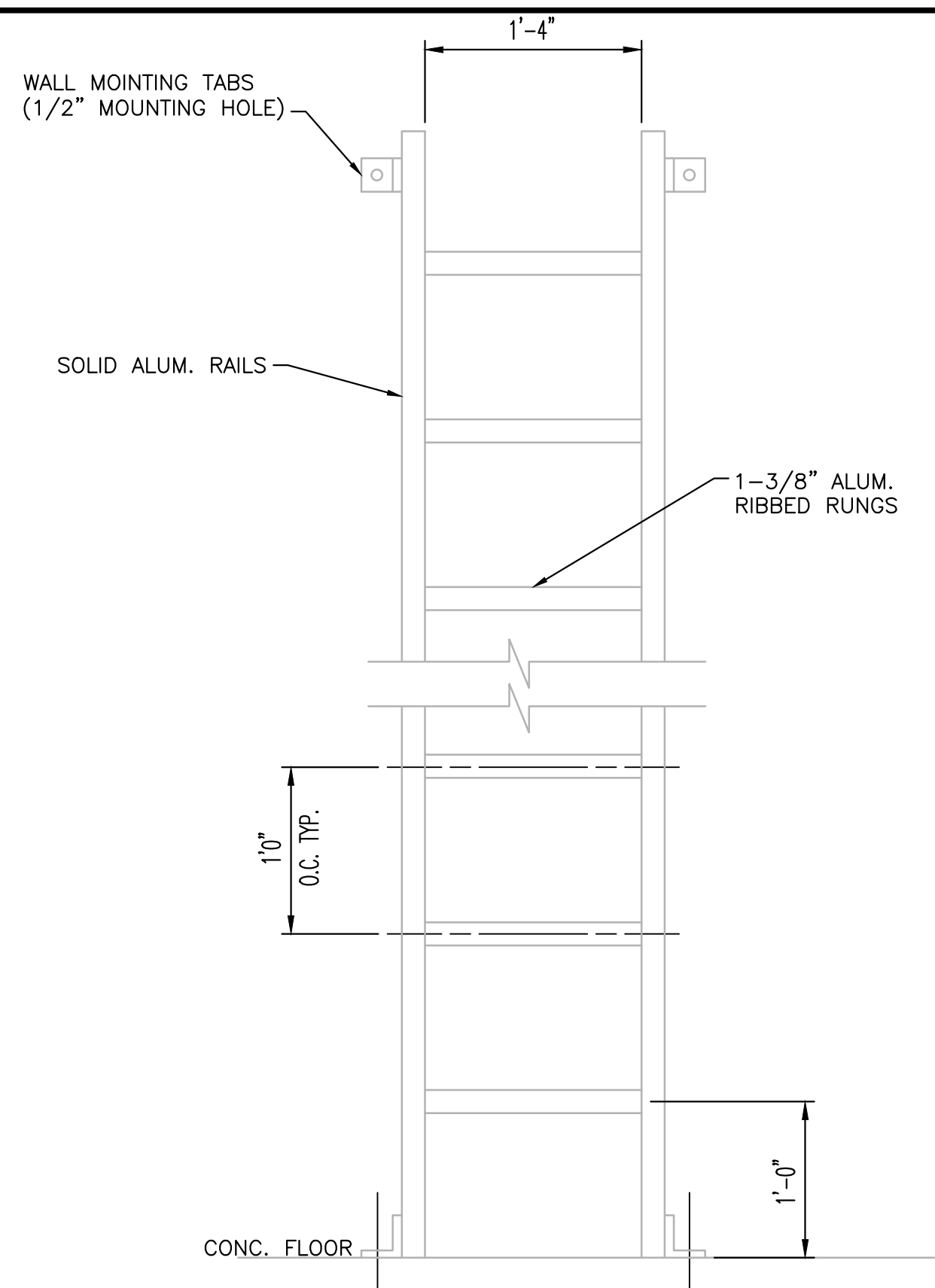

NOTES:

- LADDER TO BE HALLIDAY PRODUCTS SERIES L1D, OR APPROVED EQUAL. WALL MOUNTING TABS TO BE MOUNTED TO VAULT TOP.
- LADDER TO BE DESIGNED TO PROVIDE STABILITY WITH 2 POINT MOUNTING AS SHOWN. FOR VALVE VAULT, PROVIDE INTERMEDIATE SUPPORTS AS REQUIRED IN GINDER WELL.

LADDER DETAIL

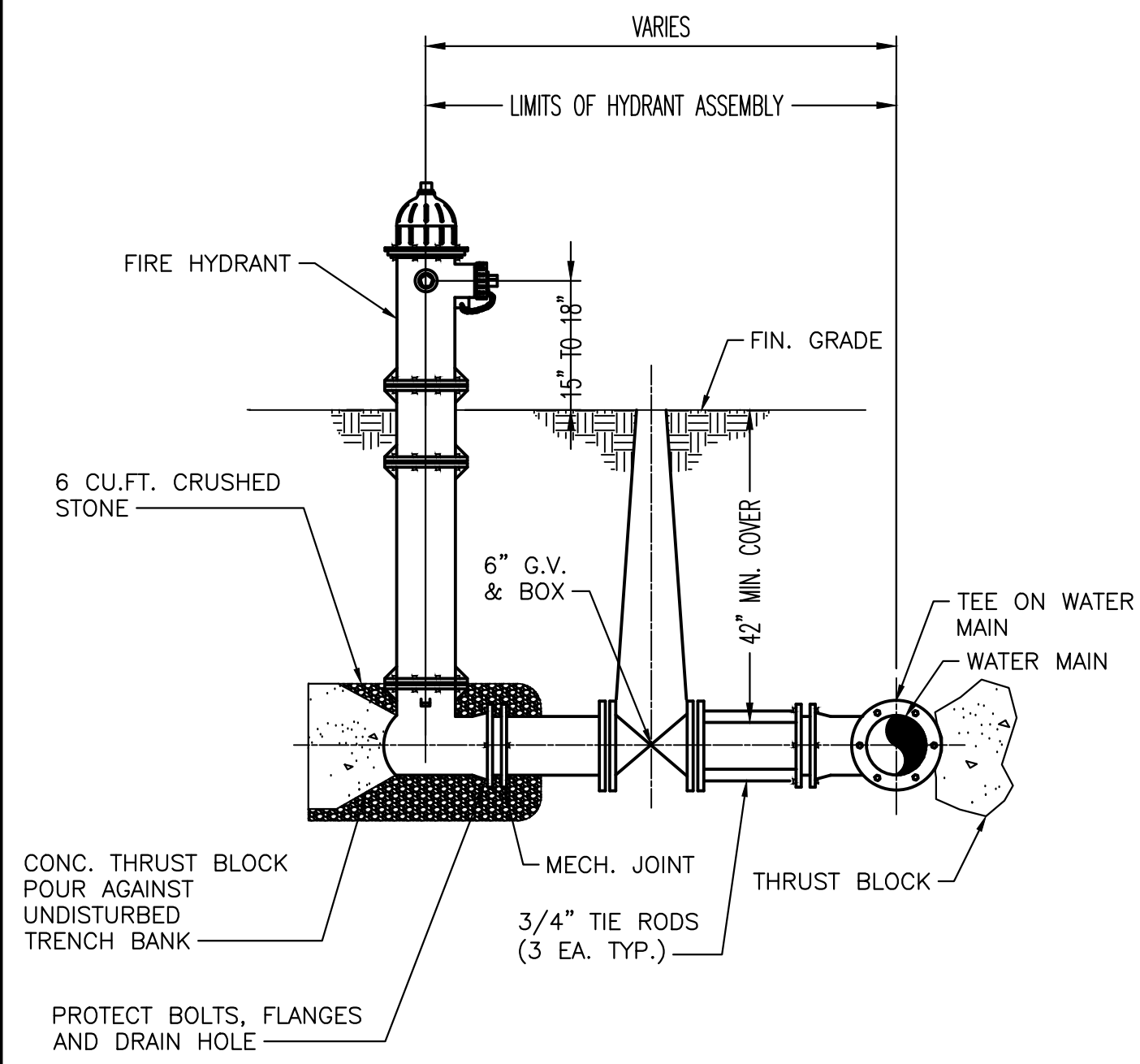

TYPICAL HYDRANT ASSEMBLY

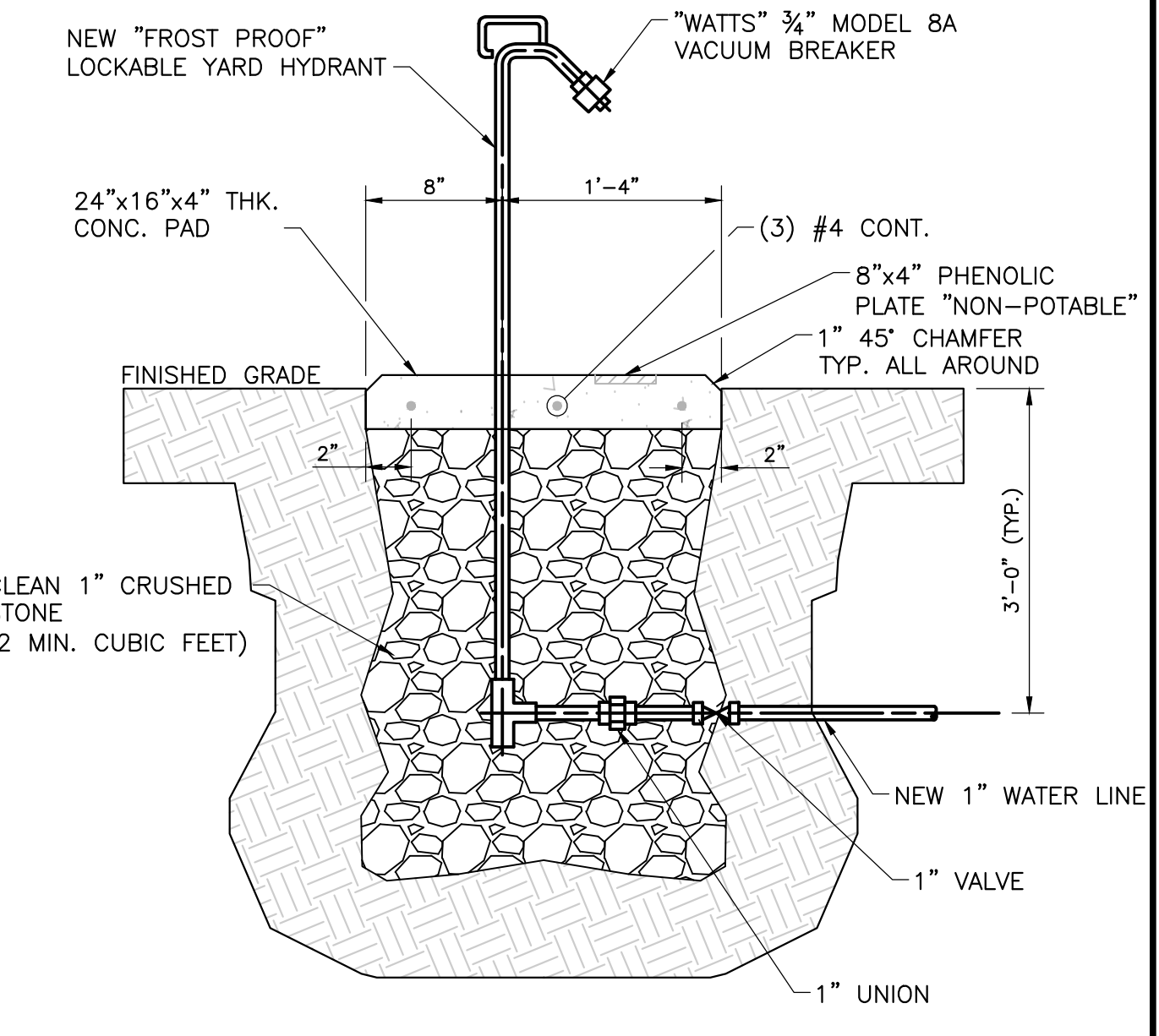

1 "FROST PROOF" YARD HYDRANT DETAIL

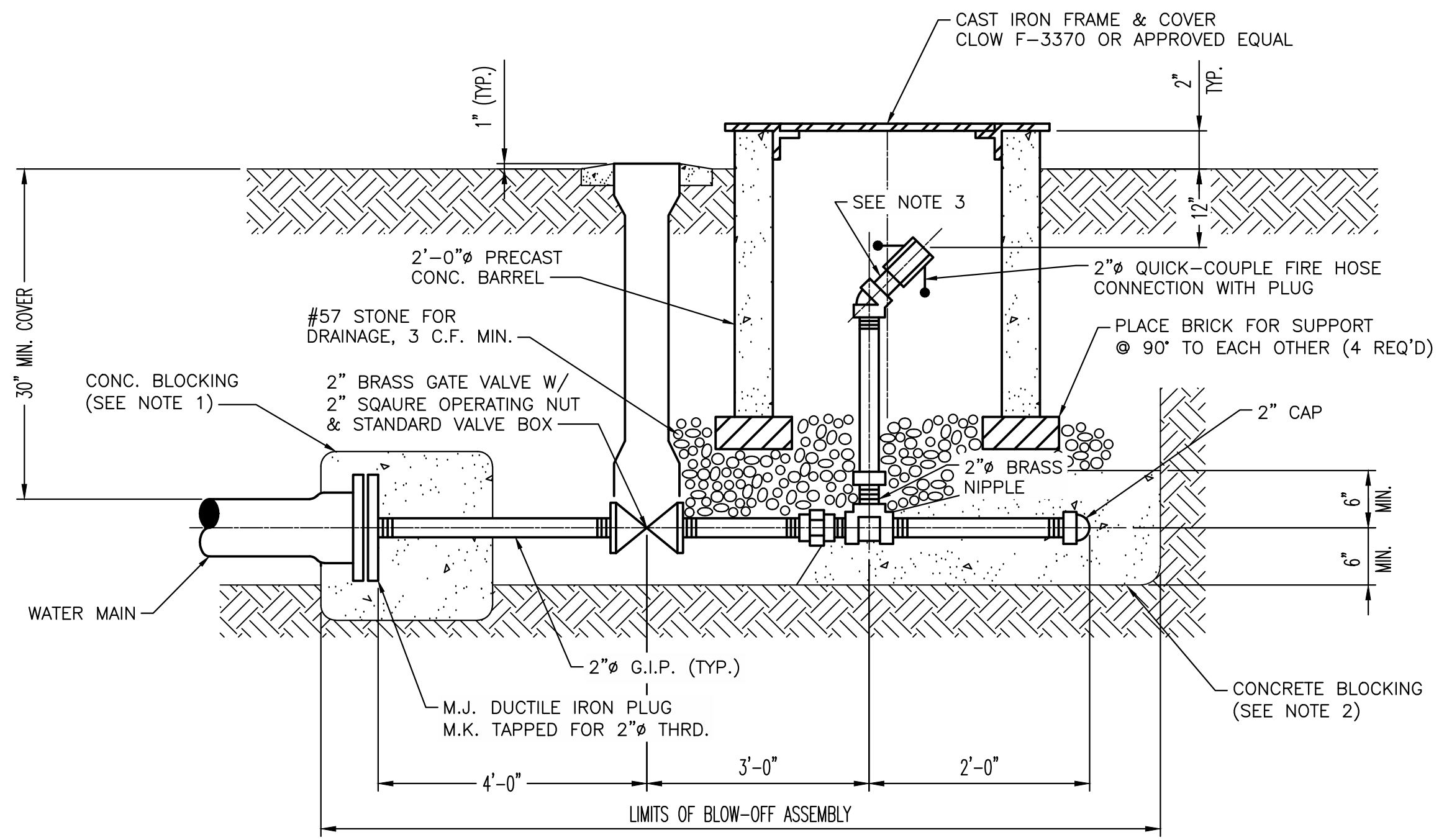

NOTES:

- CONCRETE BLOCKING AT WATER MAIN PLUG FOR BLOW-OFF PIPE CONNECTION SHALL BE A MINIMUM OF 1'-6" THICK AND BE CUT A MINIMUM OF 1'-0" INTO UNDISTURBED SOIL ON EACH SIDE AND BELOW THE PIPE TRENCH.
- CONCRETE BLOCKING BELOW "TEE" AND BEHIND PIPE CAP SHALL BE THE WIDTH OF THE TRENCH OR 1'-0" WHICHEVER IS GREATER, AND SHALL BEAR AGAINST UNDISTURBED SOIL.
- ALL THREADED PIPE SHALL BE JOINTED USING HEAVY DUTY TEFLON JOINT TAPE. ALL EXPOSED THREADS AND ALL GALVANIZED IRON PIPE SHALL BE CLEANED OF ALL GREASE, OIL, DEBRIS & OTHER SOILING AND SHALL RECEIVE A HEAVY COAT OF COAL-TAR EPOXY COATING PRIOR TO BACKFILLING.

TYPICAL BLOW OFF VALVE DETAIL



REV	DATE	REVISION DESCRIPTION
1	4/2024	REVISED PER ADDENDUM NO. 1

CARYVILLE-JACKSBORO UTILITIES COMMISSION
 CAMPBELL COUNTY, TENNESSEE
 ERSHELL COLLINS INDUSTRIAL PARK WATER TANK

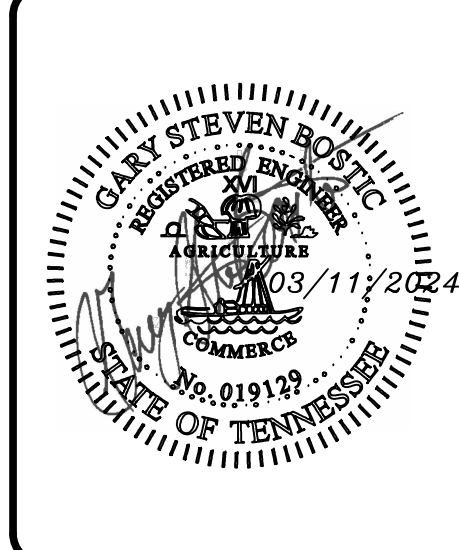

PROJECT NUMBER: CUJ305
 DATE: 03/2024 SCALE: AS SHOWN
 DRAWN BY: BAS DESIGNED BY: GSB

SHEET TITLE:
 TYPICAL DETAILS

P:\CADD\DESIGN\SHEET FILES\CAD\01_TYPICAL DETAILS.DWG, 4/10/2024 4:13 PM, GIBNEY SUMI