

# **PROJECT MANUAL**

SPECIFICATIONS AND CONTRACT DOCUMENTS

## **WATER SYSTEM IMPROVEMENTS**

FOR THE

**CITY OF DAYTON, TENNESSEE**

CONTRACT 23-01  
SUMMER CITY ROAD WATER RELOCATION

FUNDED BY ARPA GRANT NO. 2022-7863-DW-PDC-01

**PROJECT NUMBER 4657**

**MARCH 2024**

**WAUFORD**

2835 Lebanon Pike  
Nashville, Tennessee 37214  
[www.jrwauford.com](http://www.jrwauford.com)

PROJECT MANUAL

SPECIFICATIONS AND CONTRACT DOCUMENTS

WATER SYSTEM IMPROVEMENTS

FOR THE

CITY OF DAYTON, TENNESSEE

CONTRACT 23-01  
SUMMER CITY ROAD WATER RELOCATION

FUNDED BY ARPA GRANT NO. 2022-7863-DW-PDC-01

PROJECT NUMBER 4657

MARCH 2024

**WAUFORD**

2835 Lebanon Pike  
Nashville, Tennessee 37214  
[www.jrwauford.com](http://www.jrwauford.com)



OFFICIALS  
FOR  
DAYTON, TENNESSEE

MAYOR

Hurley Marsh

VICE MAYOR

Steve E. Randolph

COUNCILMEN

Bobby J. Doss  
William C. "Billy" Graham  
Caleb Yawn

CITY MANAGER

David Shinn

SUPERINTENDENT OF WATER DEPARTMENT

Marty Morgan

CITY ATTORNEY

Susan E. Arnold

TABLE OF CONTENTS  
4657 – March 2024

TABLE OF CONTENTS

Advertisement for Bids .....	AB-1 – AB-3
Instructions to Bidders .....	IB-1 – IB-10
General Conditions .....	GC-1 – GC-72
Supplementary Conditions .....	SC-1 – SC-2
SLRF Supplemental Conditions	
A Listing of the Duties, Responsibilities and Limitations of Authority of the Resident Project Representative .....	Page 1 – 4
Bid Form .....	BF 1 – 11
Bid Bond .....	BB 1 – 3
Acknowledgement Regarding Bidder SAM Registration	
Certification of Bidder Regarding Equal Employment Opportunity	
Certification of Bidder Regarding Use of Women/Minority Subcontractors	
Certification Regarding Debarment, Suspension and Other Responsibility Matters	
Certification by Proposed Subcontractor Regarding Equal Employment Opportunity	
Certification of Subcontractor Regarding Debarment, Suspension, Ineligibility and Exclusion	
Byrd Anti-Lobbying Amendment Certification	
Drug-Free Workplace Affidavit	
Statement of Compliance Certificate Illegal Immigrant	
Iran Divestment Act Certification	
Non-Boycott of Israel Certification	
Agreement .....	A 1 – 7
Performance Bond .....	PEB 1 – 2
Payment Bond .....	PAB 1 – 2

DETAILED SPECIFICATIONS

SECTION 1 – General Scope and Special Provisions

1. Scope.....	DS 1-1
2. Execution and Coordination of the Work.....	DS 1-1
3. Temporary Traffic Control Plan .....	DS 1-2
4. Time of Completion and Liquidated Damages .....	DS 1-2
5. Guarantee – One Year Warranty .....	DS 1-2
6. Engineer’s Authority .....	DS 1-2
7. Shop Drawings.....	DS 1-3
8. Initial Videos, Pictures and Progress Pictures.....	DS 1-4
9. Progress Schedule and Progress Meetings.....	DS 1-4
10. Utilities Required by Contractor .....	DS 1-4



# TABLE OF CONTENTS

4657 – March 2024

11.	Project Sign.....	DS 1-5
12.	Field Office.....	DS 1-5
13.	Existing Utilities.....	DS 1-5
14.	Permits, Codes, Agreements and/or Contracts with Private Utilities .....	DS 1-6
15.	Protection of Roadways On and Off-Site .....	DS 1-6
16.	Lands, Rights-of-Way and Limits of Work.....	DS 1-6
17.	Undesirable Workmen .....	DS 1-7
18.	Work Hours.....	DS 1-7
19.	Materials or Equipment to be Furnished .....	DS 1-7
20.	Occupational Safety and Health Act .....	DS 1-8
21.	Noise, Odor and Dust Control .....	DS 1-8
22.	Chemical Requirements.....	DS 1-8
23.	Confined Spaces.....	DS 1-8
24.	Lines and Grades.....	DS 1-9
25.	Restoration of Disturbed Areas/Work on or Adjacent to Private Property .....	DS 1-9
26.	Reference to Tennessee Department of Transportation Specifications and Standard Roadway and Structure Drawings .....	DS 1-10
27.	References to Standard General Conditions of the Construction Contract .....	DS 1-10
28.	Applicability of Governing Standards .....	DS 1-10
29.	Connecting to Existing Lines and Facilities.....	DS 1-10
30.	Subsurface Conditions/Site Conditions.....	DS 1-11
31.	Blasting .....	DS 1-11
32.	Water and Uplift .....	DS 1-11
33.	Flooding .....	DS 1-11
34.	Temporary Project Water Pollution Control (Soil Erosion) .....	DS 1-11
35.	Substantial Completion/Delays in Final Completion.....	DS 1-12
36.	Finish Grading, Topsoiling, Seeding and Sodding .....	DS 1-13
37.	Final Inspection.....	DS 1-14
38.	Disposal of Demolition Debris .....	DS 1-14
	Project Sign Example	

## SECTION 2 – Testing and Control of Materials

1.	Scope.....	DS 2-1
2.	Cost of Tests and Selection of Testing Agencies.....	DS 2-1
3.	Sources of Supply .....	DS 2-1
4.	Approval of Testing Agencies and Reports .....	DS 2-2
5.	Governing Specifications .....	DS 2-2
6.	Extent of Inspection and Testing Service .....	DS 2-2
7.	Cement .....	DS 2-3
8.	Fine Aggregate (For Use in Cement Concrete).....	DS 2-3
9.	Coarse Aggregate (For Use in Cement Concrete) .....	DS 2-3
10.	Advance Tests of Concrete Design Mix(es).....	DS 2-3

## TABLE OF CONTENTS

4657 – March 2024

11.	Reinforcing Steel.....	DS 2-3
12.	Structural Steel .....	DS 2-4
13.	Steel Bar Joists .....	DS 2-4
14.	Brick.....	DS 2-4
15.	Building Stone.....	DS 2-4
16.	Concrete Pipe .....	DS 2-4
17.	Polyvinyl Chloride (PVC) Pressure Pipe .....	DS 2-4
18.	Polyvinyl Chloride (PVC) Sewer Pipe .....	DS 2-5
19.	Ductile Iron Pipe and Special Castings.....	DS 2-5
20.	Grey Iron Castings .....	DS 2-5
21.	Polyethylene Pipe .....	DS 2-5

### SECTION 3 - Concrete and Reinforcing Steel

1.	Scope .....	DS 3-1
2.	Reference Codes and Standards.....	DS 3-1
3.	Class of Concrete .....	DS 3-2
4.	Determination of Strength of Concrete.....	DS 3-3
5.	Concrete Design Mixes .....	DS 3-3
6.	Materials for Concrete.....	DS 3-3
7.	Proportioning of Materials for Concrete .....	DS 3-5
8.	Source of Supply of Concrete .....	DS 3-6
9.	Alteration of Concrete Slump (Retempering) .....	DS 3-7
10.	Placing of Concrete.....	DS 3-8
11.	Curing of Concrete .....	DS 3-10
12.	Joints in Concrete .....	DS 3-11
13.	Non-Shrink Grout.....	DS 3-14
14.	Forms for Concrete Work.....	DS 3-14
15.	Floor Drains, Sleeves, and Inserts .....	DS 3-17
16.	Slabs on Grade .....	DS 3-17
17.	Aluminum Safety Treads.....	DS 3-19
18.	Concrete Finish.....	DS 3-20
19.	Watertightness .....	DS 3-22
20.	Defective Concrete .....	DS 3-23
21.	Testing of Concrete.....	DS 3-23
22.	Reinforcing Steel.....	DS 3-24
23.	Concrete Repair Material .....	DS 3-26

### SECTION 4 – Water Lines and Appurtenances

1.	Scope.....	DS 4-1
2.	Location of Utility Lines .....	DS 4-1
3.	Pipeline Materials for Water Lines .....	DS 4-1
4.	On-Site Inspection of Pipeline Materials .....	DS 4-6

TABLE OF CONTENTS

4657 – March 2024

5.	Alignment and Grades .....	DS 4-7
6.	Excavation for Pipeline Trenches and Appurtenances.....	DS 4-7
7.	Shoring, Sheet piling and Bracing of Excavations .....	DS 4-11
8.	Pipe Laying, Bedding and Protection – Water Lines .....	DS 4-11
9.	Unauthorized Excavation and Over-Breakage .....	DS 4-12
10.	Crushed Stone for Pipe Bedding in Rock.....	DS 4-13
11.	Highway Crossings .....	DS 4-13
12.	Backfilling Pipeline Trenches .....	DS 4-14
13.	Pipeline Trenches Within Existing Roadways .....	DS 4-16
14.	Inspection of Lines – During Construction .....	DS 4-17
15.	Hydrostatic Testing of Water Lines .....	DS 4-17
16.	Disinfection of Lines .....	DS 4-18
17.	Gate Valves and Boxes .....	DS 4-18
18.	Rip-Rap.....	DS 4-19
19.	Rock Excavation .....	DS 4-19
20.	Pipe Laying and Bedding for Water Lines .....	DS 4-19
21.	Replacing Streets and Roadways .....	DS 4-20
22.	Class “C” Concrete for Kickers, Anchors and Encasements .....	DS 4-22
23.	Final Clean-up.....	DS 4-23

SECTION 5 – Basis of Payment

1.	General .....	DS 5-1
2.	Connections to Existing Facilities.....	DS 5-1
3.	Water Line.....	DS 5-1
4.	Restrained Joint Pipe.....	DS 5-1
5.	Steel Casing Pipe .....	DS 5-2
6.	PVC Casing Pipe for Service Lines.....	DS 5-2
7.	Gate Valve Assemblies .....	DS 5-2
8.	Air Release Valves.....	DS 5-2
9.	3/4-inch Service Connections .....	DS 5-2
10.	Service Line Installation – 3/4-inch Type K Copper Service Lines.....	DS 5-2
11.	Class “C” Concrete for Kickers, Anchors and Encasement.....	DS 5-2
12.	Flowable Fill Backfill.....	DS 5-3
13.	Undercutting of Trench and Stone for Undercutting .....	DS 5-3
14.	Crushed Stone for Traffic Bound Surfacing, Base Course and Backfill.....	DS 5-3
15.	Asphaltic Concrete Pavement.....	DS 5-3
16.	Temporary Silt Fence.....	DS 5-4
17.	Rip-Rap.....	DS 5-4

\*\*\*\*\*

ADVERTISEMENT FOR BIDS  
4657 – March 2024

ADVERTISEMENT FOR BIDS  
WATER SYSTEM IMPROVEMENTS  
DAYTON, TENNESSEE  
ARPA GRANT NO. 2022-7863-DW-PDC-01

Separate sealed BIDS for the construction of Water System Improvements for the City of Dayton, Tennessee, will be received at City Hall, 399 1<sup>st</sup> Avenue, Dayton, Tennessee 37321, until 2:00 P.M. Eastern Time, Wednesday, June 26, 2024, at which time and place they will be publicly opened and read aloud. Bids being mailed for this work should be mailed to David Shinn, City Manager, City of Dayton, Tennessee, P.O. Box 226, Dayton, Tennessee 37321, and each bidder shall be responsible for their delivery by the above noted time.

The work is in one Contract and includes the following general items of work:

CONTRACT 23-01  
SUMMER CITY ROAD WATER RELOCATION

- Relocation of approximately 382 L.F. of 6-inch Water Line
- Relocation of approximately 1,725 L.F. of 4-inch Water Line
- Relocation of approximately 43 L.F. of 2-inch Water Line
- Open-cut Highway Crossings, Creek Crossing and Service Reconnections

as described in the Detailed Specifications and shown on the Plans.

The allotted time for construction for this contract is 60 calendar days. Liquidated damages are one thousand dollars (\$1,000.00) per calendar day.

The CONTRACT DOCUMENTS may be examined at the following locations:

J. R. Wauford & Company, 2835 Lebanon Pike, Nashville, TN 37214

Complete digital project bidding documents are available at [www.questcdn.com](http://www.questcdn.com) and/or [www.jrwauford.com](http://www.jrwauford.com). Bidders may download the digital plan documents for \$45.00 by inputting Quest project # 9160463 on the QuestCDN project search page. Please contact QuestCDN at 952-233-1632 or [info@questcdn.com](mailto:info@questcdn.com) for assistance in free membership registration, downloading, and working with the digital project information. Inquiries should be directed to Daniel G. Tribble, P.E., [danielt@jrwauford.com](mailto:danielt@jrwauford.com), 615-883-3243.

This project is being supported with Treasury, Coronavirus State and Local Recovery Fund grant funding; therefore, certain restrictions and other federal requirements attach to this opportunity. The City of Dayton, Tennessee hereby notifies all bidders that it will affirmatively ensure that in any contract entered into pursuant to this advertisement will be afforded full opportunity to submit bids in response to this invitation and will not be

## ADVERTISEMENT FOR BIDS

4657 – March 2024

discriminated against on the grounds of race, color, sex, or national origin in consideration for an award. The City of Dayton, Tennessee is an Equal Opportunity Employer. Any contract that uses federal funds to pay for construction work is a “federally assisted construction contract” and must include the equal opportunity clause found in 2 C.F.R. Part 200, unless otherwise stated in 41 C.F.R. Part 60. We encourage all small and minority owned firms and women’s business enterprises to participate.

The Copeland "Anti-Kickback" Act is also applicable, which prohibits workers on construction contracts from giving up wages that they are owed. Contractors must not appear on Sam.gov disbarment list.

Each bidder must deposit with his bid, security in the amount, form and subject to the conditions provided in the Instructions for Bidders.

The successful bidder is required to furnish both an acceptable performance bond and payment bond each in the amount of one hundred percent (100%) of the contract price.

All bidders must be licensed general contractors as required by the Contractor’s Licensing Act of 1976 of the General Assembly of the State of Tennessee and qualified for the type of construction being bid upon. EACH BIDDER SHALL WRITE ON THE OUTSIDE OF THE ENVELOPE CONTAINING THE BID THE CONTRACTOR’S LICENSE NUMBER, THE EXPIRATION DATE, AND THAT PART OF THE CLASSIFICATION APPLYING TO THIS BID. If this is not done, the bid will not be opened.

Each bidder shall be properly licensed and abide by the provisions of TCA 62-6-119 including part (b) which states in part:

“(b) The person or entity involved in the preparation of the invitation to bid or comparable bid documents, including any electronic bid documents, shall direct that the following information be written upon the bid envelope or provided within the electronic bid document: (1) The name, license number, expiration date thereof, and license classification of the contractor applying to bid for the prime contract; (2) The name, license number, expiration date thereof, and license classification of the contractor applying to bid for the masonry contract where the total cost of the materials and labor for the masonry portion of the construction project exceeds one hundred thousand dollars (\$100,000); (3) The name, license number, expiration date thereof, and license classification of the contractor applying to bid for the electrical, plumbing, heating, ventilation, or air conditioning contracts except when such contractor’s portion of the construction project is less than twenty-five thousand dollars (\$25,000); (4) For each vertical closed loop geothermal heating and cooling project, the company name, Tennessee Department of Environment and Conservation license number, classification (G, L or G,L) and the expiration date, except when the geothermal portion of the construction project is in an amount less than twenty-five thousand dollars (\$25,000); (5) Prime contractor bidders who are to perform the masonry portion of the construction

ADVERTISEMENT FOR BIDS

4657 – March 2024

project which exceeds one hundred thousand dollars (\$100,000), materials and labor, the electrical, plumbing, heating, ventilation or air conditioning or the geothermal heating and cooling must be so designated; and (6) Only one (1) contractor in each of the classifications listed above shall be written on the bid envelope or provided within the electronic bid document.”

In compliance with TCA 12-4-126(a) and (b) the ENGINEER will not issue addenda less than forty-eight (48) hours before the bid opening date and time; further, any questions concerning the bid documents shall be received by the ENGINEER before ninety-six (96) hours prior to the bid opening date and time.

The Owner reserves the right to reject any and all bids, to waive informalities, and to negotiate with the apparent qualified best bidder or bidders to such extent as may be necessary.

No bidder may withdraw his bid for 90 days, while the Owner considers the bids. Mutually agreed upon time extensions may be made if necessary.

Attention of bidders is particularly called to the requirements as to conditions of employment to be observed and minimum wage rates to be paid under the contract, Section 3, Segregated Facility, Section 109 and E.O. 11246.

DAYTON, TENNESSEE

/s/

---

Honorable Hurley Marsh  
Mayor

\*\*\*\*\*

INSTRUCTIONS TO BIDDERS  
October 2019

ALPHABETICAL INDEX OF  
INSTRUCTIONS TO BIDDERS  
STATE OF TENNESSEE

Award of Contract	IB - 3
Bid Guaranty	IB - 2
Certificate of Insurance	IB - 7
Commencement and Completion of Work	IB - 8
Compliance with Iran Divestment Act	IB - 10
Construction Records and Reports	IB - 8
Contract Surety; Performance and Payment Bonds	IB - 2
Discrepancy - Bid Price	IB - 2
Drug-Free Workplace Program Requirements	IB - 9
Execution of Contracts	IB - 4
Funds for Partial Payment Estimates	IB - 8
Insurance, Builders Risk	IB - 7
Insurance, Contractor's Coverage and Cancellation Provision	IB - 4
Insurance, Commercial General Liability, Automobile Liability and Excess Liability	IB - 5
Insurance, Workmen's Compensation and Employer's Liability	IB - 6
Interpretation of Contract Documents	IB - 3
Lands and Rights-of-Way	IB - 8
Laws and Regulations	IB - 9
Liquidated Damages for Failure to Enter into Contract	IB - 4
Modifications of Bids	IB - 3
Ownership of Contractor's License	IB - 9
Payment of Employees	IB - 9
Preparation and Submission of BID FORM	IB - 1
Qualifications of Bidders	IB - 2
Sanitary Facilities	IB - 8
Second Hand and Salvaged Materials	IB - 3
Statement of Compliance Certificate Illegal Immigrants	IB - 10
Subcontracts	IB - 9
Supplementary Conditions	IB - 1
Wages and Hours and Non-Discrimination	IB - 9

INSTRUCTIONS TO BIDDERS  
STATE OF TENNESSEE

1. Preparation and Submission of BID FORM

Bidders shall inform themselves fully of all conditions relating to the proposed work. Bids shall be submitted on the separate copy of the BID FORM supplied for that purpose. The BID FORM contained in the Specifications and Contract Documents is for the convenience of the Bidders and is not to be detached from the bound set of documents or filled out or executed unless a separate BID FORM is not furnished to the Bidder.

The BID FORM shall be enclosed in a sealed envelope which shall be clearly labeled with the name of the project, contract number, name, address, and contractor's license number of the Bidder, the expiration date of the Contractor's license, that part of the classification applying to this Bid, and the date and time of opening (so as to guard against premature opening of any Bid).

BID FORMS that contain any omission, conditions, or limitations, or that show any other irregularity of any kind, may be rejected as informal.

Should the Bidder in preparing his Bid find anything necessary for the construction of the project that is not mentioned in the Specifications or shown on the Plans, or any discrepancy, he shall notify the Engineer so that such items may be included or corrected. Should the Bidder fail to notify the Engineer of such items, it will be assumed that his Bid included everything necessary for the complete construction of an operating facility in the true spirit and intent of the designs shown.

The "Bidder" shall mean all those Contractors submitting BID FORMS. After the acceptance of the BID FORM of the successful Bidder, the said term "Bidder" shall be interchangeable with the term "Contractor" as defined in the General Conditions and all things required of Bidders shall likewise apply to the Contractor.

2. Supplementary Conditions

The Supplementary Conditions contain the special requirements of the Agency which is funding the subject project or clarifications to the General Conditions.

The Supplementary Conditions shall also be considered an extension of the Instructions to Bidders. Executive Orders, Wage Determination, and any and all other items set out in the Supplementary Conditions shall be used in the preparation of the Bid.



## INSTRUCTIONS TO BIDDERS

October 2019

### 3. Discrepancy - Bid Price

In some instances, there will be space in the BID FORM for the bid price to be written in both words and figures. In such cases, the price written in words shall include both dollars and cents and will be considered the correct price in case of a discrepancy between it and the price written in figures. In case of a discrepancy, the correct total bid price will be considered to be the sum total of amounts bid for all items in the BID FORM. The correct product of the quantity listed in the BID FORM for the said item multiplied by the unit price bid shall be used in the total bid.

### 4. Qualifications of Bidders

The Contractors bidding on the work shall give evidence of their experience in the class of work involved, including at least one job of comparable size and type performed by them as general contractors.

BID FORMS submitted by Contractors who have not, in the opinion of the Engineer and/or Owner, had sufficient experience in the size and type work involved may not be considered.

### 5. Bid Guaranty

The Bidder shall accompany his BID FORM with the BID BOND in the amount not less than five (5%) percent of the amount of his bid executed on the form furnished as a part of the Contract Documents or with a certified check in the amount not less than five (5%) percent of the amount of his bid. A Power of Attorney of the person signing the Bid Bond shall be included. All such documents are subject to approval by the Owner's attorney and the Agency providing funding, if such funding is involved. It is assumed that the Surety Company executing the Bid Bond will also execute the Contract Bond if the Bid is accepted. If this is not to be the case, the approval of the Owner's attorney will be prerequisite to award of the contract. If a certified check is used as Bid Guaranty, the Bidder shall submit the name of his proposed surety with his BID FORM or in writing within five (5) days after being requested to do so.

### 6. Contract Surety; Performance and Payment Bonds

The successful Bidder will be required to furnish both a Performance Bond and a Payment Bond executed by a Surety Company duly authorized to do business in the state in which the work is to be performed and acceptable to the Owner's attorney and the Agency providing funds, if such funding is involved, and each in an amount not less than 100% of the Contract price as security for the faithful performance of this Contract and as security for the payment of all persons performing labor and furnishing materials in connection with this Contract.

## INSTRUCTIONS TO BIDDERS

October 2019

THESE BONDS MUST BE EXECUTED IN THE FORM PROVIDED AS PART OF THE CONTRACT DOCUMENTS.

### 7. Interpretation of Contract Documents

The Project Manual contains the provisions required for the construction of the project. No information obtained from any officer, agent or employee of the Owner on any such matters shall in any way affect the risk or obligation assumed by the Contractor or relieve him from fulfilling any of the conditions of the Contract.

If any Contractor contemplating the submission of a bid for the proposed contract is in doubt as to the true meaning of any part of the Plans, Specifications, or other proposed Contract Documents, he should submit a written request for an interpretation thereof to the office of the ENGINEER advertising the work for bid. The person making the request will be responsible for its prompt delivery. Any interpretation of the Contract Documents will be made only by written communication and in accordance with the time constraints of State Law. The Owner and/or the Engineer will not be responsible for explanation or interpretations of the proposed documents except as issued in accordance herewith.

### 8. Modifications of Bids

Bidders will not be allowed to modify their bids after submission. A bidder may withdraw a mailed bid prior to the bid opening by contacting the Owner; however, neither the Owner nor the Engineer will be responsible for processing this request.

### 9. Second Hand and Salvaged Materials

The use of second hand and/or salvaged materials will not be permitted unless specifically provided for in the Specifications.

### 10. Award of Contract

The Owner reserves the right to reject all bids and to waive informalities. In the event that the lowest Bidder's price overruns the Owner's budget, the Owner reserves the right to negotiate with some of or all Bidders. In the event that the low bid is within the Owner's budget, the Contract will be awarded to the lowest responsive and responsible Bidder.

In determining the lowest responsive and responsible bidder, the following elements will be considered: (1) if the Bidder has a satisfactory performance record, (2) if the Bidder has a suitable financial status to meet obligations

## INSTRUCTIONS TO BIDDERS

October 2019

incidental to the work, (3) if the Bidder involved maintains a permanent place of business, (4) if the Bidder has adequate plant and equipment to perform the work properly within the time allotted, (5) number of and acceptability by the Owner of any and all proposed Subcontractors, (6) if a unit price bid is unbalanced, and (7) the completeness and regularity of the BID FORM. In addition, the Owner may consider in making his determination, (1) the selection of equipment (or materials), (2) alternate equipment (or materials), and (3) deductions or other modifications listed in the BID FORM.

### 11. Execution of Contracts

The construction Contract and Performance and Payment Bond(s) shall be executed by the successful Bidder within the time specified in BID FORM. The number of copies to be executed will be specified in the BID FORM.

### 12. Liquidated Damages for Failure to Enter into Contract

The successful Bidder, upon his failure or refusal to execute and deliver the Contract and Bonds required within ten (10) days after said Bidder has been given written notice of the acceptance of his Bid, shall forfeit to the Owner, as liquidated damages for such failure or refusal, the security deposited with his Bid.

### 13. Insurance, Contractor's Coverage and Cancellation Provision (Also see General Conditions Article 6)

The Contractor will not be permitted to commence work until he has obtained all insurance required by the Contract Documents and such insurance has been approved by the Engineer and/or Owner, nor shall the Contractor allow any Subcontractor to commence work until all similar insurance required of the Subcontractor has been so obtained.

If a Subcontractor does not take out insurance in his own name and his principal Contractor wishes to provide insurance protection for such Subcontractor and such Subcontractor's employees, an endorsement must be attached to the principal Contractor's policy which endorsement must identify the persons thereby covered, or else the principal Contractor must take out appropriate policies in the name of the Subcontractor.

Each policy of insurance covering the Contractor's or Subcontractor's operations under the Contract shall provide, either in the body of the policy, or by appropriate endorsement to the policy, that such policy cannot be altered or canceled in less than thirty (30) days after the receipt of written notice of such alteration or cancellation to the assured (insured) and the Owner and Engineer.

## INSTRUCTIONS TO BIDDERS

October 2019

Certificates of insurance coverages shall include a statement of the alteration or cancellation provision of the policy, sufficient to show definitely that such provisions comply with the requirements stated herein.

THE CONTRACTOR SHALL BE FULLY RESPONSIBLE FOR MAINTAINING THE INSURANCE HEREIN REQUIRED AND SHALL SAVE HARMLESS THE OWNER AND/OR ENGINEER IN THE EVENT HE NEGLECTS OR FAILS TO DO SO FOR ANY REASON. IN THE EVENT THAT THE APPROVED INSURER DOES NOT RENEW THE REQUIRED POLICY AT ANY TIME DURING THE TERM OF THIS CONTRACT, THE CONTRACTOR SHALL CEASE ALL WORK ON THE CONTRACT UNTIL NEW INSURANCE IS ACQUIRED AND APPROVED BY THE OWNER.

14. Insurance: Commercial General Liability, Automobile Liability and Excess Liability (Also see General Conditions Article 6)

The Contractor shall take out and maintain during the life of this contract Commercial General Liability, Automobile Liability, and Excess Liability insurance as shall protect himself and any subcontractor performing work covered under this Contract from claims for damages because of bodily injury, including accidental death, and from claims for property damages that may arise from operations under this Contract, whether such operations be by him or by any subcontractor, or by anyone directly or indirectly employed by either of them.

The Contractor's Commercial or Comprehensive General Liability insurance coverage shall provide coverage on an "occurrence" basis and aggregate limits of insurance on a "per project" basis; and shall specifically include premises and operations; underground, explosion and collapse; products and completed operations maintained two years after completion of the contract; broad form contractual; independent contractors; broad form property damage; and personal injury coverage. If the Comprehensive General Liability Form is used, the policy must include the Broad Form Comprehensive General Liability Endorsement.

Automobile liability insurance must be provided by a Comprehensive Automobile Liability policy covering all owned, hired and non-owned vehicles.

Excess liability insurance must be provided by an Umbrella form on an "occurrence" basis.

The Contractor's Commercial General Liability, Automobile Liability and Excess Liability insurance shall insure the Owner and the Engineer. The insurance coverage of the Owner and the Engineer shall be provided by endorsement that the Owner and the Engineer are additional insureds on the Contractor's General Liability Policy, Automobile Liability Policy and Excess Liability Policy; or by a separate "Owners Protection Policy." If the Owner and the Engineer are listed as

INSTRUCTIONS TO BIDDERS

October 2019

additional insureds on the General Liability Policy, this shall be accomplished using the CG 20-10-11-85 or its equivalent. The Owner and the Engineer shall be listed on the endorsement or separate policy using their respective full legal names.

Minimum limits of coverage shall be as follows:

General Liability

(1)	General Aggregate per Project.....	\$2,000,000
(2)	Each Occurrence .....	\$1,000,000
(3)	Products/Completed Operations Aggregate.....	\$2,000,000
(4)	Medical Expense (any one person).....	\$10,000

Automobile Liability

Combined Single Limit Bodily Injury and Property Damage..... \$1,000,000

Umbrella

Combined Single Limit Bodily Injury and Property Damage \$2,000,000  
(Each Occurrence)

The above does not include special insurance requirements of entities whose property or personnel or other interests are involved; these requirements where applicable will be set forth in the Detailed Specifications.

15. Insurance: Workmen's Compensation and Employer's Liability (Also see General Conditions Article 6)

The Contractor shall take out and maintain, during the life of this contract, Workmen's Compensation and Employer's Liability Insurance, including occupational disease provisions, for all of his employees employed at the site of the project, and in case any work is sublet, the Contractor shall require the subcontractor similarly to provide Workmen's Compensation Insurance and Employer's Liability Insurance, including occupational disease provisions, for all the latter's employees unless such employees are covered by the protection afforded by the Contractor.

In case any class of employees engaged in hazardous work under this contract at the site of the project is not protected under the Tennessee Workmen's Compensation statute, the Contractor shall provide, and shall cause each subcontractor to provide, adequate coverage for the protection of his employees not otherwise protected.

INSTRUCTIONS TO BIDDERS

October 2019

The Workmen's Compensation and Employer's Liability policy shall include the statutory coverage required by the State of Tennessee, United States Longshoreman and Harborworkers Act Endorsement and Voluntary Compensation Endorsement.

Minimum limits of coverage shall be as follows:

Worker's Compensation

Statutory limits required by the State of Tennessee

Employer's Liability

Each Accident .....	\$ 100,000
Disease (policy limit) .....	\$ 500,000
Disease (each employee) .....	\$ 100,000

16. Insurance: Builders Risk (Also see General Conditions Article 6)

The Contractor shall provide Builders Risk Insurance (fire and extended coverage) for 100 percent of the insurable portion of all work in place and/or materials stored at the site. Such insurance shall provide coverage at all times for the full cash value of all completed construction and/or materials stored and shall remain in effect until the covered facilities are accepted by the Owner. Unless otherwise noted, all portions of the construction shall be covered on a 100 percent complete value basis. The Builders Risk Insurance provided by the Contractor shall cover damage to materials and equipment occurring during offloading and/or installation, regardless of the entity performing the offloading and/or installation.

The Contractor will be responsible for any losses covered by the Builder's Risk insurance policy up to the per occurrence deductible amount.

17. Certificate of Insurance (Also see General Conditions Article 6)

As a minimum, the Certificate of Insurance shall contain the following information: (1) name of insurance company, (2) policy number and liability limits on all policies, (3) date of expiration of all policies, (4) statement that ten days' notice of cancellation will be given to the Owner and the Engineer, and (5) statement that coverage that will hold the Owner and Engineer harmless for acts of the Contractor is included.

## INSTRUCTIONS TO BIDDERS

October 2019

### 18. Sanitary Facilities

The Contractor shall furnish, install and maintain ample sanitary facilities for the workmen. As the needs arise, enclosed temporary toilets in sufficient number shall be placed as directed by the Engineer. Permanent toilets installed under this Contract shall not be used during construction. Drinking water shall be provided from a proved safe source, so piped or transported as to be kept clean and fresh and served from single service containers of satisfactory types. The inclusion of this article in no way obligates the Owner or the Engineer to make verification of or to inspect the sanitary facilities and the Contractor shall save the Owner and/or Engineer harmless from any claims arising therefrom.

### 19. Lands and Rights-of-Way

It is anticipated that all easements and land required for the construction of this project will be acquired before the issuance of a Work Order or within the period stipulated in the Advertisement for Bids during which Contractors are not allowed to withdraw their bids. Unless the land(s) and/or easements are obtained or the Contractor agrees to either an extension or a work order stipulating the limitations of work or he may withdraw his bid at the end of such period stipulated in the Advertisement for Bids.

### 20. Commencement and Completion of Work

See General Conditions Article 4.

### 21. Funds for Partial Payment Estimates

See General Conditions Article 15.

### 22. Construction Records and Reports

The Contractor shall, upon request, furnish the Owner with proof that all payrolls for services rendered and invoices for materials supplied have been duly paid as herein required and such other pertinent data as the Owner may require.

The Owner or his authorized representatives and agents shall be permitted to inspect all payrolls, records of personnel, invoices of materials, and other relevant data and records.

On projects involving Federal or State Funds, the Federal or State Agency or Agencies participating in the project shall be considered representatives of the Owner.

## INSTRUCTIONS TO BIDDERS

October 2019

### 23. Payment of Employees

The Contractor and each of his Subcontractors shall pay each of his employees engaged in work on the project in full (less deductions made mandatory by law), in cash (or check), and not less often than once each week.

### 24. Laws and Regulations

The Bidder's attention is directed to the fact that all applicable State laws, municipal ordinances, and the rules and regulations of all authorities having jurisdiction over construction of the project shall apply to the Contract throughout, and they will be deemed to be included in the Contract the same as though herein written out in full.

### 25. Subcontracts

See General Conditions Article 7.

### 26. Ownership of Contractor's License

In addition to the requirements of the laws of the State in which the project is located, no Bid will be accepted from any Contractor who does not propose to accomplish the major portion of the work with his own forces and under his own supervision. No Bids shall be submitted with the intent that an unlicensed Subcontractor will be utilized to construct the major portion of the work. No Bidder shall prepare and submit a Bid under the license of another Contractor. Any misrepresentation which involves submittal of a Bid by one Contractor with the intent that another Contractor will accomplish the work shall be considered grounds for rejection of the BID FORM.

### 27. Wages and Hours and Non-Discrimination

The Contractor shall conform in every respect to applicable rules, regulations and statutes pertaining to wages, hours of work, and non-discrimination. If Federal funding is involved, a section entitled "Supplementary Conditions" together with various attachments and possibly a Wage Determination Decision will be included in these bound documents or may be added by Addendum.

### 28. Drug-Free Workplace Program Requirements

The Contractor shall comply with the requirements of Tennessee Code Annotated, Section 50-9-113 and Title 50, Chapter 9 of the Tennessee Code while performing this contract.



## INSTRUCTIONS TO BIDDERS

October 2019

A written affidavit by the principal officer of the Bidder at the time the Bid is submitted to the Owner shall be submitted by each Bidder with his Bid. The affidavit shall be prepared utilizing the "Drug-Free Workplace Affidavit of Prime Bidder" form provided with the BID FORM.

29. Statement of Compliance Certificate Illegal Immigrants

The Contractor shall comply with the requirements of Tennessee Code Annotated Title 12, Chapter 4, Part 1 of the Tennessee Code while performing this contract.

A written affidavit by the principal officer of the Bidder at the time the Bid is submitted to the Owner shall be submitted by each Bidder with his Bid. The affidavit shall be prepared utilizing the "Statement of Compliance Certificate Illegal Immigrants" form provided with the BID FORM.

30. Compliance with Iran Divestment Act

The Contractor shall comply with the requirements of Tennessee Code Annotated Title 12, Paragraph 12-12-106 of the Tennessee Code while performing this contract.

A written affidavit by the principal officer of the Bidder at the time the Bid is submitted to the Owner shall be submitted by each Bidder with his Bid. The affidavit shall be prepared utilizing the "Statement of Compliance Iran Divestment Act" form provided with the BID FORM.

\*\*\*\*\*

This document has important legal consequences; consultation with an attorney is encouraged with respect to its use or modification. This document should be adapted to the particular circumstances of the contemplated Project and the controlling Laws and Regulations.

## STANDARD GENERAL CONDITIONS OF THE CONSTRUCTION CONTRACT

Prepared By



Endorsed By



Copyright© 2018

National Society of Professional Engineers  
1420 King Street, Alexandria, VA 22314-2794  
(703) 684-2882  
[www.nspe.org](http://www.nspe.org)

American Council of Engineering Companies  
1015 15th Street N.W., Washington, DC 20005  
(202) 347-7474  
[www.acec.org](http://www.acec.org)

American Society of Civil Engineers  
1801 Alexander Bell Drive, Reston, VA 20191-4400  
(800) 548-2723  
[www.asce.org](http://www.asce.org)

The copyright for this EJCDC document is owned jointly by the three sponsoring organizations listed above. The National Society of Professional Engineers is the Copyright Administrator for the EJCDC documents; please direct all inquiries regarding EJCDC copyrights to NSPE.

NOTE: EJCDC publications may be purchased at [www.ejcdc.org](http://www.ejcdc.org), or from any of the sponsoring organizations above.

**This document has been altered by  
J. R. Wauford & Company, Consulting Engineers, Inc.**

# STANDARD GENERAL CONDITIONS OF THE CONSTRUCTION CONTRACT

## TABLE OF CONTENTS

	Page
Article 1—Definitions and Terminology.....	1
1.01 Defined Terms.....	1
1.02 Terminology .....	6
Article 2—Preliminary Matters.....	7
2.01 Delivery of Performance and Payment Bonds; Evidence of Insurance.....	7
2.02 Copies of Documents .....	7
2.03 Before Starting Construction .....	7
2.04 Preconstruction Conference; Designation of Authorized Representatives.....	8
2.05 Acceptance of Schedules .....	8
2.06 Electronic Transmittals .....	8
Article 3—Contract Documents: Intent, Requirements, Reuse.....	9
3.01 Intent.....	9
3.02 Reference Standards.....	9
3.03 Reporting and Resolving Discrepancies .....	10
3.04 Requirements of the Contract Documents.....	11
3.05 Reuse of Documents.....	11
Article 4—Commencement and Progress of the Work .....	11
4.01 Commencement of Contract Times; Notice to Proceed.....	11
4.02 Starting the Work.....	12
4.03 Reference Points.....	12
4.04 Progress Schedule.....	12
4.05 Delays in Contractor’s Progress .....	12
Article 5—Site; Subsurface and Physical Conditions; Hazardous Environmental Conditions .....	14
5.01 Availability of Lands .....	14
5.02 Use of Site and Other Areas.....	14
5.03 Subsurface and Physical Conditions.....	15
5.04 Differing Subsurface or Physical Conditions .....	16

5.05	Underground Facilities.....	18
5.06	Hazardous Environmental Conditions at Site .....	19
Article 6—Bonds and Insurance.....		22
6.01	Performance, Payment, and Other Bonds.....	22
Article 7—Contractor’s Responsibilities .....		29
7.01	Contractor’s Means and Methods of Construction .....	29
7.02	Supervision and Superintendence .....	29
7.03	Labor; Working Hours .....	30
7.04	Services, Materials, and Equipment .....	30
7.05	“Or Equals” .....	30
7.06	Substitutes .....	31
7.07	Concerning Subcontractors and Suppliers.....	33
7.08	Patent Fees and Royalties.....	34
7.09	Permits .....	35
7.10	Taxes .....	35
7.11	Laws and Regulations.....	35
7.12	Record Documents.....	36
7.13	Safety and Protection .....	36
7.14	Hazard Communication Programs .....	37
7.15	Emergencies.....	37
7.16	Submittals .....	37
7.17	Contractor’s General Warranty and Guarantee .....	40
7.18	Indemnification .....	41
7.19	Delegation of Professional Design Services .....	42
Article 8—Other Work at the Site.....		42
8.01	Other Work .....	42
8.02	Coordination .....	43
8.03	Legal Relationships.....	44
Article 9—Owner’s Responsibilities.....		45
9.01	Communications to Contractor .....	45
9.02	Replacement of Engineer.....	45
9.03	Furnish Data .....	45
9.04	Pay When Due.....	45

9.05	Lands and Easements; Reports, Tests, and Drawings.....	45
9.06	Insurance.....	45
9.07	Change Orders .....	45
9.08	Inspections, Tests, and Approvals.....	45
9.09	Limitations on Owner’s Responsibilities .....	45
9.10	Undisclosed Hazardous Environmental Condition.....	46
9.11	Evidence of Financial Arrangements.....	46
9.12	Safety Programs .....	46
Article 10—Engineer’s Status During Construction .....		46
10.01	Owner’s Representative.....	46
10.02	Visits to Site.....	46
10.03	Resident Project Representative.....	46
10.04	Engineer’s Authority .....	47
10.05	Determinations for Unit Price Work .....	47
10.06	Decisions on Requirements of Contract Documents and Acceptability of Work .....	47
10.07	Limitations on Engineer’s Authority and Responsibilities .....	47
10.08	Compliance with Safety Program.....	48
Article 11—Changes to the Contract .....		48
11.01	Amending and Supplementing the Contract .....	48
11.02	Change Orders .....	48
11.03	Work Change Directives.....	49
11.04	Field Orders.....	49
11.05	Owner-Authorized Changes in the Work.....	49
11.06	Unauthorized Changes in the Work.....	50
11.07	Change of Contract Price .....	50
11.08	Change of Contract Times.....	51
11.09	Change Proposals.....	51
11.10	Notification to Surety.....	52
Article 12—Claims.....		52
12.01	Claims.....	52
Article 13—Cost of the Work; Allowances; Unit Price Work .....		54
13.01	Cost of the Work .....	54
13.02	Allowances .....	57

13.03	Unit Price Work .....	57
Article 14—	Tests and Inspections; Correction, Removal, or Acceptance of Defective Work .....	58
14.01	Access to Work.....	58
14.02	Tests, Inspections, and Approvals.....	58
14.03	Defective Work .....	59
14.04	Acceptance of Defective Work.....	60
14.05	Uncovering Work .....	60
14.06	Owner May Stop the Work .....	60
14.07	Owner May Correct Defective Work.....	61
Article 15—	Payments to Contractor; Set-Offs; Completion; Correction Period .....	61
15.01	Progress Payments.....	61
15.02	Contractor’s Warranty of Title .....	64
15.03	Substantial Completion.....	64
15.04	Partial Use or Occupancy .....	65
15.05	Final Inspection .....	65
15.06	Final Payment.....	66
15.07	Waiver of Claims .....	67
15.08	Correction Period .....	67
Article 16—	Suspension of Work and Termination .....	68
16.01	Owner May Suspend Work .....	68
16.02	Owner May Terminate for Cause.....	68
16.03	Owner May Terminate for Convenience.....	69
16.04	Contractor May Stop Work or Terminate .....	70
Article 17—	Final Resolution of Disputes .....	70
17.01	Methods and Procedures.....	70
Article 18—	Miscellaneous .....	71
18.01	Giving Notice .....	71
18.02	Computation of Times.....	71
18.03	Cumulative Remedies .....	71
18.04	Limitation of Damages .....	71
18.05	No Waiver .....	71
18.06	Survival of Obligations .....	71
18.07	Controlling Law .....	71

18.08 Assignment of Contract..... 72  
18.09 Successors and Assigns ..... 72  
18.10 Headings..... 72



# STANDARD GENERAL CONDITIONS OF THE CONSTRUCTION CONTRACT

## ARTICLE 1—DEFINITIONS AND TERMINOLOGY

### 1.01 *Defined Terms*

- A. Wherever used in the Bidding Requirements or Contract Documents, a term printed with initial capital letters, including the term's singular and plural forms, will have the meaning indicated in the definitions below. In addition to terms specifically defined, terms with initial capital letters in the Contract Documents include references to identified articles and paragraphs, and the titles of other documents or forms.
1. *Addenda*—Written or graphic instruments issued prior to the opening of Bids which clarify, correct, or change the Bidding Requirements or the proposed Contract Documents.
  2. *Agreement*—The written instrument, executed by Owner and Contractor, that sets forth the Contract Price and Contract Times, identifies the parties and the Engineer, and designates the specific items that are Contract Documents.
  3. *Application for Payment*—The document prepared by Contractor, in a form acceptable to Engineer, to request progress or final payments, and which is to be accompanied by such supporting documentation as is required by the Contract Documents.
  4. *Bid*—The offer of a Bidder submitted on the prescribed form setting forth the prices for the Work to be performed.
  5. *Bidder*—An individual or entity that submits a Bid to Owner.
  6. *Bidding Documents*—The Bidding Requirements, the proposed Contract Documents, and all Addenda.
  7. *Bidding Requirements*—The Advertisement or invitation to bid, Instructions to Bidders, Bid Bond or other Bid security, if any, the Bid Form, and the Bid with any attachments.
  8. *Change Order*—A document which is signed by Contractor and Owner and authorizes an addition, deletion, or revision in the Work or an adjustment in the Contract Price or the Contract Times, or other revision to the Contract, issued on or after the Effective Date of the Contract.
  9. *Change Proposal*—A written request by Contractor, duly submitted in compliance with the procedural requirements set forth herein, seeking an adjustment in Contract Price or Contract Times; contesting an initial decision by Engineer concerning the requirements of the Contract Documents or the acceptability of Work under the Contract Documents; challenging a set-off against payments due; or seeking other relief with respect to the terms of the Contract.
  10. *Claim*
    - a. A demand or assertion by Owner directly to Contractor, duly submitted in compliance with the procedural requirements set forth herein, seeking an adjustment of Contract Price or Contract Times; contesting an initial decision by Engineer concerning the

- requirements of the Contract Documents or the acceptability of Work under the Contract Documents; contesting Engineer's decision regarding a Change Proposal; seeking resolution of a contractual issue that Engineer has declined to address; or seeking other relief with respect to the terms of the Contract.
- b. A demand or assertion by Contractor directly to Owner, duly submitted in compliance with the procedural requirements set forth herein, contesting Engineer's decision regarding a Change Proposal, or seeking resolution of a contractual issue that Engineer has declined to address.
  - c. A demand or assertion by Owner or Contractor, duly submitted in compliance with the procedural requirements set forth herein, made pursuant to Paragraph 12.01.A.4, concerning disputes arising after Engineer has issued a recommendation of final payment.
  - d. A demand for money or services by a third party is not a Claim.
11. *Constituent of Concern*—Asbestos, petroleum, radioactive materials, polychlorinated biphenyls (PCBs), lead-based paint (as defined by the HUD/EPA standard), hazardous waste, and any substance, product, waste, or other material of any nature whatsoever that is or becomes listed, regulated, or addressed pursuant to Laws and Regulations regulating, relating to, or imposing liability or standards of conduct concerning, any hazardous, toxic, or dangerous waste, substance, or material.
  12. *Contract*—The entire and integrated written contract between Owner and Contractor concerning the Work.
  13. *Contract Documents*—Those items so designated in the Agreement, and which together comprise the Contract.
  14. *Contract Price*—The money that Owner has agreed to pay Contractor for completion of the Work in accordance with the Contract Documents.
  15. *Contract Times*—The number of days or the dates by which Contractor shall: (a) achieve Milestones, if any; (b) achieve Substantial Completion; and (c) complete the Work.
  16. *Contractor*—The individual or entity with which Owner has contracted for performance of the Work.
  17. *Cost of the Work*—See Paragraph 13.01 for definition.
  18. *Drawings or Plans*—The part of the Contract that graphically shows the scope, extent, and character of the Work to be performed by Contractor.
  19. *Effective Date of the Contract*—The date, indicated in the Agreement, on which the Contract becomes effective.
  20. *Electronic Document*—Any Project-related correspondence, attachments to correspondence, data, documents, drawings, information, or graphics, including but not limited to Shop Drawings and other Submittals, that are in an electronic or digital Portable Document Format (PDF).
  21. *Electronic Means*—Electronic mail (email), upload/download from a secure Project website, or other communications methods that allow: (a) the transmission or communication of Electronic Documents; (b) the documentation of transmissions,

including sending and receipt; (c) printing of the transmitted Electronic Document by the recipient; (d) the storage and archiving of the Electronic Document by sender and recipient; and (e) the use by recipient of the Electronic Document for purposes permitted by this Contract. Electronic Means does not include the use of text messaging, or of Facebook, Twitter, Instagram, or similar social media services for transmission of Electronic Documents.

22. *Engineer*—The individual or entity named as such in the Agreement.
23. *Field Order*—A written order issued by Engineer which requires minor changes in the Work but does not change the Contract Price or the Contract Times.
24. *Hazardous Environmental Condition*—The presence at the Site of Constituents of Concern in such quantities or circumstances that may present a danger to persons or property exposed thereto.
  - a. The presence at the Site of materials that are necessary for the execution of the Work, or that are to be incorporated into the Work, and that are controlled and contained pursuant to industry practices, Laws and Regulations, and the requirements of the Contract, is not a Hazardous Environmental Condition.
  - b. The presence of Constituents of Concern that are to be removed or remediated as part of the Work is not a Hazardous Environmental Condition.
  - c. The presence of Constituents of Concern as part of the routine, anticipated, and obvious working conditions at the Site, is not a Hazardous Environmental Condition.
25. *Laws and Regulations; Laws or Regulations*—Any and all applicable laws, statutes, rules, regulations, ordinances, codes, and binding decrees, resolutions, and orders of any and all governmental bodies, agencies, authorities, and courts having jurisdiction.
26. *Liens*—Charges, security interests, or encumbrances upon Contract-related funds, real property, or personal property.
27. *Milestone*—A principal event in the performance of the Work that the Contract requires Contractor to achieve by an intermediate completion date, or by a time prior to Substantial Completion of all the Work.
28. *Notice of Award*—The written notice by Owner or the Engineer to a Bidder of Owner's acceptance of the Bid.
29. *Notice to Proceed*—A written notice by Owner or the Engineer at the Owner's discretion to Contractor fixing the date on which the Contract Times will commence to run and on which Contractor shall start to perform the Work.
30. *Owner*—The individual or entity with which Contractor has contracted regarding the Work, and which has agreed to pay Contractor for the performance of the Work, pursuant to the terms of the Contract.
31. *Progress Schedule*—A schedule, prepared and maintained by Contractor, describing the sequence and duration of the activities comprising Contractor's plan to accomplish the Work within the Contract Times.

32. *Project*—The total undertaking to be accomplished for Owner by engineers, contractors, and others, including planning, study, design, construction, testing, commissioning, and start-up, and of which the Work to be performed under the Contract Documents is a part.
- 32a. *Project Manual* - The written documents prepared for, or made available for, procuring and constructing the Work, including but not limited to the Bidding Documents or other construction procurement documents, geotechnical and existing conditions information, the Agreement, bond forms, General Conditions, Supplementary Conditions, and Specifications. The contents of the Project Manual may be bound in one or more volumes.
33. *Resident Project Representative*—The authorized representative of Engineer assigned to assist Engineer at the Site. As used herein, the term Resident Project Representative (RPR) includes any assistants or field staff of Resident Project Representative.
34. *Samples*—Physical examples of materials, equipment, or workmanship that are representative of some portion of the Work and that establish the standards by which such portion of the Work will be judged.
35. *Schedule of Submittals*—A schedule, prepared and maintained by Contractor, of required submittals and the time requirements for Engineer’s review of the submittals.
36. *Schedule of Values*—A schedule, prepared and maintained by Contractor, allocating portions of the Contract Price to various portions of the Work and used as the basis for reviewing Contractor’s Applications for Payment.
37. *Shop Drawings*—All drawings, diagrams, illustrations, schedules, and other data or information that are specifically prepared or assembled by or for Contractor and submitted by Contractor to illustrate some portion of the Work. Shop Drawings, whether approved or not, are not Drawings and are not Contract Documents.
38. *Site*—Lands or areas indicated in the Contract Documents as being furnished by Owner upon which the Work is to be performed, including rights-of-way and easements, and such other lands or areas furnished by Owner which are designated for the use of Contractor.
39. *Specifications*—The part of the Contract that consists of written requirements for materials, equipment, systems, standards, and workmanship as applied to the Work, and certain administrative requirements and procedural matters applicable to the Work.
40. *Subcontractor*—An individual or entity having a direct contract with Contractor or with any other Subcontractor for the performance of a part of the Work.
41. *Submittal*—A written or graphic document, prepared by or for Contractor, which the Contract Documents require Contractor to submit to Engineer, or that is indicated as a Submittal in the Schedule of Submittals accepted by Engineer. Submittals may include Shop Drawings and Samples; schedules; product data; Owner-delegated designs; sustainable design information; information on special procedures; testing plans; results of tests and evaluations, source quality-control testing and inspections, and field or Site quality-control testing and inspections; warranties and certifications; Suppliers’ instructions and reports; records of delivery of spare parts and tools; operations and maintenance data; Project photographic documentation; record documents; and other such documents required by the Contract Documents. Submittals, whether or not approved or accepted by Engineer, are not Contract Documents. Change Proposals,

Change Orders, Claims, notices, Applications for Payment, and requests for interpretation or clarification are not Submittals.

42. *Substantial Completion*—The time at which the Work (or a specified part thereof) has progressed to the point where, in the opinion of Engineer, the Work (or a specified part thereof) is sufficiently complete, in accordance with the Contract Documents, so that the Work (or a specified part thereof) can be utilized for the purposes for which it is intended. The terms “substantially complete” and “substantially completed” as applied to all or part of the Work refer to Substantial Completion of such Work.
43. *Successful Bidder*—The Bidder to which the Owner makes an award of contract.
44. *Supplementary Conditions*—The part of the Contract that amends or supplements these General Conditions.
45. *Supplier*—A manufacturer, fabricator, supplier, distributor, or vendor having a direct contract with Contractor or with any Subcontractor to furnish materials or equipment to be incorporated in the Work by Contractor or a Subcontractor.
46. *Technical Data*
  - a. Those items expressly identified as Technical Data in the Supplementary Conditions, with respect to either (1) existing subsurface conditions at or adjacent to the Site, or existing physical conditions at or adjacent to the Site including existing surface or subsurface structures (except Underground Facilities) or (2) Hazardous Environmental Conditions at the Site.
  - b. If no such express identifications of Technical Data have been made with respect to conditions at the Site, then Technical Data is defined, with respect to conditions at the Site under Paragraphs 5.03, 5.04, and 5.06, as the data contained in boring logs, recorded measurements of subsurface water levels, assessments of the condition of subsurface facilities, laboratory test results, and other factual, objective information regarding conditions at the Site that are set forth in any geotechnical, environmental, or other Site or facilities conditions report prepared for the Project and made available to Contractor.
47. *Underground Facilities*—All active underground lines, pipelines, conduits, ducts, encasements, cables, wires, manholes, vaults, tanks, tunnels, or other such facilities or systems at the Site, including but not limited to those facilities or systems that produce, transmit, distribute, or convey telephone or other communications, cable television, fiber optic transmissions, power, electricity, light, heat, gases, oil, crude oil products, liquid petroleum products, water, steam, waste, wastewater, storm water, other liquids or chemicals, or traffic or other control systems. An abandoned facility or system is not an Underground Facility.
48. *Unit Price Work*—Work to be paid for on the basis of unit prices.
49. *Work*—The entire construction or the various separately identifiable parts thereof required to be provided under the Contract Documents. Work includes and is the result of performing or providing all labor, services, and documentation necessary to produce such construction; furnishing, installing, and incorporating all materials and equipment into such construction; and may include related services such as testing, start-up, and commissioning, all as required by the Contract Documents.

50. *Work Change Directive*—A written directive to Contractor issued on or after the Effective Date of the Contract, signed by Owner and recommended by Engineer, ordering an addition, deletion, or revision in the Work.

## 1.02 Terminology

- A. The words and terms discussed in Paragraphs 1.02.B, C, D, and E are not defined terms that require initial capital letters, but, when used in the Bidding Requirements or Contract Documents, have the indicated meaning.
- B. *Intent of Certain Terms or Adjectives*: The Contract Documents include the terms “as allowed,” “as approved,” “as ordered,” “as directed” or terms of like effect or import to authorize an exercise of professional judgment by Engineer. In addition, the adjectives “reasonable,” “suitable,” “acceptable,” “proper,” “satisfactory,” or adjectives of like effect or import are used to describe an action or determination of Engineer as to the Work. It is intended that such exercise of professional judgment, action, or determination will be solely to evaluate, in general, the Work for compliance with the information in the Contract Documents and with the design concept of the Project as a functioning whole as shown or indicated in the Contract Documents (unless there is a specific statement indicating otherwise). The use of any such term or adjective is not intended to and shall not be effective to assign to Engineer any duty or authority to supervise or direct the performance of the Work, or any duty or authority to undertake responsibility contrary to the provisions of Article 10 or any other provision of the Contract Documents.
- C. *Day*: The word “day” means a calendar day of 24 hours measured from midnight to the next midnight.
- D. *Defective*: The word “defective,” when modifying the word “Work,” refers to Work that is unsatisfactory, faulty, or deficient in that it:
1. does not conform to the Contract Documents;
  2. does not meet the requirements of any applicable inspection, reference standard, test, or approval referred to in the Contract Documents; or
  3. has been damaged prior to Engineer’s recommendation of final payment (unless responsibility for the protection thereof has been assumed by Owner at Substantial Completion in accordance with Paragraph 15.03 or Paragraph 15.04).
- E. *Furnish, Install, Perform, Provide*
1. The word “furnish,” when used in connection with services, materials, or equipment, means to supply and deliver said services, materials, or equipment to the Site (or some other specified location) ready for use or installation and in usable or operable condition.
  2. The word “install,” when used in connection with services, materials, or equipment, means to put into use or place in final position said services, materials, or equipment complete and ready for intended use.
  3. The words “perform” or “provide,” when used in connection with services, materials, or equipment, means to furnish and install said services, materials, or equipment complete and ready for intended use.
  4. If the Contract Documents establish an obligation of Contractor with respect to specific services, materials, or equipment, but do not expressly use any of the four words

“furnish,” “install,” “perform,” or “provide,” then Contractor shall furnish and install said services, materials, or equipment complete and ready for intended use.

- F. *Contract Price or Contract Times*: References to a change in “Contract Price or Contract Times” or “Contract Times or Contract Price” or similar, indicate that such change applies to (1) Contract Price, (2) Contract Times, or (3) both Contract Price and Contract Times, as warranted, even if the term “or both” is not expressed.
- G. Unless stated otherwise in the Contract Documents, words or phrases that have a well-known technical or construction industry or trade meaning are used in the Contract Documents in accordance with such recognized meaning.

## **ARTICLE 2—PRELIMINARY MATTERS**

### **2.01 *Delivery of Performance and Payment Bonds; Evidence of Insurance***

- A. *Performance and Payment Bonds*: When Contractor delivers the signed counterparts of the Agreement to Owner, Contractor shall also deliver to Owner the performance bond and payment bond (if the Contract requires Contractor to furnish such bonds).
- B. *Evidence of Contractor’s Insurance*: When Contractor delivers the signed counterparts of the Agreement to Owner, Contractor shall also deliver to Owner, with copies to each additional insured (as identified in the Contract), the certificates, endorsements, and other evidence of insurance required to be provided by Contractor in accordance with Article 6, except to the extent the Supplementary Conditions expressly establish other dates for delivery of specific insurance policies.
- C. *Evidence of Owner’s Insurance*: After receipt of the signed counterparts of the Agreement and all required bonds and insurance documentation, Owner shall promptly deliver to Contractor, with copies to each additional insured (as identified in the Contract), the certificates and other evidence of insurance required to be provided by Owner under Article 6.

### **2.02 *Copies of Documents***

- A. Owner shall furnish to Contractor two copies of the executed Contract Documents, one of which Contractor shall furnish to Contractor’s Surety.
- B. Owner shall furnish to Contractor up to ten printed or hard copies of the Drawings and Project Manual. Additional copies will be furnished upon request at the cost of reproduction.

### **2.03 *Before Starting Construction***

- A. *Preliminary Schedules*: Within 10 days after the Effective Date of the Contract (or as otherwise required by the Contract Documents), Contractor shall submit to Engineer for timely review:
  - 1. a preliminary Progress Schedule indicating the times (numbers of days or dates) for starting and completing the various stages of the Work, including any Milestones specified in the Contract;
  - 2. a preliminary Schedule of Submittals; and
  - 3. a preliminary Schedule of Values for all of the Work which includes quantities and prices of items which when added together equal the Contract Price and subdivides the Work into component parts in sufficient detail to serve as the basis for progress payments

during performance of the Work. Such prices will include an appropriate amount of overhead and profit applicable to each item of Work.

2.04 *Preconstruction Conference; Designation of Authorized Representatives*

- A. Before any Work at the Site is started, a conference attended by Owner, Contractor, Engineer, and others as appropriate will be held to establish a working understanding among the parties as to the Work, and to discuss the schedules referred to in Paragraph 2.03.A, procedures for handling Shop Drawings, Samples, and other Submittals, processing Applications for Payment, electronic or digital transmittals, and maintaining required records.
- B. At this conference Owner and Contractor each shall designate, in writing, a specific individual to act as its authorized representative with respect to the services and responsibilities under the Contract. Such individuals shall have the authority to transmit and receive information, render decisions relative to the Contract, and otherwise act on behalf of each respective party.

2.05 *Acceptance of Schedules*

- A. At least 10 days before submission of the first Application for Payment a conference, attended by Contractor, Engineer, and others as appropriate, will be held to review the schedules submitted in accordance with Paragraph 2.03.A. It is the Contractor's responsibility to request and schedule said meeting or waive right thereto. No progress payment will be made to Contractor until acceptable schedules are submitted to Engineer.
  - 1. The Progress Schedule will be acceptable to Engineer if it provides an orderly progression of the Work to completion within the Contract Times. Such acceptance will not impose on Engineer responsibility for the Progress Schedule, for sequencing, scheduling, or progress of the Work, nor interfere with or relieve Contractor from Contractor's full responsibility therefor.
  - 2. Contractor's Schedule of Submittals will be acceptable to Engineer if it provides a workable arrangement for reviewing and processing the required submittals.
  - 3. Contractor's Schedule of Values will be acceptable to Engineer as to form and substance if it provides a reasonable allocation of the Contract Price to the component parts of the Work.
  - 4. If a schedule is not acceptable, Contractor will have an additional 10 days to revise and resubmit the schedule.

2.06 *Electronic Transmittals*

- A. Except as otherwise stated elsewhere in the Contract, the Owner, Engineer, and Contractor may send, and shall accept, Electronic Documents transmitted by Electronic Means.
- B. If the Contract does not establish protocols for Electronic Means, then Owner, Engineer, and Contractor shall jointly develop such protocols.
- C. Subject to any governing protocols for Electronic Means, when transmitting Electronic Documents by Electronic Means, the transmitting party makes no representations as to long-term compatibility, usability, or readability of the Electronic Documents resulting from the recipient's use of software application packages, operating systems, or computer hardware differing from those used in the drafting or transmittal of the Electronic Documents.



- D. Project Manuals and Drawings issued by the Engineer for bidding purposes may be Electronic Documents or printed copies (also known as hard copies) as determined by the Engineer.
- E. Project Manuals and Drawings issued by the Engineer for construction purposes shall be printed copies (also known as hard copies). At the request of the Contractor, the Engineer may provide Electronic Documents of Project Manuals and Drawings issued by the Engineer for construction purposes; however, said Electronic Documents are provided for the convenience of the receiving party. Any conclusion or information obtained or derived from the Electronic Documents will be at the user's sole risk. If there is a discrepancy between the Electronic Documents and the hard copies, the hard copies shall govern.

### **ARTICLE 3—CONTRACT DOCUMENTS: INTENT, REQUIREMENTS, REUSE**

#### **3.01 *Intent***

- A. The Contract Documents are complementary; what is required by one Contract Document is as binding as if required by all.
- B. It is the intent of the Contract Documents to describe a functionally complete Project (or part thereof) to be constructed in accordance with the Contract Documents.
- C. Unless otherwise stated in the Contract Documents, if there is a discrepancy between the electronic versions of the Contract Documents (including any printed copies derived from such electronic versions) and the printed record version, the printed record version will govern.
- D. The Contract supersedes prior negotiations, representations, and agreements, whether written or oral.
- E. Engineer will issue clarifications and interpretations of the Contract Documents as provided herein.
- F. Any provision or part of the Contract Documents held to be void or unenforceable under any Law or Regulation will be deemed stricken, and all remaining provisions will continue to be valid and binding upon Owner and Contractor, which agree that the Contract Documents will be reformed to replace such stricken provision or part thereof with a valid and enforceable provision that comes as close as possible to expressing the intention of the stricken provision.
- G. Nothing in the Contract Documents creates:
  - 1. any contractual relationship between Owner or Engineer and any Subcontractor, Supplier, or other individual or entity performing or furnishing any of the Work, for the benefit of such Subcontractor, Supplier, or other individual or entity; or
  - 2. any obligation on the part of Owner or Engineer to pay or to see to the payment of any money due any such Subcontractor, Supplier, or other individual or entity, except as may otherwise be required by Laws and Regulations.

#### **3.02 *Reference Standards***

- A. *Standards Specifications, Codes, Laws and Regulations*
  - 1. Reference in the Contract Documents to standard specifications, manuals, reference standards, or codes of any technical society, organization, or association, or to Laws or Regulations, whether such reference be specific or by implication, means the standard

specification, manual, reference standard, code, or Laws or Regulations in effect at the time of opening of Bids (or on the Effective Date of the Contract if there were no Bids), except as may be otherwise specifically stated in the Contract Documents.

2. No provision of any such standard specification, manual, reference standard, or code, and no instruction of a Supplier, will be effective to change the duties or responsibilities of Owner, Contractor, or Engineer from those set forth in the part of the Contract Documents prepared by or for Engineer. No such provision or instruction shall be effective to assign to Owner or Engineer any duty or authority to supervise or direct the performance of the Work, or any duty or authority to undertake responsibility inconsistent with the provisions of the part of the Contract Documents prepared by or for Engineer.

### 3.03 *Reporting and Resolving Discrepancies*

#### A. *Reporting Discrepancies*

1. *Contractor's Verification of Figures and Field Measurements:* Before undertaking each part of the Work, Contractor shall carefully study the Contract Documents, and check and verify pertinent figures and dimensions therein, particularly with respect to applicable field measurements. Contractor shall promptly report in writing to Engineer any conflict, error, ambiguity, or discrepancy that Contractor discovers, or has actual knowledge of, and shall not proceed with any Work affected thereby until the conflict, error, ambiguity, or discrepancy is resolved by a clarification or interpretation by Engineer, or by an amendment or supplement to the Contract issued pursuant to Paragraph 11.01.
2. *Contractor's Review of Contract Documents:* If, before or during the performance of the Work, Contractor discovers any conflict, error, ambiguity, or discrepancy within the Contract Documents, or between the Contract Documents and (a) any applicable Law or Regulation, (b) actual field conditions, (c) any standard specification, manual, reference standard, or code, or (d) any instruction of any Supplier, then Contractor shall promptly report it to Engineer in writing. Contractor shall not proceed with the Work affected thereby (except in an emergency as required by Paragraph 7.15) until the conflict, error, ambiguity, or discrepancy is resolved, by a clarification or interpretation by Engineer, or by an amendment or supplement to the Contract issued pursuant to Paragraph 11.01.
3. Contractor shall not be liable to Owner or Engineer for failure to report any conflict, error, ambiguity, or discrepancy in the Contract Documents unless Contractor had actual knowledge thereof.

#### B. *Resolving Discrepancies*

1. Except as may be otherwise specifically stated in the Contract Documents, the provisions of the part of the Contract Documents prepared by or for Engineer take precedence in resolving any conflict, error, ambiguity, or discrepancy between such provisions of the Contract Documents and:
  - a. the provisions of any standard specification, manual, reference standard, or code, or the instruction of any Supplier (whether or not specifically incorporated by reference as a Contract Document); or

- b. the provisions of any Laws or Regulations applicable to the performance of the Work (unless such an interpretation of the provisions of the Contract Documents would result in violation of such Law or Regulation).

3.04 *Requirements of the Contract Documents*

- A. During the performance of the Work and until final payment, Contractor and Owner shall submit to the Engineer in writing all matters in question concerning the requirements of the Contract Documents (sometimes referred to as requests for information or interpretation—RFIs) or relating to the acceptability of the Work under the Contract Documents, as soon as possible after such matters arise. Engineer will be the initial interpreter of the requirements of the Contract Documents, and judge of the acceptability of the Work.
- B. Engineer will, with reasonable promptness, render a written clarification, interpretation, or decision on the issue submitted, or initiate an amendment or supplement to the Contract Documents. Engineer's written clarification, interpretation, or decision will be final and binding on Contractor, unless it appeals by submitting a Change Proposal, and on Owner, unless it appeals by filing a Claim.
- C. If a submitted matter in question concerns terms and conditions of the Contract Documents that do not involve (1) the performance or acceptability of the Work under the Contract Documents, (2) the design (as set forth in the Drawings, Specifications, or otherwise), or (3) other engineering or technical matters, then Engineer will promptly notify Owner and Contractor in writing that Engineer is unable to provide a decision or interpretation. If Owner and Contractor are unable to agree on resolution of such a matter in question, either party may pursue resolution as provided in Article 12.

3.05 *Reuse of Documents*

- A. Contractor and its Subcontractors and Suppliers shall not:
  - 1. have or acquire any title to or ownership rights in any of the Drawings, Specifications, or other documents (or copies of any thereof) prepared by or bearing the seal of Engineer or its consultants, including electronic media versions, or reuse any such Drawings, Specifications, other documents, or copies thereof on extensions of the Project or any other project without written consent of Owner and Engineer and specific written verification or adaptation by Engineer; or
  - 2. have or acquire any title or ownership rights in any other Contract Documents, reuse any such Contract Documents for any purpose without Owner's express written consent, or violate any copyrights pertaining to such Contract Documents.
- B. The prohibitions of this Paragraph 3.05 will survive final payment, or termination of the Contract. Nothing herein precludes Contractor from retaining copies of the Contract Documents for record purposes.

**ARTICLE 4—COMMENCEMENT AND PROGRESS OF THE WORK**

4.01 *Commencement of Contract Times; Notice to Proceed*

- A. The Contract Times will commence to run on the day indicated in the Notice to Proceed. A Notice to Proceed may be given at any time within 90 days after the Effective Date of the

Contract. The Contractor shall advise the Owner and Engineer related to scheduling and equipment/material delivery dates related to a delayed Notice to Proceed.

4.02 *Starting the Work*

- A. Contractor shall start to perform the Work on the date when the Contract Times commence to run. No Work may be done at the Site prior to such date unless agreed to in writing by the Owner.

4.03 *Reference Points*

- A. Owner shall provide engineering surveys to establish reference points for construction which in Engineer's judgment are necessary to enable Contractor to proceed with the Work. Contractor shall be responsible for laying out the Work, shall protect and preserve the established reference points and property monuments, and shall make no changes or relocations without the prior written approval of Owner. Contractor shall report to Engineer whenever any reference point or property monument is lost or destroyed or requires relocation because of necessary changes in grades or locations and shall be responsible for the accurate replacement or relocation of such reference points or property monuments by professionally qualified personnel.

4.04 *Progress Schedule*

- A. Contractor shall adhere to the Progress Schedule established in accordance with Paragraph 2.05 as it may be adjusted from time to time as provided below.
  - 1. Contractor shall submit to Engineer for acceptance (to the extent indicated in Paragraph 2.05) proposed adjustments in the Progress Schedule that will not result in changing the Contract Times.
  - 2. Proposed adjustments in the Progress Schedule that will change the Contract Times must be submitted in accordance with the requirements of Article 11.
- B. Contractor shall carry on the Work and adhere to the Progress Schedule during all disputes or disagreements with Owner. No Work will be delayed or postponed pending resolution of any disputes or disagreements, or during any appeal process, except as permitted by Paragraph 16.04, or as Owner and Contractor may otherwise agree in writing.

4.05 *Delays in Contractor's Progress*

- A. If Owner, Engineer, or anyone for whom Owner is responsible, delays, disrupts, or interferes with the performance or progress of the Work, then Contractor shall be entitled to an equitable adjustment in Contract Price or Contract Times.
- B. Contractor shall not be entitled to an adjustment in Contract Price or Contract Times for delay, disruption, or interference caused by or within the control of Contractor. Delay, disruption, and interference attributable to and within the control of a Subcontractor or Supplier shall be deemed to be within the control of Contractor.
- C. If Contractor's performance or progress is delayed, disrupted, or interfered with by unanticipated causes not the fault of and beyond the control of Owner, Contractor, and those for which they are responsible, then Contractor shall be entitled to an equitable adjustment in Contract Times. Such an adjustment will be Contractor's sole and exclusive remedy for the delays, disruption, and interference described in this paragraph. Causes of delay, disruption,

or interference that may give rise to an adjustment in Contract Times under this paragraph include but are not limited to the following:

1. Severe and unavoidable natural catastrophes such as fires, floods, epidemics, and earthquakes;
  2. Abnormal weather conditions;
  3. Acts or failures to act of third-party utility owners or other third-party entities (other than those third-party utility owners or other third-party entities performing other work at or adjacent to the Site as arranged by or under contract with Owner, as contemplated in Article 8); and
  4. Acts of war or terrorism.
- D. Contractor's entitlement to an adjustment of Contract Times or Contract Price is limited as follows:
1. Contractor's entitlement to an adjustment of the Contract Times is conditioned on the delay, disruption, or interference adversely affecting an activity on the critical path to completion of the Work, as of the time of the delay, disruption, or interference.
  2. Contractor shall not be entitled to an adjustment in Contract Price for any delay, disruption, or interference if such delay is concurrent with a delay, disruption, or interference caused by or within the control of Contractor. Such a concurrent delay by Contractor shall not preclude an adjustment of Contract Times to which Contractor is otherwise entitled.
  3. Adjustments of Contract Times or Contract Price are subject to the provisions of Article 11.
- E. Each Contractor request or Change Proposal seeking an increase in Contract Times or Contract Price must be supplemented by supporting data that sets forth in detail the following:
1. The circumstances that form the basis for the requested adjustment;
  2. The date upon which each cause of delay, disruption, or interference began to affect the progress of the Work;
  3. The date upon which each cause of delay, disruption, or interference ceased to affect the progress of the Work;
  4. The number of days' increase in Contract Times claimed as a consequence of each such cause of delay, disruption, or interference; and
  5. The impact on Contract Price, in accordance with the provisions of Paragraph 11.07.

Contractor shall also furnish such additional supporting documentation as Owner or Engineer may require including, where appropriate, a revised progress schedule indicating all the activities affected by the delay, disruption, or interference, and an explanation of the effect of the delay, disruption, or interference on the critical path to completion of the Work.

- F. Delays, disruption, and interference to the performance or progress of the Work resulting from the existence of a differing subsurface or physical condition, an Underground Facility that was not shown or indicated by the Contract Documents, or not shown or indicated with

reasonable accuracy, and those resulting from Hazardous Environmental Conditions, are governed by Article 5, together with the provisions of Paragraphs 4.05.D and 4.05.E.

- G. Paragraph 8.03 addresses delays, disruption, and interference to the performance or progress of the Work resulting from the performance of certain other work at or adjacent to the Site.
- H. Contractor shall submit any Change Proposal seeking adjustment in the Contract Price or Contract Times within 30 days of the commencement of the delaying, disrupting, or interfering event.

## **ARTICLE 5—SITE; SUBSURFACE AND PHYSICAL CONDITIONS; HAZARDOUS ENVIRONMENTAL CONDITIONS**

### **5.01 Availability of Lands**

- A. Owner shall furnish the Site. Owner shall notify Contractor in writing of any encumbrances or restrictions not of general application but specifically related to use of the Site with which Contractor must comply in performing the Work.
- B. Upon reasonable written request, Owner shall furnish Contractor with a current statement of record legal title and legal description of the lands upon which permanent improvements are to be made and Owner's interest therein as necessary for giving notice of or filing a mechanic's or construction lien against such lands in accordance with applicable Laws and Regulations.
- C. Contractor shall provide for all additional lands and access thereto that may be required for temporary construction facilities or storage of materials and equipment.

### **5.02 Use of Site and Other Areas**

#### **A. Limitation on Use of Site and Other Areas**

1. Contractor shall confine construction equipment, temporary construction facilities, the storage of materials and equipment, and the operations of workers to the Site, adjacent areas that Contractor has arranged to use through construction easements or otherwise, and other adjacent areas permitted by Laws and Regulations, and shall not unreasonably encumber the Site and such other adjacent areas with construction equipment or other materials or equipment. Contractor shall assume full responsibility for (a) damage to the Site; (b) damage to any such other adjacent areas used for Contractor's operations; (c) damage to any other adjacent land or areas, or to improvements, structures, utilities, or similar facilities located at such adjacent lands or areas; and (d) for injuries and losses sustained by the owners or occupants of any such land or areas; provided that such damage or injuries result from the performance of the Work or from other actions or conduct of the Contractor or those for which Contractor is responsible.
2. If a damage or injury claim is made by the owner or occupant of any such land or area because of the performance of the Work, or because of other actions or conduct of the Contractor or those for which Contractor is responsible, Contractor shall (a) take immediate corrective or remedial action as required by Paragraph 7.13, or otherwise; (b) promptly attempt to settle the claim as to all parties through negotiations with such owner or occupant, or otherwise resolve the claim by arbitration or other dispute resolution proceeding, or in a court of competent jurisdiction; and (c) to the fullest extent permitted by Laws and Regulations, indemnify and hold harmless Owner and Engineer, and the officers, directors, members, partners, employees, agents, consultants and

subcontractors of each and any of them, from and against any such claim, and against all costs, losses, and damages (including but not limited to all fees and charges of engineers, architects, attorneys, and other professionals and all court or arbitration or other dispute resolution costs) arising out of or relating to any claim or action, legal or equitable, brought by any such owner or occupant against Owner, Engineer, or any other party indemnified hereunder to the extent caused directly or indirectly, in whole or in part by, or based upon, Contractor's performance of the Work, or because of other actions or conduct of the Contractor or those for which Contractor is responsible.

- B. *Removal of Debris During Performance of the Work:* During the progress of the Work the Contractor shall keep the Site and other adjacent areas free from accumulations of waste materials, rubbish, and other debris. Removal and disposal of such waste materials, rubbish, and other debris will conform to applicable Laws and Regulations.
- C. *Cleaning:* Prior to Substantial Completion of the Work Contractor shall clean the Site and the Work and make it ready for utilization by Owner. At the completion of the Work Contractor shall remove from the Site and adjacent areas all tools, appliances, construction equipment and machinery, and surplus materials and shall restore to original condition all property not designated for alteration by the Contract Documents.
- D. *Loading of Structures:* Contractor shall not load nor permit any part of any structure to be loaded in any manner that will endanger the structure, nor shall Contractor subject any part of the Work or adjacent structures or land to stresses or pressures that will endanger them.

### 5.03 *Subsurface and Physical Conditions*

- A. *Reports and Drawings:* The Supplementary Conditions identify:
  - 1. Those reports provided by Owner of explorations and tests of subsurface conditions at or adjacent to the Site that contain Technical Data;
  - 2. Those drawings provided by Owner of existing physical conditions at or adjacent to the Site, including those drawings depicting existing surface or subsurface structures at or adjacent to the Site (except Underground Facilities), that contain Technical Data; and
  - 3. Technical Data contained in such reports and drawings.
- B. *Underground Facilities:* Underground Facilities are shown or indicated on the Drawings, pursuant to Paragraph 5.05, and not in the drawings referred to in Paragraph 5.03.A. Information and data regarding the presence or location of Underground Facilities are not intended to be categorized, identified, or defined as Technical Data.
- C. *Reliance by Contractor on Technical Data:* Contractor may rely upon the accuracy of the Technical Data expressly identified in the Supplementary Conditions with respect to such reports and drawings, but such reports and drawings are not Contract Documents. If no such express identification has been made, then Contractor may rely upon the accuracy of the Technical Data as defined in Paragraph 1.01.A.46.b.
- D. *Limitations of Other Data and Documents:* Except for such reliance on Technical Data, Contractor may not rely upon or make any claim against Owner or Engineer, or any of their

officers, directors, members, partners, employees, agents, consultants, or subcontractors, with respect to:

1. the completeness of such reports and drawings for Contractor's purposes, including, but not limited to, any aspects of the means, methods, techniques, sequences, and procedures of construction to be employed by Contractor, and safety precautions and programs incident thereto;
2. other data, interpretations, opinions, and information contained in such reports or shown or indicated in such drawings;
3. the contents of other Site-related documents made available to Contractor, such as record drawings from other projects at or adjacent to the Site, or Owner's archival documents concerning the Site; or
4. any Contractor interpretation of or conclusion drawn from any Technical Data or any such other data, interpretations, opinions, or information.

5.04 *Differing Subsurface or Physical Conditions*

A. *Notice by Contractor:* If Contractor believes that any subsurface or physical condition that is uncovered or revealed at the Site:

1. is of such a nature as to establish that any Technical Data on which Contractor is entitled to rely as provided in Paragraph 5.03 is materially inaccurate;
2. is of such a nature as to require a change in the Drawings or Specifications;
3. differs materially from that shown or indicated in the Contract Documents; or
4. is of an unusual nature, and differs materially from conditions ordinarily encountered and generally recognized as inherent in work of the character provided for in the Contract Documents;

then Contractor shall, promptly after becoming aware thereof and before further disturbing the subsurface or physical conditions or performing any Work in connection therewith (except in an emergency as required by Paragraph 7.15), notify Owner and Engineer in writing about such condition. Contractor shall not further disturb such condition or perform any Work in connection therewith (except with respect to an emergency) until receipt of a written statement permitting Contractor to do so.

B. *Engineer's Review:* After receipt of written notice as required by the preceding paragraph, Engineer will promptly review the subsurface or physical condition in question; determine whether it is necessary for Owner to obtain additional exploration or tests with respect to the condition; conclude whether the condition falls within any one or more of the differing site condition categories in Paragraph 5.04.A; obtain any pertinent cost or schedule information from Contractor; prepare recommendations to Owner regarding the Contractor's resumption of Work in connection with the subsurface or physical condition in question and the need for any change in the Drawings or Specifications; and advise Owner in writing of Engineer's findings, conclusions, and recommendations.

C. *Owner's Statement to Contractor Regarding Site Condition:* After receipt of Engineer's written findings, conclusions, and recommendations, Owner shall issue a written statement to Contractor (with a copy to Engineer) regarding the subsurface or physical condition in question, addressing the resumption of Work in connection with such condition, indicating



whether any change in the Drawings or Specifications will be made, and adopting or rejecting Engineer's written findings, conclusions, and recommendations, in whole or in part.

- D. *Early Resumption of Work*: If at any time Engineer determines that Work in connection with the subsurface or physical condition in question may resume prior to completion of Engineer's review or Owner's issuance of its statement to Contractor, because the condition in question has been adequately documented, and analyzed on a preliminary basis, then the Engineer may at its discretion instruct Contractor to resume such Work.
- E. *Possible Price and Times Adjustments*
1. Contractor shall be entitled to an equitable adjustment in Contract Price or Contract Times, to the extent that the existence of a differing subsurface or physical condition, or any related delay, disruption, or interference, causes an increase or decrease in Contractor's cost of, or time required for, performance of the Work; subject, however, to the following:
    - a. Such condition must fall within any one or more of the categories described in Paragraph 5.04.A;
    - b. With respect to Work that is paid for on a unit price basis, any adjustment in Contract Price will be subject to the provisions of Paragraph 13.03; and,
    - c. Contractor's entitlement to an adjustment of the Contract Times is subject to the provisions of Paragraphs 4.05.D, 4.05.E, and 4.05.H.
  2. Contractor shall not be entitled to any adjustment in the Contract Price or Contract Times with respect to a subsurface or physical condition if:
    - a. Contractor knew of the existence of such condition at the time Contractor made a commitment to Owner with respect to Contract Price and Contract Times by the submission of a Bid or becoming bound under a negotiated contract, or otherwise;
    - b. The existence of such condition reasonably could have been discovered or revealed as a result of any examination, investigation, exploration, test, or study of the Site and contiguous areas expressly required by the Bidding Requirements or Contract Documents to be conducted by or for Contractor prior to Contractor's making such commitment; or
    - c. Contractor failed to give the written notice required by Paragraph 5.04.A.
  3. If Owner and Contractor agree regarding Contractor's entitlement to and the amount or extent of any adjustment in the Contract Price or Contract Times, then any such adjustment will be set forth in a Change Order.
  4. Contractor may submit a Change Proposal regarding its entitlement to or the amount or extent of any adjustment in the Contract Price or Contract Times, no later than 30 days after Owner's issuance of the Owner's written statement to Contractor regarding the subsurface or physical condition in question.
- F. *Underground Facilities; Hazardous Environmental Conditions*: Paragraph 5.05 governs rights and responsibilities regarding the presence or location of Underground Facilities. Paragraph 5.06 governs rights and responsibilities regarding Hazardous Environmental Conditions. The provisions of Paragraphs 5.03 and 5.04 are not applicable to the presence or location of Underground Facilities, or to Hazardous Environmental Conditions.

## 5.05 *Underground Facilities*

- A. *Contractor's Responsibilities:* Owner and Engineer do not warrant or guarantee the accuracy or completeness of any such information or data provided by others. Unless it is otherwise expressly provided in the Supplementary Conditions, the cost of all of the following are included in the Contract Price, and Contractor shall have full responsibility for:
1. reviewing and checking all information and data regarding existing Underground Facilities at the Site;
  2. complying with applicable state and local utility damage prevention Laws and Regulations;
  3. verifying the actual location of those Underground Facilities shown or indicated in the Contract Documents as being within the area affected by the Work, by exposing such Underground Facilities during the course of construction;
  4. coordination of the Work with the owners (including Owner) of such Underground Facilities, during construction; and
  5. the safety and protection of all existing Underground Facilities at the Site, and repairing any damage thereto resulting from the Work.
- B. *Notice by Contractor:* If Contractor believes that an Underground Facility that is uncovered or revealed at the Site was not shown or indicated on the Drawings, or was not shown or indicated on the Drawings with reasonable accuracy, then Contractor shall, promptly after becoming aware thereof and before further disturbing conditions affected thereby or performing any Work in connection therewith (except in an emergency as required by Paragraph 7.15), notify Owner and Engineer in writing regarding such Underground Facility.
- C. *Engineer's Review:* Engineer will:
1. promptly review the Underground Facility and conclude whether such Underground Facility was not shown or indicated on the Drawings, or was not shown or indicated with reasonable accuracy;
  2. prepare recommendations to Owner (and if necessary issue any preliminary instructions to Contractor) regarding the Contractor's resumption of Work in connection with the Underground Facility in question;
  3. obtain any pertinent cost or schedule information from Contractor; determine the extent, if any, to which a change is required in the Drawings or Specifications to reflect and document the consequences of the existence or location of the Underground Facility; and
  4. advise Owner in writing of Engineer's findings, conclusions, and recommendations.
- During such time, Contractor shall be responsible for the safety and protection of such Underground Facility.
- D. *Owner's Statement to Contractor Regarding Underground Facility:* After receipt of Engineer's written findings, conclusions, and recommendations, Owner shall issue a written statement to Contractor (with a copy to Engineer) regarding the Underground Facility in question addressing the resumption of Work in connection with such Underground Facility, indicating whether any change in the Drawings or Specifications will be made, and adopting or rejecting Engineer's written findings, conclusions, and recommendations in whole or in part.

- E. *Early Resumption of Work*: If at any time Engineer determines that Work in connection with the Underground Facility may resume prior to completion of Engineer's review or Owner's issuance of its statement to Contractor, because the Underground Facility in question and conditions affected by its presence have been adequately documented, and analyzed on a preliminary basis, then the Engineer may at its discretion instruct Contractor to resume such Work.
- F. *Possible Price and Times Adjustments*
1. Contractor shall be entitled to an equitable adjustment in the Contract Price or Contract Times, to the extent that any existing Underground Facility at the Site that was not shown or indicated on the Drawings, or was not shown or indicated with reasonable accuracy, or any related delay, disruption, or interference, causes an increase or decrease in Contractor's cost of, or time required for, performance of the Work; subject, however, to the following:
    - a. With respect to Work that is paid for on a unit price basis, any adjustment in Contract Price will be subject to the provisions of Paragraph 13.03;
    - b. Contractor's entitlement to an adjustment of the Contract Times is subject to the provisions of Paragraphs 4.05.D and 4.05.E;
    - c. Contractor gave the notice required in Paragraph 5.05.B; and
    - d. Contractor did not know and could not reasonably have been expected to be aware of or to have anticipated the existence or actual location of the Underground Facility in question.
  2. If Owner and Contractor agree regarding Contractor's entitlement to and the amount or extent of any adjustment in the Contract Price or Contract Times, then any such adjustment will be set forth in a Change Order.
  3. Contractor may submit a Change Proposal regarding its entitlement to or the amount or extent of any adjustment in the Contract Price or Contract Times, no later than 30 days after Owner's issuance of the Owner's written statement to Contractor regarding the Underground Facility in question.
  4. The information and data shown or indicated on the Drawings with respect to existing Underground Facilities at the Site is based on information and data (a) furnished by the owners of such Underground Facilities, or by others, (b) obtained from available records, or (c) gathered in an investigation conducted in accordance with the current edition of ASCE 38, Standard Guideline for the Collection and Depiction of Existing Subsurface Utility Data, by the American Society of Civil Engineers. If such information or data is incorrect or incomplete, Contractor's remedies are limited to those set forth in this Paragraph 5.05.F.

5.06 *Hazardous Environmental Conditions at Site*

- A. *Reports and Drawings*: The Supplementary Conditions identify:
1. those reports known to Owner relating to Hazardous Environmental Conditions that have been identified at or adjacent to the Site;
  2. drawings known to Owner relating to Hazardous Environmental Conditions that have been identified at or adjacent to the Site; and

3. Technical Data contained in such reports and drawings.
- B. *Reliance by Contractor on Technical Data Authorized:* Contractor may rely upon the accuracy of the Technical Data expressly identified in the Supplementary Conditions with respect to such reports and drawings, but such reports and drawings are not Contract Documents. If no such express identification has been made, then Contractor may rely on the accuracy of the Technical Data as defined in Paragraph 1.01.A.46.b. Except for such reliance on Technical Data, Contractor may not rely upon or make any claim against Owner or Engineer, or any of their officers, directors, members, partners, employees, agents, consultants, or subcontractors, with respect to:
1. the completeness of such reports and drawings for Contractor's purposes, including, but not limited to, any aspects of the means, methods, techniques, sequences and procedures of construction to be employed by Contractor, and safety precautions and programs incident thereto;
  2. other data, interpretations, opinions, and information contained in such reports or shown or indicated in such drawings; or
  3. any Contractor interpretation of or conclusion drawn from any Technical Data or any such other data, interpretations, opinions or information.
- C. Contractor shall not be responsible for removing or remediating any Hazardous Environmental Condition encountered, uncovered, or revealed at the Site unless such removal or remediation is expressly identified in the Contract Documents to be within the scope of the Work.
- D. Contractor shall be responsible for controlling, containing, and duly removing all Constituents of Concern brought to the Site by Contractor, Subcontractors, Suppliers, or anyone else for whom Contractor is responsible, and for any associated costs; and for the costs of removing and remediating any Hazardous Environmental Condition created by the presence of any such Constituents of Concern.
- E. If Contractor encounters, uncovers, or reveals a Hazardous Environmental Condition whose removal or remediation is not expressly identified in the Contract Documents as being within the scope of the Work, or if Contractor or anyone for whom Contractor is responsible creates a Hazardous Environmental Condition, then Contractor shall immediately: (1) secure or otherwise isolate such condition; (2) stop all Work in connection with such condition and in any area affected thereby (except in an emergency as required by Paragraph 7.15); and (3) notify Owner and Engineer (and promptly thereafter confirm such notice in writing). Owner shall promptly consult with Engineer concerning the necessity for Owner to retain a qualified expert to evaluate such condition or take corrective action, if any. Promptly after consulting with Engineer, Owner shall take such actions as are necessary to permit Owner to timely obtain required permits and provide Contractor the written notice required by Paragraph 5.06.F. If Contractor or anyone for whom Contractor is responsible created the Hazardous Environmental Condition in question, then Owner may remove and remediate the Hazardous Environmental Condition and impose a set-off against payments to account for the associated costs.
- F. Contractor shall not resume Work in connection with such Hazardous Environmental Condition or in any affected area until after Owner has obtained any required permits related thereto, and delivered written notice to Contractor either (1) specifying that such condition

- and any affected area is or has been rendered safe for the resumption of Work, or (2) specifying any special conditions under which such Work may be resumed safely.
- G. If Owner and Contractor cannot agree as to entitlement to or on the amount or extent, if any, of any adjustment in Contract Price or Contract Times, as a result of such Work stoppage, such special conditions under which Work is agreed to be resumed by Contractor, or any costs or expenses incurred in response to the Hazardous Environmental Condition, then within 30 days of Owner's written notice regarding the resumption of Work, Contractor may submit a Change Proposal, or Owner may impose a set-off. Entitlement to any such adjustment is subject to the provisions of Paragraphs 4.05.D, 4.05.E, 11.07, and 11.08.
  - H. If, after receipt of such written notice, Contractor does not agree to resume such Work based on a reasonable belief it is unsafe, or does not agree to resume such Work under such special conditions, then Owner may order the portion of the Work that is in the area affected by such condition to be deleted from the Work, following the contractual change procedures in Article 11. Owner may have such deleted portion of the Work performed by Owner's own forces or others in accordance with Article 8.
  - I. To the fullest extent permitted by Laws and Regulations, Owner shall indemnify and hold harmless Contractor, Subcontractors, and Engineer, and the officers, directors, members, partners, employees, agents, consultants, and subcontractors of each and any of them, from and against all claims, costs, losses, and damages (including but not limited to all fees and charges of engineers, architects, attorneys, and other professionals, and all court, arbitration, or other dispute resolution costs) arising out of or relating to a Hazardous Environmental Condition, provided that such Hazardous Environmental Condition (1) was not shown or indicated in the Drawings, Specifications, or other Contract Documents, identified as Technical Data entitled to limited reliance pursuant to Paragraph 5.06.B, or identified in the Contract Documents to be included within the scope of the Work, and (2) was not created by Contractor or by anyone for whom Contractor is responsible. Nothing in this Paragraph 5.06.I obligates Owner to indemnify any individual or entity from and against the consequences of that individual's or entity's own negligence.
  - J. To the fullest extent permitted by Laws and Regulations, Contractor shall indemnify and hold harmless Owner and Engineer, and the officers, directors, members, partners, employees, agents, consultants, and subcontractors of each and any of them, from and against all claims, costs, losses, and damages (including but not limited to all fees and charges of engineers, architects, attorneys, and other professionals and all court or arbitration or other dispute resolution costs) arising out of or relating to the failure to control, contain, or remove a Constituent of Concern brought to the Site by Contractor or by anyone for whom Contractor is responsible, or to a Hazardous Environmental Condition created by Contractor or by anyone for whom Contractor is responsible. Nothing in this Paragraph 5.06.J obligates Contractor to indemnify any individual or entity from and against the consequences of that individual's or entity's own negligence.
  - K. The provisions of Paragraphs 5.03, 5.04, and 5.05 do not apply to the presence of Constituents of Concern or to a Hazardous Environmental Condition uncovered or revealed at the Site.

## ARTICLE 6—BONDS AND INSURANCE

### 6.01 *Performance, Payment, and Other Bonds*

- A. Contractor shall furnish a performance bond and a payment bond, each in an amount at least equal to the Contract Price, as security for the faithful performance and payment of all of Contractor's obligations under the Contract. These bonds shall remain in effect until one year after the date when final payment becomes due or until completion of the correction period specified in Paragraph 15.08, whichever is later, except as provided otherwise by Laws or Regulations, the Supplementary Conditions, or other specific provisions of the Contract. Contractor shall also furnish such other bonds as are required by the Supplementary Conditions or other specific provisions of the Contract.
- B. All bonds shall be in the form prescribed by the Contract except as provided otherwise by Laws or Regulations, and shall be executed by such sureties as are named in "Companies Holding Certificates of Authority as Acceptable Sureties on Federal Bonds and as Acceptable Reinsuring Companies" as published in Circular 570 (as amended and supplemented) by the Financial Management Service, Surety Bond Branch, U.S. Department of the Treasury. A bond signed by an agent or attorney-in-fact must be accompanied by a certified copy of that individual's authority to bind the surety. The evidence of authority shall show that it is effective on the date the agent or attorney-in-fact signed the accompanying bond.
- C. Contractor shall obtain the required bonds from surety companies that are duly licensed or authorized in the jurisdiction in which the Project is located to issue bonds in the required amounts.
- D. If the surety on a bond furnished by Contractor is declared bankrupt or becomes insolvent, or its right to do business is terminated in any state or jurisdiction where any part of the Project is located, or the surety ceases to meet the requirements above, then Contractor shall promptly notify Owner and Engineer and shall, within 20 days after the event giving rise to such notification, provide another bond and surety, both of which shall comply with the bond and surety requirements above.
- E. If Contractor has failed to obtain a required bond, Owner may exclude the Contractor from the Site and exercise Owner's termination rights under Article 16.
- F. Upon request, Owner shall provide a copy of the payment bond to any Subcontractor, Supplier, or other person or entity claiming to have furnished labor or materials used in the performance of the Work.

### 6.02 *Insurance—General Provisions*

- A. Owner and Contractor shall obtain and maintain insurance as required in this Article and in the Supplementary Conditions.
- B. All insurance required by the Contract to be purchased and maintained by Owner or Contractor shall be obtained from insurance companies that are duly licensed or authorized, in the state or jurisdiction in which the Project is located, to issue insurance policies for the required limits and coverages. Unless a different standard is indicated in the Supplementary Conditions, all companies that provide insurance policies required under this Contract shall have an A.M. Best rating of A-VII or better.

- C. Contractor shall deliver to Owner, with copies to each named insured and additional insured (as identified in this Article, in the Supplementary Conditions, or elsewhere in the Contract), certificates of insurance establishing that Contractor has obtained and is maintaining the policies, coverages, and endorsements required by the Contract. Upon request by Owner or any other insured, Contractor shall also furnish other evidence of such required insurance, including but not limited to copies of policies and endorsements, and documentation of applicable self-insured retentions and deductibles. Contractor may block out (redact) any confidential premium or pricing information contained in any policy or endorsement furnished under this provision.
- D. Owner shall deliver to Contractor, with copies to each named insured and additional insured (as identified in this Article, the Supplementary Conditions, or elsewhere in the Contract), certificates of insurance establishing that Owner has obtained and is maintaining the policies, coverages, and endorsements required of Owner by the Contract (if any). Upon request by Contractor or any other insured, Owner shall also provide other evidence of such required insurance (if any), including but not limited to copies of policies and endorsements, and documentation of applicable self-insured retentions and deductibles. Owner may block out (redact) any confidential premium or pricing information contained in any policy or endorsement furnished under this provision.
- E. Failure of Owner or Contractor to demand such certificates or other evidence of the other party's full compliance with these insurance requirements, or failure of Owner or Contractor to identify a deficiency in compliance from the evidence provided, shall not be construed as a waiver of the other party's obligation to obtain and maintain such insurance.
- F. If either party does not purchase or maintain all of the insurance required of such party by the Contract, such party shall notify the other party in writing of such failure to purchase prior to the start of the Work, or of such failure to maintain prior to any change in the required coverage.
- G. If Contractor has failed to obtain and maintain required insurance, Owner may exclude the Contractor from the Site, impose an appropriate set-off against payment, and exercise Owner's termination rights under Article 16.
- H. Without prejudice to any other right or remedy, if a party has failed to obtain required insurance, the other party may elect to obtain equivalent insurance to protect such other party's interests at the expense of the party who was required to provide such coverage, and the Contract Price shall be adjusted accordingly.
- I. Owner does not represent that insurance coverage and limits established in this Contract necessarily will be adequate to protect Contractor or Contractor's interests.
- J. The insurance and insurance limits required herein shall not be deemed as a limitation on Contractor's liability under the indemnities granted to Owner and other individuals and entities in the Contract.

### 6.03 *Contractor's Insurance*

- A. *Workers' Compensation:* Contractor shall purchase and maintain workers' compensation and employer's liability insurance for:
  - 1. claims under workers' compensation, disability benefits, and other similar employee benefit acts.

2. United States Longshoreman and Harbor Workers' Compensation Act and Jones Act coverage (if applicable).
  3. claims for damages because of bodily injury, occupational sickness or disease, or death of Contractor's employees.
  4. Foreign voluntary worker compensation (if applicable).
- B. *Commercial General Liability—Claims Covered:* Contractor shall purchase and maintain commercial general liability insurance, covering all operations by or on behalf of Contractor, on an occurrence basis, against:
1. claims for damages because of bodily injury, sickness or disease, or death of any person other than Contractor's employees.
  2. claims for damages insured by reasonably available personal injury liability coverage.
  3. claims for damages, other than to the Work itself, because of injury to or destruction of tangible property wherever located, including loss of use resulting therefrom.
- C. *Commercial General Liability—Form and Content:* Contractor's commercial liability policy shall be written on a 1996 (or later) ISO commercial general liability form (occurrence form) and include the following coverages and endorsements:
1. Products and completed operations coverage:
    - a. Such insurance shall be maintained until the end of the warranty (guarantee) period.
    - b. Contractor shall furnish Owner and each other additional insured (as identified in the Supplementary Conditions or elsewhere in the Contract) evidence of continuation of such insurance until the end of the warranty (guarantee) period.
  2. Blanket contractual liability coverage, to the extent permitted by law, including but not limited to coverage of Contractor's contractual indemnity obligations in Paragraph 7.18.
  3. Broad form property damage coverage.
  4. Severability of interest.
  5. Underground, explosion, and collapse coverage.
  6. Personal injury coverage.
  7. Additional insured endorsements that include both ongoing operations and products and completed operations coverage through ISO Endorsements CG 20 10 10 01 and CG 20 37 10 01 (together); or CG 20 10 07 04 and CG 20 37 07 04 (together); or their equivalent.
  8. For design professional additional insureds, ISO Endorsement CG 20 32 07 04, "Additional Insured—Engineers, Architects or Surveyors Not Engaged by the Named Insured" or its equivalent.
- D. *Automobile liability:* Contractor shall purchase and maintain automobile liability insurance against claims for damages because of bodily injury or death of any person or property damage arising out of the ownership, maintenance, or use of any motor vehicle. The automobile liability policy shall be written on an occurrence basis.
- E. *Umbrella or excess liability:* Contractor shall purchase and maintain umbrella or excess liability insurance written over the underlying employer's liability, commercial general liability, and



automobile liability insurance described in the paragraphs above. Subject to industry-standard exclusions, the coverage afforded shall follow form as to each and every one of the underlying policies.

- F. *Contractor's pollution liability insurance:* Contractor shall purchase and maintain a policy covering third-party injury and property damage claims, including clean-up costs, as a result of pollution conditions arising from Contractor's operations and completed operations. This insurance shall be maintained for no less than three years after final completion.
- G. *Additional insureds:* The Contractor's commercial general liability, automobile liability, umbrella or excess, and pollution liability policies shall include and list as additional insureds Owner and Engineer, and any individuals or entities identified in the Supplementary Conditions; include coverage for the respective officers, directors, members, partners, employees, agents, consultants, and subcontractors of each and any of all such additional insureds; and the insurance afforded to these additional insureds shall provide primary coverage for all claims covered thereby (including as applicable those arising from both ongoing and completed operations) on a non-contributory basis. Contractor shall obtain all necessary endorsements to support these requirements.
- H. *Contractor's professional liability insurance:* If Contractor will provide or furnish professional services under this Contract, through a delegation of professional design services or otherwise, then Contractor shall be responsible for purchasing and maintaining applicable professional liability insurance. This insurance shall provide protection against claims arising out of performance of professional design or related services, and caused by a negligent error, omission, or act for which the insured party is legally liable. It shall be maintained throughout the duration of the Contract and for a minimum of the end of the warranty (guarantee) period. If such professional design services are performed by a Subcontractor, and not by Contractor itself, then the requirements of this paragraph may be satisfied through the purchasing and maintenance of such insurance by such Subcontractor.
- I. *General provisions:* The policies of insurance required by this Paragraph 6.03 shall:
  - 1. include at least the specific coverages provided in this Article.
  - 2. be written for not less than the limits of liability provided in this Article and in the Supplementary Conditions, or required by Laws or Regulations, whichever is greater.
  - 3. contain a provision or endorsement that the coverage afforded will not be canceled, materially changed, or renewal refused until at least 10 days prior written notice has been given to Contractor. Within three days of receipt of any such written notice, Contractor shall provide a copy of the notice to Owner, Engineer, and each other insured under the policy.
  - 4. remain in effect at least until the end of the warranty (guarantee) period and at all times thereafter when Contractor may be correcting, removing, or replacing defective Work as a warranty or correction obligation, or otherwise, or returning to the Site to conduct other tasks arising from the Contract Documents.
  - 5. be appropriate for the Work being performed and provide protection from claims that may arise out of or result from Contractor's performance of the Work and Contractor's other obligations under the Contract Documents, whether it is to be performed by Contractor, any Subcontractor or Supplier, or by anyone directly or indirectly employed

by any of them to perform any of the Work, or by anyone for whose acts any of them may be liable.

- J. *The coverage requirements for specific policies of insurance must be met by such policies, and not by reference to excess or umbrella insurance provided in other policies.*

#### 6.04 *Owner's Liability Insurance*

- A. In addition to the insurance required to be provided by Contractor under Paragraph 6.03, Owner, at Owner's option, may purchase and maintain at Owner's expense Owner's own liability insurance as will protect Owner against claims which may arise from operations under the Contract Documents.
- B. Owner's liability policies, if any, operate separately and independently from policies required to be provided by Contractor, and Contractor cannot rely upon Owner's liability policies for any of Contractor's obligations to the Owner, Engineer, or third parties.

#### 6.05 *Property Insurance*

- A. *Builder's Risk:* Unless otherwise provided in the Supplementary Conditions, Contractor shall purchase and maintain builder's risk insurance upon the Work on a completed value basis, in the amount of the full insurable replacement cost thereof (subject to such deductible amounts as may be provided in the Supplementary Conditions or required by Laws and Regulations). This insurance shall:
1. include the Owner and Contractor as named insureds, and all Subcontractors, and any individuals or entities required by the Supplementary Conditions to be insured under such builder's risk policy, as insureds or named insureds. For purposes of the remainder of this Paragraph 6.05, Paragraphs 6.06 and 6.07, and any corresponding Supplementary Conditions, the parties required to be insured shall collectively be referred to as "insureds."
  2. be written on a builder's risk "all risk" policy form that shall at least include insurance for physical loss or damage to the Work, temporary buildings, falsework, and materials and equipment in transit, and shall insure against at least the following perils or causes of loss: fire; lightning; windstorm; riot; civil commotion; terrorism; vehicle impact; aircraft; smoke; theft; vandalism and malicious mischief; mechanical breakdown, boiler explosion, and artificially generated electric current; earthquake; volcanic activity, and other earth movement; flood; collapse; explosion; debris removal; demolition occasioned by enforcement of Laws and Regulations; water damage (other than that caused by flood); and such other perils or causes of loss as may be specifically required by the Supplementary Conditions. If insurance against mechanical breakdown, boiler explosion, and artificially generated electric current; earthquake; volcanic activity, and other earth movement; or flood, are not commercially available under builder's risk policies, by endorsement or otherwise, such insurance may be provided through other insurance policies acceptable to Owner and Contractor.
  3. cover, as insured property, at least the following: (a) the Work and all materials, supplies, machinery, apparatus, equipment, fixtures, and other property of a similar nature that are to be incorporated into or used in the preparation, fabrication, construction, erection, or completion of the Work, including Owner-furnished or assigned property; (b) spare parts inventory required within the scope of the Contract; and (c) temporary works which are not intended to form part of the permanent constructed Work but which are intended

to provide working access to the Site, or to the Work under construction, or which are intended to provide temporary support for the Work under construction, including scaffolding, form work, fences, shoring, falsework, and temporary structures.

4. cover expenses incurred in the repair or replacement of any insured property (including but not limited to fees and charges of engineers and architects).
  5. extend to cover damage or loss to insured property while in temporary storage at the Site or in a storage location outside the Site (but not including property stored at the premises of a manufacturer or Supplier).
  6. extend to cover damage or loss to insured property while in transit.
  7. allow for partial occupation or use of the Work by Owner, such that those portions of the Work that are not yet occupied or used by Owner shall remain covered by the builder's risk insurance.
  8. allow for the waiver of the insurer's subrogation rights, as set forth below.
  9. provide primary coverage for all losses and damages caused by the perils or causes of loss covered.
  10. not include a co-insurance clause.
  11. include an exception for ensuing losses from physical damage or loss with respect to any defective workmanship, design, or materials exclusions.
  12. include performance/hot testing and start-up.
  13. be maintained in effect, subject to the provisions herein regarding Substantial Completion and partial occupancy or use of the Work by Owner, until the Work is complete.
- B. *Notice of Cancellation or Change:* All the policies of insurance (and the certificates or other evidence thereof) required to be purchased and maintained in accordance with this Paragraph 6.05 shall contain a provision or endorsement that the coverage afforded will not be canceled or materially changed or renewal refused until at least 10 days prior written notice has been given to the purchasing policyholder. Within three days of receipt of any such written notice, the purchasing policyholder shall provide a copy of the notice to each other insured.
- C. *Deductibles:* The purchaser of any required builder's risk or property insurance shall pay for costs not covered because of the application of a policy deductible.
- D. *Partial Occupancy or Use by Owner:* If Owner will occupy or use a portion or portions of the Work prior to Substantial Completion of all the Work as provided in Paragraph 15.04, then Owner (directly, if it is the purchaser of the builder's risk policy, or through Contractor) will provide notice of such occupancy or use to the builder's risk insurer. The builder's risk insurance shall not be canceled or permitted to lapse on account of any such partial use or occupancy; rather, those portions of the Work that are occupied or used by Owner may come off the builder's risk policy, while those portions of the Work not yet occupied or used by Owner shall remain covered by the builder's risk insurance.
- E. *Additional Insurance:* If Contractor elects to obtain other special insurance to be included in or supplement the builder's risk or property insurance policies provided under this Paragraph 6.05, it may do so at Contractor's expense.

- F. *Insurance of Other Property*: If the express insurance provisions of the Contract do not require or address the insurance of a property item or interest, such as tools, construction equipment, or other personal property owned by Contractor, a Subcontractor, or an employee of Contractor or a Subcontractor, then the entity or individual owning such property item shall be responsible for deciding whether to insure it, and if so in what amount.

6.06 *Waiver of Rights*

- A. All policies purchased in accordance with Paragraph 6.05, expressly including the builder's risk policy, shall contain provisions to the effect that in the event of payment of any loss or damage the insurers will have no rights of recovery against any insureds thereunder, or against Engineer or its consultants, or their officers, directors, members, partners, employees, agents, consultants, or subcontractors. Owner and Contractor waive all rights against each other and the respective officers, directors, members, partners, employees, agents, consultants, and subcontractors of each and any of them, for all losses and damages caused by, arising out of, or resulting from any of the perils or causes of loss covered by such policies and any other property insurance applicable to the Work; and, in addition, waive all such rights against Engineer, its consultants, all Subcontractors, all individuals or entities identified in the Supplementary Conditions as insureds, and the officers, directors, members, partners, employees, agents, consultants, and subcontractors of each and any of them, under such policies for losses and damages so caused. None of the above waivers shall extend to the rights that any party making such waiver may have to the proceeds of insurance held by Owner or Contractor as trustee or fiduciary, or otherwise payable under any policy so issued.
- B. Owner waives all rights against Contractor, Subcontractors, and Engineer, and the officers, directors, members, partners, employees, agents, consultants and subcontractors of each and any of them, for:
  - 1. loss due to business interruption, loss of use, or other consequential loss extending beyond direct physical loss or damage to Owner's property or the Work caused by, arising out of, or resulting from fire or other perils whether or not insured by Owner; and
  - 2. loss or damage to the completed Project or part thereof caused by, arising out of, or resulting from fire or other insured peril or cause of loss covered by any property insurance maintained on the completed Project or part thereof by Owner during partial occupancy or use pursuant to Paragraph 15.04, after Substantial Completion pursuant to Paragraph 15.03, or after final payment pursuant to Paragraph 15.06.
- C. Any insurance policy maintained by Owner covering any loss, damage or consequential loss referred to in Paragraph 6.06.B shall contain provisions to the effect that in the event of payment of any such loss, damage, or consequential loss, the insurers will have no rights of recovery against Contractor, Subcontractors, or Engineer, or the officers, directors, members, partners, employees, agents, consultants, or subcontractors of each and any of them.
- D. Contractor shall be responsible for assuring that the agreement under which a Subcontractor performs a portion of the Work contains provisions whereby the Subcontractor waives all rights against Owner, Contractor, all individuals or entities identified in the Supplementary Conditions as insureds, the Engineer and its consultants, and the officers, directors, members, partners, employees, agents, consultants, and subcontractors of each and any of them, for all losses and damages caused by, arising out of, relating to, or resulting from any of the perils

or causes of loss covered by builder's risk insurance and any other property insurance applicable to the Work.

**6.07** *Receipt and Application of Property Insurance Proceeds*

- A. Any insured loss under the builder's risk and other policies of insurance required by Paragraph 6.05 will be adjusted and settled with the named insured that purchased the policy. Such named insured shall act as fiduciary for the other insureds and give notice to such other insureds that adjustment and settlement of a claim is in progress. Any other insured may state its position regarding a claim for insured loss in writing within 15 days after notice of such claim.
- B. Proceeds for such insured losses may be made payable by the insurer either jointly to multiple insureds, or to the named insured that purchased the policy in its own right and as fiduciary for other insureds, subject to the requirements of any applicable mortgage clause. A named insured receiving insurance proceeds under the builder's risk and other policies of insurance required by Paragraph 6.05 shall distribute such proceeds in accordance with such agreement as the parties in interest may reach, or as otherwise required under the dispute resolution provisions of this Contract or applicable Laws and Regulations.
- C. If no other special agreement is reached, the damaged Work shall be repaired or replaced, the money so received applied on account thereof, and the Work and the cost thereof covered by Change Order, if needed.

**ARTICLE 7—CONTRACTOR'S RESPONSIBILITIES**

**7.01** *Contractor's Means and Methods of Construction*

- A. Contractor shall be solely responsible for the means, methods, techniques, sequences, and procedures of construction.
- B. If the Contract Documents note, or Contractor determines, that professional engineering or other design services are needed to carry out Contractor's responsibilities for construction means, methods, techniques, sequences, and procedures, or for Site safety, then Contractor shall cause such services to be provided by a properly licensed design professional, at Contractor's expense. Such services are not Owner-delegated professional design services under this Contract, and neither Owner nor Engineer has any responsibility with respect to (1) Contractor's determination of the need for such services, (2) the qualifications or licensing of the design professionals retained or employed by Contractor, (3) the performance of such services, or (4) any errors, omissions, or defects in such services.

**7.02** *Supervision and Superintendence*

- A. Contractor shall supervise, inspect, and direct the Work competently and efficiently, devoting such attention thereto and applying such skills and expertise as may be necessary to perform the Work in accordance with the Contract Documents.
- B. At all times during the progress of the Work, Contractor shall assign a competent resident superintendent who will not be replaced without written notice to Owner and Engineer except under extraordinary circumstances.

### 7.03 *Labor; Working Hours*

- A. Contractor shall provide competent, suitably qualified personnel to survey and lay out the Work and perform construction as required by the Contract Documents. Contractor shall maintain good discipline and order at the Site.
- B. Contractor shall be fully responsible to Owner and Engineer for all acts and omissions of Contractor's employees; of Suppliers and Subcontractors, and their employees; and of any other individuals or entities performing or furnishing any of the Work, just as Contractor is responsible for Contractor's own acts and omissions.
- C. Except as otherwise required for the safety or protection of persons or the Work or property at the Site or adjacent thereto, and except as otherwise stated in the Contract Documents, all Work at the Site will be performed during regular working hours, Monday through Friday. Contractor will not perform Work on a Saturday, Sunday, or any legal holiday. Contractor may perform Work outside regular working hours or on Saturdays, Sundays, or legal holidays only with Owner's written consent.

### 7.04 *Services, Materials, and Equipment*

- A. Unless otherwise specified in the Contract Documents, Contractor shall provide and assume full responsibility for all services, materials, equipment, labor, transportation, construction equipment and machinery, tools, appliances, fuel, power, light, heat, telephone, water, sanitary facilities, temporary facilities, and all other facilities and incidentals necessary for the performance, testing, start up, and completion of the Work, whether or not such items are specifically called for in the Contract Documents.
- B. All materials and equipment incorporated into the Work must be new and of good quality, except as otherwise provided in the Contract Documents. All special warranties and guarantees required by the Specifications will expressly run to the benefit of Owner. If required by Engineer, Contractor shall furnish satisfactory evidence (including reports of required tests) as to the source, kind, and quality of materials and equipment.
- C. All materials and equipment must be stored, applied, installed, connected, erected, protected, used, cleaned, and conditioned in accordance with instructions of the applicable Supplier, except as otherwise may be provided in the Contract Documents.

### 7.05 *"Or Equals"*

- A. *Contractor's Request; Governing Criteria:* Whenever an item of equipment or material is specified or described in the Contract Documents by using the names of one or more proprietary items or specific Suppliers, the Contract Price has been based upon Contractor furnishing such item as specified. The specification or description of such an item is intended to establish the type, function, appearance, and quality required. Unless the specification or description contains or is followed by words reading that no like, equivalent, or "or equal" item is permitted, Contractor may request that Engineer authorize the use of other items of equipment or material, or items from other proposed Suppliers, under the circumstances described below.
  - 1. If Engineer in its sole discretion determines that an item of equipment or material proposed by Contractor is functionally equal to that named and sufficiently similar so that no change in related Work will be required, Engineer will deem it an "or equal" item. For

the purposes of this paragraph, a proposed item of equipment or material will be considered functionally equal to an item so named if:

- a. in the exercise of reasonable judgment Engineer determines that the proposed item:
    - 1) is at least equal in materials of construction, quality, durability, appearance, strength, and design characteristics;
    - 2) will reliably perform at least equally well the function and achieve the results imposed by the design concept of the completed Project as a functioning whole;
    - 3) has a proven record of performance and availability of responsive service; and
    - 4) is not objectionable to Owner.
  - b. Contractor certifies that, if the proposed item is approved and incorporated into the Work:
    - 1) there will be no increase in cost to the Owner or increase in Contract Times; and
    - 2) the item will conform substantially to the detailed requirements of the item named in the Contract Documents.
- B. *Contractor's Expense:* Contractor shall provide all data in support of any proposed "or equal" item at Contractor's expense.
- C. *Engineer's Evaluation and Determination:* Engineer will be allowed a reasonable time to evaluate each "or-equal" request. Engineer may require Contractor to furnish additional data about the proposed "or-equal" item. Engineer will be the sole judge of acceptability. No "or-equal" item will be ordered, furnished, installed, or utilized until Engineer's review is complete and Engineer determines that the proposed item is an "or-equal," which will be evidenced by an approved Shop Drawing or other written communication. Engineer will advise Contractor in writing of any negative determination.
- D. *Effect of Engineer's Determination:* Neither approval nor denial of an "or-equal" request will result in any change in Contract Price. The Engineer's denial of an "or-equal" request will be final and binding and may not be reversed through an appeal under any provision of the Contract.
- E. *Treatment as a Substitution Request:* If Engineer determines that an item of equipment or material proposed by Contractor does not qualify as an "or-equal" item, Contractor may request that Engineer consider the item a proposed substitute pursuant to Paragraph 7.06.

#### 7.06 Substitutes

- A. *Contractor's Request; Governing Criteria:* Unless the specification or description of an item of equipment or material required to be furnished under the Contract Documents contains or is followed by words reading that no substitution is permitted, Contractor may request that Engineer authorize the use of other items of equipment or material under the circumstances described below. To the extent possible such requests must be made before commencement of related construction at the Site.
1. Contractor shall submit sufficient information as provided below to allow Engineer to determine if the item of material or equipment proposed is functionally equivalent to that named and an acceptable substitute therefor. Engineer will not accept requests for

review of proposed substitute items of equipment or material from anyone other than Contractor.

2. The requirements for review by Engineer will be as set forth in Paragraph 7.06.B, as supplemented by the Specifications, and as Engineer may decide is appropriate under the circumstances.
3. Contractor shall make written application to Engineer for review of a proposed substitute item of equipment or material that Contractor seeks to furnish or use. The application:
  - a. will certify that the proposed substitute item will:
    - 1) perform adequately the functions and achieve the results called for by the general design;
    - 2) be similar in substance to the item specified; and
    - 3) be suited to the same use as the item specified.
  - b. will state:
    - 1) the extent, if any, to which the use of the proposed substitute item will necessitate a change in Contract Times;
    - 2) whether use of the proposed substitute item in the Work will require a change in any of the Contract Documents (or in the provisions of any other direct contract with Owner for other work on the Project) to adapt the design to the proposed substitute item; and
    - 3) whether incorporation or use of the proposed substitute item in connection with the Work is subject to payment of any license fee or royalty.
  - c. will identify:
    - 1) all variations of the proposed substitute item from the item specified; and
    - 2) available engineering, sales, maintenance, repair, and replacement services.
  - d. will contain an itemized estimate of all costs or credits that will result directly or indirectly from use of such substitute item, including but not limited to changes in Contract Price, shared savings, costs of redesign, and claims of other contractors affected by any resulting change.
- B. *Engineer's Evaluation and Determination:* Engineer will be allowed a reasonable time to evaluate each substitute request, and to obtain comments and direction from Owner. Engineer may require Contractor to furnish additional data about the proposed substitute item. Engineer will be the sole judge of acceptability. No substitute will be ordered, furnished, installed, or utilized until Engineer's review is complete and Engineer determines that the proposed item is an acceptable substitute. Engineer's determination will be evidenced by a Field Order or a proposed Change Order accounting for the substitution itself and all related impacts, including changes in Contract Price or Contract Times. Engineer will advise Contractor in writing of any negative determination.
- C. *Special Guarantee:* Owner may require Contractor to furnish at Contractor's expense a special performance guarantee or other surety with respect to any substitute.



- D. *Reimbursement of Engineer's Cost:* Engineer will record Engineer's costs in evaluating a substitute proposed or submitted by Contractor. Whether or not Engineer approves a substitute so proposed or submitted by Contractor, Contractor shall reimburse Owner for the reasonable charges of Engineer for evaluating each such proposed substitute. Contractor shall also reimburse Owner for the reasonable charges of Engineer for making changes in the Contract Documents (or in the provisions of any other direct contract with Owner) resulting from the acceptance of each proposed substitute.
- E. *Contractor's Expense:* Contractor shall provide all data in support of any proposed substitute at Contractor's expense.
- F. *Effect of Engineer's Determination:* If Engineer approves the substitution request, Contractor shall execute the proposed Change Order and proceed with the substitution. The Engineer's denial of a substitution request will be final and binding and may not be reversed through an appeal under any provision of the Contract. Contractor may challenge the scope of reimbursement costs imposed under Paragraph 7.06.D, by timely submittal of a Change Proposal.

#### 7.07 *Concerning Subcontractors and Suppliers*

- A. Contractor may retain Subcontractors and Suppliers for the performance of parts of the Work. Such Subcontractors and Suppliers must be acceptable to Owner. The Contractor's retention of a Subcontractor or Supplier for the performance of parts of the Work will not relieve Contractor's obligation to Owner to perform and complete the Work in accordance with the Contract Documents.
- B. Contractor shall retain specific Subcontractors and Suppliers for the performance of designated parts of the Work if required by the Contract to do so.
- C. Subsequent to the submittal of Contractor's Bid or final negotiation of the terms of the Contract, Owner may not require Contractor to retain any Subcontractor or Supplier to furnish or perform any of the Work against which Contractor has reasonable objection.
- D. Prior to entry into any binding subcontract or purchase order, Contractor shall submit to Owner the identity of the proposed Subcontractor or Supplier (unless Owner has already deemed such proposed Subcontractor or Supplier acceptable during the bidding process or otherwise). Such proposed Subcontractor or Supplier shall be deemed acceptable to Owner unless Owner raises a substantive, reasonable objection within 10 days.
- E. Owner may require the replacement of any Subcontractor or Supplier. Owner also may require Contractor to retain specific replacements; provided, however, that Owner may not require a replacement to which Contractor has a reasonable objection. If Contractor has submitted the identity of certain Subcontractors or Suppliers for acceptance by Owner, and Owner has accepted it (either in writing or by failing to make written objection thereto), then Owner may subsequently revoke the acceptance of any such Subcontractor or Supplier so identified solely on the basis of substantive, reasonable objection after due investigation. Contractor shall submit an acceptable replacement for the rejected Subcontractor or Supplier.
- F. If Owner requires the replacement of any Subcontractor or Supplier retained by Contractor to perform any part of the Work, then Contractor shall be entitled to an adjustment in Contract Price or Contract Times, with respect to the replacement; and Contractor shall

initiate a Change Proposal for such adjustment within 30 days of Owner's requirement of replacement.

- G. No acceptance by Owner of any such Subcontractor or Supplier, whether initially or as a replacement, will constitute a waiver of the right of Owner to the completion of the Work in accordance with the Contract Documents.
- H. On a monthly basis, Contractor shall submit to Engineer a complete list of all Subcontractors and Suppliers having a direct contract with Contractor, and of all other Subcontractors and Suppliers known to Contractor at the time of submittal.
- I. Contractor shall be solely responsible for scheduling and coordinating the work of Subcontractors and Suppliers.
- J. The divisions and sections of the Specifications and the identifications of any Drawings do not control Contractor in dividing the Work among Subcontractors or Suppliers, or in delineating the Work to be performed by any specific trade.
- K. All Work performed for Contractor by a Subcontractor or Supplier must be pursuant to an appropriate contractual agreement that specifically binds the Subcontractor or Supplier to the applicable terms and conditions of the Contract for the benefit of Owner and Engineer.
- L. Owner may furnish to any Subcontractor or Supplier, to the extent practicable, information about amounts paid to Contractor for Work performed for Contractor by the Subcontractor or Supplier.
- M. Contractor shall restrict all Subcontractors and Suppliers from communicating with Engineer or Owner, except through Contractor or in case of an emergency, or as otherwise expressly allowed in this Contract.
- N. Nothing in the Contract Documents:
  - shall create for the benefit of any such Subcontractor, Supplier, or other individual or entity any contractual relationship between Owner or Engineer and any such Subcontractor, Supplier, or other individual or entity; nor
  - shall create any obligation on the part of Owner or Engineer to pay or to see to the payment of any money due any such Subcontractor, Supplier, or other individual or entity except as may otherwise be required by Laws and Regulations.

7.08 *Patent Fees and Royalties*

- A. Contractor shall pay all license fees and royalties and assume all costs incident to the use in the performance of the Work or the incorporation in the Work of any invention, design, process, product, or device which is the subject of patent rights or copyrights held by others. If an invention, design, process, product, or device is specified in the Contract Documents for use in the performance of the Work and if, to the actual knowledge of Owner or Engineer, its use is subject to patent rights or copyrights calling for the payment of any license fee or royalty to others, the existence of such rights will be disclosed in the Contract Documents.
- B. To the fullest extent permitted by Laws and Regulations, Owner shall indemnify and hold harmless Contractor, and its officers, directors, members, partners, employees, agents, consultants, and subcontractors, from and against all claims, costs, losses, and damages (including but not limited to all fees and charges of engineers, architects, attorneys, and other professionals, and all court or arbitration or other dispute resolution costs) arising out of or

relating to any infringement of patent rights or copyrights incident to the use in the performance of the Work or resulting from the incorporation in the Work of any invention, design, process, product, or device specified in the Contract Documents, but not identified as being subject to payment of any license fee or royalty to others required by patent rights or copyrights.

- C. To the fullest extent permitted by Laws and Regulations, Contractor shall indemnify and hold harmless Owner and Engineer, and the officers, directors, members, partners, employees, agents, consultants and subcontractors of each and any of them, from and against all claims, costs, losses, and damages (including but not limited to all fees and charges of engineers, architects, attorneys, and other professionals and all court or arbitration or other dispute resolution costs) arising out of or relating to any infringement of patent rights or copyrights incident to the use in the performance of the Work or resulting from the incorporation in the Work of any invention, design, process, product, or device not specified in the Contract Documents.

#### 7.09 *Permits*

- A. Unless otherwise provided in the Contract Documents, Contractor shall obtain and pay for all construction permits, licenses, and certificates of occupancy. Owner shall assist Contractor, when necessary, in obtaining such permits and licenses. Contractor shall pay all governmental charges and inspection fees necessary for the prosecution of the Work which are applicable at the time of the submission of Contractor's Bid (or when Contractor became bound under a negotiated contract). Owner shall pay all charges of utility owners for connections for providing permanent service to the Work.

#### 7.10 *Taxes*

- A. Contractor shall pay all sales, consumer, use, and other similar taxes required to be paid by Contractor in accordance with the Laws and Regulations of the place of the Project which are applicable during the performance of the Work.

#### 7.11 *Laws and Regulations*

- A. Contractor shall give all notices required by and shall comply with all Laws and Regulations applicable to the performance of the Work. Neither Owner nor Engineer shall be responsible for monitoring Contractor's compliance with any Laws or Regulations.
- B. If Contractor performs any Work or takes any other action knowing or having reason to know that it is contrary to Laws or Regulations, Contractor shall bear all resulting costs and losses, and shall indemnify and hold harmless Owner and Engineer, and the officers, directors, members, partners, employees, agents, consultants, and subcontractors of each and any of them, from and against all claims, costs, losses, and damages (including but not limited to all fees and charges of engineers, architects, attorneys, and other professionals and all court or arbitration or other dispute resolution costs) arising out of or relating to such Work or other action. It is not Contractor's responsibility to make certain that the Work described in the Contract Documents is in accordance with Laws and Regulations, but this does not relieve Contractor of its obligations under Paragraph 3.03.
- C. Owner or Contractor may give written notice to the other party of any changes after the submission of Contractor's Bid (or after the date when Contractor became bound under a negotiated contract) in Laws or Regulations having an effect on the cost or time of performance of the Work, including but not limited to changes in Laws or Regulations having

an effect on procuring permits and on sales, use, value-added, consumption, and other similar taxes. If Owner and Contractor are unable to agree on entitlement to or on the amount or extent, if any, of any adjustment in Contract Price or Contract Times resulting from such changes, then within 30 days of such written notice Contractor may submit a Change Proposal, or Owner may initiate a Claim.

#### 7.12 *Record Documents*

- A. Contractor shall maintain in a safe place at the Site one printed record copy of all Drawings, Specifications, Addenda, Change Orders, Work Change Directives, Field Orders, written interpretations and clarifications, and approved Shop Drawings. Contractor shall keep such record documents in good order and annotate them to show changes made during construction. These record documents, together with all approved Samples, will be available to Engineer for reference. Upon completion of the Work, Contractor shall deliver these record documents to Engineer.

#### 7.13 *Safety and Protection*

- A. Contractor shall be solely responsible for initiating, maintaining, and supervising all safety precautions and programs in connection with the Work. Such responsibility does not relieve Subcontractors of their responsibility for the safety of persons or property in the performance of their work, nor for compliance with applicable safety Laws and Regulations.
- B. Contractor shall designate a qualified and experienced safety representative whose duties and responsibilities are the prevention of Work-related accidents and the maintenance and supervision of safety precautions and programs.
- C. Contractor shall take all necessary precautions for the safety of, and shall provide the necessary protection to prevent damage, injury, or loss to:
  - 1. all persons on the Site or who may be affected by the Work;
  - 2. all the Work and materials and equipment to be incorporated therein, whether in storage on or off the Site; and
  - 3. other property at the Site or adjacent thereto, including trees, shrubs, lawns, walks, pavements, roadways, structures, other work in progress, utilities, and Underground Facilities not designated for removal, relocation, or replacement in the course of construction.
- D. All damage, injury, or loss to any property referred to in Paragraph 7.13.C.2 or 7.13.C.3 caused, directly or indirectly, in whole or in part, by Contractor, any Subcontractor, Supplier, or any other individual or entity directly or indirectly employed by any of them to perform any of the Work, or anyone for whose acts any of them may be liable, shall be remedied by Contractor at its expense (except damage or loss attributable to the fault of Drawings or Specifications or to the acts or omissions of Owner or Engineer or anyone employed by any of them, or anyone for whose acts any of them may be liable, and not attributable, directly or indirectly, in whole or in part, to the fault or negligence of Contractor or any Subcontractor, Supplier, or other individual or entity directly or indirectly employed by any of them).
- E. Contractor shall comply with all applicable Laws and Regulations relating to the safety of persons or property, or to the protection of persons or property from damage, injury, or loss; and shall erect and maintain all necessary safeguards for such safety and protection.

- F. Contractor shall notify Owner; the owners of adjacent property; the owners of Underground Facilities and other utilities (if the identity of such owners is known to Contractor); and other contractors and utility owners performing work at or adjacent to the Site, in writing, when Contractor knows that prosecution of the Work may affect them, and shall cooperate with them in the protection, removal, relocation, and replacement of their property or work in progress.
- G. Contractor shall comply with the applicable requirements of Owner's safety programs, if any. Any Owner's safety programs that are applicable to the Work are identified or included in the Supplementary Conditions or Specifications.
- H. Contractor shall inform Owner and Engineer of the specific requirements of Contractor's safety program with which Owner's and Engineer's employees and representatives must comply while at the Site.
- I. Contractor's duties and responsibilities for safety and protection will continue until all the Work is completed, Engineer has issued a written notice to Owner and Contractor in accordance with Paragraph 15.06.C that the Work is acceptable, and Contractor has left the Site (except as otherwise expressly provided in connection with Substantial Completion).
- J. Contractor's duties and responsibilities for safety and protection will resume whenever Contractor or any Subcontractor or Supplier returns to the Site to fulfill warranty or correction obligations, or to conduct other tasks arising from the Contract Documents.

7.14 *Hazard Communication Programs*

- A. Contractor shall be responsible for coordinating any exchange of safety data sheets (formerly known as material safety data sheets) or other hazard communication information required to be made available to or exchanged between or among employers at the Site in accordance with Laws or Regulations.

7.15 *Emergencies*

- A. In emergencies affecting the safety or protection of persons or the Work or property at the Site or adjacent thereto, Contractor is obligated to act to prevent damage, injury, or loss. Contractor shall give Engineer prompt written notice if Contractor believes that any significant changes in the Work or variations from the Contract Documents have been caused by an emergency or are required as a result of Contractor's response to an emergency. If Engineer determines that a change in the Contract Documents is required because of an emergency or Contractor's response, a Work Change Directive or Change Order will be issued.

7.16 *Submittals*

A. *Shop Drawing and Sample Requirements*

1. Before submitting a Shop Drawing or Sample, Contractor shall:
  - a. review and coordinate the Shop Drawing or Sample with other Shop Drawings and Samples and with the requirements of the Work and the Contract Documents;
  - b. determine and verify:
    - 1) all field measurements, quantities, dimensions, specified performance and design criteria, installation requirements, materials, catalog numbers, and similar information with respect to the Submittal;

- 2) the suitability of all materials and equipment offered with respect to the indicated application, fabrication, shipping, handling, storage, assembly, and installation pertaining to the performance of the Work; and
      - 3) all information relative to Contractor's responsibilities for means, methods, techniques, sequences, and procedures of construction, and safety precautions and programs incident thereto;
    - c. confirm that the Submittal is complete with respect to all related data included in the Submittal.
  2. Each Shop Drawing or Sample must bear a stamp or specific written certification that Contractor has satisfied Contractor's obligations under the Contract Documents with respect to Contractor's review of that Submittal, and that Contractor approves the Submittal.
  3. With each Shop Drawing or Sample, Contractor shall give Engineer specific written notice of any variations that the Submittal may have from the requirements of the Contract Documents. This notice must be set forth in a written communication separate from the Submittal; and, in addition, in the case of a Shop Drawing by a specific notation made on the Shop Drawing itself.
- B. *Submittal Procedures for Shop Drawings and Samples:* Contractor shall label and submit Shop Drawings and Samples to Engineer for review and approval in accordance with the accepted Schedule of Submittals.
  1. *Shop Drawings*
    - a. Contractor shall submit the number of copies required in the Specifications.
    - b. Data shown on the Shop Drawings must be complete with respect to quantities, dimensions, specified performance and design criteria, materials, and similar data to show Engineer the services, materials, and equipment Contractor proposes to provide, and to enable Engineer to review the information for the limited purposes required by Paragraph 7.16.C.
  2. *Samples*
    - a. Contractor shall submit the number of Samples required in the Specifications.
    - b. Contractor shall clearly identify each Sample as to material, Supplier, pertinent data such as catalog numbers, the use for which intended and other data as Engineer may require to enable Engineer to review the Submittal for the limited purposes required by Paragraph 7.16.C.
  3. Where a Shop Drawing or Sample is required by the Contract Documents or the Schedule of Submittals, any related Work performed prior to Engineer's review and approval of the pertinent submittal will be at the sole expense and responsibility of Contractor.
- C. *Engineer's Review of Shop Drawings and Samples*
  1. Engineer will provide timely review of Shop Drawings and Samples in accordance with the accepted Schedule of Submittals. Engineer's review and approval will be only to determine if the items covered by the Submittals will, after installation or incorporation in the Work, comply with the requirements of the Contract Documents, and be

compatible with the design concept of the completed Project as a functioning whole as indicated by the Contract Documents.

2. Engineer's review and approval will not extend to means, methods, techniques, sequences, or procedures of construction, or to safety precautions or programs incident thereto.
3. Engineer's review and approval of a separate item as such will not indicate approval of the assembly in which the item functions.
4. Engineer's review and approval of a Shop Drawing or Sample will not relieve Contractor from responsibility for any variation from the requirements of the Contract Documents unless Contractor has complied with the requirements of Paragraph 7.16.A.3 and Engineer has given written approval of each such variation by specific written notation thereof incorporated in or accompanying the Shop Drawing or Sample. Engineer will document any such approved variation from the requirements of the Contract Documents in a Field Order or other appropriate Contract modification.
5. Engineer's review and approval of a Shop Drawing or Sample will not relieve Contractor from responsibility for complying with the requirements of Paragraphs 7.16.A and B.
6. Engineer's review and approval of a Shop Drawing or Sample, or of a variation from the requirements of the Contract Documents, will not, under any circumstances, change the Contract Times or Contract Price, unless such changes are included in a Change Order.
7. Neither Engineer's receipt, review, acceptance, or approval of a Shop Drawing or Sample will result in such item becoming a Contract Document.
8. Contractor shall perform the Work in compliance with the requirements and commitments set forth in approved Shop Drawings and Samples, subject to the provisions of Paragraph 7.16.C.4.

*D. Resubmittal Procedures for Shop Drawings and Samples*

1. Contractor shall make corrections required by Engineer and shall return the required number of corrected copies of Shop Drawings and submit, as required, new Samples for review and approval. Contractor shall direct specific attention in writing to revisions other than the corrections called for by Engineer on previous Submittals.
2. Contractor shall furnish required Shop Drawing and Sample submittals with sufficient information and accuracy to obtain required approval of an item with no more than two resubmittals. Engineer will record Engineer's time for reviewing a third or subsequent resubmittal of a Shop Drawing or Sample, and Contractor shall be responsible for Engineer's charges to Owner for such time. Owner may impose a set-off against payments due Contractor to secure reimbursement for such charges.
3. If Contractor requests a change of a previously approved Shop Drawing or Sample, Contractor shall be responsible for Engineer's charges to Owner for its review time, and Owner may impose a set-off against payments due Contractor to secure reimbursement for such charges, unless the need for such change is beyond the control of Contractor.

- E. *Submittals Other than Shop Drawings, Samples, and Owner-Delegated Designs*
1. The following provisions apply to all Submittals other than Shop Drawings, Samples, and Owner-delegated designs:
    - a. Contractor shall submit all such Submittals to the Engineer in accordance with the Schedule of Submittals and pursuant to the applicable terms of the Contract Documents.
    - b. Engineer will provide timely review of all such Submittals in accordance with the Schedule of Submittals and return such Submittals with a notation of either Accepted or Not Accepted. Any such Submittal that is not returned within the time established in the Schedule of Submittals will be deemed accepted.
    - c. Engineer's review will be only to determine if the Submittal is acceptable under the requirements of the Contract Documents as to general form and content of the Submittal.
    - d. If any such Submittal is not accepted, Contractor shall confer with Engineer regarding the reason for the non-acceptance and resubmit an acceptable document.
  2. Procedures for the submittal and acceptance of the Progress Schedule, the Schedule of Submittals, and the Schedule of Values are set forth in Paragraphs 2.03, 2.04, and 2.05.
- F. Owner-delegated Designs: Submittals pursuant to Owner-delegated designs are governed by the provisions of Paragraph 7.19.

7.17 *Contractor's General Warranty and Guarantee*

- A. Contractor warrants and guarantees to Owner that all Work will be in accordance with the Contract Documents and will not be defective. Engineer is entitled to rely on Contractor's warranty and guarantee.
- B. Owner's rights under this warranty and guarantee are in addition to, and are not limited by, Owner's rights under the correction period provisions of Paragraph 15.08. The time in which Owner may enforce its warranty and guarantee rights under this Paragraph 7.17 is limited only by applicable Laws and Regulations restricting actions to enforce such rights; provided, however, that after the end of the correction period under Paragraph 15.08:
1. Owner shall give Contractor written notice of any defective Work within 60 days of the discovery that such Work is defective; and
  2. Such notice will be deemed the start of an event giving rise to a Claim under Paragraph 12.01.B, such that any related Claim must be brought within 30 days of the notice.
- C. Contractor's warranty and guarantee hereunder excludes defects or damage caused by:
1. abuse, or improper modification, maintenance, or operation, by persons other than Contractor, Subcontractors, Suppliers, or any other individual or entity for whom Contractor is responsible; or
  2. normal wear and tear under normal usage.
- D. Contractor's obligation to perform and complete the Work in accordance with the Contract Documents is absolute. None of the following will constitute an acceptance of Work that is



not in accordance with the Contract Documents, a release of Contractor's obligation to perform the Work in accordance with the Contract Documents, or a release of Owner's warranty and guarantee rights under this Paragraph 7.17:

1. Observations by Engineer;
  2. Recommendation by Engineer or payment by Owner of any progress or final payment;
  3. The issuance of a certificate of Substantial Completion by Engineer or any payment related thereto by Owner;
  4. Use or occupancy of the Work or any part thereof by Owner;
  5. Any review and approval of a Shop Drawing or Sample submittal;
  6. The issuance of a notice of acceptability by Engineer;
  7. The end of the correction period established in Paragraph 15.08;
  8. Any inspection, test, or approval by others; or
  9. Any correction of defective Work by Owner.
- E. If the Contract requires the Contractor to accept the assignment of a contract entered into by Owner, then the specific warranties, guarantees, and correction obligations contained in the assigned contract will govern with respect to Contractor's performance obligations to Owner for the Work described in the assigned contract.

#### 7.18 *Indemnification*

- A. To the fullest extent permitted by Laws and Regulations, and in addition to any other obligations of Contractor under the Contract or otherwise, Contractor shall indemnify and hold harmless Owner and Engineer, and the officers, directors, members, partners, employees, agents, consultants and subcontractors of each and any of them, from losses, damages, costs, and judgments (including but not limited to all fees and charges of engineers, architects, attorneys, and other professionals, and all court or arbitration or other dispute resolution costs) arising from third-party claims or actions relating to or resulting from the performance or furnishing of the Work, provided that any such claim, action, loss, cost, judgment or damage is attributable to bodily injury, sickness, disease, or death, or to damage to or destruction of tangible property (other than the Work itself), including the loss of use resulting therefrom, but only to the extent caused by any negligent act or omission of Contractor, any Subcontractor, any Supplier, or any individual or entity directly or indirectly employed by any of them to perform any of the Work, or anyone for whose acts any of them may be liable.
- B. In any and all claims against Owner or Engineer, or any of their officers, directors, members, partners, employees, agents, consultants, or subcontractors, by any employee (or the survivor or personal representative of such employee) of Contractor, any Subcontractor, any Supplier, or any individual or entity directly or indirectly employed by any of them to perform any of the Work, or anyone for whose acts any of them may be liable, the indemnification obligation under Paragraph 7.18.A will not be limited in any way by any limitation on the amount or type of damages, compensation, or benefits payable by or for Contractor or any such Subcontractor, Supplier, or other individual or entity under workers' compensation acts, disability benefit acts, or other employee benefit acts.

#### 7.19 *Delegation of Professional Design Services*

- A. Owner may require Contractor to provide professional design services for a portion of the Work by express delegation in the Contract Documents. Such delegation will specify the performance and design criteria that such services must satisfy, and the Submittals that Contractor must furnish to Engineer with respect to the Owner-delegated design.
- B. Contractor shall cause such Owner-delegated professional design services to be provided pursuant to the professional standard of care by a properly licensed design professional, whose signature and seal must appear on all drawings, calculations, specifications, certifications, and Submittals prepared by such design professional. Such design professional must issue all certifications of design required by Laws and Regulations.
- C. If a Shop Drawing or other Submittal related to the Owner-delegated design is prepared by Contractor, a Subcontractor, or others for submittal to Engineer, then such Shop Drawing or other Submittal must bear the written approval of Contractor's design professional when submitted by Contractor to Engineer.
- D. Owner and Engineer shall be entitled to rely upon the adequacy, accuracy, and completeness of the services, certifications, and approvals performed or provided by the design professionals retained or employed by Contractor under an Owner-delegated design, subject to the professional standard of care and the performance and design criteria stated in the Contract Documents.
- E. Pursuant to this Paragraph 7.19, Engineer's review, approval, and other determinations regarding design drawings, calculations, specifications, certifications, and other Submittals furnished by Contractor pursuant to an Owner-delegated design will be only for the following limited purposes:
  - 1. Checking for conformance with the requirements of this Paragraph 7.19;
  - 2. Confirming that Contractor (through its design professionals) has used the performance and design criteria specified in the Contract Documents; and
  - 3. Establishing that the design furnished by Contractor is consistent with the design concept expressed in the Contract Documents.
- F. Contractor shall not be responsible for the adequacy of performance or design criteria specified by Owner or Engineer.
- G. Contractor is not required to provide professional services in violation of applicable Laws and Regulations.

### **ARTICLE 8—OTHER WORK AT THE SITE**

#### 8.01 *Other Work*

- A. In addition to and apart from the Work under the Contract Documents, the Owner may perform other work at or adjacent to the Site. Such other work may be performed by Owner's employees, or through contracts between the Owner and third parties. Owner may also arrange to have third-party utility owners perform work on their utilities and facilities at or adjacent to the Site.

- B. If Owner performs other work at or adjacent to the Site with Owner's employees, or through contracts for such other work, then Owner shall give Contractor written notice thereof prior to starting any such other work. If Owner has advance information regarding the start of any third-party utility work that Owner has arranged to take place at or adjacent to the Site, Owner shall provide such information to Contractor.
- C. Contractor shall afford proper and safe access to the Site to each contractor that performs such other work, each utility owner performing other work, and Owner, if Owner is performing other work with Owner's employees, and provide a reasonable opportunity for the introduction and storage of materials and equipment and the execution of such other work.
- D. Contractor shall do all cutting, fitting, and patching of the Work that may be required to properly connect or otherwise make its several parts come together and properly integrate with such other work. Contractor shall not endanger any work of others by cutting, excavating, or otherwise altering such work; provided, however, that Contractor may cut or alter others' work with the written consent of Engineer and the others whose work will be affected.
- E. If the proper execution or results of any part of Contractor's Work depends upon work performed by others, Contractor shall inspect such other work and promptly report to Engineer in writing any delays, defects, or deficiencies in such other work that render it unavailable or unsuitable for the proper execution and results of Contractor's Work. Contractor's failure to so report will constitute an acceptance of such other work as fit and proper for integration with Contractor's Work except for latent defects and deficiencies in such other work.
- F. The provisions of this article are not applicable to work that is performed by third-party utilities or other third-party entities without a contract with Owner, or that is performed without having been arranged by Owner. If such work occurs, then any related delay, disruption, or interference incurred by Contractor is governed by the provisions of Paragraph 4.05.C.3.

#### 8.02 *Coordination*

- A. If Owner intends to contract with others for the performance of other work at or adjacent to the Site, to perform other work at or adjacent to the Site with Owner's employees, or to arrange to have utility owners perform work at or adjacent to the Site, the following will be set forth in the Supplementary Conditions, Section 1 of the Project Manual, or provided to Contractor prior to the start of any such other work:
  - 1. The identity of the individual or entity that will have authority and responsibility for coordination of the activities among the various contractors;
  - 2. An itemization of the specific matters to be covered by such authority and responsibility; and
  - 3. The extent of such authority and responsibilities.
- B. Unless otherwise provided in Section 1 of the Project Manual, Owner shall have sole authority and responsibility for such coordination.

### 8.03 *Legal Relationships*

- A. If, in the course of performing other work for Owner at or adjacent to the Site, the Owner's employees, any other contractor working for Owner, or any utility owner that Owner has arranged to perform work, causes damage to the Work or to the property of Contractor or its Subcontractors, or delays, disrupts, interferes with, or increases the scope or cost of the performance of the Work, through actions or inaction, then Contractor shall be entitled to an equitable adjustment in the Contract Price or the Contract Times. Contractor must submit any Change Proposal seeking an equitable adjustment in the Contract Price or the Contract Times under this paragraph within 30 days of the damaging, delaying, disrupting, or interfering event. The entitlement to, and extent of, any such equitable adjustment will take into account information (if any) regarding such other work that was provided to Contractor in the Contract Documents prior to the submittal of the Bid or the final negotiation of the terms of the Contract, and any remedies available to Contractor under Laws or Regulations concerning utility action or inaction. When applicable, any such equitable adjustment in Contract Price will be conditioned on Contractor assigning to Owner all Contractor's rights against such other contractor or utility owner with respect to the damage, delay, disruption, or interference that is the subject of the adjustment. Contractor's entitlement to an adjustment of the Contract Times or Contract Price is subject to the provisions of Paragraphs 4.05.D and 4.05.E.
- B. Contractor shall take reasonable and customary measures to avoid damaging, delaying, disrupting, or interfering with the work of Owner, any other contractor, or any utility owner performing other work at or adjacent to the Site.
1. If Contractor fails to take such measures and as a result damages, delays, disrupts, or interferes with the work of any such other contractor or utility owner, then Owner may impose a set-off against payments due Contractor, and assign to such other contractor or utility owner the Owner's contractual rights against Contractor with respect to the breach of the obligations set forth in this Paragraph 8.03.B.
  2. When Owner is performing other work at or adjacent to the Site with Owner's employees, Contractor shall be liable to Owner for damage to such other work, and for the reasonable direct delay, disruption, and interference costs incurred by Owner as a result of Contractor's failure to take reasonable and customary measures with respect to Owner's other work. In response to such damage, delay, disruption, or interference, Owner may impose a set-off against payments due Contractor.
- C. If Contractor damages, delays, disrupts, or interferes with the work of any other contractor, or any utility owner performing other work at or adjacent to the Site, through Contractor's failure to take reasonable and customary measures to avoid such impacts, or if any claim arising out of Contractor's actions, inactions, or negligence in performance of the Work at or adjacent to the Site is made by any such other contractor or utility owner against Contractor, Owner, or Engineer, then Contractor shall (1) promptly attempt to settle the claim as to all parties through negotiations with such other contractor or utility owner, or otherwise resolve the claim by arbitration or other dispute resolution proceeding or at law, and (2) indemnify and hold harmless Owner and Engineer, and the officers, directors, members, partners, employees, agents, consultants and subcontractors of each and any of them from and against any such claims, and against all costs, losses, and damages (including but not limited to all fees and charges of engineers, architects, attorneys, and other professionals and all court or

arbitration or other dispute resolution costs) arising out of or relating to such damage, delay, disruption, or interference.

## **ARTICLE 9—OWNER’S RESPONSIBILITIES**

### **9.01 *Communications to Contractor***

A. Except as otherwise provided in these General Conditions, Owner shall issue all communications to Contractor through Engineer.

### **9.02 *Replacement of Engineer***

A. Owner may at its discretion appoint an engineer to replace Engineer, provided Contractor makes no reasonable objection to the replacement engineer. The replacement engineer’s status under the Contract Documents will be that of the former Engineer.

### **9.03 *Furnish Data***

A. Owner shall promptly furnish the data required of Owner under the Contract Documents.

### **9.04 *Pay When Due***

A. Owner shall make payments to Contractor in accordance with Paragraph 15.01 D.

### **9.05 *Lands and Easements; Reports, Tests, and Drawings***

- A. Owner’s duties with respect to providing lands and easements are set forth in Paragraph 5.01.
- B. Owner’s duties with respect to providing engineering surveys to establish reference points are set forth in Paragraph 4.03.
- C. Article 5 refers to Owner’s identifying and making available to Contractor copies of reports of explorations and tests of conditions at the Site, and drawings of physical conditions relating to existing surface or subsurface structures at the Site.

### **9.06 *Insurance***

A. Owner’s responsibilities, if any, with respect to purchasing and maintaining liability and property insurance are set forth in Article 6.

### **9.07 *Change Orders***

A. Owner’s responsibilities with respect to Change Orders are set forth in Article 11.

### **9.08 *Inspections, Tests, and Approvals***

A. Owner’s responsibility with respect to certain inspections, tests, and approvals is set forth in Paragraph 14.02.B.

### **9.09 *Limitations on Owner’s Responsibilities***

A. The Owner shall not supervise, direct, or have control or authority over, nor be responsible for, Contractor’s means, methods, techniques, sequences, or procedures of construction, or the safety precautions and programs incident thereto, or for any failure of Contractor to comply with Laws and Regulations applicable to the performance of the Work. Owner will not be responsible for Contractor’s failure to perform the Work in accordance with the Contract Documents.

9.10 *Undisclosed Hazardous Environmental Condition*

- A. Owner's responsibility in respect to an undisclosed Hazardous Environmental Condition is set forth in Paragraph 5.06.

9.11 *Evidence of Financial Arrangements*

- A. Upon request of Contractor, Owner shall furnish Contractor reasonable evidence that financial arrangements have been made to satisfy Owner's obligations under the Contract (including obligations under proposed changes in the Work).

9.12 *Safety Programs*

- A. While at the Site, Owner's employees and representatives shall comply with the specific applicable requirements of Contractor's safety programs of which Owner has been informed.
- B. Owner shall furnish copies of any applicable Owner safety programs to Contractor.

**ARTICLE 10—ENGINEER'S STATUS DURING CONSTRUCTION**

10.01 *Owner's Representative*

- A. Engineer will be Owner's representative during the construction period. The duties and responsibilities and the limitations of authority of Engineer as Owner's representative during construction are set forth in the Contract.

10.02 *Visits to Site*

- A. Engineer will make visits to the Site at intervals appropriate to the various stages of construction as Engineer deems necessary in order to observe, as an experienced and qualified design professional, the progress that has been made and the quality of the various aspects of Contractor's executed Work. Based on information obtained during such visits and observations, Engineer, for the benefit of Owner, will determine, in general, if the Work is proceeding in accordance with the Contract Documents. Engineer will not be required to make exhaustive or continuous inspections on the Site to check the quality or quantity of the Work. Engineer's efforts will be directed toward providing for Owner a greater degree of confidence that the completed Work will conform generally to the Contract Documents. On the basis of such visits and observations, Engineer will keep Owner informed of the progress of the Work and will endeavor to guard Owner against defective Work.
- B. Engineer's visits and observations are subject to all the limitations on Engineer's authority and responsibility set forth in Paragraph 10.07. Particularly, but without limitation, during or as a result of Engineer's visits or observations of Contractor's Work, Engineer will not supervise, direct, control, or have authority over or be responsible for Contractor's means, methods, techniques, sequences, or procedures of construction, or the safety precautions and programs incident thereto, or for any failure of Contractor to comply with Laws and Regulations applicable to the performance of the Work.

10.03 *Resident Project Representative*

- A. If Owner and Engineer have agreed that Engineer will furnish a Resident Project Representative to represent Engineer at the Site and assist Engineer in observing the progress and quality of the Work, then the authority and responsibilities of any such Resident Project Representative will be as provided in the Supplementary Conditions, and limitations on the

responsibilities thereof will be as provided in the Supplementary Conditions and in Paragraph 10.07.

- B. If Owner designates an individual or entity who is not Engineer's consultant, agent, or employee to represent Owner at the Site, then the responsibilities and authority of such individual or entity will be as provided in the Supplementary Conditions.

10.04 *Engineer's Authority*

- A. Engineer has the authority to reject Work in accordance with Article 14.
- B. Engineer's authority as to Submittals is set forth in Paragraph 7.16.
- C. Engineer's authority as to design drawings, calculations, specifications, certifications and other Submittals from Contractor in response to Owner's delegation (if any) to Contractor of professional design services, is set forth in Paragraph 7.19.
- D. Engineer's authority as to changes in the Work is set forth in Article 11.
- E. Engineer's authority as to Applications for Payment is set forth in Article 15.

10.05 *Determinations for Unit Price Work*

- A. Engineer will determine the actual quantities and classifications of Unit Price Work performed by Contractor as set forth in Paragraph 13.03.

10.06 *Decisions on Requirements of Contract Documents and Acceptability of Work*

- A. Engineer will render decisions regarding the requirements of the Contract Documents, and judge the acceptability of the Work, pursuant to the specific procedures set forth herein for initial interpretations, Change Proposals, and acceptance of the Work. In rendering such decisions and judgments, Engineer will not show partiality to Owner or Contractor, and will not be liable to Owner, Contractor, or others in connection with any proceedings, interpretations, decisions, or judgments conducted or rendered in good faith.

10.07 *Limitations on Engineer's Authority and Responsibilities*

- A. Neither Engineer's authority or responsibility under this Article 10 or under any other provision of the Contract, nor any decision made by Engineer in good faith either to exercise or not exercise such authority or responsibility or the undertaking, exercise, or performance of any authority or responsibility by Engineer, will create, impose, or give rise to any duty in contract, tort, or otherwise owed by Engineer to Contractor, any Subcontractor, any Supplier, any other individual or entity, or to any surety for or employee or agent of any of them.
- B. Engineer will not supervise, direct, control, or have authority over or be responsible for Contractor's means, methods, techniques, sequences, or procedures of construction, or the safety precautions and programs incident thereto, or for any failure of Contractor to comply with Laws and Regulations applicable to the performance of the Work. Engineer will not be responsible for Contractor's failure to perform the Work in accordance with the Contract Documents.
- C. Engineer will not be responsible for the acts or omissions of Contractor or of any Subcontractor, any Supplier, or of any other individual or entity performing any of the Work.
- D. Engineer's review of the final Application for Payment and accompanying documentation, and all maintenance and operating instructions, schedules, guarantees, bonds, certificates of

inspection, tests and approvals, and other documentation required to be delivered by Contractor under Paragraph 15.06.A, will only be to determine generally that their content complies with the requirements of, and in the case of certificates of inspections, tests, and approvals, that the results certified indicate compliance with the Contract Documents.

- E. The limitations upon authority and responsibility set forth in this Paragraph 10.07 also apply to the Resident Project Representative, if any.

#### 10.08 *Compliance with Safety Program*

- A. While at the Site, Engineer's employees and representatives will comply with the specific applicable requirements of Owner's and Contractor's safety programs of which Engineer has been informed.

### **ARTICLE 11—CHANGES TO THE CONTRACT**

#### 11.01 *Amending and Supplementing the Contract*

- A. The Contract may be amended or supplemented by a Change Order, a Work Change Directive, or a Field Order.
- B. If an amendment or supplement to the Contract includes a change in the Contract Price or the Contract Times, such amendment or supplement must be set forth in a Change Order.
- C. All changes to the Contract that involve (1) the performance or acceptability of the Work, (2) the design (as set forth in the Drawings, Specifications, or otherwise), or (3) other engineering or technical matters, must be supported by Engineer's recommendation. Owner and Contractor may amend other terms and conditions of the Contract without the recommendation of the Engineer.

#### 11.02 *Change Orders*

- A. Owner and Contractor shall execute appropriate Change Orders covering:
  - 1. Changes in Contract Price or Contract Times which are agreed to by the parties, including any undisputed sum or amount of time for Work actually performed in accordance with a Work Change Directive;
  - 2. Changes in Contract Price resulting from an Owner set-off, unless Contractor has duly contested such set-off;
  - 3. Changes in the Work which are: (a) ordered by Owner pursuant to Paragraph 11.05, (b) required because of Owner's acceptance of defective Work under Paragraph 14.04 or Owner's correction of defective Work under Paragraph 14.07, or (c) agreed to by the parties, subject to the need for Engineer's recommendation if the change in the Work involves the design (as set forth in the Drawings, Specifications, or otherwise) or other engineering or technical matters; and
  - 4. Changes that embody the substance of any final and binding results under: Paragraph 11.03.B, resolving the impact of a Work Change Directive; Paragraph 11.09, concerning Change Proposals; Article 12, Claims; Paragraph 13.02.D, final adjustments resulting from allowances; Paragraph 13.03.D, final adjustments relating to determination of quantities for Unit Price Work; and similar provisions.



- B. If Owner or Contractor refuses to execute a Change Order that is required to be executed under the terms of Paragraph 11.02.A, it will be deemed to be of full force and effect, as if fully executed.

#### 11.03 *Work Change Directives*

- A. A Work Change Directive will not change the Contract Price or the Contract Times but is evidence that the parties expect that the modification ordered or documented by a Work Change Directive will be incorporated in a subsequently issued Change Order, following negotiations by the parties as to the Work Change Directive's effect, if any, on the Contract Price and Contract Times; or, if negotiations are unsuccessful, by a determination under the terms of the Contract Documents governing adjustments, expressly including Paragraph 11.07 regarding change of Contract Price.
- B. If Owner has issued a Work Change Directive and:
  - 1. Contractor believes that an adjustment in Contract Times or Contract Price is necessary, then Contractor shall submit any Change Proposal seeking such an adjustment no later than 30 days after the completion of the Work set out in the Work Change Directive.
  - 2. Owner believes that an adjustment in Contract Times or Contract Price is necessary, then Owner shall submit any Claim seeking such an adjustment no later than 60 days after issuance of the Work Change Directive.

#### 11.04 *Field Orders*

- A. Engineer may authorize minor changes in the Work if the changes do not involve an adjustment in the Contract Price or the Contract Times and are compatible with the design concept of the completed Project as a functioning whole as indicated by the Contract Documents. Such changes will be accomplished by a Field Order and will be binding on Owner and also on Contractor, which shall perform the Work involved promptly.
- B. If Contractor believes that a Field Order justifies an adjustment in the Contract Price or Contract Times, then before proceeding with the Work at issue, Contractor shall submit a Change Proposal as provided herein.

#### 11.05 *Owner-Authorized Changes in the Work*

- A. Without invalidating the Contract and without notice to any surety, Owner may, at any time or from time to time, order additions, deletions, or revisions in the Work. Changes involving the design (as set forth in the Drawings, Specifications, or otherwise) or other engineering or technical matters will be supported by Engineer's recommendation.
- B. Such changes in the Work may be accomplished by a Change Order, if Owner and Contractor have agreed as to the effect, if any, of the changes on Contract Times or Contract Price; or by a Work Change Directive. Upon receipt of any such document, Contractor shall promptly proceed with the Work involved; or, in the case of a deletion in the Work, promptly cease construction activities with respect to such deleted Work. Added or revised Work must be performed under the applicable conditions of the Contract Documents.
- C. Nothing in this Paragraph 11.05 obligates Contractor to undertake work that Contractor reasonably concludes cannot be performed in a manner consistent with Contractor's safety obligations under the Contract Documents or Laws and Regulations.

11.06 *Unauthorized Changes in the Work*

- A. Contractor shall not be entitled to an increase in the Contract Price or an extension of the Contract Times with respect to any work performed that is not required by the Contract Documents, as amended, modified, or supplemented, except in the case of an emergency as provided in Paragraph 7.15 or in the case of uncovering Work as provided in Paragraph 14.05.C.2.

11.07 *Change of Contract Price*

- A. The Contract Price may only be changed by a Change Order. Any Change Proposal for an adjustment in the Contract Price must comply with the provisions of Paragraph 11.09. Any Claim for an adjustment of Contract Price must comply with the provisions of Article 12.
- B. An adjustment in the Contract Price will be determined as follows:
  - 1. Where the Work involved is covered by unit prices contained in the Contract Documents, then by application of such unit prices to the quantities of the items involved (subject to the provisions of Paragraph 13.03);
  - 2. Where the Work involved is not covered by unit prices contained in the Contract Documents, then by a mutually agreed lump sum (which may include an allowance for overhead and profit not necessarily in accordance with Paragraph 11.07.C.2); or
  - 3. Where the Work involved is not covered by unit prices contained in the Contract Documents and the parties do not reach mutual agreement to a lump sum, then on the basis of the Cost of the Work (determined as provided in Paragraph 13.01) plus a Contractor's fee for overhead and profit (determined as provided in Paragraph 11.07.C).
- C. *Contractor's Fee:* When applicable, the Contractor's fee for overhead and profit will be determined as follows:
  - 1. A mutually acceptable fixed fee; or
  - 2. If a fixed fee is not agreed upon, then a fee based on the following percentages of the various portions of the Cost of the Work:
    - a. For costs incurred under Paragraphs 13.01.B.1 and 13.01.B.2, the Contractor's fee will be 15 percent;
    - b. For costs incurred under Paragraph 13.01.B.3, the Contractor's fee will be 5 percent;
    - c. Where one or more tiers of subcontracts are on the basis of Cost of the Work plus a fee and no fixed fee is agreed upon, the intent of Paragraphs 11.07.C.2.a and 11.07.C.2.b is that the Contractor's fee will be based on: (1) a fee of 15 percent of the costs incurred under Paragraphs 13.01.B.1 and 13.01.B.2 by the Subcontractor that actually performs the Work, at whatever tier, and (2) with respect to Contractor itself and to any Subcontractors of a tier higher than that of the Subcontractor that actually performs the Work, a fee of 5 percent of the amount (fee plus underlying costs incurred) attributable to the next lower tier Subcontractor; provided, however, that for any such subcontracted Work the maximum total fee to be paid by Owner will be no greater than 27 percent of the costs incurred by the Subcontractor that actually performs the Work;

- d. No fee will be payable on the basis of costs itemized under Paragraphs 13.01.B.4, 13.01.B.5, and 13.01.C;
- e. The amount of credit to be allowed by Contractor to Owner for any change which results in a net decrease in Cost of the Work will be the amount of the actual net decrease in Cost of the Work and a deduction of an additional amount equal to 5 percent of such actual net decrease in Cost of the Work; and
- f. When both additions and credits are involved in any one change or Change Proposal, the adjustment in Contractor's fee will be computed by determining the sum of the costs in each of the cost categories in Paragraph 13.01.B (specifically, payroll costs, Paragraph 13.01.B.1; incorporated materials and equipment costs, Paragraph 13.01.B.2; Subcontract costs, Paragraph 13.01.B.3; special consultants costs, Paragraph 13.01.B.4; and other costs, Paragraph 13.01.B.5) and applying to each such cost category sum the appropriate fee from Paragraphs 11.07.C.2.a through 11.07.C.2.e, inclusive.

#### 11.08 *Change of Contract Times*

- A. The Contract Times may only be changed by a Change Order. Any Change Proposal for an adjustment in the Contract Times must comply with the provisions of Paragraph 11.09. Any Claim for an adjustment in the Contract Times must comply with the provisions of Article 12.
- B. Delay, disruption, and interference in the Work, and any related changes in Contract Times, are addressed in and governed by Paragraph 4.05.

#### 11.09 *Change Proposals*

- A. *Purpose and Content:* Contractor shall submit a Change Proposal to Engineer to request an adjustment in the Contract Times or Contract Price; contest an initial decision by Engineer concerning the requirements of the Contract Documents or relating to the acceptability of the Work under the Contract Documents; challenge a set-off against payment due; or seek other relief under the Contract. The Change Proposal will specify any proposed change in Contract Times or Contract Price, or other proposed relief, and explain the reason for the proposed change, with citations to any governing or applicable provisions of the Contract Documents. Each Change Proposal will address only one issue, or a set of closely related issues.
- B. *Change Proposal Procedures*
  - 1. *Submittal:* Contractor shall submit each Change Proposal to Engineer within 30 days after the start of the event giving rise thereto, or after such initial decision.
  - 2. *Supporting Data:* The Contractor shall submit supporting data, including the proposed change in Contract Price or Contract Time (if any), to the Engineer and Owner within 15 days after the submittal of the Change Proposal.
    - a. Change Proposals based on or related to delay, interruption, or interference must comply with the provisions of Paragraphs 4.05.D and 4.05.E.
    - b. Change proposals related to a change of Contract Price must include full and detailed accounts of materials incorporated into the Work and labor and equipment used for the subject Work.

The supporting data must be accompanied by a written statement that the supporting data are accurate and complete, and that any requested time or price adjustment is the entire adjustment to which Contractor believes it is entitled as a result of said event.

3. *Engineer's Initial Review*: Engineer will advise Owner regarding the Change Proposal and consider any comments or response from Owner regarding the Change Proposal. If in its discretion Engineer concludes that additional supporting data is needed before conducting a full review and making a decision regarding the Change Proposal, then Engineer may request that Contractor submit such additional supporting data by a date specified by Engineer, prior to Engineer beginning its full review of the Change Proposal.
  4. *Engineer's Full Review and Action on the Change Proposal*: Upon receipt of Contractor's supporting data (including any additional data requested by Engineer), Engineer will conduct a full review of each Change Proposal and, within 30 days after such receipt of the Contractor's supporting data, either approve the Change Proposal in whole, deny it in whole, or approve it in part and deny it in part. Such actions must be in writing, with a copy provided to Owner and Contractor. If Engineer does not take action on the Change Proposal within 30 days, then either Owner or Contractor may at any time thereafter submit a letter to the other party indicating that as a result of Engineer's inaction the Change Proposal is deemed denied, thereby commencing the time for appeal of the denial under Article 12.
  5. *Binding Decision*: Engineer's decision is final and binding upon Owner and Contractor, unless Owner or Contractor appeals the decision by filing a Claim under Article 12.
- C. *Resolution of Certain Change Proposals*: If the Change Proposal does not involve the design (as set forth in the Drawings, Specifications, or otherwise), the acceptability of the Work, or other engineering or technical matters, then Engineer will notify the parties in writing that the Engineer is unable to resolve the Change Proposal. For purposes of further resolution of such a Change Proposal, such notice will be deemed a denial, and Contractor may choose to seek resolution under the terms of Article 12.
- D. *Post-Completion*: Contractor shall not submit any Change Proposals after Engineer issues a written recommendation of final payment pursuant to Paragraph 15.06.B.

#### 11.10 *Notification to Surety*

- A. If the provisions of any bond require notice to be given to a surety of any change affecting the general scope of the Work or the provisions of the Contract Documents (including, but not limited to, Contract Price or Contract Times), the giving of any such notice will be Contractor's responsibility. The amount of each applicable bond will be adjusted to reflect the effect of any such change.

## **ARTICLE 12—CLAIMS**

### 12.01 *Claims*

- A. *Claims Process*: The following disputes between Owner and Contractor are subject to the Claims process set forth in this article:
1. Appeals by Owner or Contractor of Engineer's decisions regarding Change Proposals;

2. Owner demands for adjustments in the Contract Price or Contract Times, or other relief under the Contract Documents;
  3. Disputes that Engineer has been unable to address because they do not involve the design (as set forth in the Drawings, Specifications, or otherwise), the acceptability of the Work, or other engineering or technical matters; and
  4. Subject to the waiver provisions of Paragraph 15.07, any dispute arising after Engineer has issued a written recommendation of final payment pursuant to Paragraph 15.06.B.
- B. *Submittal of Claim:* The party submitting a Claim shall deliver it directly to the other party to the Contract promptly (but in no event later than 30 days) after the start of the event giving rise thereto; in the case of appeals regarding Change Proposals within 30 days of the decision under appeal. The party submitting the Claim shall also furnish a copy to the Engineer, for its information only. The responsibility to substantiate a Claim rests with the party making the Claim. In the case of a Claim by Contractor seeking an increase in the Contract Times or Contract Price, Contractor shall certify that the Claim is made in good faith, that the supporting data are accurate and complete, and that to the best of Contractor's knowledge and belief the amount of time or money requested accurately reflects the full amount to which Contractor is entitled.
- C. *Review and Resolution:* The party receiving a Claim shall review it thoroughly, giving full consideration to its merits. The two parties shall seek to resolve the Claim through the exchange of information and direct negotiations. The parties may extend the time for resolving the Claim by mutual agreement. All actions taken on a Claim will be stated in writing and submitted to the other party, with a copy to Engineer.
- D. *Mediation*
1. At any time after initiation of a Claim, Owner and Contractor may mutually agree to mediation of the underlying dispute. The agreement to mediate will stay the Claim submittal and response process.
  2. If Owner and Contractor agree to mediation, then after 60 days from such agreement, either Owner or Contractor may unilaterally terminate the mediation process, and the Claim submittal and decision process will resume as of the date of the termination. If the mediation proceeds but is unsuccessful in resolving the dispute, the Claim submittal and decision process will resume as of the date of the conclusion of the mediation, as determined by the mediator.
  3. Owner and Contractor shall each pay one-half of the mediator's fees and costs.
- E. *Partial Approval:* If the party receiving a Claim approves the Claim in part and denies it in part, such action will be final and binding unless within 30 days of such action the other party invokes the procedure set forth in Article 17 for final resolution of disputes.
- F. *Denial of Claim:* If efforts to resolve a Claim are not successful, the party receiving the Claim may deny it by giving written notice of denial to the other party. If the receiving party does not take action on the Claim within 90 days, then either Owner or Contractor may at any time thereafter submit a letter to the other party indicating that as a result of the inaction, the Claim is deemed denied, thereby commencing the time for appeal of the denial. A denial of the Claim will be final and binding unless within 30 days of the denial the other party invokes the procedure set forth in Article 17 for the final resolution of disputes.

- G. *Final and Binding Results*: If the parties reach a mutual agreement regarding a Claim, whether through approval of the Claim, direct negotiations, mediation, or otherwise; or if a Claim is approved in part and denied in part, or denied in full, and such actions become final and binding; then the results of the agreement or action on the Claim will be incorporated in a Change Order or other written document to the extent they affect the Contract, including the Work, the Contract Times, or the Contract Price.

## **ARTICLE 13—COST OF THE WORK; ALLOWANCES; UNIT PRICE WORK**

### **13.01 Cost of the Work**

- A. *Purposes for Determination of Cost of the Work*: The term Cost of the Work means the sum of all costs necessary for the proper performance of the Work at issue, as further defined below. The provisions of this Paragraph 13.01 are used for two distinct purposes:
1. To determine Cost of the Work when Cost of the Work is a component of the Contract Price, under cost-plus-fee, time-and-materials, or other cost-based terms; or
  2. When needed to determine the value of a Change Order, Change Proposal, Claim, set-off, or other adjustment in Contract Price. When the value of any such adjustment is determined on the basis of Cost of the Work, Contractor is entitled only to those additional or incremental costs required because of the change in the Work or because of the event giving rise to the adjustment.
- B. *Costs Included*: Except as otherwise may be agreed to in writing by Owner, costs included in the Cost of the Work will be in amounts no higher than those commonly incurred in the locality of the Project, will not include any of the costs itemized in Paragraph 13.01.C, and will include only the following items:
1. Payroll costs for employees in the direct employ of Contractor in the performance of the Work under schedules of job classifications agreed upon by Owner and Contractor in advance of the subject Work. Such employees include, without limitation, superintendents, foremen, safety managers, safety representatives, and other personnel employed full time on the Work. Payroll costs for employees not employed full time on the Work will be apportioned on the basis of their time spent on the Work. Payroll costs include, but are not limited to, salaries and wages plus the cost of fringe benefits, which include social security contributions, unemployment, excise, and payroll taxes, workers' compensation, health and retirement benefits, sick leave, and vacation and holiday pay applicable thereto. The expenses of performing Work outside of regular working hours, on Saturday, Sunday, or legal holidays, will be included in the above to the extent authorized by Owner.
  2. Cost of all materials and equipment furnished and incorporated in the Work, including costs of transportation and storage thereof, and Suppliers' field services required in connection therewith. All cash discounts accrue to Contractor unless Owner deposits funds with Contractor with which to make payments, in which case the cash discounts will accrue to Owner. All trade discounts, rebates, and refunds and returns from sale of surplus materials and equipment will accrue to Owner, and Contractor shall make provisions so that they may be obtained.
  3. Payments made by Contractor to Subcontractors for Work performed by Subcontractors. If required by Owner, Contractor shall obtain competitive bids from subcontractors

acceptable to Owner and Contractor and shall deliver such bids to Owner, which will then determine, with the advice of Engineer, which bids, if any, will be acceptable. If any subcontract provides that the Subcontractor is to be paid on the basis of Cost of the Work plus a fee, the Subcontractor's Cost of the Work and fee will be determined in the same manner as Contractor's Cost of the Work and fee as provided in this Paragraph 13.01.

4. Costs of special consultants (including but not limited to engineers, architects, testing laboratories, surveyors, attorneys, and accountants) employed or retained for services specifically related to the Work.
5. Other costs consisting of the following:
  - a. The proportion of necessary transportation, travel, and subsistence expenses of Contractor's employees incurred in discharge of duties connected with the Work.
  - b. Cost, including transportation and maintenance, of all materials, supplies, equipment, machinery, appliances, office, and temporary facilities at the Site, which are consumed in the performance of the Work, and cost, less market value, of such items used but not consumed which remain the property of Contractor.
    - 1) In establishing included costs for materials such as scaffolding, plating, or sheeting, consideration will be given to the actual or the estimated life of the material for use on other projects; or rental rates may be established on the basis of purchase or salvage value of such items, whichever is less. Contractor will not be eligible for compensation for such items in an amount that exceeds the purchase cost of such item.
  - c. *Construction Equipment Rental*

Rentals of all construction equipment and machinery, and the parts thereof, whether rented from Contractor or others in accordance with rental agreements approved by Owner with the advice of Engineer, and the costs of transportation, loading, unloading, assembly, dismantling, and removal thereof. All such costs shall be in accordance with the terms of said rental agreements. The rental of any such equipment, machinery, or parts shall cease when the use thereof is no longer necessary for the Work.
  - d. Sales, consumer, use, and other similar taxes related to the Work, and for which Contractor is liable, as imposed by Laws and Regulations.
  - e. Deposits lost for causes other than negligence of Contractor, any Subcontractor, or anyone directly or indirectly employed by any of them or for whose acts any of them may be liable, and royalty payments and fees for permits and licenses.
  - f. Losses and damages (and related expenses) caused by damage to the Work, not compensated by insurance or otherwise, sustained by Contractor in connection with the performance of the Work (except losses and damages within the deductible amounts of builder's risk or other property insurance established in accordance with Paragraph 6.04), provided such losses and damages have resulted from causes other than the negligence of Contractor, any Subcontractor, or anyone directly or indirectly employed by any of them or for whose acts any of them may be liable. Such losses include settlements made with the written consent and approval of Owner. No such

losses, damages, and expenses will be included in the Cost of the Work for the purpose of determining Contractor's fee.

- g. The cost of utilities, fuel, and sanitary facilities at the Site.
- h. Minor expenses such as communication service at the Site, express and courier services, and similar petty cash items in connection with the Work.
- i. The costs of premiums for all bonds and insurance that Contractor is required by the Contract Documents to purchase and maintain.

C. *Costs Excluded*: The term Cost of the Work does not include any of the following items:

- 1. Payroll costs and other compensation of Contractor's officers, executives, principals, general managers, engineers, architects, estimators, attorneys, auditors, accountants, purchasing and contracting agents, expeditors, timekeepers, clerks, and other personnel employed by Contractor, whether at the Site or in Contractor's principal or branch office for general administration of the Work and not specifically included in the agreed upon schedule of job classifications referred to in Paragraph 13.01.B.1 or specifically covered by Paragraph 13.01.B.4. The payroll costs and other compensation excluded here are to be considered administrative costs covered by the Contractor's fee.
- 2. The cost of purchasing, renting, or furnishing small tools and hand tools.
- 3. Expenses of Contractor's principal and branch offices other than Contractor's office at the Site.
- 4. Any part of Contractor's capital expenses, including interest on Contractor's capital employed for the Work and charges against Contractor for delinquent payments.
- 5. Costs due to the negligence of Contractor, any Subcontractor, or anyone directly or indirectly employed by any of them or for whose acts any of them may be liable, including but not limited to, the correction of defective Work, disposal of materials or equipment wrongly supplied, and making good any damage to property.
- 6. Expenses incurred in preparing and advancing Claims.
- 7. Other overhead or general expense costs of any kind and the costs of any item not specifically and expressly included in Paragraph 13.01.B.

D. *Contractor's Fee*

- 1. When the Work as a whole is performed on the basis of cost-plus-a-fee, then:
  - a. Contractor's fee for the Work set forth in the Contract Documents as of the Effective Date of the Contract will be determined as set forth in the Agreement.
  - b. for any Work covered by a Change Order, Change Proposal, Claim, set-off, or other adjustment in Contract Price on the basis of Cost of the Work, Contractor's fee will be determined as follows:
    - 1) When the fee for the Work as a whole is a percentage of the Cost of the Work, the fee will automatically adjust as the Cost of the Work changes.
    - 2) When the fee for the Work as a whole is a fixed fee, the fee for any additions or deletions will be determined in accordance with Paragraph 11.07.C.2.



2. When the Work as a whole is performed on the basis of a stipulated sum, or any other basis other than cost-plus-a-fee, then Contractor's fee for any Work covered by a Change Order, Change Proposal, Claim, set-off, or other adjustment in Contract Price on the basis of Cost of the Work will be determined in accordance with Paragraph 11.07.C.2.
- E. *Documentation and Audit*: Whenever the Cost of the Work for any purpose is to be determined pursuant to this Article 13, Contractor and pertinent Subcontractors shall establish and maintain records of the costs in accordance with generally accepted accounting practices. Subject to prior written notice, Owner will be afforded reasonable access, during normal business hours, to all Contractor's accounts, records, books, correspondence, instructions, drawings, receipts, vouchers, memoranda, and similar data relating to the Cost of the Work and Contractor's fee. Contractor shall preserve all such documents for a period of three years after the final payment by Owner. Pertinent Subcontractors will afford such access to Owner, and preserve such documents, to the same extent required of Contractor.

### 13.02 Allowances

- A. It is understood that Contractor has included in the Contract Price all allowances so named in the Contract Documents and shall cause the Work so covered to be performed for such sums and by such persons or entities as may be acceptable to Owner and Engineer.
- B. *Cash Allowances*: Contractor agrees that:
1. the cash allowances include the cost to Contractor (less any applicable trade discounts) of materials and equipment required by the allowances to be delivered at the Site, and all applicable taxes; and
  2. Contractor's costs for unloading and handling on the Site, labor, installation, overhead, profit, and other expenses contemplated for the cash allowances have been included in the Contract Price and not in the allowances, and no demand for additional payment for any of the foregoing will be valid.
- C. *Owner's Contingency Allowance*: Contractor agrees that an Owner's contingency allowance, if any, is for the sole use of Owner to cover unanticipated costs.
- D. Prior to final payment, an appropriate Change Order will be issued as recommended by Engineer to reflect actual amounts due Contractor for Work covered by allowances, and the Contract Price will be correspondingly adjusted.

### 13.03 Unit Price Work

- A. Where the Contract Documents provide that all or part of the Work is to be Unit Price Work, initially the Contract Price will be deemed to include for all Unit Price Work an amount equal to the sum of the unit price for each separately identified item of Unit Price Work times the estimated quantity of each item as indicated in the Agreement.
- B. The estimated quantities of items of Unit Price Work are not guaranteed and are solely for the purpose of comparison of Bids and determining an initial Contract Price. Payments to Contractor for Unit Price Work will be based on actual quantities.
- C. Each unit price will be deemed to include an amount considered by Contractor to be adequate to cover Contractor's overhead and profit for each separately identified item.
- D. Engineer will determine the actual quantities and classifications of Unit Price Work performed by Contractor. Engineer will review with Contractor the Engineer's preliminary

determinations on such matters before rendering a written decision thereon (by recommendation of an Application for Payment or otherwise). Engineer's written decision thereon will be final and binding (except as modified by Engineer to reflect changed factual conditions or more accurate data) upon Owner and Contractor, and the final adjustment of Contract Price will be set forth in a Change Order, subject to the provisions of the following paragraph.

E. *Adjustments in Unit Price*

Within 30 days of Engineer's written decision under the preceding paragraph, Contractor may submit a Change Proposal, or Owner may file a Claim, seeking an adjustment in the Contract Price if:

the quantity of any item of Unit Price Work performed by Contractor differs materially and significantly from the estimated quantity of such item indicated in the Agreement;

there is no corresponding adjustment with respect to any other item of Work; and

Contractor believes that it is entitled to an increase in Contract Price as a result of having incurred additional expense or Owner believes that Owner is entitled to a decrease in Contract Price, and the parties are unable to agree as to the amount of any such increase or decrease.

**ARTICLE 14—TESTS AND INSPECTIONS; CORRECTION, REMOVAL, OR ACCEPTANCE OF DEFECTIVE WORK**

14.01 *Access to Work*

- A. Owner, Engineer, their consultants and other representatives and personnel of Owner, independent testing laboratories, and authorities having jurisdiction have access to the Site and the Work at reasonable times for their observation, inspection, and testing. Contractor shall provide them proper and safe conditions for such access and advise them of Contractor's safety procedures and programs so that they may comply with such procedures and programs as applicable.

14.02 *Tests, Inspections, and Approvals*

- A. Contractor shall give Engineer timely notice of readiness of the Work (or specific parts thereof) for all required inspections and tests and shall cooperate with inspection and testing personnel to facilitate required inspections and tests.
- B. This item intentionally deleted from these General Conditions. Section 2 – Testing and Control of Materials in the Specifications covers this subject.
- C. If Laws or Regulations of any public body having jurisdiction require any Work (or part thereof) specifically to be inspected, tested, or approved by an employee or other representative of such public body, Contractor shall assume full responsibility for arranging and obtaining such inspections, tests, or approvals, pay all costs in connection therewith, and furnish Engineer the required certificates of inspection or approval.
- D. Contractor shall be responsible for arranging, obtaining, and paying for all inspections and tests required:
1. by the Contract Documents, unless the Contract Documents expressly allocate responsibility for a specific inspection or test to Owner;

2. to attain Owner's and Engineer's acceptance of materials or equipment to be incorporated in the Work;
3. by manufacturers of equipment furnished under the Contract Documents;
4. for testing, adjusting, and balancing of mechanical, electrical, and other equipment to be incorporated into the Work; and
5. for acceptance of materials, mix designs, or equipment submitted for approval prior to Contractor's purchase thereof for incorporation in the Work.

Such inspections and tests will be performed by independent inspectors, testing laboratories, or other qualified individuals or entities acceptable to Owner and Engineer.

- E. If the Contract Documents require the Work (or part thereof) to be approved by Owner, Engineer, or another designated individual or entity, then Contractor shall assume full responsibility for arranging and obtaining such approvals.
- F. If any Work (or the work of others) that is to be inspected, tested, or approved is covered by Contractor without written concurrence of Engineer, Contractor shall, if requested by Engineer, uncover such Work for observation. Such uncovering will be at Contractor's expense unless Contractor had given Engineer timely notice of Contractor's intention to cover the same and Engineer had not acted with reasonable promptness in response to such notice.

#### 14.03 *Defective Work*

- A. *Contractor's Obligation*: It is Contractor's obligation to assure that the Work is not defective.
- B. *Engineer's Authority*: Engineer has the authority to determine whether Work is defective, and to reject defective Work.
- C. *Notice of Defects*: Prompt written notice of all defective Work of which Owner or Engineer has actual knowledge will be given to Contractor.
- D. *Correction, or Removal and Replacement*: Promptly after receipt of written notice of defective Work, Contractor shall correct all such defective Work, whether or not fabricated, installed, or completed, or, if Engineer has rejected the defective Work, remove it from the Project and replace it with Work that is not defective.
- E. *Preservation of Warranties*: When correcting defective Work, Contractor shall take no action that would void or otherwise impair Owner's special warranty and guarantee, if any, on said Work.
- F. *Costs and Damages*: In addition to its correction, removal, and replacement obligations with respect to defective Work, Contractor shall pay all claims, costs, losses, and damages arising out of or relating to defective Work, including but not limited to the cost of the inspection, testing, correction, removal, replacement, or reconstruction of such defective Work, fines levied against Owner by governmental authorities because the Work is defective, and the costs of repair or replacement of work of others resulting from defective Work. Prior to final payment, if Owner and Contractor are unable to agree as to the measure of such claims, costs, losses, and damages resulting from defective Work, then Owner may impose a reasonable set-off against payments due under Article 15.

#### 14.04 *Acceptance of Defective Work*

- A. If, instead of requiring correction or removal and replacement of defective Work, Owner prefers to accept it, Owner may do so (subject, if such acceptance occurs prior to final payment, to Engineer's confirmation that such acceptance is in general accord with the design intent and applicable engineering principles and will not endanger public safety). Contractor shall pay all claims, costs, losses, and damages attributable to Owner's evaluation of and determination to accept such defective Work (such costs to be approved by Engineer as to reasonableness), and for the diminished value of the Work to the extent not otherwise paid by Contractor. If any such acceptance occurs prior to final payment, the necessary revisions in the Contract Documents with respect to the Work will be incorporated in a Change Order. If the parties are unable to agree as to the decrease in the Contract Price, reflecting the diminished value of Work so accepted, then Owner may impose a reasonable set-off against payments due under Article 15. If the acceptance of defective Work occurs after final payment, Contractor shall pay an appropriate amount to Owner.

#### 14.05 *Uncovering Work*

- A. Engineer has the authority to require additional inspection or testing of the Work, whether or not the Work is fabricated, installed, or completed.
- B. If any Work is covered contrary to the written request of Engineer, then Contractor shall, if requested by Engineer, uncover such Work for Engineer's observation, and then replace the covering, all at Contractor's expense.
- C. If Engineer considers it necessary or advisable that covered Work be observed by Engineer or inspected or tested by others, then Contractor, at Engineer's request, shall uncover, expose, or otherwise make available for observation, inspection, or testing as Engineer may require, that portion of the Work in question, and provide all necessary labor, material, and equipment.
  - 1. If it is found that the uncovered Work is defective, Contractor shall be responsible for all claims, costs, losses, and damages arising out of or relating to such uncovering, exposure, observation, inspection, and testing, and of satisfactory replacement or reconstruction (including but not limited to all costs of repair or replacement of work of others); and pending Contractor's full discharge of this responsibility the Owner shall be entitled to impose a reasonable set-off against payments due under Article 15.
  - 2. If the uncovered Work is not found to be defective, Contractor shall be allowed an increase in the Contract Price or an extension of the Contract Times, directly attributable to such uncovering, exposure, observation, inspection, testing, replacement, and reconstruction. If the parties are unable to agree as to the amount or extent thereof, then Contractor may submit a Change Proposal within 30 days of the determination that the Work is not defective.

#### 14.06 *Owner May Stop the Work*

- A. If the Work is defective, or Contractor fails to supply sufficient skilled workers or suitable materials or equipment, or fails to perform the Work in such a way that the completed Work will conform to the Contract Documents, then Owner may order Contractor to stop the Work, or any portion thereof, until the cause for such order has been eliminated; however, this right of Owner to stop the Work will not give rise to any duty on the part of Owner to exercise this

right for the benefit of Contractor, any Subcontractor, any Supplier, any other individual or entity, or any surety for, or employee or agent of any of them.

**14.07 Owner May Correct Defective Work**

- A. If Contractor fails within a reasonable time after written notice from Engineer to correct defective Work, or to remove and replace defective Work as required by Engineer, then Owner may, after 7 days' written notice to Contractor, correct or remedy any such deficiency.
- B. In exercising the rights and remedies under this Paragraph 14.07, Owner shall proceed expeditiously. In connection with such corrective or remedial action, Owner may exclude Contractor from all or part of the Site, take possession of all or part of the Work and suspend Contractor's services related thereto, and incorporate in the Work all materials and equipment stored at the Site or for which Owner has paid Contractor but which are stored elsewhere. Contractor shall allow Owner, Owner's representatives, agents and employees, Owner's other contractors, and Engineer and Engineer's consultants access to the Site to enable Owner to exercise the rights and remedies under this paragraph.
- C. All claims, costs, losses, and damages incurred or sustained by Owner in exercising the rights and remedies under this Paragraph 14.07 will be charged against Contractor as set-offs against payments due under Article 15. Such claims, costs, losses and damages will include but not be limited to all costs of repair, or replacement of work of others destroyed or damaged by correction, removal, or replacement of Contractor's defective Work.
- D. Contractor shall not be allowed an extension of the Contract Times because of any delay in the performance of the Work attributable to the exercise by Owner of Owner's rights and remedies under this Paragraph 14.07.

**ARTICLE 15—PAYMENTS TO CONTRACTOR; SET-OFFS; COMPLETION; CORRECTION PERIOD**

**15.01 Progress Payments**

- A. *Basis for Progress Payments:* The Schedule of Values established as provided in Article 2 will serve as the basis for progress payments and will be incorporated into a form of Application for Payment acceptable to Engineer. Progress payments for Unit Price Work will be based on the number of units completed during the pay period, as determined under the provisions of Paragraph 13.03. Progress payments for cost-based Work will be based on Cost of the Work completed by Contractor during the pay period.
- B. *Applications for Payments*
  - 1. At least 20 days before the date established in the Agreement for each progress payment (but not more often than once a month), Contractor shall submit to Engineer for review an Application for Payment filled out and signed by Contractor covering the Work completed as of the date of the Application and accompanied by such supporting documentation as is required by the Contract Documents.
  - 2. If payment is requested on the basis of materials and equipment not incorporated in the Work but delivered and suitably stored at the Site or at another location agreed to in writing, the Application for Payment must also be accompanied by: (a) a bill of sale, invoice, copies of subcontract or purchase order payments, or other documentation establishing full payment by Contractor for the materials and equipment; (b) at Owner's request, documentation warranting that Owner has received the materials and

equipment free and clear of all Liens; and (c) evidence that the materials and equipment are covered by appropriate property insurance, a warehouse bond, or other arrangements to protect Owner's interest therein, all of which must be satisfactory to Owner.

3. Beginning with the second Application for Payment, each Application must include an affidavit of Contractor stating that all previous progress payments received by Contractor have been applied to discharge Contractor's legitimate obligations associated with prior Applications for Payment.
4. The amount of retainage with respect to progress payments will be as stipulated in the Agreement.

C. *Review of Applications*

1. Engineer will, within 10 days after receipt of each Application for Payment, including each resubmittal, either indicate in writing a recommendation of payment and present the Application to Owner, or return the Application to Contractor indicating in writing Engineer's reasons for refusing to recommend payment. In the latter case, Contractor may make the necessary corrections and resubmit the Application.
2. Engineer's recommendation of any payment requested in an Application for Payment will constitute a representation by Engineer to Owner, based on Engineer's observations of the executed Work as an experienced and qualified design professional, and on Engineer's review of the Application for Payment and the accompanying data and schedules, that to the best of Engineer's knowledge, information and belief:
  - a. the Work has progressed to the point indicated;
  - b. the quality of the Work is generally in accordance with the Contract Documents (subject to an evaluation of the Work as a functioning whole prior to or upon Substantial Completion, the results of any subsequent tests called for in the Contract Documents, a final determination of quantities and classifications for Unit Price Work under Paragraph 13.03, and any other qualifications stated in the recommendation); and
  - c. the conditions precedent to Contractor's being entitled to such payment appear to have been fulfilled in so far as it is Engineer's responsibility to observe the Work.
3. By recommending any such payment Engineer will not thereby be deemed to have represented that:
  - a. inspections made to check the quality or the quantity of the Work as it has been performed have been exhaustive, extended to every aspect of the Work in progress, or involved detailed inspections of the Work beyond the responsibilities specifically assigned to Engineer in the Contract; or
  - b. there may not be other matters or issues between the parties that might entitle Contractor to be paid additionally by Owner or entitle Owner to withhold payment to Contractor.

4. Neither Engineer's review of Contractor's Work for the purposes of recommending payments nor Engineer's recommendation of any payment, including final payment, will impose responsibility on Engineer:
  - a. to supervise, direct, or control the Work;
  - b. for the means, methods, techniques, sequences, or procedures of construction, or the safety precautions and programs incident thereto;
  - c. for Contractor's failure to comply with Laws and Regulations applicable to Contractor's performance of the Work;
  - d. to make any examination to ascertain how or for what purposes Contractor has used the money paid by Owner; or
  - e. to determine that title to any of the Work, materials, or equipment has passed to Owner free and clear of any Liens.
5. Engineer may refuse to recommend the whole or any part of any payment if, in Engineer's opinion, it would be incorrect to make the representations to Owner stated in Paragraph 15.01.C.2.
6. Engineer will recommend reductions in payment (set-offs) necessary in Engineer's opinion to protect Owner from loss because:
  - a. the Work is defective, requiring correction or replacement;
  - b. the Contract Price has been reduced by Change Orders;
  - c. Owner has been required to correct defective Work in accordance with Paragraph 14.07, or has accepted defective Work pursuant to Paragraph 14.04;
  - d. Owner has been required to remove or remediate a Hazardous Environmental Condition for which Contractor is responsible; or
  - e. Engineer has actual knowledge of the occurrence of any of the events that would constitute a default by Contractor and therefore justify termination for cause under the Contract Documents.

**D. *Payment Becomes Due***

1. The Owner will make payments promptly as funds for such payments become available from funding agencies or as otherwise agreed.

**E. *Reductions in Payment by Owner***

1. In addition to any reductions in payment (set-offs) recommended by Engineer, Owner is entitled to impose a set-off against payment based on any of the following:
  - a. Claims have been made against Owner based on Contractor's conduct in the performance or furnishing of the Work, or Owner has incurred costs, losses, or damages resulting from Contractor's conduct in the performance or furnishing of the Work, including but not limited to claims, costs, losses, or damages from workplace injuries, adjacent property damage, non-compliance with Laws and Regulations, and patent infringement;
  - b. Contractor has failed to take reasonable and customary measures to avoid damage, delay, disruption, and interference with other work at or adjacent to the Site;

- c. Contractor has failed to provide and maintain required bonds or insurance;
  - d. Owner has been required to remove or remediate a Hazardous Environmental Condition for which Contractor is responsible;
  - e. Owner has incurred extra charges or engineering costs related to submittal reviews, evaluations of proposed substitutes, tests and inspections, or return visits to manufacturing or assembly facilities;
  - f. The Work is defective, requiring correction or replacement;
  - g. Owner has been required to correct defective Work in accordance with Paragraph 14.07, or has accepted defective Work pursuant to Paragraph 14.04;
  - h. The Contract Price has been reduced by Change Orders;
  - i. An event has occurred that would constitute a default by Contractor and therefore justify a termination for cause;
  - j. Liquidated or other damages have accrued as a result of Contractor's failure to achieve Milestones, Substantial Completion, or final completion of the Work;
  - k. Liens have been filed in connection with the Work, except where Contractor has delivered a specific bond satisfactory to Owner to secure the satisfaction and discharge of such Liens; or
  - l. Other items entitle Owner to a set-off against the amount recommended.
2. If Owner imposes any set-off against payment, whether based on its own knowledge or on the written recommendations of Engineer, Owner will give Contractor immediate written notice (with a copy to Engineer) stating the reasons for such action and the specific amount of the reduction, and promptly pay Contractor any amount remaining after deduction of the amount so withheld. Owner shall promptly pay Contractor the amount so withheld, or any adjustment thereto agreed to by Owner and Contractor, if Contractor remedies the reasons for such action. The reduction imposed will be binding on Contractor unless it duly submits a Change Proposal contesting the reduction.
  3. Upon a subsequent determination that Owner's refusal of payment was not justified, the amount wrongfully withheld will be treated as an amount due as determined by Paragraph 15.01.D.1 and subject to interest as provided in the Agreement.

15.02 *Contractor's Warranty of Title*

- A. Contractor warrants and guarantees that title to all Work, materials, and equipment furnished under the Contract will pass to Owner free and clear of (1) all Liens and other title defects, and (2) all patent, licensing, copyright, or royalty obligations, no later than 7 days after the time of payment by Owner.

15.03 *Substantial Completion*

- A. When Contractor considers the entire Work ready for its intended use Contractor shall notify Owner and Engineer in writing that the entire Work is substantially complete and request that Engineer issue a notice of Substantial Completion. Contractor shall at the same time submit to Owner and Engineer an initial draft of punch list items to be completed or corrected before final payment.



- B. Promptly after Contractor's notification, Owner, Contractor, and Engineer shall make an inspection of the Work to determine the status of completion. If Engineer does not consider the Work substantially complete, Engineer will notify Contractor in writing giving the reasons therefor.
- C. If Engineer considers the Work substantially complete, Engineer will deliver to Owner and Contractor a preliminary notice of Substantial Completion which will fix the date of Substantial Completion. Engineer shall attach to the notice a punch list of items to be completed or corrected before final payment. Owner shall have 7 days after receipt of the preliminary notice during which to make written objection to Engineer as to any provisions of the notice or attached punch list. If, after considering the objections to the provisions of the preliminary notice, Engineer concludes that the Work is not substantially complete, Engineer will, within 14 days after submission of the preliminary notice to Owner, notify Contractor in writing that the Work is not substantially complete, stating the reasons therefor. If Owner does not object to the provisions of the notice, or if despite consideration of Owner's objections Engineer concludes that the Work is substantially complete, then Engineer will, within said 14 days, execute and deliver to Owner and Contractor a final notice of Substantial Completion (with a revised punch list of items to be completed or corrected) reflecting such changes from the preliminary notice as Engineer believes justified after consideration of any objections from Owner.
- D. At the time of receipt of the preliminary notice of Substantial Completion, Owner and Contractor will confer regarding Owner's use or occupancy of the Work following Substantial Completion, review the builder's risk insurance policy with respect to the end of the builder's risk coverage, and confirm the transition to coverage of the Work under a permanent property insurance policy held by Owner. Unless Owner and Contractor agree otherwise in writing, Owner shall bear responsibility for security, operation, protection of the Work, property insurance, maintenance, heat, and utilities upon Owner's use or occupancy of the Work.
- E. After Substantial Completion the Contractor shall promptly begin work on the punch list of items to be completed or corrected prior to final payment. In appropriate cases Contractor may submit monthly Applications for Payment for completed punch list items, following the progress payment procedures set forth above.
- F. Owner shall have the right to exclude Contractor from the Site after the date of Substantial Completion subject to allowing Contractor reasonable access to remove its property and complete or correct items on the punch list.

15.04 *Partial Use or Occupancy*

- A. Prior to Substantial Completion of all the Work, Owner may use or occupy any part of the Work which Owner, Engineer, and Contractor agree constitutes a separately functioning and usable part of the Work that can be used by Owner for its intended purpose without significant interference with Contractor's performance of the remainder of the Work.

15.05 *Final Inspection*

- A. Upon written notice from Contractor that the entire Work or an agreed portion thereof is complete, Engineer will promptly make a final inspection with Owner and Contractor and will notify Contractor in writing of all particulars in which this inspection reveals that the Work, or

agreed portion thereof, is incomplete or defective. Contractor shall immediately take such measures as are necessary to complete such Work or remedy such deficiencies.

#### 15.06 *Final Payment*

##### A. *Application for Payment*

1. After Contractor has, in the opinion of Engineer, satisfactorily completed all corrections identified during the final inspection and has delivered, in accordance with the Contract Documents, all maintenance and operating instructions, schedules, guarantees, bonds, certificates or other evidence of insurance, certificates of inspection, annotated record documents (as provided in Paragraph 7.12), and other documents, Contractor may make application for final payment.
  2. The final Application for Payment must be accompanied (except as previously delivered) by:
    - a. all documentation called for in the Contract Documents;
    - b. consent of the surety, if any, to final payment;
    - c. satisfactory evidence that all title issues have been resolved such that title to all Work, materials, and equipment has passed to Owner free and clear of any Liens or other title defects or will so pass upon final payment.
    - d. a list of all duly pending Change Proposals and Claims; and
    - e. complete and legally effective releases or waivers (satisfactory to Owner) of all Lien rights arising out of the Work, and of Liens filed in connection with the Work.
  3. In lieu of the releases or waivers of Liens specified in Paragraph 15.06.A.2 and as approved by Owner, Contractor may furnish receipts or releases in full and an affidavit of Contractor that: (a) the releases and receipts include all labor, services, material, and equipment for which a Lien could be filed; and (b) all payrolls, material and equipment bills, and other indebtedness connected with the Work for which Owner might in any way be responsible, or which might in any way result in liens or other burdens on Owner's property, have been paid or otherwise satisfied. If any Subcontractor or Supplier fails to furnish such a release or receipt in full, Contractor may furnish a bond or other collateral satisfactory to Owner to indemnify Owner against any Lien, or Owner at its option may issue joint checks payable to Contractor and specified Subcontractors and Suppliers.
- B. *Engineer's Review of Final Application and Recommendation of Payment:* If, on the basis of Engineer's observation of the Work during construction and final inspection, and Engineer's review of the final Application for Payment and accompanying documentation as required by the Contract Documents, Engineer is satisfied that the Work has been completed and Contractor's other obligations under the Contract have been fulfilled, Engineer will, within 10 days after receipt of the final Application for Payment, indicate in writing Engineer's recommendation of final payment and present the final Application for Payment to Owner for payment. Such recommendation will account for any set-offs against payment that are necessary in Engineer's opinion to protect Owner from loss for the reasons stated above with respect to progress payments. Otherwise, Engineer will return the Application for Payment to Contractor, indicating in writing the reasons for refusing to recommend final payment, in which case Contractor shall make the necessary corrections and resubmit the Application for Payment.

- C. *Notice of Acceptability*: In support of its recommendation of payment of the final Application for Payment, Engineer will also give written notice to Owner and Contractor that the Work is acceptable, subject to stated limitations in the notice and to the provisions of Paragraph 15.07.
- D. *Completion of Work*: The Work is complete (subject to surviving obligations) when it is ready for final payment as established by the Engineer's written recommendation of final payment.
- E. *Final Payment Becomes Due*: Upon receipt from Engineer of the final Application for Payment and accompanying documentation, Owner shall set off against the amount recommended by Engineer for final payment any further sum to which Owner is entitled, including but not limited to set-offs for liquidated damages and set-offs allowed under the provisions of this Contract with respect to progress payments. Owner shall pay the resulting balance due to Contractor.

#### 15.07 *Waiver of Claims*

- A. The making of final payment will not constitute a waiver by Owner of claims or rights against Contractor. Owner expressly reserves claims and rights arising from unsettled Liens, from defective Work appearing after final inspection pursuant to Paragraph 15.05, from Contractor's failure to comply with the Contract Documents or the terms of any special guarantees specified therein, from outstanding Claims by Owner, or from Contractor's continuing obligations under the Contract Documents.
- B. The acceptance of final payment by Contractor will constitute a waiver by Contractor of all claims and rights against Owner other than those pending matters that have been duly submitted as a Claim or appealed under the provisions of Article 17.

#### 15.08 *Correction Period*

- A. If within one year after the date of Substantial Completion (or such longer period of time as may be prescribed by the Supplementary Conditions or the terms of any applicable special guarantee required by the Contract Documents), Owner gives Contractor written notice that any Work has been found to be defective, or that Contractor's repair of any damages to the Site or adjacent areas has been found to be defective, then after receipt of such notice of defect Contractor shall promptly, without cost to Owner and in accordance with Owner's written instructions:
  - 1. correct the defective repairs to the Site or such adjacent areas;
  - 2. correct such defective Work;
  - 3. remove the defective Work from the Project and replace it with Work that is not defective, if the defective Work has been rejected by Owner, and
  - 4. satisfactorily correct or repair or remove and replace any damage to other Work, to the work of others, or to other land or areas resulting from the corrective measures.
- B. Owner shall give written notice that such Work or repairs is defective. If such notice is given within such 60 days but after the end of the correction period, the notice will be deemed a notice of defective Work under Paragraph 7.17.B.
- C. If, after receipt of a notice of defect within 60 days and within the correction period, Contractor does not promptly comply with the terms of Owner's written instructions, or in an emergency where delay would cause serious risk of loss or damage, Owner may have the

defective Work corrected or repaired or may have the rejected Work removed and replaced. Contractor shall pay all costs, losses, and damages (including but not limited to all fees and charges of engineers, architects, attorneys, and other professionals and all court or arbitration or other dispute resolution costs) arising out of or relating to such correction or repair or such removal and replacement (including but not limited to all costs of repair or replacement of work of others). Contractor's failure to pay such costs, losses, and damages within 10 days of invoice from Owner will be deemed the start of an event giving rise to a Claim under Paragraph 12.01.B, such that any related Claim must be brought within 30 days of the failure to pay.

- D. In special circumstances where a particular item of equipment is placed in continuous service before Substantial Completion of all the Work, the correction period for that item may start to run from an earlier date if so provided in the Specifications.
- E. Where defective Work (and damage to other Work resulting therefrom) has been corrected or removed and replaced under this paragraph, the correction period hereunder with respect to such Work will be extended for an additional period of one year after such correction or removal and replacement has been satisfactorily completed.
- F. Contractor's obligations under this paragraph are in addition to all other obligations and warranties. The provisions of this paragraph are not to be construed as a substitute for, or a waiver of, the provisions of any applicable statute of limitation or repose.

## **ARTICLE 16—SUSPENSION OF WORK AND TERMINATION**

### **16.01 *Owner May Suspend Work***

- A. At any time and without cause, Owner may suspend the Work or any portion thereof for a period of not more than 90 consecutive days by written notice to Contractor and Engineer. Such notice will fix the date on which Work will be resumed. Contractor shall resume the Work on the date so fixed. Contractor shall be entitled to an adjustment in the Contract Price or an extension of the Contract Times directly attributable to any such suspension. Any Change Proposal seeking such adjustments must be submitted no later than 30 days after the date fixed for resumption of Work.

### **16.02 *Owner May Terminate for Cause***

- A. The occurrence of any one or more of the following events will constitute a default by Contractor and justify termination for cause:
  - 1. Contractor's persistent failure to perform the Work in accordance with the Contract Documents (including, but not limited to, failure to supply sufficient skilled workers or suitable materials or equipment, or failure to adhere to the Progress Schedule);
  - 2. Failure of Contractor to perform or otherwise to comply with a material term of the Contract Documents;
  - 3. Contractor's disregard of Laws or Regulations of any public body having jurisdiction; or
  - 4. Contractor's repeated disregard of the authority of Owner or Engineer.

- B. If one or more of the events identified in Paragraph 16.02.A occurs, then after giving Contractor (and any surety) 10 days' written notice that Owner is considering a declaration that Contractor is in default and termination of the Contract, Owner may proceed to:
  - 1. declare Contractor to be in default, and give Contractor (and any surety) written notice that the Contract is terminated; and
  - 2. enforce the rights available to Owner under any applicable performance bond.
- C. Subject to the terms and operation of any applicable performance bond, if Owner has terminated the Contract for cause, Owner may exclude Contractor from the Site, take possession of the Work, incorporate in the Work all materials and equipment stored at the Site or for which Owner has paid Contractor but which are stored elsewhere, and complete the Work as Owner may deem expedient.
- D. Owner may not proceed with termination of the Contract under Paragraph 16.02.B if Contractor within 7 days of receipt of notice of intent to terminate begins to correct its failure to perform and proceeds diligently to cure such failure.
- E. If Owner proceeds as provided in Paragraph 16.02.B, Contractor shall not be entitled to receive any further payment until the Work is completed. If the unpaid balance of the Contract Price exceeds the cost to complete the Work, including all related claims, costs, losses, and damages (including but not limited to all fees and charges of engineers, architects, attorneys, and other professionals) sustained by Owner, such excess will be paid to Contractor. If the cost to complete the Work including such related claims, costs, losses, and damages exceeds such unpaid balance, Contractor shall pay the difference to Owner. Such claims, costs, losses, and damages incurred by Owner will be reviewed by Engineer as to their reasonableness and, when so approved by Engineer, incorporated in a Change Order. When exercising any rights or remedies under this paragraph, Owner shall not be required to obtain the lowest price for the Work performed.
- F. Where Contractor's services have been so terminated by Owner, the termination will not affect any rights or remedies of Owner against Contractor then existing or which may thereafter accrue, or any rights or remedies of Owner against Contractor or any surety under any payment bond or performance bond. Any retention or payment of money due Contractor by Owner will not release Contractor from liability.
- G. If and to the extent that Contractor has provided a performance bond under the provisions of Paragraph 6.01.A, the provisions of that bond will govern over any inconsistent provisions of Paragraphs 16.02.B and 16.02.D.

#### 16.03 *Owner May Terminate for Convenience*

- A. Upon 7 days' written notice to Contractor and Engineer, Owner may, without cause and without prejudice to any other right or remedy of Owner, terminate the Contract. In such case, Contractor shall be paid for (without duplication of any items):
  - 1. completed and acceptable Work executed in accordance with the Contract Documents prior to the effective date of termination, including fair and reasonable sums for overhead and profit on such Work;
  - 2. expenses sustained prior to the effective date of termination in performing services and furnishing labor, materials, or equipment as required by the Contract Documents in

connection with uncompleted Work, plus fair and reasonable sums for overhead and profit on such expenses; and

3. other reasonable expenses directly attributable to termination, including costs incurred to prepare a termination for convenience cost proposal.
- B. Contractor shall not be paid for any loss of anticipated profits or revenue, post-termination overhead costs, or other economic loss arising out of or resulting from such termination.

**16.04 Contractor May Stop Work or Terminate**

- A. If, through no act or fault of Contractor, (1) the Work is suspended for more than 90 consecutive days by Owner or under an order of court or other public authority, or (2) Engineer fails to act on any Application for Payment within 30 days after it is submitted, or (3) Owner fails to pay the Contractor as provided by Paragraph 15.01.D, then Contractor may, upon 7 days' written notice to Owner and Engineer, and provided Owner or Engineer do not remedy such suspension or failure within that time, terminate the contract and recover from Owner payment on the same terms as provided in Paragraph 16.03.
- B. In lieu of terminating the Contract and without prejudice to any other right or remedy, if Engineer has failed to act on an Application for Payment within 30 days after it is submitted, or Owner has failed to pay the Contractor as provided by Paragraph 15.01.D, Contractor may, 7 days after written notice to Owner and Engineer, stop the Work until payment is made of all such amounts due Contractor, including interest thereon. The provisions of this paragraph are not intended to preclude Contractor from submitting a Change Proposal for an adjustment in Contract Price or Contract Times or otherwise for expenses or damage directly attributable to Contractor's stopping the Work as permitted by this paragraph.

**ARTICLE 17—FINAL RESOLUTION OF DISPUTES**

**17.01 Methods and Procedures**

- A. *Disputes Subject to Final Resolution:* The following disputed matters are subject to final resolution under the provisions of this article:
1. A timely appeal of an approval in part and denial in part of a Claim, or of a denial in full, pursuant to Article 12; and
  2. Disputes between Owner and Contractor concerning the Work, or obligations under the Contract Documents, that arise after final payment has been made.
- B. *Final Resolution of Disputes:* For any dispute subject to resolution under this article, Owner or Contractor may:
1. elect in writing to invoke the dispute resolution process provided for in the Supplementary Conditions;
  2. agree with the other party to submit the dispute to another dispute resolution process; or
  3. if no dispute resolution process is provided for in the Supplementary Conditions or mutually agreed to, give written notice to the other party of the intent to submit the dispute to a court of competent jurisdiction.

## ARTICLE 18—MISCELLANEOUS

### 18.01 *Giving Notice*

- A. Whenever any provision of the Contract requires the giving of written notice to Owner, Engineer, or Contractor, it will be deemed to have been validly given only if delivered:
1. in person, by a commercial courier service or otherwise, to the recipient's place of business;
  2. by registered or certified mail, postage prepaid, to the recipient's place of business; or
  3. by e-mail to the recipient.

### 18.02 *Computation of Times*

- A. When any period of time is referred to in the Contract by days, it will be computed to exclude the first and include the last day of such period. If the last day of any such period falls on a Saturday or Sunday or on a day made a legal holiday by the law of the applicable jurisdiction, such day will be omitted from the computation.

### 18.03 *Cumulative Remedies*

- A. The duties and obligations imposed by these General Conditions and the rights and remedies available hereunder to the parties hereto are in addition to, and are not to be construed in any way as a limitation of, any rights and remedies available to any or all of them which are otherwise imposed or available by Laws or Regulations, by special warranty or guarantee, or by other provisions of the Contract. The provisions of this paragraph will be as effective as if repeated specifically in the Contract Documents in connection with each particular duty, obligation, right, and remedy to which they apply.

### 18.04 *Limitation of Damages*

- A. With respect to any and all Change Proposals, Claims, disputes subject to final resolution, and other matters at issue, neither Owner nor Engineer, nor any of their officers, directors, members, partners, employees, agents, consultants, or subcontractors, shall be liable to Contractor for any claims, costs, losses, or damages sustained by Contractor on or in connection with any other project or anticipated project.

### 18.05 *No Waiver*

- A. A party's non-enforcement of any provision will not constitute a waiver of that provision, nor will it affect the enforceability of that provision or of the remainder of this Contract.

### 18.06 *Survival of Obligations*

- A. All representations, indemnifications, warranties, and guarantees made in, required by, or given in accordance with the Contract, as well as all continuing obligations indicated in the Contract, will survive final payment, completion, and acceptance of the Work or termination of the Contract or of the services of Contractor.

### 18.07 *Controlling Law*

- A. This Contract is to be governed by the law of the state in which the Project is located.

18.08 *Assignment of Contract*

- A. Unless expressly agreed to elsewhere in the Contract, no assignment by a party to this Contract of any rights under or interests in the Contract will be binding on the other party without the written consent of the party sought to be bound; and, specifically but without limitation, money that may become due and money that is due may not be assigned without such consent (except to the extent that the effect of this restriction may be limited by law), and unless specifically stated to the contrary in any written consent to an assignment, no assignment will release or discharge the assignor from any duty or responsibility under the Contract.

18.09 *Successors and Assigns*

- A. Owner and Contractor each binds itself, its successors, assigns, and legal representatives to the other party hereto, its successors, assigns, and legal representatives in respect to all covenants, agreements, and obligations contained in the Contract Documents.

18.10 *Headings*

- A. Article and paragraph headings are inserted for convenience only and do not constitute parts of these General Conditions.



**SUPPLEMENTARY CONDITIONS**  
**STATE OF TENNESSEE**

1. Subsurface and Physical Conditions (Article 5.03)

As provided by Article 5.03 (page 15) of the General Conditions, subsurface conditions are unknown unless a Geotechnical Report is included at the end of Section 1 of the Detailed Specifications.

2. Hazardous Environmental Condition at Site (Article 5.06)

Neither the Owner nor the Engineer is aware of any hazardous environmental conditions on this project, however no specific examinations have been performed unless a report of such conditions is included in Section 1 of the Detailed Specifications.

3. Safety and Protection (Article 7.13)

Article 7.13 G refers to an Owner Safety Program, if any. If such program is known to exist to the Engineer, it will be identified in Section 1 of the Detailed Specifications.

4. Coordination (Article 8.02)

Section 1 of the Detailed Specifications and/or the Plans will show any other contracts or contractors which will interface with this work.

5. Progress Payments (Article 15.01)

Article 15.01 (page 61) is hereby amended to allow the Owner 30 days after receipt of the Engineer's approved Application for Payment (also known as Pay Request) in order to make payment to the Contractor.

Add the following as Article 15.01 B.5:

The Contractor affirms by the submission of the second Application for Payment (Pay Request) that the Contractor is discharging all financial obligations pertaining to this Contract in the customary business manner. Before final payment, as per Article 15.06, is made, the Contractor will be required to furnish an affidavit that all financial and other obligations related to this project have been satisfied listing any exceptions.

6. Investment of Retainage

As provided by TCA 66-11-144, the Owner will establish an interest-bearing escrow account for all contracts whose initial value exceeds \$500,000. All interest earned on the funds deposited in said account together with the principal thereof shall be paid to the Contractor upon acceptance of the work by written approval of the Engineer.

7. Listing of the Duties, Responsibilities and Limitations of Authority of the Resident Project Representative

A copy of this document as it appears in the Owner-Engineer Agreement is attached to these Supplementary Conditions.

8. Insurance Requirements

See Instructions to Bidders, Paragraphs 13, 14, 15, 16, and 17.

\*\*\*\*\*

## State and Local Fiscal Recovery Funds (SLRF) Supplemental Conditions for Contracts

### Equal Employment Opportunity

Any contract that uses federal funds to pay for construction work is a “federally assisted construction contract” and must include the equal opportunity clause found in 2 C.F.R. Part 200, unless otherwise stated in 41 C.F.R. Part 60. This contract provision is required for all procurements that meet the definition of a “federally assisted construction contract.”

During the performance of this contract, the contractor agrees as follows:

- (1) The contractor will not discriminate against any employee or applicant for employment because of race, color, religion, sex, sexual orientation, gender identity, or national origin. The contractor will take affirmative action to ensure that applicants are employed, and that employees are treated during employment without regard to their race, color, religion, sex, sexual orientation, gender identity, or national origin. Such action shall include, but not be limited to the following: Employment, upgrading, demotion, or transfer; recruitment or recruitment advertising; layoff or termination; rates of pay or other forms of compensation; and selection for training, including apprenticeship. The contractor agrees to post in conspicuous places, available to employees and applicants for employment, notices to be provided setting forth the provisions of this nondiscrimination clause.
- (2) The contractor will, in all solicitations or advertisements for employees placed by or on behalf of the contractor, state that all qualified applicants will receive consideration for employment without regard to race, color, religion, sex, sexual orientation, gender identity, or national origin.
- (3) The contractor will not discharge or in any other manner discriminate against any employee or applicant for employment because such employee or applicant has inquired about, discussed, or disclosed the compensation of the employee or applicant or another employee or applicant. This provision shall not apply to instances in which an employee who has access to the compensation information of other employees or applicants as a part of such employee's essential job functions discloses the compensation of such other employees or applicants to individuals who do not otherwise have access to such information, unless such disclosure is in response to a formal complaint or charge, in furtherance of an investigation, proceeding, hearing, or action, including an investigation conducted by the employer, or is consistent with the contractor's legal duty to furnish information.
- (4) The contractor will send to each labor union or representative of workers with which he has a collective bargaining agreement or other contract or understanding, a notice to be provided advising the said labor union or workers' representatives of the contractor's commitments under this section, and shall post copies of the notice in conspicuous places available to employees and

These Supplemental Conditions are recommended by the Tennessee Department of Environment and Conservation for projects funded through under the American Rescue Plan (ARP) State and Local Fiscal Recovery Fund (SLFRF). If the information is reproduced or conflicts with other sections of this Bid Manual or the Contract, the more stringent requirement applies.

applicants for employment.

- (5) The contractor will comply with all provisions of Executive Order 11246 of September 24, 1965, and of the rules, regulations, and relevant orders of the Secretary of Labor.
- (6) The contractor will furnish all information and reports required by Executive Order 11246 of September 24, 1965, and by rules, regulations, and orders of the Secretary of Labor, or pursuant thereto, and will permit access to his books, records, and accounts by the administering agency and the Secretary of Labor for purposes of investigation to ascertain compliance with such rules, regulations, and orders.
- (7) In the event of the contractor's noncompliance with the nondiscrimination clauses of this contract or with any of the said rules, regulations, or orders, this contract may be canceled, terminated, or suspended in whole or in part and the contractor may be declared ineligible for further Government contracts or federally assisted construction contracts in accordance with procedures authorized in Executive Order 11246 of September 24, 1965, and such other sanctions may be imposed and remedies invoked as provided in Executive Order 11246 of September 24, 1965, or by rule, regulation, or order of the Secretary of Labor, or as otherwise provided by law. (8) The contractor will include the portion of the sentence immediately preceding paragraph (1) and the provisions of paragraphs (1) through
- (8) in every subcontract or purchase order unless exempted by rules, regulations, or orders of the Secretary of Labor issued pursuant to section 204 of Executive Order 11246 of September 24, 1965, so that such provisions will be binding upon each subcontractor or vendor. The contractor will take such action with respect to any subcontract or purchase order as the administering agency may direct as a means of enforcing such provisions, including sanctions for noncompliance:

Provided, however, that in the event a contractor becomes involved in, or is threatened with, litigation with a subcontractor or vendor as a result of such direction by the administering agency, the contractor may request the United States to enter into such litigation to protect the interests of the United States.

The applicant further agrees that it will be bound by the above equal opportunity clause with respect to its own employment practices when it participates in federally assisted construction work: Provided, that if the applicant so participating is a State or local government, the above equal opportunity clause is not applicable to any agency, instrumentality or subdivision of such government which does not participate in work on or under the contract.

The applicant agrees that it will assist and cooperate actively with the administering agency and the Secretary of Labor in obtaining the compliance of contractors and subcontractors with the equal opportunity clause and the rules, regulations, and relevant orders of the Secretary of Labor, that it will furnish the administering agency and the Secretary of Labor such information as they may require for the supervision of such compliance, and that it will otherwise assist the administering agency in the discharge of the agency's primary responsibility for securing compliance.

The applicant further agrees that it will refrain from entering into any contract or contract modification subject to Executive Order 11246 of September 24, 1965, with a contractor debarred from, or who has not demonstrated eligibility for, Government contracts and federally assisted construction contracts pursuant to the Executive Order and will carry out such sanctions and penalties for violation of the equal opportunity clause

These Supplemental Conditions are recommended by the Tennessee Department of Environment and Conservation for projects funded through under the American Rescue Plan (ARP) State and Local Fiscal Recovery Fund (SLFRF). If the information is reproduced or conflicts with other sections of this Bid Manual or the Contract, the more stringent requirement applies.

as may be imposed upon contractors and subcontractors by the administering agency or the Secretary of Labor pursuant to Part II, Subpart D of the Executive Order. In addition, the applicant agrees that if it fails or refuses to comply with these undertakings, the administering agency may take any or all of the following actions: Cancel, terminate, or suspend in whole or in part this grant (contract, loan, insurance, guarantee); refrain from extending any further assistance to the applicant under the program with respect to which the failure or refund occurred until satisfactory assurance of future compliance has been received from such applicant; and refer the case to the Department of Justice for appropriate legal proceedings.

#### Davis-Bacon Act

U.S. Treasury exercised its federal authority outlining the requirements for water infrastructure projects executed using ARP funds. Therefore, the requirements for prevailing wages and rates slightly differs from the standards of Davis-Bacon. Individual projects less than \$10 million dollars are not required to provide certification that prevailing wages and rates were followed. Individual projects of \$10 million dollars or more require certification like Davis-Bacon and are outlined below. Please note that any project using other funding sources, like Community Development Block Grants or SRF loans, are subject to requirements for those programs. When combining funding sources on a single and complete project or phase, other funding program requirements may trump the requirements for the use of ARP funds. We recommend Grantees and Project Owners discuss project requirements with TDEC when leveraging ARP funds with other funding programs to ensure all applicable rules and regulations are followed.

#### **Individual Water Infrastructure Projects of \$10 million dollars or more**

- (1) A recipient may provide a certification that, for the relevant project, all laborers and mechanics employed by contractors and subcontractors in the performance of such project are paid wages at rates not less than those prevailing, as determined by the U.S. Secretary of Labor in accordance with subchapter IV of chapter 31 of title 40, United States Code (commonly known as the “Davis-Bacon Act”), for the corresponding classes of laborers and mechanics employed on projects of a character similar to the contract work in the civil subdivision of the State (or the District of Columbia) in which the work is to be performed, or by the appropriate State entity pursuant to a corollary State prevailing-wage-in-construction law (commonly known as “baby Davis-Bacon Acts”). If such certification is not provided, a recipient must provide a project employment and local impact report detailing:
  - a. The number of employees of contractors and sub-contractors working on the project;
  - b. The number of employees on the project hired directly and hired through a third party;
  - c. The wages and benefits of workers on the project by classification; and
  - d. Whether those wages are at rates less than those prevailing. 19 Recipients must maintain sufficient records to substantiate this information upon request.
  
- (2) A recipient may provide a certification that a project includes a project labor agreement, meaning a pre-hire collective bargaining agreement consistent with section 8(f) of the National Labor Relations Act (29 U.S.C. 158(f)). If the recipient does not provide such certification, the recipient must provide a project workforce continuity plan, detailing:
  - a. How the recipient will ensure the project has ready access to a sufficient supply of appropriately skilled and unskilled labor to ensure high-quality construction throughout the life of the project, including a description of any required professional certifications and/or in-house training;
  - b. How the recipient will minimize risks of labor disputes and disruptions that would jeopardize timeliness and cost-effectiveness of the project;

These Supplemental Conditions are recommended by the Tennessee Department of Environment and Conservation for projects funded through under the American Rescue Plan (ARP) State and Local Fiscal Recovery Fund (SLFRF). If the information is reproduced or conflicts with other sections of this Bid Manual or the Contract, the more stringent requirement applies.

- c. How the recipient will provide a safe and healthy workplace that avoids delays and costs associated with workplace illnesses, injuries, and fatalities, including descriptions of safety training, certification, and/or licensure requirements for all relevant workers (e.g., OSHA 10, OSHA 30);
  - d. Whether workers on the project will receive wages and benefits that will secure an appropriately skilled workforce in the context of the local or regional labor market; and
  - e. Whether the project has completed a project labor agreement.
- (3) Whether the project prioritizes local hires.
- (4) Whether the project has a Community Benefit Agreement, with a description of any such agreement.
- a. All transactions regarding this contract shall be done in compliance with the Davis-Bacon Act (40 U.S.C. 3141- 3144, and 3146-3148) and the requirements of 29C.F.R. pt. 5 as may be applicable. The contractor shall comply with 40 U.S.C. 3141-3144, and 3146-3148 and the requirements of 29 C.F.R. pt. 5 as applicable.
  - b. Contractors are required to pay wages to laborers and mechanics at a rate not less than the prevailing wages specified in a wage determination made by the Secretary of Labor.
  - c. Additionally, contractors are required to pay wages not less than once a week.

#### Copeland Anti-Kickback Act

The Copeland "Anti-Kickback" Act prohibits workers on construction contracts from giving up wages that they are owed. This requirement applies to all contracts for construction or repair work above \$2,000 in situations where the Davis-Bacon Act also applies.

- a. Contractor. The contractor shall comply with 18 U.S.C. § 874, 40 U.S.C. § 3145, and the requirements of 29 C.F.R. pt. 3 as may be applicable, which are incorporated by reference into this contract.
- b. Subcontracts. The contractor or subcontractor shall insert in any subcontracts the clause above and a clause requiring the subcontractors to include these clauses in any lower tier subcontracts. The prime contractor shall be responsible for the compliance by any subcontractor or lower tier subcontractor with all of these contract clauses.
- c. Breach. A breach of the contract clauses above may be grounds for termination of the contract, and for debarment as a contractor and subcontractor as provided in 29 C.F.R. § 5.12."

#### Contract Work Hours and Safety Standards Act

Where applicable, all contracts awarded by the non-Federal entity in excess of \$100,000 that involve the employment of mechanics or laborers must include a provision for compliance with 40 U.S.C. §§ 3702 and 3704, as supplemented by Department of Labor regulations at 29 C.F.R. Part 5. See 2 C.F.R. Part 200, Appendix II(E). Each contractor must be required to compute the wages of every mechanic and laborer on the basis of a standard work week of 40 hours.

#### **Compliance with the Contract Work Hours and Safety Standards Act.**

- (1) Overtime requirements. No contractor or subcontractor contracting for any part of the contract work which may require or involve the employment of laborers or mechanics shall require or permit any such laborer or mechanic in any workweek in which he or she is employed on such work to work in excess of forty hours in such workweek unless such laborer or mechanic receives compensation at a rate not less than one and one-half times the basic rate of pay for all hours

These Supplemental Conditions are recommended by the Tennessee Department of Environment and Conservation for projects funded through under the American Rescue Plan (ARP) State and Local Fiscal Recovery Fund (SLFRF). If the information is reproduced or conflicts with other sections of this Bid Manual or the Contract, the more stringent requirement applies.

worked in excess of forty hours in such workweek.

- (2) Violation; liability for unpaid wages; liquidated damages. In the event of any violation of the clause set forth in paragraph (b)(1) of this section the contractor and any subcontractor responsible therefor shall be liable for the unpaid wages. In addition, such contractor and subcontractor shall be liable to the United States (in the case of work done under contract for the District of Columbia or a territory, to such District or to such territory), for liquidated damages. Such liquidated damages shall be computed with respect to each individual laborer or mechanic, including watchmen and guards, employed in violation of the clause set forth in paragraph (b)(1) of this section, in the t \$27 for each calendar day on which such individual was required or permitted to work in excess of the standard workweek of forty hours without payment of the overtime wages required by the clause set forth in paragraph (b)(1) of this section.
- (3) Withholding for unpaid wages and liquidated damages. The (write in the name of the Federal agency or the loan or grant recipient) shall upon its own action or upon written request of an authorized representative of the Department of Labor withhold or cause to be withheld, from any moneys payable on account of work performed by the contractor or subcontractor under any such contract or any other Federal contract with the same prime contractor, or any other federally-assisted contract subject to the Contract Work Hours and Safety Standards Act, which is held by the same prime contractor, such sums as may be determined to be necessary to satisfy any liabilities of such contractor or subcontractor for unpaid wages and liquidated damages as provided in the clause set forth in paragraph (b)(2) of this section.
- (4) Subcontracts. The contractor or subcontractor shall insert in any subcontracts the clauses set forth in paragraph (b)(1) through (4) of this section and also a clause requiring the subcontractors to include these clauses in any lower tier subcontracts. The prime contractor shall be responsible for compliance by any subcontractor or lower tier subcontractor with the clauses set forth in paragraphs (b)(1) through (4) of this section.

#### Clean Air Act and Federal Water Pollution Control Act

For contracts over \$150,000, contracts must contain a provision requiring contractors to comply with the Clean Air Act and the Federal Water Pollution Control Act. If applicable, contracts must contain a provision that requires the contractor to agree to comply with all applicable standards, orders, or regulations issued pursuant to the Clean Air Act (42 U.S.C. §§ 7401-7671q.) and the Federal Water Pollution Control Act as amended (33 U.S.C. §§ 1251-1387).

#### Clean Air Act

- (1) The contractor agrees to comply with all applicable standards, orders or regulations issued pursuant to the Clean Air Act, as amended, 42 U.S.C. § 7401 et seq
- (2) The contractor agrees to report each violation to the (name of subrecipient entering into the contract) and understands and agrees that the (name of the subrecipient entering into the contract) will, in turn, report each violation as required to assure notification to Treasury, and the appropriate Environmental Protection Agency Regional Office.
- (3) The contractor agrees to include these requirements in each subcontract exceeding \$150,000

These Supplemental Conditions are recommended by the Tennessee Department of Environment and Conservation for projects funded through under the American Rescue Plan (ARP) State and Local Fiscal Recovery Fund (SLFRF). If the information is reproduced or conflicts with other sections of this Bid Manual or the Contract, the more stringent requirement applies.

### **Federal Water Pollution Control Act**

- (1) The contractor agrees to comply with all applicable standards, orders, or regulations issued pursuant to the Federal Water Pollution Control Act, as amended, 33 U.S.C. 1251 ets eq.
- (2) The contractor agrees to report each violation to the (name of the subrecipient entering into the contract) and understands and agrees that the (name of the subrecipient entering into the contract) will, in turn, report each violation as required to assure notification to the Treasury, and the appropriate Environmental Protection Agency Regional Office.
- (3) The contractor agrees to include these requirements in each subcontract exceeding \$150,000

### **Debarment and Suspension**

Non-federal entities, contractors and subcontractors are subject to debarment and suspension regulations. These regulations restrict awards, subawards, and contracts with certain parties that are debarred, suspended, or otherwise excluded from or ineligible for participation in Federal assistance programs and activities. In general, an “excluded” party cannot receive a Federal grant award or a contract within the meaning of a “covered transaction,” to include subawards and subcontracts. The debarment and suspension clause is required for all contracts and subcontracts for \$25,000 or more, all contracts that require the consent of an official of a federal agency, and all contracts for federally required audit services.

### **Suspension and Debarment**

- (1) This contract is a covered transaction for purposes of 2 C.F.R. pt. 180 and 2 C.F.R. pt. 3000. As such, the contractor is required to verify that none of the contractor’s principals (defined at 2 C.F.R. § 180.995) or its affiliates (defined at 2 C.F.R. § 180.905) are excluded (defined at 2 C.F.R. § 180.940) or disqualified (defined at 2 C.F.R. § 180.935).
- (2) The contractor must comply with 2 C.F.R. pt. 180, subpart C and 2 C.F.R. pt. 3000, subpart C, and must include a requirement to comply with these regulations in any lower tier covered transaction it enters into.
- (3) This certification is a material representation of fact relied upon by (insert name of recipient/subrecipient/applicant). If it is later determined that the contractor did not comply with 2 C.F.R. pt. 180, subpart C and 2 C.F.R. pt. 3000, subpart C, in addition to remedies available to (insert name of recipient/subrecipient/applicant), the Federal Government may pursue available remedies, including but not limited to suspension and/or debarment.
- (4) The bidder or proposer agrees to comply with the requirements of 2 C.F.R. pt. 180, subpart C and 2 C.F.R. pt. 3000, subpart C while this offer is valid and throughout the period of any contract that may arise from this offer. The bidder or proposer further agrees to include a provision requiring such compliance in its lower tier covered transactions.

### **Byrd Anti-Lobbying Amendment**

Contractors that apply or bid for a contract of \$100,000 or more under a federal grant must file the required certification. This is also applicable to subcontractors of more than \$100,000, must include a contract provision prohibiting the use of federal appropriated funds to influence officers or employees of the federal government. Contractors that apply or bid for a contract for more than \$100,000 must also file the required certification regarding lobbying.

Byrd Anti-Lobbying Amendment, 31 U.S.C. § 1352

These Supplemental Conditions are recommended by the Tennessee Department of Environment and Conservation for projects funded through under the American Rescue Plan (ARP) State and Local Fiscal Recovery Fund (SLFRF). If the information is reproduced or conflicts with other sections of this Bid Manual or the Contract, the more stringent requirement applies.



Contractors who apply or bid for an award of \$100,000 or more shall file the required certification. Each tier certifies to the tier above that it will not and has not used Federal appropriated funds to pay any person or organization for influencing or attempting to influence an officer or employee of any agency, a Member of Congress, officer or employee of Congress, or an employee of a Member of Congress in connection with obtaining any Federal contract, grant, or any other award covered by 31 U.S.C. § 1352. Each tier shall also disclose any lobbying with non-Federal funds that takes place in connection with obtaining any Federal award. Such disclosures are forwarded from tier to tier up to the recipient who in turn will forward the certification(s) to the awarding agency.

#### Procurement of Recovered Materials

A non-Federal entity that is a state agency or agency of a political subdivision of a state and its contractors must comply with section 6002 of the Solid Waste Disposal Act, as amended by the Resource Conservation and Recovery Act. The requirements of Section 6002 include procuring only items designated in guidelines of the Environmental Protection Agency (EPA) at 40 CFR part 247 that contain the highest percentage of recovered materials practicable, consistent with maintaining a satisfactory level of competition, where the purchase price of the item exceeds \$10,000 or the value of the quantity acquired during the preceding fiscal year exceeded \$10,000; procuring solid waste management services in a manner that maximizes energy and resource recovery; and establishing an affirmative procurement program for procurement of recovered materials identified in the EPA guidelines.

“In the performance of this contract, the Contractor shall make maximum use of products containing recovered materials that are EPA-designated items unless the product cannot be acquired competitively within a timeframe providing for compliance with the contract performance schedule; meeting contract performance requirements; or at a reasonable price. Information about this requirement, along with the list of EPA-designated items, is available at [EPA's Comprehensive Procurement Guidelines webpage](#).

The Contractor also agrees to comply with all other applicable requirements of Section 6002 of the Solid Waste Disposal Act.”

#### Domestic Preference for Procurement

As appropriate, and to the extent consistent with law, NFEs should, to the greatest extent practicable under a federal award, provide a preference for the purchase, acquisition, or use of goods, products or materials produced in the United States. This includes, but is not limited to, iron, aluminum, steel, cement, and other manufactured products.

“Domestic Preference for Procurements

As appropriate, and to the extent consistent with law, the contractor should, to the greatest extent practicable, provide a preference for the purchase, acquisition, or use of goods, products, or materials produced in the United States. This includes, but is not limited to iron, aluminum, steel, cement, and other manufactured products.

For purposes of this clause:

These Supplemental Conditions are recommended by the Tennessee Department of Environment and Conservation for projects funded through under the American Rescue Plan (ARP) State and Local Fiscal Recovery Fund (SLFRF). If the information is reproduced or conflicts with other sections of this Bid Manual or the Contract, the more stringent requirement applies.

Produced in the United States means, for iron and steel products, that all manufacturing processes, from the initial melting stage through the application of coatings, occurred in the United States. Manufactured products mean items and construction materials composed in whole or in part of non-ferrous metals such as aluminum; plastics and polymer-based products such as polyvinyl chloride pipe; aggregates such as concrete; glass, including optical fiber; and lumber.”

These Supplemental Conditions are recommended by the Tennessee Department of Environment and Conservation for projects funded through under the American Rescue Plan (ARP) State and Local Fiscal Recovery Fund (SLFRF). If the information is reproduced or conflicts with other sections of this Bid Manual or the Contract, the more stringent requirement applies.

### Access to Records

NFEs and their contractors and subcontractors must give the Department of Treasury and other authorized representatives access to records associated with their awards during the federally required record retention period and as long as the records are retained.

The following access to records requirements apply to this contract:

(1) The Contractor agrees to provide (insert name of state agency or local or Indian tribal government), (insert name of recipient), Treasury, the Comptroller General of the United States, or any of their authorized representatives access to any books, documents, papers, and records of the Contractor which are directly pertinent to this contract for the purposes of making audits, examinations, excerpts, and transcriptions.

(2) The Contractor agrees to permit any of the foregoing parties to reproduce by any means whatsoever or to copy excerpts and transcriptions as reasonably needed.

(3) The Contractor agrees to provide the Treasury or authorized representatives access to construction or other work sites pertaining to the work being completed under the contract.

### Contract Changes or Modifications

To be eligible for ARP SLFRF assistance under the non-Federal entity's Treasury grant or cooperative agreement, the cost of the change, modification, change order, or constructive change must be allowable, allocable, within the scope of its grant or cooperative agreement, and reasonable for the completion of project scope.

### Compliance with Federal Law, Regulations and Executive Orders

The recipient and its contractors are required to comply with all Federal laws, regulations, and executive orders.

"This is an acknowledgement that Treasury ARP SLFRF financial assistance will be used to fund all or a portion of the contract. The contractor will comply with all applicable Federal law, regulations, executive orders, Treasury policies, procedures, and directives."

### Program Fraud and False or Fraudulent Statements or Related Acts

Recipients must comply with the requirements of The False Claims Act (31 U.S.C. §§ 3729-3733) which prohibits the submission of false or fraudulent claims for payment to the federal government. It is that the non-Federal entity include a provision in its contract that the contractor acknowledges that 31 U.S.C. Chap. 38 (Administrative Remedies for False Claims and Statements) applies to its actions pertaining to the contract.

"The Contractor acknowledges that 31 U.S.C. Chap. 38 (Administrative Remedies for False Claims and Statements) applies to the Contractor's actions pertaining to this contract."

These Supplemental Conditions are recommended by the Tennessee Department of Environment and Conservation for projects funded through under the American Rescue Plan (ARP) State and Local Fiscal Recovery Fund (SLFRF). If the information is reproduced or conflicts with other sections of this Bid Manual or the Contract, the more stringent requirement applies.

A LISTING OF THE DUTIES, RESPONSIBILITIES AND  
LIMITATIONS OF AUTHORITY OF THE RESIDENT PROJECT REPRESENTATIVE

ENGINEER shall furnish a Resident Project Representative (RPR) to assist ENGINEER in observing performance of the Work of the Contractor.

Through more extensive on-site observations of the Work in progress and field checks of material and equipment by the RPR and assistants, ENGINEER shall endeavor to provide further protection for OWNER against defects and deficiencies in the Work but the furnishing of such services will not make ENGINEER responsible for or give ENGINEER control over construction means, methods, techniques, sequences or procedures, or for safety precautions or programs or responsibility for CONTRACTOR's failure to perform the Work in accordance with the Contract Documents.

The duties and responsibilities of the RPR are limited to those of ENGINEER in ENGINEER's agreement with the OWNER and in the construction Contract Documents, and are further limited and described as follows:

A. General

RPR is ENGINEER's agent at the site, will act as directed by and under the supervision of ENGINEER, and will confer with ENGINEER regarding RPR's actions. RPR's dealings in matters pertaining to the on-site work shall in general be with ENGINEER and CONTRACTOR keeping OWNER advised as necessary. RPR's dealings with subcontractors shall only be through or with the full knowledge and approval of CONTRACTOR. RPR shall generally communicate with OWNER with the knowledge of and under the direction of ENGINEER.

B. Duties and Responsibilities of RPR

1. Schedule: Review the progress schedule, schedule of Shop Drawings submittals and schedule of values prepared by CONTRACTOR and consult with ENGINEER concerning acceptability.
2. Conferences and Meetings: Attend meetings with CONTRACTOR, such as preconstruction conferences, progress meetings, job conferences and other project-related meetings.
3. Liaison:
  - a. Serve as ENGINEER's liaison with CONTRACTOR, working principally through CONTRACTOR's superintendent and assist in understanding the intent of the Contract Documents; and assist ENGINEER in serving as OWNER's liaison with CONTRACTOR when CONTRACTOR's operations affect OWNER's on-site operations.

- b. Assist in obtaining from OWNER additional details or information, when required for proper execution of the Work.
4. Shop Drawings and Samples:
- a. Record date of receipt of Shop Drawings and samples.
  - b. Advise ENGINEER and CONTRACTOR of the commencement of any Work requiring a Shop Drawing or sample if the submittal has not been approved by ENGINEER.
5. Review of Work, Rejection of Defective Work, Visiting Inspectors and Tests:
- a. Conduct on-site observations of the Work in progress to assist ENGINEER in determining if the Work is in general proceeding in accordance with the Contract Documents.
  - b. Report to ENGINEER whenever RPR believes that any Work is unsatisfactory, faulty or defective or does not conform to the Contract documents, or has been damaged, or does not meet the requirements of any test or approval required to be made; and advise ENGINEER of Work that RPR believes should be corrected or rejected or should be uncovered for observation, or requires special testing or approval.
  - c. Verify that tests, equipment and system startups and operating and maintenance training are conducted in the presence of appropriate personnel, and that CONTRACTOR maintains adequate records thereof; and observe, record and report to ENGINEER appropriate details relative to the test procedures and startups.
  - d. Accompany visiting inspectors representing public or other agencies having jurisdiction over the Project, record the results of these inspections and report to ENGINEER.
6. Interpretation of Contract Documents: Report to ENGINEER when clarifications and interpretations of the Contract Documents are needed and transmit to CONTRACTOR clarifications and interpretations as issued by ENGINEER.
7. Modifications: Consider and evaluate CONTRACTOR's suggestions for modifications in Drawings or Specifications and report with RPR's recommendations to ENGINEER. Transmit to CONTRACTOR decisions as issued by ENGINEER.

8. Records:
  - a. Maintain orderly files for correspondence, reports of job conferences, Shop Drawings and samples, reproductions of original Contract Documents including all Work Directive Changes, Addenda, Change Orders, Field Orders, additional Drawings issued subsequent to the execution of the Contract, ENGINEER's clarifications and interpretations of the Contract Documents, progress reports, and other Project related documents.
  - b. Keep a diary or log book, recording CONTRACTOR hours on the job site, weather conditions, data relative to questions of Work Directive Changes, Change Orders or changed conditions, list of job site visitors, daily activities, decisions, observations in general, and specific observations in more detail as in the case of observing test procedures; and send copies to ENGINEER.
  - c. Record names, addresses and telephone numbers of all CONTRACTORS, subcontractors and major suppliers of materials and equipment.
9. Reports:
  - a. Furnish ENGINEER periodic reports as required of progress of the Work and of CONTRACTOR's compliance with the progress schedule and schedule of Shop Drawing and sample submittals.
  - b. Consult with ENGINEER in advance of scheduled major tests, inspections or start of important phases of Work.
  - c. Report immediately to ENGINEER and OWNER upon the occurrence of any accident.
10. Payment Requests: Review applications for payment with CONTRACTOR for compliance with the established procedure for their submission and forward with recommendations to ENGINEER, noting particularly the relationship of the payment requested to the schedule of values, work completed and materials and equipment delivered at the site but not incorporated in the Work.
11. Certificates, Maintenance and Operation Materials: During the course of the Work, verify that certificates, maintenance and operation manuals and other data required to be assembled and furnished by CONTRACTOR are applicable to the items actually installed and in accordance with the Contract Documents, and have this material delivered to ENGINEER for review and forwarding to OWNER prior to final payment for the work.

12. Completion:

- a. Before ENGINEER issues a Notice of Substantial Completion, submit to CONTRACTOR a list of observed items requiring completion or correction.
- b. Conduct final observation in the company of ENGINEER, OWNER and CONTRACTOR and prepare a final list of items to be completed or corrected.
- c. Observe that all items on final list have been completed or corrected and make recommendations to ENGINEER concerning acceptance.

C. Limitations of Authority

Resident Project Representative:

1. Shall not authorize any deviation from the Contract Documents or substitution of materials or equipment, unless authorized by ENGINEER.
2. Shall not exceed limitations of ENGINEER's authority as set forth in the Contract Documents.
3. Shall not undertake any of the responsibilities of CONTRACTOR, subcontractors or CONTRACTOR's superintendent.
4. Shall not advise on, issue directions relative to or assume control over any aspect of the means, methods, techniques, sequences or procedures of construction unless such advice or directions are specifically required by the Contract Documents.
5. Shall not advise on, issue directions regarding or assume control over safety precautions and programs in connection with the Work.
6. Shall not accept Shop Drawing or sample submittals from anyone other than CONTRACTOR.
7. Shall not authorize OWNER to occupy the Project in whole or in part.
8. Shall not participate in specialized field or laboratory tests or inspections conducted by others except as specifically authorized by ENGINEER.

BID FORM

- An Individual   
A Partnership   
A Corporation   
A Limited Liability Corporation

Date \_\_\_\_\_

1. BID for the construction of Contract 23-01 – Summer City Road Water Relocation.

TO THE CITY OF DAYTON, TENNESSEE:

I / WE

\_\_\_\_\_  
Name of Bidder

\_\_\_\_\_  
Address of Bidder

The undersigned, as Bidder, proposes to furnish all necessary labor, machinery, tools, apparatus, materials, equipment, service and other necessary supplies, in strict accordance with the terms and conditions of the Detailed Specifications and Contract Documents bound into the PROJECT MANUAL hereto attached and the Plans referred to herein for the construction of Contract 23-01 – Summer City Road Water Relocation, and to do such other work incidental thereto as may be ordered by the Engineer, at the lump sum or unit prices listed herein.

2. The Bidder declares that he has examined the site of the work and informed himself fully in regard to all conditions pertaining to the places where the work is to be done; that he has examined the Plans, Detailed Specifications and Contract Documents for the work and has read all addenda furnished prior to the opening of bids; and that he has satisfied himself relative to the work to be performed.
3. The Bidder is required to fill in all blank spaces in the BID FORM for all Schedules. Failure to fill in all blank spaces for lump sum or unit prices in both words and figures may be grounds for declaring a bid irregular.
4. The Bidder agrees that his Bid shall not be withdrawn for a period of 90 calendar days after the scheduled closing time for receiving bids.
5. Bids shall include sales tax and all other applicable taxes, fees or licenses.



BID FORM  
4657 – March 2024

6. The lump sum or unit prices shall include all labor, materials, shoring, overhead, profit, insurance, *etc.*, to cover the finished work of the several kinds called for.
7. The Bidder understands that the Owner reserves the right to reject any or all bids and to waive any informalities in the bidding.

8. CONTRACT 23-01 – SUMMER CITY ROAD WATER RELOCATION

ITEM NUMBER	APPROXIMATE QUANTITY	DESCRIPTION WITH UNIT BID PRICE WRITTEN IN WORDS	UNIT PRICE	TOTAL PRICE
1.	Lump Sum	Connection No. 1 at Station 0+00, Line "W-1", including all tapping sleeves, valves, fittings, plugs, kickers, and all pipe required for connections to existing lines as shown on the Plans and as specified herein For _____ _____ Dollars _____ Cents, lump sum		\$ _____
2.	280 L.F.	6-inch DR 21 PVC Water Line via Open-Cut Methods, complete in place, including fittings, all excavation and bedding For _____ _____ Dollars _____ Cents, per linear foot	\$ _____	\$ _____
3.	102 L.F.	6-inch Class 350 RJDIP Water Line installed in 12-inch casing, complete in place, including fittings, all excavation and bedding For _____ _____ Dollars _____ Cents, per linear foot	\$ _____	\$ _____

8. CONTRACT 23-01 – SUMMER CITY ROAD WATER RELOCATION (cont'd)

ITEM NUMBER	APPROXIMATE QUANTITY	DESCRIPTION WITH UNIT BID PRICE WRITTEN IN WORDS	UNIT PRICE	TOTAL PRICE
4.	1,605 L.F.	4-inch DR 21 PVC Water Line via Open-Cut Methods, complete in place, including fittings, all excavation and bedding For _____ _____ Dollars _____ Cents, per linear foot	\$ _____	\$ _____
5.	120 L.F.	4-inch Class 350 RJDIP Water Line installed in 12-inch casing, complete in place, including fittings, all excavation and bedding For _____ _____ Dollars _____ Cents, per linear foot	\$ _____	\$ _____
6.	43 L.F.	2-inch DR 21 PVC Water Line via Open-Cut Methods, complete in place, including fittings, all excavation and bedding For _____ _____ Dollars _____ Cents, per linear foot	\$ _____	\$ _____

8. CONTRACT 23-01 – SUMMER CITY ROAD WATER RELOCATION (cont'd)

ITEM NUMBER	APPROXIMATE QUANTITY	DESCRIPTION WITH UNIT BID PRICE WRITTEN IN WORDS	UNIT PRICE	TOTAL PRICE
7.	202 L.F.	12-inch Steel Casing Pipe, 0.250-inch minimum wall thickness installed by Boring Methods, including all incidentals except carrier pipe For _____ _____ Dollars _____ Cents, per linear foot	\$ _____	\$ _____
8.	1 Each	6-inch Gate Valve Assembly, including valve and valve box, complete in place, as shown on the Plans and specified herein For _____ _____ Dollars _____ Cents, each	\$ _____	\$ _____
9.	6 Each	4-inch Gate Valve Assembly, including valve and valve box, complete in place, as shown on the Plans and specified herein For _____ _____ Dollars _____ Cents, each	\$ _____	\$ _____

8. CONTRACT 23-01 – SUMMER CITY ROAD WATER RELOCATION (cont'd)

ITEM NUMBER	APPROXIMATE QUANTITY	DESCRIPTION WITH UNIT BID PRICE WRITTEN IN WORDS	UNIT PRICE	TOTAL PRICE
10.	1 Each	2-inch Gate Valve Assembly, including valve and valve box, complete in place, as shown on the Plans and specified herein For _____ _____ Dollars _____ Cents, each	\$ _____	\$ _____
11.	1 Each	Manual Air Release Valve as shown on the Detail of the Plans including valve, piping, and valve box, (Stone and Class "C" concrete will be paid for at unit prices) complete in place, as shown on the Plans and specified herein For _____ _____ Dollars _____ Cents, each	\$ _____	\$ _____
12.	5 Each	3/4-inch service reconnection for residents to new water line including tapping, and installing new curb stop at new water main, fitting, meter box, yoke, and relocation of existing meter, as shown on the Plans and specified herein, complete in place For _____ _____ Dollars _____ Cents, each	\$ _____	\$ _____

8. CONTRACT 23-01 – SUMMER CITY ROAD WATER RELOCATION (cont'd)

ITEM NUMBER	APPROXIMATE QUANTITY	DESCRIPTION WITH UNIT BID PRICE WRITTEN IN WORDS	UNIT PRICE	TOTAL PRICE
13.	400 L.F.	Service piping, 3/4-inch ASTM B88, type K copper service pipe installed by bore or open-cut methods between the service connection and the meter box, including excavation, backfill, clean-up and all incidentals as shown on the Plans and specified herein, complete in place For _____  Dollars _____ Cents, per linear foot	\$ _____	\$ _____
14.	253 L.F.	2-inch Schedule 80 PVC Casing Pipe Open-Cut for Service Line Installation For _____  Dollars _____ Cents, per linear foot	\$ _____	\$ _____
15.	10 C.Y.	Class "C" Concrete for Kickers, Cradles, Collars, Anchors and Encasements For _____  Dollars _____ Cents, per cubic yard	\$ _____	\$ _____

8. CONTRACT 23-01 – SUMMER CITY ROAD WATER RELOCATION (cont'd)

ITEM NUMBER	APPROXIMATE QUANTITY	DESCRIPTION WITH UNIT BID PRICE WRITTEN IN WORDS	UNIT PRICE	TOTAL PRICE
16.	250 C.Y.	Crushed Stone (Size No. 67) for backfill of ditch under streets or where ordered by the Engineer For _____ _____ Dollars _____ Cents, per cubic yard	\$ _____	\$ _____
17.	20 C.Y.	Crushed Stone Class "A" Grade "D" compacted for Traffic Bound Surfacing and/or Base Course and/or Backfill where water lines are constructed under existing paved surfaces and where directed by the Engineer For _____ _____ Dollars _____ Cents, per cubic yard	\$ _____	\$ _____
18.	75 C.Y.	Flowable Fill for backfill under streets or where directed by the Engineer For _____ _____ Dollars _____ Cents, per cubic yard	\$ _____	\$ _____
19.	10 C.Y.	Binder Course where directed by the Engineer For _____ _____ Dollars _____ Cents, per cubic yard	\$ _____	\$ _____

8. CONTRACT 23-01 – SUMMER CITY ROAD WATER RELOCATION (cont'd)

ITEM NUMBER	APPROXIMATE QUANTITY	DESCRIPTION WITH UNIT BID PRICE WRITTEN IN WORDS	UNIT PRICE	TOTAL PRICE
20.	10 C.Y.	Asphaltic Concrete Pavement where directed by the Engineer For _____ _____ Dollars _____ Cents, per cubic yard	\$ _____	\$ _____
21.	2,200 L.F.	Silt Fence, Hay Bales, Erosion Control Socks or similar for erosion control where directed by the Engineer For _____ _____ Dollars _____ Cents, per linear foot	\$ _____	\$ _____
22.	20 S.Y.	Rip-Rap, hand placed where shown on the Plans or directed by the Engineer For _____ _____ Dollars _____ Cents, per square yard	\$ _____	\$ _____
<b>TOTAL BID FOR CONTRACT 23-01, BID FORM ITEMS 1 THROUGH 22 INCLUSIVE</b>			\$ _____	



9. Time of Commencement and Completion

The Bidder further proposes and agrees hereby to commence the work with adequate force and equipment on a date to be specified in a written order of the Engineer, and complete all work within the calendar days shown:

Within 60 consecutive calendar days

10. Liquidated Damages

The Bidder further understands that if the work is not completed within the time specified, that any additional engineering and resident construction observation costs incurred by the Owner due to the Contractor exceeding the time allowed for completion plus other damages, including the Owner's administrative cost, will be deducted on a per calendar day basis from the compensation otherwise due him in accordance with the General Conditions for each day thereafter, Sundays and holidays included, that work remains uncompleted.

One Thousand (\$1,000.00) Dollars per calendar day

11. Time Limit for Execution of Documents

The undersigned further agrees that, in case of failure on his part to execute the said Contract and the Bond(s) within fourteen (14) consecutive calendar days after written notice being given of the award of the Contract, the check or bid bond accompanying this bid and the monies payable thereon shall be paid into the funds of the City of Dayton, Tennessee as liquidated damages for such failure; otherwise the check or bid bond accompanying this BID FORM shall be returned to the undersigned.

12. Bid Guaranty

Attached hereto is a certified check on the \_\_\_\_\_  
Bank of \_\_\_\_\_ or a Bid Bond on the form  
provided for the sum of \_\_\_\_\_ Dollars (\$\_\_\_\_\_) made  
payable to the City of Dayton, Tennessee to ensure that the Contractor will  
execute the Construction Contract and the Contract Bonds.

13. Interested Parties

The undersigned, as Bidder, hereby declares that the only person or persons interested in the BID FORM as principal or principals is or are named herein, and that no person other than mentioned herein has any interest in this BID FORM or in the Contract to be entered into; that this BID FORM is made without connection with any other person, company, or parties making a bid or proposal and that it is in all respects fair and in good faith without collusion or fraud.

NAME

ADDRESS

---

---

---

---

---

---

14. Addenda

I hereby certify that I have received, read and examined the following numbered Addenda: \_\_\_\_\_, \_\_\_\_\_, \_\_\_\_\_, \_\_\_\_\_, \_\_\_\_\_, \_\_\_\_\_, \_\_\_\_\_.

15. Drug-Free Workplace Affidavit

The Drug-Free Workplace Affidavit on the following page must be satisfactorily completed in order for the bid to be considered.

16. Illegal Immigrants

The Compliance Certificate relative to Illegal Immigrants which follows must be satisfactorily completed in order for the bid to be considered.

17. Iran Divestment Act

The Statement of Compliance relative to the Iran Divestment Act which follows must be satisfactorily completed in order for the bid to be considered.

BY: \_\_\_\_\_  
Name of Bidder

\_\_\_\_\_  
Address of Bidder

\_\_\_\_\_  
Signature of Authorized Representative

\_\_\_\_\_  
Title

ATTEST (For Corporations)

\_\_\_\_\_  
(Name)

\_\_\_\_\_  
Title

\*\*\*\*\*

BID BOND

KNOW ALL MEN BY THESE PRESENTS, that we, the undersigned,  
\_\_\_\_\_ as  
Principal, and \_\_\_\_\_ as  
Surety, are hereby held and firmly bound unto the City of Dayton, Tennessee, as Owner,  
in the penal sum of:

\_\_\_\_\_ the  
payment of which, well and truly to be made, we hereby jointly and severally bind  
ourselves, our heirs, executors, administrators, successors and assigns.

Signed this \_\_\_\_\_ day of \_\_\_\_\_, 20\_\_\_\_.

The condition of the above obligation is such that whereas the Principal has  
submitted to the City of Dayton, Tennessee, a certain BID, attached hereto and made a  
part hereof to enter into Contract in writing for the construction of Water System  
Improvements, Contract 23-01 – Summer City Road Water Relocation.

NOW THEREFORE,

- (a) If said Bid shall be rejected, or in the alternate,
- (b) If said Bid shall be accepted and the Principal shall execute and deliver a  
Contract in the Form of Contract attached hereto (properly completed in  
accordance with said Bid) and shall furnish a bond for his faithful  
performance of said Contract, and for the payment of all persons  
performing labor or furnishing materials in connection therewith, and shall  
in all other respects perform the agreement created by the acceptance of  
said BID, then this obligation shall be void, otherwise the same shall  
remain in force and effect, it being expressly understood and agreed that  
the liability of the Surety for any and all claims hereunder shall, in no event,  
exceed the penal amount of this obligation as herein stated.

The Surety, for value received, hereby stipulates and agrees that the obligations  
of said Surety and its bond shall be in no way impaired or affected by any extension of  
the time within which the Owner may accept such BID; and said Surety does hereby  
waive notice of any such extension.

BID BOND  
4657 – March 2024

IN WITNESS WHEREOF, the Principal and the Surety have hereunto set their hands and seals, and such of them as are corporations have caused their corporate seals to be hereto affixed and these presents to be signed by their proper officers, the day and year first set forth above.

Principal

\_\_\_\_\_  
Firm Name

BY: \_\_\_\_\_

Signature

\_\_\_\_\_  
Printed Name

ADDRESS: \_\_\_\_\_

\_\_\_\_\_  
Seal

Surety

\_\_\_\_\_  
Firm Name

BY: \_\_\_\_\_

Signature

\_\_\_\_\_  
Printed Name

ADDRESS: \_\_\_\_\_

\_\_\_\_\_  
Seal

BID BOND  
4657 – March 2024

NOTE: A copy of the Power of Attorney of the Surety's Principal is required and the amount of the bond must not be less than five percent (5%) of the amount of bid.

Surety companies executing bonds must appear on the Treasury Department's most current list (Circular 570 as amended) and be authorized to transact business in the State where the project is located.

\*\*\*\*\*

# ACKNOWLEDGEMENT REGARDING BIDDER SAM REGISTRATION

Contractors procured directly by grantees, sub-grantees, and/or sub-recipients of American Rescue Plan Act (ARPA) funds, are required to have an active registration in the System of Award Management (SAM). This document shall be completed and submitted as part of the bid proposal.

1. By submitting this proposal, the prospective bidder certifies that it has an active registration in SAM that is not set to expire within the next 90 days.
2. By submitting this proposal, the prospective bidder certifies neither it, its principals nor affiliates, is presently debarred, suspended, proposed for debarment, declared ineligible, or voluntarily excluded from participation in this transaction by any Federal department or agency.
3. The certification in this clause is a material representation of fact upon which reliance was placed when this transaction was entered into. If it is later determined that an erroneous certification was rendered, in addition to other remedies available to the Federal Government, the Department or agency with which this transaction originated may pursue available remedies.
4. Further, the prospective bidder shall provide immediate written notice to the person to which this proposal is submitted if at any time the Participant learns that this certification was erroneous when submitted or has become erroneous by reason of changed circumstances.
5. By submitting this proposal, it is agreed that should the proposed covered transaction be entered into, the prospective bidder will not knowingly enter into any lower-tier covered transaction with a person who is debarred, suspended, declared ineligible, or voluntarily excluded from participation in this covered transaction unless authorized by the agency with which this transaction originated.
6. It is further agreed that by submitting this proposal, the prospective bidder will include Certification of Subcontractor Regarding Debarment, Suspension, Ineligibility and Voluntary Exclusion without modification, in all lower-tier covered transactions and in all solicitations for lower-tier covered transactions.

Provide the following information as detailed in the prospective bidder's SAM registration:

Entity Name \_\_\_\_\_

Address \_\_\_\_\_

City: \_\_\_\_\_ State: \_\_\_\_\_ Zip: \_\_\_\_\_

SAM Entity ID: \_\_\_\_\_ Expiration Date: \_\_\_\_\_

Active Exclusions:  Yes  No

# CERTIFICATION OF BIDDER REGARDING EQUAL EMPLOYMENT OPPORTUNITY

This certification is required pursuant to Executive Order 11246 (30 F. R. 12319-25). The implementing rules and regulations provide that any bidder or prospective contractor, or any of their proposed subcontractors, shall state as an initial part of the bid or negotiations of the contract whether it has participated in any previous contract or subcontract subject to the equal opportunity clause; and, if so, whether it has filed all compliance reports due under applicable instructions.

Where the certification indicates that the bidder has not filed a compliance report due under applicable instructions, such bidder shall be required to submit a compliance report within seven calendar days after bid opening. No contract shall be awarded unless such report is submitted.

## **Certification by Bidder**

Bidder/Firm: \_\_\_\_\_

Address: \_\_\_\_\_

City: \_\_\_\_\_ State \_\_\_\_\_ Zip \_\_\_\_\_

1. Bidder has participated in a previous contract or subcontract subject to the Equal Opportunity Clause.  Yes  No
2. Compliance reports were required to be filed in connection with such contract or subcontract.  Yes  No
3. Bidder has filed all compliance reports due under applicable instructions, including SF-100.  Yes  No  None Req.
4. Have you ever been or are you being considered for sanction due to violation of Executive Order 11246, as amended?  Yes  No

Bidder Name: \_\_\_\_\_

Title: \_\_\_\_\_

Signature: \_\_\_\_\_

Date: \_\_\_\_\_



**STATE OF TENNESSEE**  
**CERTIFICATION OF BIDDER REGARDING**  
**USE OF WOMEN/MINORITY SUBCONTRACTORS**  
***\*Construction Projects Only\****

This certification is required for the contractor to demonstrate that when subcontractors are to be used on this project, an attempt will be made to utilize women/minority owned firms.

Documentation must be on file to show who has been contacted.

- I certify that every attempt was made to utilize female/minority contractors on this project.
- I am unable to certify to the above statements. Explanation is attached.

<b>Signature of Authorized Representative</b>	<b>Date</b>
<b>Printed Name</b>	<b>Phone Number</b>
<b>Email Address</b>	<b>Address</b>





**STATE OF TENNESSEE**  
**CERTIFICATION REGARDING DEBARMENT, SUSPENSION**  
**AND OTHER RESPONSIBILITY MATTERS**

The prospective participant certifies to the best of its knowledge and belief that it and its principals:

- Are not presently debarred, suspended, proposed for debarment, declared ineligible, or voluntarily excluded from covered transactions by any Federal department or agency;
- Have not within a three-year period preceding this proposal been convicted of or had a civil judgement rendered against them for commission of fraud or a criminal offense in connection with obtaining, attempting to obtain, or performing a public (Federal, State, or local) transaction or contract under a public transaction; violation of Federal or State antitrust statutes or commission of embezzlement, theft, forgery, bribery, falsification or destruction of records, making false statements, or receiving stolen property;
- Are not presently indicted for or otherwise criminally or civilly charged by a government entity (Federal, State, or local) with commission of any of the offenses enumerated in paragraph (b) of this certification; and
- Have not within a three-year period preceding this application/proposal had one or more public transactions (Federal, State, or local) terminated for cause or default.

I understand that a false statement on this certification may be grounds for rejection of this proposal or termination of the award. In addition, under 18 USC Sec. 1001, a false statement may result in a fine of up to \$10,000 or imprisonment for up to 5 years, or both.

<b>Signature of Authorized Representative</b>	<b>Date</b>
<b>Printed Name</b>	<b>Phone Number / Email Address</b>

I am unable to certify to the above statements. Explanation is attached.

# CERTIFICATION BY PROPOSED SUBCONTRACTOR REGARDING EQUAL EMPLOYMENT OPPORTUNITY

NAME OF PRIME CONTRACTOR: \_\_\_\_\_

PROJECT NUMBER: \_\_\_\_\_

This certification is required pursuant to Executive Order 11246 (30 F. R. 12319-25). The implementing rules and regulations provide that any bidder or prospective contractor, or any of their proposed subcontractors, shall state as an initial part of the bid or negotiations of the contract whether it has participated in any previous contract or subcontract subject to the equal opportunity clause; and, if so, whether it has filed all compliance reports due under applicable instructions.

Where the certification indicates that the subcontractor has not filed a compliance report due under applicable instructions, such subcontractor shall be required to submit a compliance report before the owner approves the subcontract or permits work to begin under the subcontract.

## **SUBCONTRACTOR'S CERTIFICATION**

Subcontractor Name: \_\_\_\_\_

Address: \_\_\_\_\_

City: \_\_\_\_\_ State \_\_\_\_\_ Zip \_\_\_\_\_

1. Bidder has participated in a previous contract or subcontract subject to the Equal Opportunity Clause.  Yes  No
2. Compliance reports were required to be filed in connection with such contract or subcontract.  Yes  No
3. Bidder has filed all compliance reports due under applicable instructions, including SF-100.  Yes  No  None Req.
4. Have you ever been or are you being considered for sanction due to violation of Executive Order 11246, as amended?  Yes  No

Name: \_\_\_\_\_

Title: \_\_\_\_\_

Signature: \_\_\_\_\_

Date: \_\_\_\_\_

# CERTIFICATION OF SUBCONTRACTOR REGARDING DEBARMENT, SUSPENSION, INELIGIBILITY AND EXCLUSION

Subcontractors for projects that are funded in whole or in part by Coronavirus State and Local Fiscal Recovery Fund (SLFRF) and American Rescue Plan Act (ARPA) funds must provide information concerning the entity's debarment, suspension, ineligibility or exclusion status. This document shall be completed and provided to the prime contractor.

1. By signing and submitting this proposal, the prospective lower-tier participant certifies that neither it, its principals nor affiliates, is presently debarred, suspended, proposed for debarment, declared ineligible, or voluntarily excluded from participation in this transaction by any Federal department or agency. Further, the Participant provides the certification set out below:
2. The certification in this clause is a material representation of fact upon which reliance was placed when this transaction was entered into. If it is later determined that an erroneous certification was rendered, in addition to other remedies available to the Federal Government, the Department or agency with which this transaction originated may pursue available remedies.
3. Further, the Participant shall provide immediate written notice to the person to which this proposal is submitted if at any time the Participant learns that this certification was erroneous when submitted or has become erroneously reason of changed circumstances.
4. By submitting this document, it is agreed that should the proposed covered transaction be entered into, the Participant will not knowingly enter into any lower-tier covered transaction with a person who is debarred, suspended, declared ineligible, or voluntarily excluded from participation in this covered transaction unless authorized by the agency with which this transaction originated.

The subcontracting entity may satisfy the requirement of this document via one of the two options below:

## Option 1: SAM.gov Active Registration

Entity Name \_\_\_\_\_

Address \_\_\_\_\_

City: \_\_\_\_\_ State: \_\_\_\_\_ Zip: \_\_\_\_\_

SAM Entity ID: \_\_\_\_\_ Expiration Date: \_\_\_\_\_

Active Exclusions:  Yes  No

---

## Option 2: Signed Certification

Entity Name \_\_\_\_\_

Address \_\_\_\_\_

City: \_\_\_\_\_ State: \_\_\_\_\_ Zip: \_\_\_\_\_

Entity Representative: \_\_\_\_\_ Title: \_\_\_\_\_

Signature \_\_\_\_\_



## STATE OF TENNESSEE

### BYRD ANTI-LOBBYING AMENDMENT CERTIFICATION

Contractors who apply or bid for an award of \$100,000 or more shall file the required certification. Each tier certifies to the tier above that it will not and has not used Federal appropriated funds to pay any person or organization for influencing or attempting to influence an officer or employee of any agency, a Member of Congress, officer or employee of Congress, or an employee of a Member of Congress in connection with obtaining any Federal contract, grant, or any other award covered by 31 U.S.C. § 1352.

Each tier shall also disclose any lobbying with non-Federal funds that takes place in connection with obtaining any Federal award. Such disclosures are forwarded from tier to tier up to the recipient who in turn will forward the certification(s) to the awarding agency.

#### **APPENDIX A, 44 C.F.R. PART 18 – CERTIFICATION REGARDING LOBBYING – REQUIRED FOR CONTRACTS OVER \$100,000** *Certification for Contracts, Grants, Loans, and Cooperative Agreements*

The undersigned certifies, to the best of his or her knowledge and belief, that:

- No Federal appropriated funds have been paid or will be paid, by or on behalf of the undersigned, to any person for influencing or attempting to influence an officer or employee of an agency, a Member of Congress, an officer or employee of Congress, or an employee of a Member of Congress in connection with the awarding of any Federal contract, the making of any Federal grant, the making of any Federal loan, the entering into of any cooperative agreement, and the extension, continuation, renewal, amendment, or modification of any Federal contract, grant, loan, or cooperative agreement.
- If any funds other than Federal appropriated funds have been paid or will be paid to any person for influencing or attempting to influence an officer or employee of any agency, a Member of Congress, an officer or employee of Congress, or an employee of a Member of Congress in connection with this Federal contract, grant, loan, or cooperative agreement, the undersigned shall complete and submit Standard Form-LLL, "Disclosure Form to Report Lobbying," in accordance with its instructions.
- The undersigned shall require that the language of this certification be included in the award documents for all subawards at all tiers (including subcontracts, subgrants, and contracts under grants, loans, and cooperative agreements) and that all subrecipients shall certify and disclose accordingly.

This certification is a material representation of fact upon which reliance was placed when this transaction was made or entered into. Submission of this certification is a prerequisite for making or entering into this transaction imposed by section 1352, title 31, U.S. Code. Any person who fails to file the required certification shall be subject to a civil penalty of not less than \$10,000 and not more than \$100,000 for each such failure.

The Contractor certifies or affirms the truthfulness and accuracy of each statement of its certification and disclosure, if any. In addition, the Contractor understands and agrees that the provisions of 31 U.S.C. Chap. 38, Administrative Remedies for False Claims and Statements, apply to this certification and disclosure, if any.

<b>Signature of Authorized Representative</b>	<b>Date</b>
<b>Printed Name and Title</b>	<b>Phone Number / Email Address</b>

## DRUG-FREE WORKPLACE AFFIDAVIT

STATE OF \_\_\_\_\_

COUNTY OF \_\_\_\_\_

The undersigned, principal officer of \_\_\_\_\_, an employer of five (5) or more employees contracting with \_\_\_\_\_ government to provide construction services, hereby states under oath as follows:

1. The undersigned is a principal officer of \_\_\_\_\_ (hereinafter referred to as the "Company"), and is duly authorized to execute this Affidavit on behalf of the Company.
2. The Company submits this Affidavit pursuant to T.C.A. § 50-9-113, which requires each employer with no less than five (5) employees receiving pay who contracts with the state or any local government to provide construction services to submit an affidavit stating that such employer has a drug-free workplace program that complies with Title 50, Chapter 9, of the Tennessee Code Annotated.
3. The Company is in compliance with T.C.A. § 50-9-113.

Further affiant saith not.

\_\_\_\_\_  
Principal Officer

STATE OF \_\_\_\_\_

COUNTY OF \_\_\_\_\_

Before me personally appeared \_\_\_\_\_, with whom I am personally acquainted (or proved to me on the basis of satisfactory evidence), and who acknowledged that such person executed the foregoing affidavit for the purposes therein contained.

Witness my hand and seal at office this \_\_\_\_\_ day of \_\_\_\_\_, 20\_\_\_\_.

\_\_\_\_\_  
Notary Public

My commission expires: \_\_\_\_\_

# STATEMENT OF COMPLIANCE CERTIFICATE ILLEGAL IMMIGRANT

EACH CONTRACTOR BIDDING SHALL FILL IN AND SIGN THE FOLLOWING

Bidder Name: \_\_\_\_\_

Address: \_\_\_\_\_

City: \_\_\_\_\_ State \_\_\_\_\_ Zip \_\_\_\_\_

This is to certify that \_\_\_\_\_ have fully complied with all the requirements of T.C.A. § 12-3-309, stating:

- (1) No state governmental entity shall contract to acquire goods or services from any person who knowingly utilizes the services of illegal immigrants in the performance of a contract for goods or services entered into with a state governmental entity;
- (2) No person may contract to supply goods or services to a state governmental entity if that person knowingly utilizes the services of illegal immigrants in the performance of a contract to supply goods or services entered into with the state or a state entity.

*All Bidders for construction services on this project shall be required to submit an affidavit (by executing this compliance document) as part of their bid, that attests that such Bidder shall comply with requirements of T.C.A. § 12-3-309.*

Name: \_\_\_\_\_

Title: \_\_\_\_\_

Signature: \_\_\_\_\_

Date: \_\_\_\_\_



**STATE OF TENNESSEE  
IRAN DIVESTMENT ACT CERTIFICATION**

<b>SUBJECT CONTRACT NUMBER(S):</b>	
<b>CONTRACTOR LEGAL ENTITY NAME:</b>	
<b>EDISON SUPPLIER IDENTIFICATION NUMBER:</b>	

The Iran Divestment Act, Tenn. Code Ann. § 12-12-101 et. seq. requires a person that attempts to contract with the state, including a contract renewal or assumption, to certify at the time the bid is submitted or the contract is entered into, renewed, or assigned, that the person or the assignee is not identified on a list created pursuant to § 12-12-106.

Currently, the list is available online at the following website: <https://www.tn.gov/generalservices/procurement/central-procurement-office--cpo-/library-/public-information-library.html>

The Contractor, identified above, certifies by signature below that it is not included on the list of persons created pursuant to Tenn. Code Ann. § 12-12-106 of the Iran Divestment Act.

---

**CONTRACTOR SIGNATURE**

NOTICE: This certification MUST be signed by an individual with legal capacity to contractually bind the Contractor.

---

**PRINTED NAME AND TITLE OF SIGNATORY**

---

**DATE**





## NOTICE

Tenn. Code Ann. § 12-12-106 requires the chief procurement officer to publish, using credible information freely available to the public, a list of persons it determines engage in investment activities in Iran, as described in § 12-12-105.

For these purposes, the State intends to use the attached list of “Entities determined to be non-responsive bidders/offers pursuant to the New York State Iran Divestment Act of 2012.”

While inclusion on this list would make a person ineligible to contract with the state of Tennessee, if a person ceases its engagement in investment activities in Iran, it may be removed from the list.

If you feel as though you have been erroneously included on this list please contact the Central Procurement Office at [CPO.Website@tn.gov](mailto:CPO.Website@tn.gov).

---

## Entities determined to be non-responsive bidders/offerers pursuant to The New York State Iran Divestment Act of 2012

---

1. Ak Makina, Ltd.
2. Amona
3. Bank Markazi Iran (Central Bank of Iran)
4. Bank Mellat
5. Bank Melli Iran
6. Bank Saderat Iran
7. Bank Sepah
8. Bank Tejarat
9. China Precision Machinery Import-Export Corporation (CPMIEC)
10. ChinaOil (China National United Oil Corporation)
11. China National Offshore Oil Corporation (CNOOC)
12. China National Petroleum Corporation (CNPC)
13. Indian Oil Corporation
14. Kingdream PLC
15. Naftiran Intertrade Co. (NICO)
16. National Iranian Tanker Co. (NITC)
17. Oil and Natural Gas Corporation (ONGC)
18. Oil India, Ltd.
19. Persia International Bank
20. Petroleos de Venezuela (PDVSA Petróleo, SA)
21. PetroChina Co., Ltd.
22. Petronet LNG, Ltd.
23. Sameh Afzar Tajak Co. (SATCO)
24. Shandong FIN CNC Machine Co., Ltd.
25. Sinohydro Co., Ltd.
26. Sinopec Corp. (China Petroleum & Chemical Corporation)
27. SKS Ventures
28. SK Energy Co., Ltd.
29. Som Petrol AS
30. Unipec (China International United Petroleum & Chemicals Co., Ltd.)
31. Zhuhai Zhenrong Co.

List Date: December 4, 2023

For more information you may call: (518) 474-5988 or email: [NYSIranDivestmentAct@ogs.ny.gov](mailto:NYSIranDivestmentAct@ogs.ny.gov)



**STATE OF TENNESSEE**  
**NON-BOYCOTT OF ISRAEL CERTIFICATION**

The Bidder certifies that it is not currently engaged in, and will not for the duration of the contract engage in, a boycott of Israel as defined by Tenn. Code Ann. § 12-4-119. This provision shall not apply to contracts with a total value of less than two hundred fifty thousand dollars (\$250,000) or to contractors with less than ten (10) employees.

According to the law, a boycott of Israel means engaging in refusals to deal, terminating business activities, or other commercial actions that are intended to limit commercial relations with Israel, or companies doing business in or with Israel or authorized by, licensed by, or organized under the laws of the State of Israel to do business, or persons or entities doing business in Israel, when such actions are taken:

- 1) In compliance with, or adherence to, calls for a boycott of Israel, or
- 2) In a manner that discriminates on the basis of nationality, national origin, religion, or other unreasonable basis, and is not based on a valid business reason. Tenn. Code Ann. § 12-4-119.

<b>Signature of Authorized Representative</b>	<b>Date</b>
<b>Printed Name</b>	<b>Phone Number / Email Address</b>

AGREEMENT

THIS AGREEMENT made and entered into this the \_\_\_\_\_ day of \_\_\_\_\_,  
20\_\_\_\_, by and between \_\_\_\_\_  
doing business as \_\_\_\_\_  
(an individual) or (a partnership) or (a corporation)

hereinafter called the Contractor, and the City of Dayton, Tennessee, hereinafter called  
the Owner:

WITNESSETH:

That the Contractor, for the consideration hereinafter fully set out, hereby agrees  
with the Owner as follows:

1. Scope of the Work

That the Contractor shall furnish all labor, materials, tools, machinery and service,  
to complete the construction of Water System Improvements, Contract 23-01 –  
Summer City Road Water Relocation, for the Owner, in the manner and form as  
provided by the Detailed Specifications and Documents attached hereto and  
enumerated as follows:

a. Plans

City of Dayton, Tennessee – Contract 23-01 – Summer City Road Water  
Relocation, Sheets 1 through 6.

AGREEMENT  
4657 – March 2024

b. Specifications and Contract Documents

	<u>Pages</u>
(1) Advertisement for Bids	AB 1 – 3
(2) Instructions to Bidders	IB 1 – 10
(3) General Conditions	GC 1 – 72
(4) Supplementary Conditions	SC 1 – 2
(5) SLRF Supplemental Conditions	
(6) A Listing of the Duties, Responsibilities and Limitations of Authority of the Resident Project Representative	Pages 1 – 4
(7) BID FORM	BF, 1 – 11
(8) Bid Bond	BB, 1 – 3
(9) Acknowledgement Regarding SAM Registration	
(10) Certification of Bidder Regarding Equal Employment Opportunity	
(11) Certification of Bidder Regarding Use of Women/ Minority Subcontractors	
(12) Certification Regarding Debarment, Suspension and Other Responsibility Matters	
(13) Certification by Proposed Subcontractor Regarding Equal Employment Opportunity	
(14) Certification of Subcontractor Regarding Debarment, Suspension, Ineligibility and Exclusion	
(15) Byrd Anti-Lobbying Amendment Certification	
(16) Drug-Free Workplace Affidavit	
(17) Statement of Compliance Certificate Illegal Immigrants	
(18) Iran Divestment Act Certification	
(19) Non-Boycott of Israel Certification	
(20) Agreement	A, 1 – 7
(21) Performance Bond	PEB, 1 – 2
(22) Payment Bond	PAB, 1 – 2
(23) Detailed Specifications	
Section 1 – General Scope and Special Provisions	DS 1, 1 – 14
Section 2 – Testing and Control of Materials	DS 2, 1 – 5
Section 3 – Concrete and Reinforcing Steel	DS 3, 1 – 26
Section 4 – Water Lines and Appurtenances	DS 4, 1 – 23
Section 5 – Basis of Payment	DS 5, 1 – 4
(24) Addenda _____, _____, _____, _____, _____	

all identified as Water System Improvements for the City of Dayton, Tennessee, Contract 23-01 – Summer City Road Water Relocation,

AGREEMENT  
4657 – March 2024

Project Number 4657, March 2024, as prepared by the Engineer, J. R. Wauford & Company Consulting Engineers, Inc., Nashville, Tennessee, and shall do everything required by this Agreement, Advertisement for Bids, Instructions to Bidders, General Conditions, Detailed Specifications, BID FORM, Payment Bond, Performance Bond, and Addenda.

2. Time for Commencement and Completion

That the Contractor shall commence the work to be performed under this Agreement on written order of the Engineer and shall fully complete all work hereunder within the following number of consecutive calendar days from and including said date.

Contract 23-01 – Within sixty (60) consecutive calendar days

3. Payments

The Owner hereby agrees to pay to the Contractor for the faithful performance of this Agreement, subject to additions and deductions as provided in the Detailed Specifications and Contract Documents, in lawful money of the United States, as follows:

the full sum of \_\_\_\_\_ Dollars  
\_\_\_\_\_ Cents (\$\_\_\_\_\_).

4. Progress Payments

The Owner shall, in a timely manner, make partial payments to the Contractor on the basis of a Partial Payment Request approved by the Engineer for work performed during the preceding calendar month by the Contractor, less five (5) percent, as required by Tennessee law, of the amount of such Partial Payment Request which is to be retained by the Owner until all work has been performed strictly in accordance with this Agreement and until such work has been accepted by the Owner.

5. Final Payment

After the completion by the Contractor of all work covered by this Agreement, and the acceptance of such work by the Owner and upon submission by the Contractor of an affidavit satisfactory to the Owner that all payrolls, material bills, and other costs incurred by the Contractor in connection with the construction of the work have been paid in full, final payment on account of this Agreement shall be made within sixty (60) days.

6. Liquidated Damages

It is mutually agreed between the parties hereto that time is the essence on each and every portion of this Contract. If the said Contractor shall neglect, fail or refuse to complete the work within the time specified within the Contract, or within any proper extension thereof granted by the Owner, then the Contractor does hereby agree to pay, either by means of deduction from the compensation due

AGREEMENT  
4657 – March 2024

the Contractor under this Contract or by direct payment by the Contractor to the Owner, not as a penalty, but as liquidated damages, the sum of one thousand (\$1,000.00) dollars, per calendar day as a result of said neglect, failure, or refusal to complete and the attendant delay thereto, including any and all additional engineering and resident observation cost, reasonable attorney's fees, all revenue lost, and all other associated expenses per calendar day, Sunday and holidays included, for each day thereafter that the work remains uncompleted.

7. Additional Bond

It is further mutually agreed between the parties hereto that if, at any time after the execution of this Agreement and the Performance Bond and the Payment Bond hereto attached for its faithful performance, the Owner shall, for cause, deem the surety or sureties upon such bond to be unsatisfactory, or if for any reason such bonds ceases to be adequate to cover the performance of the work, the Contractor shall, at his expense, within ten days after the receipt of notice from the Owner so to do, furnish an additional bond or bonds in such form and amount, and with such surety or sureties as shall be satisfactory to the Owner. In such event, no further payment to the Contractor shall be deemed to be due under this Agreement until such new or additional security for the faithful performance of the work shall be furnished in manner and form satisfactory to the Owner.



8. Hold Harmless Clause

The Contractor agrees to indemnify and hold harmless the Owner, their officers, agents and employees from any and all liabilities for personal injury of damages and claims of every kind arising out of or in any way related to the Contractor's negligent performance.

IN WITNESS WHEREOF the parties hereto have executed this Agreement on the day and date first above written in 6 counterparts, each of which shall, without proof or accounting for the other counterparts, be deemed an original contract.

AGREEMENT  
4657 – March 2024

CONTRACTOR: \_\_\_\_\_

BY: \_\_\_\_\_

NAME: \_\_\_\_\_

(PLEASE TYPE)

TITLE: \_\_\_\_\_

(SEAL)

ATTEST OR WITNESS:

\_\_\_\_\_

NAME: \_\_\_\_\_

(PLEASE TYPE)

OWNER: CITY OF DAYTON, TENNESSEE

BY: \_\_\_\_\_

NAME: \_\_\_\_\_

(PLEASE TYPE)

TITLE: \_\_\_\_\_

(SEAL)

ATTEST:

\_\_\_\_\_

NAME: \_\_\_\_\_

\*\*\*\*\*

PERFORMANCE BOND

KNOW ALL MEN BY THESE PRESENTS: that

\_\_\_\_\_  
(Name of Contractor)

\_\_\_\_\_  
(Address of Contractor)

a \_\_\_\_\_ hereinafter called  
(Corporation, Partnership or Individual)

Principal, and \_\_\_\_\_  
(Name of Surety)

\_\_\_\_\_  
(Address of Surety)

hereinafter called "Surety", are held and firmly bound unto

\_\_\_\_\_  
City of Dayton, Tennessee  
(Name of Owner)

\_\_\_\_\_  
399 First Avenue, Dayton, Tennessee 37321  
(Address of Owner)

hereinafter called "Owner", in the penal sum of \_\_\_\_\_  
Dollars \_\_\_\_\_ Cents (\$ \_\_\_\_\_) in lawful money of the United States, for the  
payment of which sum well and truly to be made, we bind ourselves, successors, and  
assigns, jointly and severally, firmly by these presents.

THE CONDITION OF THIS OBLIGATION is such that whereas, the Principal  
entered into a certain contract with the Owner dated \_\_\_\_\_ day of \_\_\_\_\_,  
20\_\_, a copy of which is hereto attached and made a part hereof for the construction of:

Water System Improvements  
Contract 23-01 – Summer City Road Water Relocation  
Wauford Project No. 4657

NOW, THEREFORE, if the Principal shall well, truly and faithfully performs its  
duties, all the undertakings, covenants, terms, conditions, and agreements of said  
contract during the original term thereof, and any extensions thereof which may be  
granted by the Owner, with or without notice to the Surety, and if he shall satisfy all  
claims and demands incurred under such contract, and shall fully indemnify and save  
harmless the Owner from all cost and damages which it may suffer by reason of failure  
to do, and shall reimburse and repay the Owner all outlay and expense which the Owner  
may incur in making good any default, then this obligation shall be void; otherwise to  
remain in full force and effect.

PERFORMANCE BOND  
4657 – March 2024

PROVIDED, FURTHER, that the said surety, for value received hereby stipulates and agrees that no change, extension of time, alteration or addition to the terms of the contract or to the work to be performed thereunder or the specifications accompanying the same shall in any wise affect its obligation on this bond, and it does hereby waive notice of any such change, extension of time, alteration or addition to the terms of the contract or to the work or to the specifications.

PROVIDED, FURTHER, that no final settlement between the Owner and the Contractor shall abridge the right of any beneficiary hereunder, whose claim may be unsatisfied.

IN WITNESS WHEREOF, this instrument is executed in 6 counterparts, each one of which shall be deemed an original, this the \_\_\_\_\_ day of \_\_\_\_\_, 20\_\_.

WITNESSES:

\_\_\_\_\_  
Principal

\_\_\_\_\_

BY: \_\_\_\_\_

\_\_\_\_\_

\_\_\_\_\_  
Address

(SEAL)

WITNESSES:

\_\_\_\_\_  
Surety

\_\_\_\_\_

BY: \_\_\_\_\_

\_\_\_\_\_

Attorney-in-Fact

NOTE: Surety companies executing bonds must appear on the Treasury Department's most current list (Circular 570 as amended) and be authorized to transact business in the state where the project is located.

\*\*\*\*\*

PAYMENT BOND

KNOW ALL MEN BY THESE PRESENTS: that

\_\_\_\_\_  
(Name of Contractor)

\_\_\_\_\_  
(Address of Contractor)

a \_\_\_\_\_ hereinafter called  
(Corporation, Partnership or Individual)

Principal, and \_\_\_\_\_  
(Name of Surety)

\_\_\_\_\_  
(Address of Surety)

hereinafter called "Surety", are held and firmly bound unto

\_\_\_\_\_  
City of Dayton, Tennessee  
(Name of Owner)

\_\_\_\_\_  
399 First Avenue, Dayton, Tennessee 37321  
(Address of Owner)

hereinafter called "Owner", in the penal sum of \_\_\_\_\_  
Dollars \_\_\_\_\_ Cents (\$\_\_\_\_\_) in lawful money of the United States, for the  
payment of which sum well and truly to be made, we bind ourselves, successors, and  
assigns, jointly and severally, firmly by these presents.

THE CONDITION OF THIS OBLIGATION is such that whereas, the Principal  
entered into a certain contract with the Owner dated \_\_\_\_\_ day of \_\_\_\_\_,  
20\_\_\_, a copy of which is hereto attached and made a part hereof for the construction of:

Water System Improvements  
Contract 23-01 – Summer City Road Water Relocation  
Wauford Project No. 4657

NOW, THEREFORE, if the Principal shall promptly make payment to all persons,  
firms, subcontractors, and corporations furnishing materials for or performing labor in  
the prosecution of the work provided for in such contract, and any authorized extension  
or modification thereof, including all amounts due for materials, lubricants, oil, gasoline,  
coal and coke, repairs on machinery, equipment and tools consumed or used in  
connection with the construction of such work, and all insurance premiums on said work,  
and for all labor, performed in such work whether by subcontractor or otherwise, then  
this obligation shall be void; otherwise to remain in full force and effect.

PAYMENT BOND  
4657 – March 2024

PROVIDED, FURTHER, that the said surety, for value received hereby stipulates and agrees that no change, extension of time, alteration or addition to the terms of the contract or to the work to be performed thereunder or the specifications accompanying the same shall in any wise affect its obligation on this bond, and it does hereby waive notice of any such change, extension of time, alteration or addition to the terms of the contract or to the work or to the specifications.

PROVIDED, FURTHER, that no final settlement between the Owner and the Contractor shall abridge the right of any beneficiary hereunder, whose claim may be unsatisfied.

IN WITNESS WHEREOF, this instrument is executed in 6 counterparts, each one of which shall be deemed an original, this the \_\_\_\_\_ day of \_\_\_\_\_, 20\_\_.

WITNESSES:

\_\_\_\_\_  
Principal

\_\_\_\_\_

BY: \_\_\_\_\_

\_\_\_\_\_

\_\_\_\_\_  
Address

(SEAL)

WITNESSES:

\_\_\_\_\_  
Surety

\_\_\_\_\_

BY: \_\_\_\_\_

Attorney-in-Fact

\_\_\_\_\_

NOTE: Surety companies executing bonds must appear on the Treasury Department's most current list (Circular 570 as amended) and be authorized to transact business in the state where the project is located.

\*\*\*\*\*

SECTION 1

GENERAL SCOPE AND SPECIAL PROVISIONS

1. Scope

The work to be accomplished under these Detailed Specifications consists of furnishing all labor, materials, equipment and services necessary for the construction of Water System Improvements, Contract 23-01 – Summer City Road Water Relocation for the for the City of Dayton, Tennessee. The work involved is in one (1) contract and consists of the following generally described work:

CONTRACT 23-01  
SUMMER CITY ROAD WATER RELOCATION

- Relocation of approximately 382 L.F. of 6-inch Water Line
- Relocation of approximately 1,725 L.F. of 4-inch Water Line
- Relocation of approximately 43 L.F. of 2-inch Water Line
- Open-cut Highway Crossings, Creek Crossing and Service Reconnections

and all other appurtenances shown on the Plans.

2. Execution and Coordination of the Work

It is intended that the work covered by this Contract be done so as to cause the minimum interference with the normal operation of the existing facilities of the Owner.

The Contractor shall be required to organize and schedule his work so as to keep the existing facilities in full operation during the construction period insofar as is consistent with the nature of the construction work to be performed.

The manner in which shutdowns will be made and the Contractor's work schedule are subject to the approval of the Owner and the Engineer. Although every effort will be made to cause the minimum amount of interference with the Contractor's work, the interest of the Owner in regard to the existing facilities must always take precedence over the construction work.

THEREFORE, THE RIGHT IS RESERVED BY THE OWNER TO PUT ANY LINES OR OTHER FACILITIES THAT MAY BE SHUT DOWN FOR THE CONSTRUCTION WORK BACK INTO SERVICE WHEN AN EMERGENCY ARISES.

The Contractor must have sufficient materials, equipment, labor, and supervision available to accomplish the work required in the time allocated for any shutdown of the existing sanitary sewer system.

3. Temporary Traffic Control Plan

When work is conducted within the right-of-way of transportation agencies or city or county roadways, the Contractor shall provide temporary traffic control (TTC) in accordance with the Manual on Uniform Traffic Control Devices (MUTCD). TTC devices shall include but shall not be limited to signs, barricades, flagmen and channelization devices. The Contractor shall provide TTC for all roadway users including motorists, bicyclists and pedestrians. All TTC shall be in accordance with the Americans with Disabilities Act of 1990, Title II, Paragraph 35.130.

4. Time of Completion and Liquidated Damages (see **Article 4** of the General Conditions)

Time is of the essence on this contract and work on this contract shall be prosecuted in a timely manner.

Time of completion after notice to proceed will be as follows:

Sixty (60) consecutive calendar days

If the work is not completed within the time specified, liquidated damages in the amount of \$1,000 per calendar day will be deducted from the compensation otherwise due to the Contractor(s) in accordance with the Contract Documents for each calendar day thereafter, Sundays and holidays included, that the work remains uncompleted.

The Contractor's attention is called to **Article 4** of the General Conditions regarding contract completion date time extensions.

5. Guarantee – One Year Warranty

The Contractor shall guarantee all work performed under these contracts for a period of one year after the date of Substantial Completion in accordance with the requirements of **Paragraph 15.08** of the General Conditions. The Engineer will perform an inspection of the project one year after its acceptance accompanied by the Contractor.

6. Engineer's Authority

See **Paragraph 10.04** of the General Conditions.



7. Shop Drawings (See **Paragraph 7.16** of the General Conditions)

The Contractor(s) shall submit shop drawings for all preconstruction submittals, materials, equipment, and services used on this project.

For submittals containing less than 25 pages, the Contractor shall email one (1) digital copy of the submittal to [ntoshopdrawings@jrwauford.com](mailto:ntoshopdrawings@jrwauford.com). For submittals containing 25 pages or more, the Contractor shall submit one (1) digital copy and three (3) hard copies to the Engineer for review. Note that all sheets shall be printed at 100% of original size.

THE ENGINEER WILL HOLD ALL SUBMITTED OR REVIEWED SHOP DRAWINGS UNTIL THE CONTRACTOR HAS PROVIDED ACCEPTABLE SUBMITTALS FOR THE CONTRACTOR'S PLANNED ORDER OF WORK, PROGRESS SCHEDULE, PRE-CONSTRUCTION VIDEOS/PICTURES AND SHOP DRAWING LOG. IF REQUESTED BY THE CONTRACTOR, AN ACCEPTABLE TEMPLATE OF THE SHOP DRAWING LOG WILL BE PROVIDED BY THE ENGINEER.

REJECTION OF THE SAME SHOP DRAWING ON THREE (3) SEPARATE OCCASIONS WILL CONSTITUTE GROUNDS FOR TOTAL REJECTION OF THE PROPOSED EQUIPMENT MANUFACTURER OR SUPPLIER AS BEING UNABLE OR UNWILLING TO MEET THESE DETAILED SPECIFICATIONS.

Shop drawings submittals shall include a transmittal letter listing the submittal description, project name, project contract number, and project location. Shop drawings shall be checked by the Contractor(s) and evidence of such checking shall be indicated on the transmittal letter. The Contractor(s) shall be completely responsible for accuracy, completeness, compliance with Plans and Detailed Specifications, and compatibility, the Engineer's approval notwithstanding. WORK SHALL BE PERFORMED ONLY BY USE OF APPROVED SHOP DRAWINGS. THE CONTRACTOR(S) SHALL PLAINLY MARK ON HIS SUBMITTAL THE ITEM OR ITEMS IN WHICH HE IS REQUESTING APPROVAL. FAILURE TO DO SO WILL GIVE THE ENGINEER THE RIGHT TO EITHER REJECT THE SUBMITTAL OR SELECT THE ITEM OF HIS CHOICE AT NO ADDITIONAL COST TO THE OWNER.

THE ENGINEER RESERVES THE RIGHT TO TAKE UP TO TWENTY (20) WORKING DAYS FOR ACTION ON ANY GIVEN SHOP DRAWING. THE CONTRACTOR(S) SHALL BE SOLELY RESPONSIBLE FOR TIMELY SUBMISSION OF SHOP DRAWINGS BASED ON THE ABOVE AND NO EXTRA FOR TIME OR COSTS WILL BE ACCEPTABLE.

After approval, the Engineer will make the following distribution: one (1) set to the Owner, one (1) set to Engineer's central files, one (1) set to the Engineer's Resident Project Representative, and one (1) digital set to the Contractor. The

Contractor shall keep one (1) hard copy of the approved shop drawing at the project site and shall be responsible for providing the document to suppliers and/or manufacturers.

8. Initial Videos, Pictures and Progress Pictures

Before beginning the job, the Contractor shall make videos and pictures showing the status before any construction has begun. The videos and pictures shall be made, submitted and approved prior to the beginning of work. The Contractor shall submit the videos and pictures in an electronic format suitable to the Engineer.

The Contractor shall furnish digital progress pictures to the Engineer at the end of each month at the time the partial pay estimate is submitted. Pictures shall be of highest quality clearly showing the work and preferably not showing workmen or passersby. The name of the project, the item or scene pictured, Contractor's name, and the date shall be incorporated into the file name for each picture. Five (5) pictures shall be required with each partial pay estimate. Each electronic file should be date and time stamped. REQUESTS BY THE CONTRACTOR FOR PARTIAL PAYMENTS WILL NOT BE CONSIDERED WITHOUT THE REQUIRED PROGRESS PICTURES.

After construction and clean-up are completed, the Contractor shall submit video and pictures showing the cleaned up work and all of the progress pictures for the project in an electronic format suitable to the Engineer.

9. Progress Schedule and Progress Meetings

The Contractor shall furnish five (5) copies of a suitable progress chart or schedule in graphical form showing the estimated schedule for the project as required in **Paragraphs 2.03 and 4.04** of the General Conditions. After approval, the Contractor shall update the chart monthly showing the actual progress on the project for each specific item of work in relation to the estimated schedule.

FAILURE TO SUBMIT SAID PROGRESS SCHEDULE AND KEEP IT CURRENT MONTHLY SHALL BE GROUNDS FOR NONPAYMENT OF PARTIAL PAYMENT REQUESTS.

The Engineer and Owner may elect to conduct monthly progress meetings on-site with the Contractor, the Owner and the Engineer to discuss progress, any problems encountered and other appropriate subjects.

10. Utilities Required by Contractor

All electric current and/or utility service required by the Contractor shall be furnished at his own expense.

11. Project Sign

A project sign is required as depicted at the end of Section 1.

12. Field Office

A field office is not required; however, the Contractor shall have a responsible representative on site who can officially receive instructions from the Engineer.

13. Existing Utilities

Special precautions shall be taken by the Contractor to avoid damage to existing overhead and underground utilities owned and operated by the Owner or by public or private utility companies.

The Contractor shall contact Tennessee "One Call" at 1-800-351-1111 or 811 at least 72 business hours in advance of digging. Before proceeding with the work, the Contractor shall confer with all public or private utilities in the vicinity of the construction work. The purpose of the conference or conferences shall be to notify said companies, agencies or departments of the proposed construction schedule, verify the location of and possible interference with the existing utilities, arrange for necessary suspension of service where possible and approved by the Utility, and make arrangements to locate and avoid interference with all utilities. The Engineer and Owner have no objection to the Contractor arranging for said Utility Companies, Agencies or Departments to locate and uncover their own utilities; however, the Contractor shall bear the entire responsibility for locating and avoiding or repairing damage to said existing utilities. **WORK SHALL NOT PROCEED WITHOUT ALL UNDERGROUND UTILITIES BEING LOCATED AND MARKED.**

The Contractor shall locate all unknown metallic hazards, namely buried pipe, metals, *etc.*, by using a pipe locator, or whatever better methods the Contractor may elect to use. All hazards should be located and marked with a stake in such manner as to notify the equipment operator of such hazard.

Where existing utilities or other underground structures are encountered, they shall not be displaced or molested unless necessary and approved by the Owner, and in such case they shall be replaced in as good or better condition than found as quickly as possible. All such utilities that are so damaged or molested shall be replaced at the Contractor's expense, unless in the opinion of the Engineer such damage was caused through no fault of the Contractor.

It is expected that the Contractor will be diligent in his efforts and use every possible means to locate existing utilities. Any claims for unavoidable damage, based on improper or unknown locations, will be thoroughly examined in light of

the Contractor's efforts to locate the said utilities or obstructions prior to beginning construction.

14. Permits, Codes, Agreements and/or Contracts with Private Utilities

The Contractor shall make application for, obtain, and pay for all licenses, permits, agreements, and/or contracts with private utility companies and shall pay all fees and charges in connection therewith.

15. Protection of Roadways On and Off-Site

In the hauling of materials and/or equipment to and from the site of the work, the Contractor shall take care to protect county roads, highways, parking areas and/or city streets. The Contractor shall be responsible for repair of highways, roads, parking areas or streets damaged by his operations (or operations of his subcontractors) and shall repair said damage to the original condition. If repair to the original condition is not practical or possible, the Contractor shall be responsible for obtaining proper release from the owner of the damaged roadway.

16. Lands, Rights-of-Way and Limits of Work (see **Article 5** of the General Conditions)

a. Lands and Easements

In general, the work will be constructed on easements held by the Owner or on street rights-of-way owned by the Tennessee Department of Transportation or the Bledsoe County Highway Department.

The Contractor shall be responsible for obtaining necessary work permits from the City of Dayton and/or the Bledsoe County Highway Department.

b. Limits of Work

The Contractor shall limit his work area and storage to the Owner's property and/or permanent utility easements shown on the Plans. The Contractor shall not encroach or dump excess or waste materials on property adjacent to the work sites unless written permission is first received from the affected property owner and a copy submitted to the Engineer. Where excess materials are to be dumped off-site, the Contractor shall furnish the Owner written evidence of the property owner's permission.

In connection with work performed on easements or adjacent to private property, the Contractor shall take all reasonable care to avoid damage to the property owners' buildings, grounds and facilities and shall be completely responsible for the repair of damage to same. It is intended

that when construction is complete, the easements and the private property owners' facilities and grounds shall be restored to as good or better than original condition as possible.

Large trees or other facilities within the actual construction limits that cannot be preserved and replaced shall be removed by the Contractor. THE OWNER WILL ASSUME THE RESPONSIBILITY FOR SETTLING WITH THE PROPERTY OWNER FOR THE LOSS OF SAID TREES OR FACILITIES WITHIN THE CONSTRUCTION AREA. THE CONTRACTOR IS RESPONSIBLE FOR ALL OTHER DAMAGES.

Reasonable care shall be taken during construction to avoid damage to vegetation. Ornamental shrubbery and tree branches shall be temporarily tied back, where appropriate, to minimize damage. Trees which receive damage to branches shall be trimmed of those branches to improve the appearance of the tree. Tree trunks receiving damage from equipment shall be treated with a tree dressing.

17. Undesirable Workmen

The Engineer reserves the right, but in so doing does not assume responsibility to make a judgment (the primary responsibility rests upon the Contractor), to remove inept or uncooperative servicemen as "Undesirable Workmen".

18. Work Hours

No night, weekend or Holiday work requiring the presence of the Engineer or Owner representatives will be permitted, except in case of emergency, and then only to the extent such work is necessary for protection of the work, and only with written approval of the Engineer. This clause shall not apply on such work which can only be performed at night.

19. Materials or Equipment to be Furnished (see **Paragraphs 7.04** and **7.05** of the General Conditions)

Where the specifications state "equal to" followed by a brand name or model, a standard of quality is being set. The naming of a brand or model is a matter of convenience to avoid writing a volume. Other brands or equipment under this category may be submitted at the shop drawing stage of construction. The Engineer will consider other products on the basis of materials of construction, weight, function, size (it must fit the space provided), service history and electrical and mechanical characteristics.

Where the specifications state one or more model numbers and manufacturers followed by the words "or approved equal" the meaning is that the product(s) specified is acceptable and that while there may be other products that are

acceptable the only way to be assured is to submit the desired substitution during the BID PROCESS and receive an affirmative answer in the form of a letter or an addendum. The Engineer will consider the factors previously described in making the determination.

Unless otherwise specified, all materials shall be the best of their respective kinds and shall be in all cases fully equal to approved samples. The Engineer shall have the right to require the use of such specifically designated material, article, or process. The Engineer, where practical, may require submission of actual samples of materials or products.

20. Occupational Safety and Health Act

The Contractor's attention is called to **Paragraph 7.13** of the General Conditions.

21. Noise, Odor and Dust Control

The work hereunder may be performed within a residential area of the City of Dayton. The Contractor shall be responsible for noise, odor and dust abatement procedures and shall not commence work in these areas before 7:00 a.m. local prevailing time.

22. Chemical Requirements

All chemicals used during project construction or furnished for project operation, whether herbicide, pesticide, disinfectant, polymer, reactant or of other classifications, must show approval of either EPA or USDA. Use of all such chemicals and disposal of residues shall be in strict conformance with the Material Safety Data Sheets.

23. Confined Spaces

During the construction of the facilities to be built under the terms of this contract, it may be necessary for the OWNER'S or the ENGINEER'S representative(s) to enter "confined space(s)", as defined by OSHA Regulations, in order to observe the work of the Contractor and/or in order to determine compliance with the terms of the contract. The Contractor shall provide the proper "Permit", the "Attendant", and/or the "Entry-Supervisor", the testing safety and emergency equipment and all other means of compliance with OSHA regulations. The OWNER or the ENGINEER will provide general training to their respective proposed "authorized Entrant(s)" who are employees of the OWNER or the ENGINEER, however the Contractor shall provide any specialized training required for the equipment furnished, the Contractor's Permit System or any other condition special to the work to be performed. The Contractor shall submit a copy of its written Permit System prior to the commencement of construction and shall be fully responsible for compliance with the appropriate regulations.

24. Lines and Grades

The Engineer has established survey baselines for the work. Benchmarks were set at the time of the original survey, the locations and elevations of which are shown on the Plans. These benchmark elevations were checked and verified at the time of the original survey.

Where tie-ons to existing lines or structures are to be made, the actual inverts of the existing lines or elevations of existing structures shall be field checked for verification before construction begins.

Any apparent discrepancy or error discovered in these benchmark elevations shall be reported to the Engineer immediately at telephone number 615-883-3243. Written approval from the Engineer shall be obtained before any changes are made.

25. Restoration of Disturbed Areas in Connection with Work on or Adjacent to Private Property

In connection with work performed on or adjacent to private property, the Contractor(s) shall take all reasonable care to avoid damage to the property Owners' buildings, grounds and facilities and shall be completely responsible for the repair of damage to same. Fences, hedges, shrubs, *etc.*, within the construction limits shall be carefully removed, preserved, and replaced when the construction is completed. Where ditches or excavations cross lawns, the sod shall be removed carefully and replaced when the backfilling has been completed. If sod is damaged or not handled properly, it shall be replaced with new sod equal to existing sod at the Contractor's expense. All unpaved areas, other than lawns, shall be graded, fertilized, and seeded when construction is completed in accordance with the requirements set out in Section 4 of these Detailed Specifications. It is intended that when construction is completed, the private property Owner's facilities and grounds shall be restored to as near their original condition as possible.

Foundations adjacent to an excavation which is to be carried below the bottom of the foundation shall be supported by shoring, bracing, or underpinning, and the Contractor(s) shall be held strictly responsible for any damage to said foundation.

Work on rights-of-way of the State Highway Department or Bledsoe County shall be considered work on Private Property. It shall be the Contractor's responsibility to obtain any necessary work permits.

26. Reference to Tennessee Department of Transportation Specifications and Standard Roadway and Structure Drawings

Where items are referred as being in conformance with Tennessee Department of Transportation Specifications and/or Standard Drawings, certain materials, equipment and construction methods required under this Section of the Detailed Specifications for Road and Bridge Construction and subsequent special provisions and revisions issued by the Tennessee Department of Transportation; and the Standard Roadway and Structure Drawings (current revision) adopted by the Tennessee Department of Transportation (TDOT), Bureau of Highways, on January 1, 2021 as amended and/or modified herein.

27. References to Standard General Conditions of the Construction Contract

Where references are provided within this Project Manual to the Standard General Conditions of the Construction Contract, they are provided for the benefit of the Contractor. Where conditions may be repeated or expanded in this Section, they shall be in addition to those requirements stated in the Standard General Conditions of the Construction Contract. Where any conflicts may exist with the Standard General Conditions of the Construction Contract and text found elsewhere in the Project Manual, the Standard General Conditions of the Construction Contract shall prevail.

28. Applicability of Governing Standards

The latest version of any standard listed in these Detailed Specifications as of the bid date shall apply. In cases that an incorrect revision year is listed, it shall not apply - the latest version as of the bid date shall apply.

29. Connecting to Existing Lines and Facilities

The Contractor shall make the required connections to existing lines and structures as shown on the Plans and as specified in these Detailed Specifications. Refer to Paragraph 2. Execution and Coordination of the Work and Paragraph 24. Lines and Grades of this Section of these Detailed Specifications.

The work of connecting new lines to existing lines and new structures to existing structures is the responsibility of the Contractor and is NOT a separate pay item unless indicated otherwise in the BID FORM; it being the intent of these Detailed Specifications to provide a complete operable facility.



30. Subsurface Conditions/Site Conditions

As provided by **Paragraph 5.03** and **5.04** of the General Conditions, subsurface conditions are unknown unless a Geotechnical Report is included at the end of Section 1.

31. Blasting

Blasting will not be allowed on this project.

32. Water and Uplift

The Contractor(s) shall, by the use of well points, pumps or other approved methods, prevent the accumulation of water in excavated areas. Should water accumulate, it shall be promptly removed. The Contractor(s) shall also provide for dewatering areas adjacent to structures or lines to prevent uplift during construction operations. The Contractor(s) will be held responsible for any damage due to uplift of such structures or lines and to existing structures during construction operations.

33. Flooding

Some of the work is to be conducted in areas subject to flooding. Obstructions to flow which would cause flooding in the event of heavy rainfall shall be avoided by the Contractor(s).

34. Temporary Project Water Pollution Control (Soil Erosion)

Temporary pollution control provisions shall be taken to avoid damage to embankments and cut slopes and to avoid transport of sediment to adjacent property owners and/or streams.

Pollution and erosion control methods shall include but are not limited to the following:

a. Temporary Berms

Temporary berms shall be constructed of compacted soil with or without a shallow ditch at the top of all excavation and embankment slopes to prevent excessive erosion until the slopes are stabilized.

b. Temporary Slope Drains

Temporary slope drains shall be stone gutters, fiber mats, plastic sheets, concrete or asphalt gutters, half-round pipe, metal pipe, plastic pipe, sod or other material acceptable to the Engineer that may be used to carry water down slopes to reduce erosion.

c. Temporary Silt Fences

Temporary silt fences with baled hay or straw shall be placed on the natural ground, at the bottom of fill slopes, in ditches or other areas where siltation is a problem or where shown on the Plans.

Silt fences are constructed of wire mesh fence with a covering of filter cloth composed of burlap, plastic filter fabric or some other suitable material on the upper grade side of the fence and anchored into the soil.

Bales shall be either hay or straw containing five (5) cubic feet or more of material.

The above listed pollution and erosion control methods shall be used at the discretion of the Contractor or where directed by the Engineer. Temporary pollution control is NOT a separate pay item.

The Contractor shall be solely and strictly liable for any violations of State or Federal water pollution laws, regulations, or standards caused during construction by the Contractor's forces or subcontractors and shall pay any penalties levied by any party due to said violations.

The Contractor shall maintain all areas where excavation and backfill construction operations are being performed or have been performed in order that siltation, erosion and other forms of stormwater pollution caused by construction activities will be kept to a minimum during construction. The Engineer will prepare the Storm Water Pollution Prevention Plan (SWPPP) and obtain approval thereof from the Tennessee Department of Environment and Conservation if required. The Contractor is responsible for complying with said SWPPP.

35. Substantial Completion/Delays in Final Completion

See **Paragraph 15.03** of the General Conditions.

In order to allow all outstanding incomplete items to be completed during the initial start-up and operating period, a semi-final inspection will be made upon request by the Contractor after the beginning of the initial start-up period. In no event will the date of substantial completion of the Contract for purposes of determining

payment of the liquidated damages be set before the beginning of the initial start-up period.

36. Finish Grading, Topsoiling, Seeding and Sodding

Finish grading of disturbed areas shall be performed in accordance with the finished elevations and grades shown on the Plans and shall be made to blend into conformation with remaining natural ground surfaces. All finished grading surfaces shall be left smooth and free to drain. The tops of all cuts shall have berm ditches. Selected materials, which have been obtained from stripping the site, shall be spread upon the slopes of fills and other areas inside the fence to a uniform depth and compacted suitable for planting. Excess materials shall be spread and compacted as directed. The top four (4) to six (6) inches of material in areas to be grassed shall be topsoil.

Soil tests shall be performed to determine the seed and fertilizer requirements. For the purposes of bidding, the following grass and fertilizer requirements shall be used:

Annual Rye Grass	application rate	28 lb/acre
Kentucky Fescue #31	application rate	28 lb/acre
Inoculated Clover	application rate	7 lb/acre
Ammonium Nitrate	application rate	200 lb/acre
Lime, if required	application rate	200 lb/acre
Commercial Fertilizer	application rate	400 lb/acre
Straw	application rate	3,000 lb/acre

Seed shall be certified to contain no more than 3 percent weeds.

All graded areas shall be topsoiled with materials stripped from the site. If the Contractor fails to stockpile the topsoil, then material shall be brought in. The topsoil shall be left smooth and, after the fertilizer and/or lime has been distributed, it shall be disced or harrowed into the soil.

Sod shall be locally available, reasonably free of weeds and approved by the Engineer, carefully cut, transported and laid. Sod shall be so laid that no voids occur between strips. Weed roots shall be removed as the sod is laid. Sod shall be tamped or rolled immediately after it is laid, and the finished surface shall be true to grade, even and equally firm at all points. Well screened topsoil shall be lightly sprinkled over the sodded areas and shall be raked to ensure sealing the sod joints.

37. Final Inspection

The final inspection will be conducted after the completion of all the work required under this Contract and upon the written request of the Contractor. The date of substantial completion will not be set prior to final inspection.

38. Disposal of Demolition Debris

The Contractor shall be responsible for the disposal of demolition debris created by this project. The Contractor shall furnish the Owner and Engineer with written evidence of the property owner's permission.

\*\*\*\*\*

# STATE WATER INFRASTRUCTURE GRANTS

## IDENTIFICATION SIGN

All plans and specifications for each project approved shall contain provisions for requiring the general contractor to provide identification signs. The signs shall conform to the following basic features:

1. The following diagram shall be used as a design:

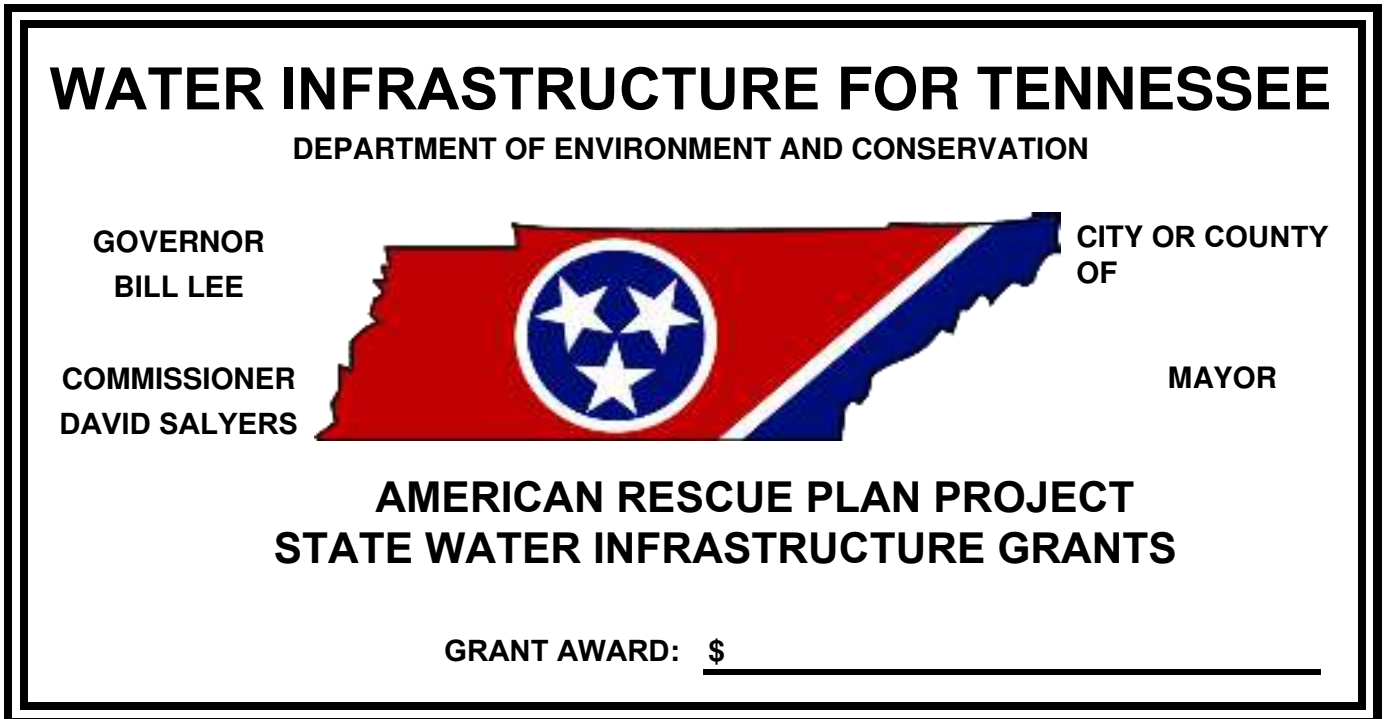

2. The sign shall be a 4'0" X 8'0" sheet of exterior grade plywood and shall be built so as to remain erected during the entire construction phase of the project.
3. The background of both sides shall be white. The lettering shall be black and shall be large enough to take advantage of the full size of the plywood. The stars shall be white set on a blue field and surrounded by a white ring placed inside a state map in red with a stripe of white and blue on the right side. The sign shall be bordered by a one-inch blue stripe.

## SECTION 2

### TESTING AND CONTROL OF MATERIALS

#### 1. Scope

This Section together with such additions, deletions, or modifications, if any, as may appear in any other particular Section of these Detailed Specifications shall govern the furnishing and testing of materials to be used in the work.

Materials of construction, particularly those upon which the strength and durability of the structure or the integrity of a pipeline may depend, shall be subject to inspection and testing to establish conformance with specifications and suitability for uses intended.

#### 2. Cost of Tests and Selection of Testing Agencies

All materials and equipment used in the construction of the project shall be subject to adequate review and testing in accordance with accepted standards. The laboratory or inspection agency will be selected by the Contractor subject to the approval of the Engineer and the Owner. THE CONTRACTOR SHALL PAY FOR ALL DULY AUTHORIZED LABORATORY INSPECTION AND/OR TESTING SERVICE.

#### 3. Sources of Supply

The Contractor shall submit a list indicating their proposed sources of supply of all materials including manufactured items and receive the Engineer's approval prior to the placing of orders. The Engineer may require representative samples of any materials prior to approval of the source. The Engineer's approval of the source of any sample shall not be construed to relieve the Contractor of furnishing materials which fully meet all provisions of these Detailed Specifications.

If it is found that sources which have been approved do not furnish uniformly acceptable products, the approval may be withdrawn. The Contractor and his supplier shall afford the Engineer's representative opportunities for inspecting products and materials at any time during their preparation. The Contractor and/or supplier shall furnish shipment thereof, without charge.

These requirements are not intended to stifle or hinder completion but are intended to assure quality and/or performance.

4. Approval of Testing Agencies and Reports

Whenever in these Detailed Specifications review and testing of materials are required, bureaus, laboratories, and/or agencies selected by the Contractor for such inspection and testing service shall be subject to approval by the Engineer.

Documentary evidence, satisfactory to the Engineer, that the material has passed the required inspection and testing must be furnished prior to the incorporation of such materials in the work, and rejected materials must be promptly removed from the premise.

Six (6) copies of all test reports shall be sent to the Engineer's office for checking and distribution.

Test reports shall contain as a minimum (1) the name and location of the supplier's plant, (2) the name of the person gathering the sample, (3) the date of the sampling, and (4) such other like data as may be required by the Engineer.

5. Governing Specifications

It is the intention of the Engineer in the preparation of these General and Detailed Specifications to define properly the kind and quality of materials to be furnished. The standards and tentative standards of the American Society of Testing Materials (ASTM); standards of the American Waterworks Association (AWWA); standards of the American National Standards Institute (ANSI); standards promulgated by the Federal Specification Board (Fed. Spec.); American Association of State Highway and Transportation Officials (AASHTO); the Federal Aviation Agency (FAA); or other such agencies may be referred to in the Detailed Specifications. Where such standards are referred to, said references shall be construed to mean the latest amended and/or revised versions of the said standard or tentative specifications. In the selection of samples and the routine testing of materials, the testing laboratory shall follow the standard procedure as outlined by the ASTM, unless otherwise set out.

6. Extent of Inspection and Testing Service

It is intended that materials of construction, particularly those upon which the strength and durability of structures may depend, shall be inspected and tested to establish conformance with specifications and suitability for uses intended. The following is a schedule showing the extent of testing and requirements and methods of reporting. If it is found that this list does not cover all items that will require testing, then such materials shall be tested as directed by the Engineer.

7. Cement

Cement shall have been shipped from the mill not more than three (3) months prior to receipt on the work. Testing and certification of ASTM C 150 shall apply and shall be supplied by the manufacturer.

8. Fine Aggregate (For Use in Cement Concrete)

Fine aggregate shall consist of natural river sand except that upon request the Engineer may approve manufactured sand. SAND MINED FROM HIGHLAND DEPOSITS WILL NOT BE APPROVED.

Standard tests shall be made in advance of concreting by an approved independent laboratory per ASTM C 33 and ASTM C 40 on each fine aggregate proposed to be used. Other tests being satisfactory, the aggregate may be used pending results of 28-day strength tests.

9. Coarse Aggregate (For Use in Cement Concrete)

Standard tests shall be made in advance of concreting by an approved laboratory on each grading of each coarse aggregate proposed to be used per ASTM C 33.

10. Advance Tests of Concrete Design Mix(es)

Before commencement of concrete placing and after approval of cement and aggregates, an independent laboratory shall make from a single batch for each proposed mix a set of six (6) standard four (4) inch cylinders per ASTM C 31 and test in accordance therewith: Test two (2) cylinders at seven (7) days, two (2) cylinders at fourteen (14) days, and two (2) cylinders at twenty-eight (28) days per ASTM C 39. Two (2) beam flexure tests as per ASTM C 78 shall likewise be made and tested from the design batch if the total requirement exceeds 1,000 cubic yards.

The requirements for tests may be modified at the Engineer's discretion without prejudice to the Engineer later requiring same (if he becomes in doubt about the quality of the concrete) if less than fifty (50) cubic yards are required.

11. Reinforcing Steel

A certificate of origin and affidavit will be required for all reinforcing steel. All reinforcing steel shall be manufactured in the United States unless specifically approved by the Engineer. Reinforcing steel shall be inspected for section, rust, shape and dimension. The manufacturer shall supply test reports depicting inspection results plus heat numbers.



12. Structural Steel

Structural steel shall be evaluated at the mill and shop for each heat number to determine compliance with specification designated in these Detailed Specifications.

13. Steel Bar Joists

The manufacturer shall supply test data proving the efficiency of the design of the proposed joists for the purpose intended and certifies that the joists, as furnished, are in accordance with project requirements and with the Standard Specifications for Steel Joists as given in the current handbook "Steel Joist Construction" published by the Steel Joist Institute or other specifications designated in these Detailed Specifications.

14. Brick

Visual examination for shape, color, soundness, cracks, and other imperfections.

15. Building Stone

Visual examination for shape and color.

16. Concrete Pipe

Visual examination at the site, as practicable, per ASTM or other designated specification together with certified test reports from the supplier.

17. Polyvinyl Chloride (PVC) Pressure Pipe

Examination at the site, as practicable, per AWWA, ASTM or other designated specification plus certified test reports from the supplier as performed by the manufacturer.

The following test results shall be supplied by the manufacturer:

Long-Term Pressure Test (Min.)	1,000 hours at 400 psi
Burst Pressure Short Term (Min.)	630 psi
Impact (Min.)	60 ft/lbs at 72°F. 16 ft/lbs at 0°F.
Acetone	20 minutes no flaking
Crush (Ring Section)	100% crush no cracking
Vacuum Test (Min.)	22 in/HG for 1 hr.

18. Polyvinyl Chloride (PVC) Sewer Pipe

Examination at the site, as practicable, per ASTM or other designated specification plus certified test reports from the supplier. Testing shall be in accordance with the requirements of ASTM D 2412. Minimum "pipe stiffness" (F/Y) at five (5) percent deflection shall be forty-six (46) psi or greater for all pipe sizes. The result of all tests shall be reported to the Engineer.

19. Ductile Iron Pipe and Special Castings

Each piece of pipe shall bear the manufacturer's name or trademark and the date cast. Each piece of pipe should also be certified by the manufacturer to have met the requirements of the governing ASTM or other designated specification. Also, each piece shall be visually inspected in the field for specification conformance.

20. Grey Iron Castings

- a. Field Examination: For dimensions, coating, holes hammer test.
- b. Laboratory Tests: Certified test reports by foundry.

21. Polyethylene Pipe

Examination at the site, as practicable, per ASTM or other designated specification plus certified test reports from the supplier. Testing shall be performed in accordance with the procedure outlined in ASTM D 2513.

\*\*\*\*\*

### SECTION 3

#### CONCRETE AND REINFORCING STEEL

1. Scope

This Section covers the materials, mixing, transporting, and placing of all concrete and reinforcing steel including all labor, materials, and equipment.

The provisions of Section 2, Paragraph 2. Cost of Tests and Selection of Testing Agencies applies to this Section of these Detailed Specifications.

Where brand names or manufacturers are used in this Section, it is not intended that the use of products of equal quality and function by other manufacturers be prohibited. Concrete admixtures may be as furnished by Master Builders, Grace Construction Materials, SIKA Chemical Corporation, or approved equal. Concrete forms and accessories may be furnished by Universal Form Company, Dayton Sure-Grip and Shore Company, Heckman Building Products, or equal.

2. Reference Codes and Standards

All work covered by this Section of these Detailed Specifications shall be performed in accordance with the applicable portions of the following American Concrete Institute (ACI) and Concrete Reinforcing Steel Institute Standards (CRSI), as modified in this Section.

<u>ACI 224.3R:</u>	“Joints in Concrete Construction”
<u>ACI 301:</u>	“Specifications for Structural Concrete”
<u>ACI 302.1R:</u>	“Guide for Concrete Floor and Slab Construction”
<u>ACI 305R:</u>	“Guide to Hot Weather Concreting”
<u>ACI 306R:</u>	“Guide to Cold Weather Concreting”
<u>ACI 315:</u>	“Manual of Standard Practice for Details and Guide to Presenting Reinforcing Steel Design Details”
<u>ACI 318:</u>	“Building Code Requirements for Structural Concrete”
<u>ACI 347R:</u>	“Guide to Formwork for Concrete”
<u>ACI 350:</u>	“Code Requirements for Environmental Engineering Concrete Structures”
<u>CRSI-MSP:</u>	“Manual of Standard Practice”

The most recent published version (as of the project bid date) of any standard listed in these Detailed Specifications shall apply.

3. Class of Concrete

Concrete shall be two (2) classifications as follows:

CLASS "A" - All concrete shall be Class "A" unless otherwise shown on the Plans. ALL reinforced concrete shall be Class "A". Class "A" concrete shall possess the following characteristics and/or proportions of materials.

Minimum Cement Content: 6.0 bags (564 pounds) per cubic yard.

**NO FLY ASH WILL BE ALLOWED**

Minimum 28-day compressive strength: 4,500 psi average of any three (3) cylinders selected by the Engineer.

Anticipated 28-day compressive strength: 5,000 psi plus.

Slump: Three and one-half (3½) to six (6) inches in walls and columns and piers. Two and one-half (2½) to five (5) inches in slabs, beams, and footings.

Admixtures: A retardant may be required where slow set is desired; where quick set is desired Portland Cement content of 6.2 bags may be required. Air entraining agents optional and subject to Engineer's approval. Additional special admixtures may be specified in subsequent sections of these Detailed Specifications.

CLASS "C" - Concrete used for anchors, kickers, and encasement for pipe lines, for subfoundations and mass footings, and for fill shall be Class "C". No concrete containing reinforcement shall be Class "C". Class "C" concrete shall possess the following characteristics and/or proportions of materials:

Minimum Cement Content: 5.0 bags (470 pounds) per cubic yard.

Minimum 28 day compressive strength 2,500 psi - average of any three (3) cylinders selected by the Engineer.

**NO FLY ASH WILL BE ALLOWED**

Slump: Five (5) to eight (8) inches for encasement. Two (2) to four (4) inches in subfoundations and sealing as per Paragraph 10.d. hereinafter.

Admixtures: None required.

4. Determination of Strength of Concrete

Compressive strength of concrete shall be determined by use of standard four (4) inch diameter by eight (8) inch test cylinders in accordance with ASTM C39 and C 31.

5. Concrete Design Mixes

An independent commercial testing laboratory, approved by the Engineer, shall prepare a design mix for each Class "A" and Class "C" concrete and submit five (5) copies to the Engineer for general approval of the proportions and materials. The design mix shall be accompanied by the quality tests of the materials which are proposed in accordance with Section 2. Testing and Control of Materials, Paragraphs 5, 8, 9, and 10 of these Detailed Specifications. The sources of supply and the producer of the concrete, if a ready-mix plant, shall be subject to all the requirements of Section 2. Testing and Control of Materials, and particularly to Paragraph 3. Sources of Supply, thereof. After general approval of the materials and proportions the tests required in Paragraph 10. Advance Tests of Concrete Design Mix(es) of Section 2 shall be submitted for approval. No concrete may be placed prior to submission and approval of the design mix and of the test results. The cost of obtaining an approvable concrete mix will be paid for by the Contractor.

6. Materials for Concrete

a. Portland Cement

Portland Cement shall be of American manufacture and shall conform to the "Standard Specifications for Portland Cement" (ASTM C150), of the American Society for Testing and Materials and shall be Type II with an equivalent alkali ( $\text{Na}_2\text{O} + 0.658 \text{K}_2\text{O}$ ) content of less than 0.60 percent and shall have been shipped from the mill not more than three (3) months prior to incorporating into the work unless specifically waived in writing by the Engineer. For job site mixing all cement shall be in sacks. FLY ASH IS NOT AN ACCEPTABLE SUBSTITUTE FOR PORTLAND CEMENT. PREMIXED BAG CONCRETE IS NOT AN ACCEPTABLE SUBSTITUTE FOR PORTLAND CEMENT.

b. Water

Water used in concrete shall be clear and free from objectionable substances such as oil, acid, alkali, vegetable matter, clay, or silt. Water of doubtful quality shall be tested in briquettes which shall reach a strength equal to that of similar briquettes made with water of known satisfactory quality.

c. Admixtures

An air entraining admixture equal to Master Builders AE200, Darex A.E.A. or Aermix, meeting the requirements of ASTM C260 for Air Entraining Admixtures may be used but is not required. Use of such admixtures is subject to the approval of the Engineer.

The amount of air-entraining admixture to be used will be determined by the percent of air entrained in the concrete. The limits of air will be five (5) percent plus or minus one (1) percent.

The concrete when an approved air entraining agent is used shall have a reduction in weight of not more than three (3) to six (6) pounds per cubic foot as compared with concrete of the same consistency and cement content made without the use of the agent. The specified cement factor shall be maintained by adjusting the quantity of aggregate and water used to the satisfaction of the Engineer. Reduction in the twenty-eight (28) day strength as specified will not be permitted. The use of any other admixture will not be permitted without the written consent of the Engineer as to the admixture to be used and its proportion in the mix.

d. Fine Aggregate

Sand for concrete shall consist of clean, hard, durable uncoated particles, free from lumps of clay, soft or flaky material, loam, and organic matter. In no case shall fine aggregate containing lumps of frozen material be used. Fine aggregate containing appreciable quantities of mica, shale, slate, or other soft grains shall not be used. It shall not contain more than two (2) percent by weight of material which may be removed by the elutriation test. Sands which do not pass the standard colormetric tests shall not be used unless it can be shown that the failure to pass is caused by particles of lignite or coal. Fine aggregate shall conform to ASTM C33 with gradation as follows:

<u>Screen</u>	<u>Percent Passing</u>
No. 4	95 -100
No. 16	45 - 95
No. 50	10 - 30
No. 100	2 - 10

ONLY NATURAL RIVER SAND OR SPECIALLY APPROVED  
MANUFACTURED SAND SHALL BE USED.

e. Coarse Aggregate

Unless otherwise specified, coarse aggregate may be either crushed limestone, or crushed gravel. Coarse aggregate shall show no evidence of disintegration, and the weighted percentage of loss shall be not more than ten (10) percent by weight when subjected to five (5) alternations of the sodium sulphate test for soundness. It shall be composed of clean, hard, durable, uncoated particles free from deleterious matter. Except for gradation, coarse aggregate shall conform to the requirements of ASTM C33. The coarse aggregate shall meet the following grading requirements.

Passing 1 1/2" square laboratory sieve	-	100%
Passing 1" square laboratory sieve	-	90 - 100%
Passing 3/4" square laboratory sieve	-	50 - 75%
Passing 3/8" square laboratory sieve	-	10 - 25%
Passing No. 4 square laboratory sieve	-	0 - 5%

7. Proportioning of Materials for Concrete

During formulation of the design mix the proportions of aggregate to cement for the grade of concrete specified shall be such as to produce concrete of proper workability. The proportion by dry weight of fine to combined aggregates shall be controlled between limits of thirty (30) to forty-five (45) percent as directed by the Engineer, but the mix shall be so controlled as to use the minimum fine and the maximum coarse aggregate which will give a satisfactory and workable mix.

Measurement of cement, fine and coarse aggregate for all classes of concrete shall be by direct weight upon an approved type of scales. Water shall be accurately measured in gallons by equipment accurate to plus or minus five (5) percent.

The weight of cement in unopened sacks as packed by the manufacturer will be considered to be ninety-four (94) pounds per sack. The method of measuring the water shall be accurate and readily adjustable so that the proper ratio of water and cement in each batch may be secured. It is the intention of the Engineer to control rigidly the quantity of water in each mix and to get the densest possible concrete. The Engineer may require calibration of weighing equipment. Equipment for measuring water shall be checked and adjusted daily.

8. Source of Supply of Concrete

a. General

Concrete to be placed in the work may be proportioned and mixed by the Contractor on the site of the work or may be proportioned and mixed in a "Ready-Mix" central plant. Either plant shall be subject to the Engineer's approval of equipment and adequacy prior to the commencement of concrete placement operations. Such approval may be withdrawn by the Engineer if the concrete becomes non-uniform or for other reasons. In the case of such withdrawal of approval the Contractor shall either cause corrections necessary to obtain another approved source.

b. Mixing on Job Site

When small quantities of concrete are required at remote sites or the travel time from a ready-mix plant is deemed excessive or an approvable ready-mix plant is unavailable, the Engineer may approve job site mixing. The Engineer will require what is deemed adequate mixing and quality control equipment.

c. Mixing at a Central Plant

The name and location of the proposed plant and its sources of materials shall be submitted to the Engineer for approval. The Engineer may inspect the plant facilities and proposed mixer trucks and make a determination as to whether they are adequate to meet the quality control required. The Engineer's determination in this case will be FINAL and BINDING. The concrete shall be mixed and handled in accordance with the requirements of ASTM C94 except as otherwise specified herein. During the period of placing concrete the Engineer shall be afforded free access to the plant for such examinations as the Engineer deem necessary including the stationing of a separate resident project representative at the plant during batching operations if deemed desirable.

(1) Loading Tickets

Loading tickets shall be initialed by the "weight man" stating (1) the Class of concrete, (2) the name of the project, (3) the time of the batching, and (4) the batch weights of each material including water. When the mixer truck arrives on the job site a copy of the ticket shall be given to the resident project representative BEFORE the concrete is placed. Any additional materials added shall be noted.



(2) Transporting

Concrete shall be transported only in approved mixer trucks which will mix the concrete enroute. In extreme hot weather, when approved by the Engineer, the required amount of water may be added upon arrival of the truck at the job site in order to avoid pre-set of the mix enroute. Such approval requires close cooperation of all concerned and will be given only if equipment to accurately measure the water is available and only if strength and slump tests are found to be uniform; approval may be withdrawn for any reason including lack of cooperation. Concrete which reaches the job in a pre-set condition or fails to meet slump requirements will be rejected and shall be removed from the job site. No retempering with water or any other admixture will be allowed except in special emergencies and under the conditions set in Paragraph 9. Alteration of Concrete Slump (Retempering).

9. Alteration of Concrete Slump (Retempering)

ANY ALTERATION OF CONCRETE IS TOTALLY THE CONTRACTOR'S RESPONSIBILITY.

The concrete shall be mixed only in such quantities as required for immediate use, and shall be used while fresh and before initial set has taken place. The addition of water or some other plasticizer (sometimes called retempering) to a ready-mix truck at the job-site or such addition at any place more than ten (10) minutes after the original water charge has been added and mixing commenced is strictly prohibited except as provided herein. Any concrete which arrives on the job in which initial set has begun shall be wasted and not used in the work.

At the request of the Contractor, the Resident Observer may permit water and Portland cement to be added at the rate of twelve (12) gallons of water per sack of cement. If Portland Cement is not available without too great a time delay the Contractor may add up to one (1) gallon of water per cubic yard at his own risk.

If concrete arrives on the job too wet the slump may be altered by adding Portland cement and thoroughly mixing.

Any concrete which is altered shall have double the specified number of cylinders taken after said alteration and no work shall be added onto the pour in question until the quality is assured.

10. Placing of Concrete

a. General

All concrete shall be placed in daylight or daylight conditions approved by the Engineer and ONLY AFTER the Engineer's representative has been notified and has inspected and approved the placement of reinforcing steel and the general condition of form work.

All water and accumulated debris shall be removed from forms and observation holes shall be left in wall forms near the bottom for such purpose. For footings and on-grade slabs water shall be diverted or otherwise removed. For walls, beams, columns, and supported slabs the forms shall be wetted with water so as to tighten joints. Runways, where used, shall be independently supported so as to prevent disturbance of the forms.

CONCRETE WITHIN ANY UNIT OF WORK BETWEEN CONSTRUCTION JOINTS SHALL BE PLACED CONTINUOUSLY TO PREVENT "COLD JOINTS". New concrete shall be placed AGAINST each succeeding batch so as to build up a continuous monolithic "pour".

b. Cold Weather Placing of Concrete

No concrete shall be placed when the air temperature in a shaded area away from artificial heat is 40°F and falling. Concrete may be mixed and placed under the conditions set forth herein if the air temperature in the shade is 35°F and rising provided the Contractor makes provisions for heating to maintain 45°F and there is a U. S. Weather Bureau forecast for 45°F or above. When the air in the shade falls below 50°F the mixing water shall be heated (Maximum 140°F) so that the temperature of the concrete when deposited is between 60°F and 75°F. Several thermometers shall be maintained by the Contractor at the site of the work and placed as directed by the Engineer.

The Contractor shall supply such heating equipment as vented stoves and/or salamanders as are necessary to keep the temperature of the air surrounding the concrete from falling below 45°F until test specimens indicate the concrete has attained a compressive strength of 2,500 psi or greater or for a period of five (5) days. The Engineer may require additional heating units to be placed in operation if in the Engineer's opinion the concrete might be endangered by an additional drop in air temperature. When the required heating period has expired the concrete shall not be allowed to cool at a rate faster than 1°F per hour.

c. Hot Weather Placing of Concrete

When the temperature of the air exceeds 90°F or the average temperature for the period of placement exceeds 85°F or is predicted by a U.S. Weather Bureau forecast to exceed said limits special precautions are required. The temperature of the concrete shall not be allowed to exceed 90°F. Ice shall be substituted for mixing water prior to the addition of the other materials to mixer in order to maintain temperature. The ice shall be accurately weighed (8.34 pounds = 1 gallon) prior to its being placed in the mixer and the remaining mixing water reduced correspondingly. The temperature shall not be reduced below 65°F.

The maximum time allowed in the mixer by ASTM C94 (either three hundred [300] revolutions or one and one-half [1½] hours whichever occurs first) shall be considered the acceptable maximum at air temperatures between +45°F and +70°F. The following maximum allowables shall apply at various temperatures:

<u>Average Air Temperature</u>	<u>Maximum Time or Revolutions</u>
45°F - 70°F	1½ hours or 300
70°F - 80°F	1 hour or 200
80°F - 90°F	45 min. or 150
90°F - 100°F	30 min. or 100
100°F	No placing allowed

Extreme care shall prevail in the pouring of thin slabs and other thin sections. All forms, reinforcing steel, and/or subgrades shall be wet with cool water as shall all mixers, chutes, etc. immediately prior to concrete placement. No puddles of water shall be present at the time of placement.

d. Placing Concrete in Foundations

Whenever possible all foundation excavations shall be pumped dry and concrete deposited in the open. If it is not possible to proceed in this manner, a seal of concrete of sufficient thickness to resist any possible uplift shall be deposited under water in accordance with special directions of the Engineer. After the seal has set sufficiently, the foundation shall be pumped out; and the balance of the concrete placed in the dry.

e. Placing Concrete in Forms

Concrete shall be conveyed as soon as possible after mixing to the place in which it is to be deposited. The method and manner of placing shall be such as to avoid the possibility of segregation or separation of the aggregates or the displacement of the reinforcement. The concrete shall

be deposited so as to bring the construction up level and during the process, it shall be vibrated, rammed, spaded, or agitated by satisfactory tools so as to produce a compact concrete of maximum density with all spaces or voids filled and presenting a smooth, unbroken surface, free from coarse aggregate to exposed honeycomb spaces when the forms are removed.

f. Pumping or Chuting Concrete

If concrete is conveyed by pumps or chutes, the equipment shall be of such size and design as to insure a practically continuous flow. The slope of the chute or the design of the conveyance tubes shall be such as to allow concrete of a satisfactorily dry consistency to flow without separation of the ingredients. The chute or tube shall be thoroughly flushed with water before and after each run, discharging outside of the forms. Should stoppage occur in the chute or tube during concreting and the use of water be required to clean it, the water and all material removed from the chute or tube shall be wasted outside the forms. If, in the opinion of the Engineer, the arrangements for placement are such as to preclude the securing of watertight, smooth, dense concrete in any portion of the work, other and satisfactory means of transporting concrete shall be employed by the Contractor.

g. Vibrating Concrete

All concrete shall be vibrated in the forms as it is placed with mechanical internal vibrators maintaining 5,000 impulses per minute and approved by the Engineer. At least one (1) extra vibrator in operating condition shall be maintained at the job site in case of emergency.

11. Curing of Concrete

a. General

All concrete shall be protected from too rapid drying or curing by the covering of surfaces with burlap, curing compound as per ASTM C309, Type 1, or other suitable means immediately after finishing, concrete shall be kept moist for a sufficient period of time to insure satisfactory curing as directed by the Engineer, normally three (3) consecutive days.

b. Cold Weather Curing

If concrete is placed in cold weather the Contractor shall provide the necessary heat to insure that the temperature of the air immediately surrounding the fresh concrete does not drop below 45°F at any time, at any place, and that the concrete is uniformly kept warm until the concrete

has obtained a compressive strength of 2,500 psi or greater for at least five (5) days. The variations in temperature shall not exceed 10°F and no hot air shall be allowed to blow directly upon the fresh or curing concrete. The surfaces shall be protected from frost by covering with suitable blankets at any time the temperature is forecast to drop below 50°F.

c. Hot Weather Curing

During the curing of concrete in hot weather all surfaces shall be kept covered with burlap sacks or polyethylene and kept moist for a period of five (5) days after placing, after which the protective covering shall be allowed to gradually dry out.

The most extreme care shall be exercised to maintain a moist surface on slabs during the first twenty-four (24) hours after placement, and the Engineer, during periods of low humidity compounded by surface winds, may require continual wetting of the surface for a period of twenty-four (24) hours. After the first twenty-four (24) hours the surface shall be wet down when work is begun in the mornings and also at intervals during the day if required by the Engineer and left wet in the evenings.

12. Joints in Concrete

a. General

The placement of concrete shall be as shown on the Plans and/or approved "concrete placing plans" between construction joints. In general a unit shall not exceed thirty (30) feet in each direction nor more than nine hundred (900) square feet although the Engineer may approved larger pours when same are submitted in five (5) copies under the same procedure outlined for shop drawings and are to be considered as a shop drawing.

Vertical construction joints shall be provided at intervals of thirty feet (30') or less from corners and between construction joints on walls enclosing water holding basins above grade and dry spaces below grade. Horizontal construction joints shall be provided at intervals of thirty feet (30') or less in walls enclosing dry spaces below grade. Structural slabs on grade reinforced with deformed bars may be placed in pours of any dimension desired between construction joints.

Where a construction joint is made, laitance, all weak concrete, and foreign matter shall be removed and the concrete roughened.

On all joints except "expansion joints" the reinforcing shall be set to extend into subsequent sections of construction so as to make the work a

monolith. JOINTS SHALL NOT BE MADE EXCEPT AS THE ENGINEER MAY INDICATE, APPROVE, OR DIRECT TO PRESERVE THE STRENGTH, FACILITY OF PLACEMENT, OR WATERTIGHTNESS OF THE STRUCTURES. In general, the locations of the joints are shown on the Plans; but these may be changed if the Contractor requests and the Engineer approves. A period of at least forty-eight (48) hours shall elapse between the placement of adjacent concrete units or pours.

b. Watertight Expansion Joints

An expansion joint is defined as a joint specially constructed to allow movement as shown on the Plans. Expansion joints shall be constructed in accordance with the details shown on the Plans utilizing PVC waterstop, asphalt expansion joint filler, and SIKAFLEX 2c NS sealant or equal, and shall be watertight in water holding structures or dry wells. The expansion joint filler shall be the asphalt type conforming to the requirements of ASTM D994, W. R. Meadows, Inc. or equal. The exterior sealant shall be a two (2) part polysulfide rubber joint sealant conforming to the requirements of ASTM C920 for Class 25 sealants. The filler shall be applied so as to prevent "tracking" if accidentally stepped on.

c. Joints in Footings and Walls

Construction joints in footings and walls shall be located across areas of low shearing stress and shall be provided with keyways. Keyway details shall be as shown on the Plans or in special cases as directed. Waterstops shall be provided where shown on the Plans.

Expansion joints shall be located where shown on the Plans using the details of construction shown on the Plans.

d. Joints in Slabs and Beams

Construction joints shall be located near the middle of spans of slabs, beams, or girders; unless a beam intersects a girder at this point, in which case the joints in the girders shall be off-set a distance equal to twice the width of the beam. In this case, provision shall be made for shear by use of inclined reinforcement. Keyways shall be provided as shown on the Plans.

Expansion joints shall be located where shown on the Plans using the details of construction shown on the Plans.

e. Waterstops and Watertightness

Dry wells and structures housing equipment shall be watertight with no visible leaks and no accumulation of water. Any visible leaks shall be repaired to the satisfaction of the Engineer. Waterstops shall be polyvinyl chloride (PVC) and shall be of the configuration/type shown on the Plans. Keyways with eight (8) inch wide PVC waterstops for construction joints shall be used where such joints are shown. All PVC waterstops shall be installed as per the manufacturer's recommendations and shall be welded watertight.

Certain waterstops may be shown on the Plans or other material for special reasons.

f. Mastic Joints

Where joint sealer or mastic joint is noted on the Plans, the joints shall be sealed with the material designated on the Plans. All materials shall be installed in strict accordance with the manufacturer's instructions, and under the supervision of a qualified representative of the manufacturer. All surfaces and slots in concrete shall be provided as required by the manufacturer of the joint material.

g. Control Joints in Non-Reinforced, Non-Structural Slabs on Grade

Control joints in slabs on-grade which are reinforced with welded wire fabric only shall be saw cut and shall be a minimum of one-eighth inch (1/8") wide by one-fourth (1/4) the section in depth. Sawing of control joints shall be completed between twelve (12) and twenty-four (24) hours after finishing of the concrete surfaces. Timing of saw cutting shall be such that the slabs have sufficiently cured where no dislodging of aggregate occurs during the sawing operations.

The spacing of control joints and/or construction joints in slabs on grade shall generally not exceed fifteen feet (15').

Control joints in sidewalks shall be formed by tooling a groove downward from the surface with a one-fourth inch (1/4") edging tool. Spacing of control joints shall be equal to width of sidewalk.

h. Isolation Joints

Isolation joints to separate slabs from column footings, intersecting walls, etc. shall be provided where shown on the Plans. Isolation joint material shall be one-half inch (1/2") thick by the full depth of the slab, unless

otherwise noted on the Plans, and shall meet the requirements of ASTM D1994 for bituminous type performed joint filler.

Isolation joints, where shown on the Plans, separating concrete sidewalks from structures, concrete curbs, *etc.* shall be one-half inch (1/2") thick by the full depth of the sidewalk.

i. Joint Sealant

Where joint sealant is noted on the Plans and the joint sealant material is not designated, the joint sealant shall conform to the requirements of ASTM C1516 for cold application type concrete joint sealer.

13. Non-Shrink Grout

Non-shrink grout shall be used where called for on the Plans or required to insure watertightness. The proportions of the non-shrink grout mix shall be:

15 pounds Embecco or equal  
100 pounds Portland Cement  
100 pounds sand  
150 pounds pea gravel (may be omitted)

14. Forms for Concrete Work

a. General

If required by the Engineer, forming plans shall be submitted by the Contractor and approved by the Engineer before the forms are on the work. The Contractor may submit a plan or schedule for forming for the Engineer's consideration. The Engineer's approval of the Contractor's method of forming will be for the benefit of the Contractor and will be based on the acceptability of the finished work; in no case will the Engineer pass on or be responsible for the structural adequacy of the Contractor's forms, false-work, or other construction procedures.

Forms shall be substantial and sufficiently tight to prevent leakage of mortar. They shall be properly placed or tied together so as to maintain position and shape and insure safety to workmen and passersby. Temporary openings shall be provided where necessary to facilitate cleaning and observation immediately before depositing concrete. CONCRETE SHALL NOT BE PLACED IN ANY FORM UNTIL THE FORM AND THE RESTEEL IS OBSERVED BY THE ENGINEER. Such Engineer comment or approval does not apply to the structural integrity of the framework which is the total responsibility of the Contractor. The Contractor shall be completely responsible for the strength and adequacy



of the form work and shall save the Owner and/or Engineer harmless from any claims arising therefrom for any reason.

b. False Work

All false work shall be solely the Contractor's responsibility as to strength, line, and grade, *etc.*; but the Engineer may disapprove work which is unworkmanlike, or in the opinion of the Engineer, will not yield the finished product required.

c. Material for Forms

The forms for the outside face of all exposed surfaces shall be of not less than one and one-half (1½) inch tongue and grooved lumber dressed on both edges and on the face next to the concrete or three-fourths (¾) inch plywood panels unless otherwise shown on the Plans or specifically permitted by the Engineer. Forms for all other concrete work may be constructed with one (1) inch by six (6) inch tongue and grooved sheathing or one (1) inch ship-lap. Where shown on the drawings or required in these Detailed Specifications, or by the Engineer, forms for all exposed walls (both inside and outside) shall be constructed of three-fourths (¾) inch plywood which, in all cases, must be approved by the Engineer.

Moldings and the ornamentation shown on the Plans shall be formed with wood or metal molds. The width of all boards used for such work shall be approved by the Engineer.

d. Unlined Forms

Unlined forms may be used on unexposed surfaces of walls, slabs, columns, and beams unless otherwise specified herein or as shown on the Plans. Form boards shall not be re-used in contact with exposed surfaces unless they are thoroughly cleaned and oiled and approved by the Engineer.

e. Lined Forms

Where specified herein or where shown on the Plans, plywood panel or lined forms will be used for certain portions of concrete masonry structures. Where lined forms are used, the lining shall be of fiber board or plywood which must, in all cases, be approved by the Engineer. All lining materials shall be used in as wide pieces as a single width of fiber board. The lining material shall be nailed to the backing beginning at the center of the board and working toward the edges to prevent buckling. Cigar box nails or similar nails with flat heads shall be used to attach lining material to forms. The edges of the linings shall be butted tight together,

and joints between the sheets shall be filled with a compound of litharge or Rutland Patching Plaster, or approved equal. Lining material may be re-used if it is satisfactorily cleaned and approved by the Engineer.

The smooth side of the lining materials shall be placed next to the concrete surface where smooth surfaces are specified; where granular surfaces are indicated or specified, the rough surfaces of the lining materials shall be placed next to the concrete.

f. Steel Forms

The use of steel forms may be used when approved in writing by the Engineer. Ties used with steel forms shall be of the type designed to remain permanently in place and conform to the requirements for form ties hereinafter. Steel forms, if used, shall be placed under the direction of a trained and competent representative of the supplier and the Contractor shall be totally responsible for their structural integrity.

g. Form Ties

Approved form ties shall be used for all wall construction. The ties shall be of the type that snap back in the wall, or permit removal of the tie ends. Ties shall be adjustable to permit tightening of forms, and of such type that will require a minimum amount of pointing with no metal closer than one-half (1/2) inch from face of wall. No ties will be permitted that require more than one and one-half (1½) inch for pointing. REMOVAL OR PULL-OUT TYPE TIES WILL NOT BE PERMITTED UNDER ANY CIRCUMSTANCES. Form ties with three-fourths (3/4) inch wood concrete snap ties shall be as manufactured by the Universal Form Company of Chicago, Illinois, or approved equal.

h. Form Release Agents

All forms that are not restricted by the form manufacturer from application of a form release agent shall receive a volatile organic compound (VOC) compliant, non-staining, reactive, architectural application form release agent. The form release agent shall be applied in accordance with the manufacturer's instructions. Form release agents shall be Duogard as manufactured by W. R. Meadows or equal.

i. Removal of Forms

Forms shall not be removed until the concrete has attained a strength sufficient to support itself and the superimposed loads. Under normal curing conditions (average temperature 50°F or above) the forms may be removed after following minimum time has elapsed.

Detailed Specifications  
January 2024

Floor slabs, beams, and girders	- 10 days
Columns, pedestals, and sections less than 12 inches thick	- 4 days
Wall lifts (12 inches thick) under 10 feet	- 2 days (48 hrs. min.)
Wall lifts (12 inches thick) over 10 feet	- 3 days (72 hrs. min.)

In cold weather forms shall not be removed from any work when the danger exists of freezing the concrete or otherwise damaging the surface. Whenever a question exists as to removal of forms, the forms shall not be removed until a standard cylinder cured on the site in a manner similar to the work represented has attained a compressive strength of 3,000 psi.

The use of the foregoing table shall in no way relieve the Contractor of its responsibility for the safety and integrity of the structure.

15. Floor Drains, Sleeves, and Inserts

The Contractor shall be responsible for placing all sleeves, floor drains (which shall be placed one (1) inch low and the floor sloped thereto), wall castings, step nosing, and other inserts in the concrete walls and floors in their proper positions. If for any reason said sleeves, wall castings, and/or other inserts are not delivered prior to pouring, the Contractor shall box out for same in a manner acceptable to the Engineer. It shall then become the responsibility of the Contractor to place same and make a watertight closure of the openings in a manner satisfactory to the Engineer.

16. Slabs on Grade

a. Subgrade Preparation

Subgrade shall be prepared and constructed in accordance with "Guide for Concrete Floor and Slab Construction", ACI 302.1R and as hereinafter stipulated.

The subgrade shall be compacted in the presence of the Engineer immediately prior to the fine grading operation. All soft or unstable material detected during the final compacting shall be cut out and the area reworked to provide the specified density.

After final compacting, a six inch (6") crushed stone base shall be constructed as required to obtain the specified slab thickness within a tolerance of plus or minus one-fourth inch (1/4"). All ruts and depressions shall be filled to eliminate any abrupt changes in slab thickness.

A SIX (6) MIL POLYETHYLENE VAPOR BARRIER MEETING THE REQUIREMENTS OF ASTM D2103 SHALL BE PLACED OVER THE PREPARED CRUSHED STONE BASE PRIOR TO PLACING CONCRETE FOR THE SLAB.

b. Slab Placement

Materials and construction requirements relating to slabs on grade shall be in accordance with provisions outlined in this Section of the Specifications, in accordance with the "Guide for Concrete Floor and Slab Construction", ACI 302.1R and as hereinafter stipulated.

Slabs on grade which are not shown to pitch to drain shall be constructed to a uniform plane at the elevation shown on the Plans. Tolerance of dead-level slabs shall be plus or minus one-fourth inch ( $\pm 1/4"$ ) in ten feet (10') ( $F_{F22}$  and  $F_{L22}$ ). Slabs at floor drains shall be finished with a four foot (4') diameter dish with center of dish one inch (1") below floor level.

Reinforcing steel shall be cut at isolation joints and expansion joints. Wire mesh reinforcement and bar reinforcement shall be placed as shown on the Plans.

Slabs shall be constructed in a strip pattern. The width of each strip shall coincide with the distance between column lines. Construction joints shall occur at the column lines in buildings.

Concrete shall be discharged as close to its final position as possible. Concrete shall be screeded with hollow metal straightedges, vibrating screeds or roller screeds. After initial screeding, low spots shall be filled with additional concrete placed by shovel and these areas shall be rescreeded. Screeding must be completed before any excess water or bleeding water is present on the surface of the concrete.

Immediately after screeding and before any excess moisture or bleeding water is present on the surface of the concrete, surfaces shall be bull floated with wood floats to eliminate ridges and fill in voids left by straight-edging operations.

Concrete shall be floated after it has stiffened to the point where foot pressure can be sustained with a maximum of one-fourth inch ( $1/4"$ ) indentation. Floating shall be performed, utilizing power floats or trowelling machines fitted with float shoes. Surfaces inaccessible to power driven machines shall be hand floated, utilizing wood, magnesium or aluminum hand floats.

c. Curing

(1) Interior Floor Slabs

Interior floor slabs shall be cured with a membrane curing compound designed to cure, seal, harden, and dustproof. This compound shall be applied within one-half ( $\frac{1}{2}$ ) hour after completion of finishing operations and/or immediately after disappearance of the "sheen" of surface moisture. Slab surfaces shall be uniformly coated at the rate recommended by the manufacturer. Application of material shall be by means of a roller or spray gun. If the floor slab is constructed prior to completion of the building envelope, floor surfaces shall be covered with curing sheets meeting the requirements of ASTM C171. Sheets shall be securely anchored and maintained in place for a minimum of seven (7) days.

(2) Exterior Slabs and Water Holding Basin Floor Slabs

Exterior floor slabs, slabs on grade not requiring special coatings, and floor slabs of water holding basins shall be cured with a membrane curing compound designed to cure and seal. The curing and sealing compound shall be a hydrocarbon, resin-based compound meeting the requirements of ASTM C309, Type 1, 1D, Class A and Class B. This compound shall be applied within one-half ( $\frac{1}{2}$ ) hour after completion of finishing operations in accordance with the manufacturer's instructions. Slab surfaces shall be uniformly coated at the rate recommended by the manufacturer. Curing and sealing compound shall be CS-309-30 OTC by W. R. Meadows or equal.

As an alternative to use of membrane curing compound, the exterior slab may be completely covered with burlap and continuously soaked for ninety-six (96) hours after placing with a potable water sprinkler system.

17. Aluminum Safety Treads

The Contractor shall furnish and install on the leading edge of stairs, steps and landings nosings which shall be eight (8) inches less than the width of the surface to which said the nosing is attached (four [4] inches each side). The nosings shall be three (3) inches wide of the non-skid type equal to Wooster Products Type 101 alumogrip abrasive cast aluminum. Attachment shall be with concealed anchors on new work (for renovations use stainless steel screws). The installations shall be such that the top of nosing is flush with the top of the slab to which it is attached.

18. Concrete Finish

a. Floor Slabs

The concrete floors of all structures shall be finished monolithically with an allowable variation of one-eighth (1/8) inch in ten (10) feet transversely and longitudinally.

Concrete floor slabs on grade shall be placed over a well tamped and compacted subgrade. Form all recesses for thickened slabs, as shown on the Plans and thoroughly compact stone. Lay vapor barrier of six (6) mil (0.006 in.) thickness polyethylene over fill. Vapor barrier shall follow the contour of the thickness of the slab.

All floor drains shall be set one (1) inch lower than grade and the slab pitched thereto.

Slabs to receive quarry tile shall be finished by tamping the concrete with special tools to force the aggregate away from the surface; then screeded with straight edges and floated to produce a reasonably true and uniform surface.

b. Walls, Beams, Ceilings and Columns

(1) General

All concrete walls, ceilings, and beams shall be pointed; those which are to be exposed permanently to view, including the interior of basins to a point twelve (12) inches below the water line, shall be pointed and rubbed. If the surface is to be painted it shall be left smooth and all loose concrete rubbed away by use of a rough burlap sack or other effective method; if the surface is not to be painted it shall be rubbed as hereinafter specified. Foundation walls shall be rubbed to a point one (1) foot below grade on the outside. All projecting fins shall be removed from the concrete and holes left by form ties shall be pointed up.

(2) Pointing

After the specified curing times have elapsed, forms and form ties shall be removed and all depressions or imperfections inspected by the Engineer. After the Engineer has approved the general integrity of the work, all imperfections shall be wetted and repaired with non-shrink sand-cement mortar.

(3) Rubbing

After pointing has set, all surfaces requiring rubbing shall be kept wetted with water with a brush and rubbed with a No. 20 carborundum stone. The rubbing shall be continued sufficiently long to remove all marks and projections, producing a smooth, even surface without marked irregularities. The final rubbing shall be done with a No. 40 carborundum stone and continued until the entire surface is of smooth texture. After the rubbing has been finished, all excess particles shall be removed by brushing the surface with burlap. The finished surface shall be uniform in color and otherwise satisfactory to the Engineer.

(4) Coating

IF APPROVED by the Engineer in lieu of rubbing concrete, all structural cast-in-place concrete foundations, walls, beams, columns, roofs, ceiling and equipment foundations exposed to view and not identified or depicted on the accompanying Plans to receive any other finish or treatment, including the interior of all water holding structures to an elevation twelve inches (12") below the minimum normal water level and exposed exterior concrete walls to an elevation twelve inches (12") below finished grade, shall be coated as described hereinafter.

The coating shall be MasterSeal 584 or equal combined with water and MasterEmaco A660 or equal, both manufactured by Master Builders Solutions, or approved equal, in the proportions recommended by the product manufacturer for a trowel finish coating approximately one-eighth inch (1/8") to one-fourth inch (1/4") thick. The coating shall be applied according to the manufacturer's printed instructions including a "key coat" cured five (5) to seven (7) days followed by a final coat applied with a steel trowel and finished with a sponge float. All concrete coating described in this Paragraph shall be applied with a trowel finish, except that the coating to the underside of overhanging walkways may be applied with a brush finish. Application by spraying will not be allowed. All products used shall be those manufactured by Harris Specialty Chemicals, Inc., or approved equal.

The color shall be selected by the Owner.

c. Exterior Slabs

All walks, platforms, and exterior floors or slabwork shall have a broomed finish. After screeding to the required grade while the concrete is still

green, but has hardened sufficiently to bear the finisher's weight the surface shall be floated with a wood float to a true and even plane with no coarse aggregate visible. The slab shall then be evenly broomed with all strokes parallel to leave a workmanlike skid resistant finish.

d. Chamfer

All exposed edges shall be chamfered three-fourths (3/4) inch unless otherwise noted.

19. Watertightness

a. General

The Contractor is required to make watertight concrete in all structures holding water or solutions or dry wells or basements. All cracks and imperfections developing at any point in the work shall be thoroughly repaired in a manner satisfactory to the Engineer. When the concrete work has attained sufficient strength, the Contractor shall fill each basin or tank, or each compartment, with water, and shall repair any imperfections which cause the water level to fall more than one-half inch ( $\frac{1}{2}$ " ) in twenty-four (24) hours. All noticeable leaks in any portion of the work shall be repaired in any case, even if the preceding requirements as to watertightness are satisfied. THE CONTRACTOR MAY CONDUCT THIS WATERTIGHTNESS TEST EITHER BEFORE OR AFTER BACKFILLING EXTERIOR WALLS.

It is expected that with the proper precautions, a dense watertight concrete will be obtained. If concrete which passes the above requirements for watertightness has not been obtained, the Contractor shall, under the direction of the Engineer, furnish all materials and do all work necessary to produce watertight concrete structures.

All treatment of concrete necessary to fulfill these requirements for watertightness shall be done at the Contractor's own expense.

b. Dampproofing

The outer surface of all exterior concrete walls enclosing dry spaces (e.g. pits or structures housing equipment, valves or instruments) that is to be covered by backfill or by brick or decorative block shall be coated with an emulsion type asphalt dampproofing prior to backfilling or laying of brick. The dampproofing shall conform to ASTM D1227, Type 4 for brush-on application to concrete surfaces. Concrete structures containing water or wastewater do not require dampproofing.



Surfaces to receive dampproofing shall be clean and dry before application of dampproofing. Surfaces shall be primed in accordance with the manufacturer's recommendation. The dampproofing shall be applied uniformly at a rate of not less than thirty (30) pounds per one hundred (100) square feet.

Dampproofing shall be protected from damage until brick or decorative block is laid or backfill is placed. Concrete walls exposed to view after completion of construction shall not be waterproofed.

20. Defective Concrete

Concrete shall be so placed, compacted, finished and cured so as to form a dense, compact, impervious artificial stone with smooth exposed faces. Any part of the work found to be honeycombed, porous, or otherwise defective in the opinion of the Engineer shall be removed or replaced in whole or in part at the expense of the Contractor.

21. Testing of Concrete

In general, Section 2. Testing and Control of Materials of these Detailed Specifications, governs all testing.

The following tests and/or samples shall be taken in the field as work progresses:

a. Standard Slump Tests

Field slump tests shall be made by the Contractor, using an accurately made sheet iron test cone, in accordance with the provision of ASTM C143. At least one (1) slump test shall be made for each truck; the Engineer may require additional tests if he deems it necessary to insure the desired consistency of the concrete.

b. Concrete Compression Samples

During the progress of the work and for each different mix of concrete, test cylinders shall be made from each day's pour with a minimum of one (1) for each twenty-five (25) cubic yards or a maximum of one (1) from each batch or readymix truck load. The maximum requirement will be imposed only when the Engineer deems necessary due to wide fluctuations in the concrete quality. A minimum of three (3) cylinders will be required for each day's pour if the concrete is used in structures or otherwise in a load carrying capacity. Sidewalks, manholes, *etc.*, may require only one (1) cylinder if less than twenty-five (25) cubic yards per day is placed, and the quality remains sufficiently high in the opinion of the Engineer.

Detailed Specifications  
January 2024

Each cylinder shall be numbered and logged so as to adequately identify the location of the representative concrete in the structure.

The following "break" schedule for cylinders from the same pour will be used:

- |  |   |
|--|---|
| Where only one (1) cylinder is made    | - 28 days   |
| Where two (2) cylinders are made       | - one at 7 days<br>- one at 28 days                                       |
| Where three (3) cylinders are made     | - one at 7 days<br>- one at 14 days<br>- one at 28 days                   |
| Where four (4) cylinders are made      | - one at 7 days<br>- one at 14 days<br>- one at 28 days<br>- one reserved |
| Where over four (4) cylinders are made | - Same as four plus<br>reserve or as directed                             |

ASTM C31 shall govern with curing as required. The testing shall be done per ASTM C39.

22. Reinforcing Steel

a. General

Bar reinforcement and wire mesh reinforcement shall be furnished and tested in accordance with Section 2. Testing and Control of Materials. CERTIFIED MILL TEST REPORTS SHALL ALSO BE FURNISHED TOGETHER WITH AN AFFIDAVIT INDICATING THE ORIGIN.

b. Bar Reinforcement

Reinforcing steel shall conform to the requirements of ASTM A615 new billet steel, Grade 60, with deformations conforming with ASTM A615. An affidavit showing the heat numbers and origin shall be furnished.

All bars shall be lapped a minimum of thirty (30) diameters at splices unless a greater lap is shown on the Plans.

All detailing, fabrication, and erection of reinforcing bars, unless otherwise noted, shall be in accordance with the ACI "Manual of Standard Practice for Details and Guide to Presenting Reinforcing Steel Design Details" (ACI 315).

The Contractor shall furnish the Engineer with five (5) copies of shop drawings of reinforcing bars, and schedules showing all bends and special bars. These shop drawings and schedules must have the approval of the Engineer before shipment is made. The bars shall bear a designation on the drawings and in the schedule and shall be tagged with metal tags for identification. The Engineer's representative shall be afforded free access to the fabricating shops.

c. Wire Mesh Reinforcement

Wire mesh reinforcement shall conform to the requirements of ASTM A1064.

d. Openings

Openings twelve (12) inches and larger through concrete walls and slabs shall have a minimum of four (4) extra diagonal bars in each face of the wall or slab of the same size as the largest bar in the wall or slab. The length of extra diagonal bars at openings shall engage a minimum of forty (40) bar diameters each side of the opening unless space requires full bond to be developed by means of hooks.

e. Minimum Reinforcing Steel

If through an omission Class "A" concrete walls, slabs, and other concrete work are shown on the Plans to have no reinforcing, a minimum area of steel reinforcing equal to 0.0018 times the cross-sectional area of the concrete work shall be provided.

f. Storage and Protection

Steel reinforcement, either bars or mesh, shall be new stock free from rust scale and shall be stored above the surface of the ground upon platforms, skids, or other supports and protected from the weather. When placed in the work it shall be free from rust, dirt, scale, paint, oil, or other foreign matter which may reduce or destroy bond. A thin coating of red rust resulting from short exposures will not be considered objectionable when bars are placed in the work; but any bars having rust scale or a thick rust coat shall be thoroughly cleaned to the satisfaction of the Engineer, or shall be rejected and removed from the premises if ordered by the Engineer.

g. Placing and Fastening of Reinforcement and Inspection Thereof

Steel reinforcement shall be placed in the exact position as shown on the Plans and held securely in place during the placing of the concrete. All

reinforcement shall be wired together at intersections or as directed by the Engineer. Sheet metal or welded wire bar spacers shall be used for bars in all steps, walls, and beams. Chairs, or approved equal, shall be provided for the support of reinforcement of slabs and flat surfaces. When the reinforcement is placed in the work, it shall have a clean, fresh surface, free from dirt, scaly rust, mill scale, paint, oil or other foreign substances.

BEFORE ANY CONCRETE IS PLACED, THE ENGINEER SHALL HAVE EXAMINED THE PLACING OF THE STEEL REINFORCEMENT AND GIVEN PERMISSION TO DEPOSIT THE CONCRETE. CONCRETE PLACED IN VIOLATION OF THIS PROVISION MAY BE REJECTED AND THEREUPON SHALL BE REMOVED.

23. Concrete Repair Material

Where the repair of existing Portland cement concrete is noted on the accompanying Plans, the following procedures and materials shall be utilized to perform the repair.

All surfaces to be repaired shall be prepared as necessary to make them clean and structurally sound. The surface shall be cleaned by chipping, acid-etching, sandblasting and/or shot-blast cleaning methods to remove all dust, grease, paint, sealers and other foreign materials from the Portland cement concrete surface to be repaired. If acid-etching is used, the surface to be repaired shall be neutralized using a caustic solution and brushed prior to performing the repair. The Portland cement concrete surface to be repaired shall be kept damp for thirty (30) minutes prior to beginning the repair work but standing water shall not be allowed on the surface to be repaired.

The repair material shall be a two (2) component acrylic polymer modified concrete repair material. The material shall be mixed and applied in strict accordance with the manufacturer's written instructions. The concrete repair material shall be Patchcrete® manufactured by Lyons Manufacturing, Inc. or equal.

\*\*\*\*\*

## SECTION 4

### WATER LINES AND APPURTENANCES

#### 1. Scope

The work covered under this Section of these Detailed Specifications consists of the furnishing of all labor, materials, equipment and services necessary for the construction of the utility relocation for the City of Dayton, Tennessee. This construction consists of utility pipelines and all necessary appurtenances including, but not limited to, pipe, fittings, valves, disinfection, hydrostatic testing, seeding, and accessories. Materials are to comply with the “Safe Drinking Water Act”.

The quantities enumerated in the BID FORM are only general in nature and the Contractor shall avail himself to construct the utility pipelines complete as depicted on the plans. ADJUSTMENTS IN UNIT PRICES WILL NOT BE MADE IF THESE GENERAL QUANTITIES ARE NOT EXACT.

#### 2. Location of Utility Lines

The approximate location of the utility lines in relation to the Limits of Rights-of-Way, pavement, *etc.*, is shown on the Plans but not guaranteed. The location shown was chosen to minimize overall project cost with rock excavation, pavement replacement, crushed stone for traffic-bound roadway, *etc.*, considered. The final location as constructed may be varied by the Contractor with the approval of the Engineer, provided (1) the proposed location is within the permanent easement or right-of-way, (2) the proposed location is approved by the Owner or other agency or legal entity having jurisdiction, and (3) the effect lessens the project cost. The final location in any event may be varied by necessity due to construction conditions at the direction of the Engineer due to requirements of the Tennessee Department of Transportation, the City of Dayton, Bledsoe County, other agency or legal entity having jurisdiction.

#### 3. Pipeline Materials for Water Lines

##### a. General

The pipe for underground water lines shall be Class 350 ductile iron pipe or DR 21 polyvinyl chloride (PVC) water pipe with standard gasketed joints as indicated on the Plans.

b. Ductile Iron Pipe

(1) Materials, Manufacture and Joints

Ductile iron pipe shall be centrifugally cast, manufactured and tested in accordance with the ANSI/AWWA Standard C150/A21.50-02 for Ductile Cast Iron, Grade 60-42-10. The nominal wall thickness for each pipe size and Pressure Class shall be as follows:

<u>Size</u>	<u>Pressure Class</u>	<u>Wall Thickness (Inches)</u>
4-inch	350	0.25
6-inch	350	0.25

The pipe shall be manufactured and tested in accordance with the requirements of ANSI Specification A21.51.

Pipe shall be push-on type joint incorporating a single molded rubber ring gasket unless otherwise indicated and shall be furnished tar coated outside and the manufacturer's standard cement lined inside to comply with ANSI Specification A21.4.

(2) Joint Lengths and Joint Deflection

**Standard joint length shall be twenty (20) feet; however, shorter lengths may be used in order to achieve the alignment or grade required. The maximum allowable joint deflection for DIP pipe is 5 degrees (21 inches per 20-foot length, regardless of the layout shown on the Plans); in order to achieve the alignment or grade, shorter lengths or extra fittings will be required. The maximum joint deflection will be strictly enforced. Bending of the pipe will not be allowed.**

(3) Ductile Iron Fittings

All fittings for ductile iron pipe shall be Class 350 mechanical joint single gasket ductile iron conforming to ANSI/AWWA C153/A21.53 and shall meet the current requirements for the manufacturer's standards. Fittings shown on the Plans are intended to convey the general configuration, but the Contractor shall furnish all fittings required.

Each fitting shall be certified by the manufacturer to have been tested and to have met the requirements of the governing standard specifications.

**All fittings shall use thrust restraint devices in lieu of the standard glands. Thrust restraint devices shall be Series 1100 Megalug as manufactured by EBAA Iron, Inc. unless otherwise noted. Series 3800 Megalug as manufactured by EBAA Iron, Inc. shall be used to connect to existing ductile iron pipe with new polyvinyl chloride pipe as noted.**

All fittings shall be furnished tar coated outside and the manufacturer's standard cement lined inside to comply with ANSI Specification A21.4.

(3) Pipe Bedding and Backfill

See Paragraphs 8 and 12 of this Section of these Detailed Specifications.

(4) Testing

See Paragraph 19 of Section 2 of these Detailed Specifications.

(5) Markings

Each length of pipe and fittings shall have the following information plainly marked on the pipe's exterior:

- a. Nominal Size
- b. Class
- c. Manufacturer
- d. Independent Testing Laboratory Stamp
- e. Quality Control Code
- f. NSF (National Sanitation Foundation) Standard 61 Stamp Seal of Approval

(6) Restrained Joint Pipe

Ductile iron pipe with restrained joints shall be Class 350 and conform to the latest revisions of ANSI Specification A21.10, A21.11 and A21.51. The pipe shall be installed where shown on the Plans or directed by the Engineer and shall utilize American Fast Grip gaskets or approved equal.

c. Polyvinyl Chloride (PVC) Pressure Pipe

(1) Pipe Material

Polyvinyl Chloride pipe for water distribution shall be made from Type I, Grade 1 or 2, Polyvinyl Chloride plastic as defined in the latest revision of ASTM D1784, "Specifications for Rigid Poly (Vinyl Chloride) (PVC) Compounds and Poly (Vinyl Chloride) (CPVC) Compounds".

(2) Physical Properties

The pipe shall conform to and/or exceed the latest revisions of Commercial Standard CS-256 or ASTM D2241 "Standard Specification for Poly (Vinyl Chloride) (PVC) Pressure Rated Pipe (SDR-PR and Class T)" as it applies to Type I, Grade 1 or 2 Polyvinyl Chloride plastic pipe, DR 21, water pressure rating of 200 psi at 23°C (73.4°F).

(3) Joints

The joints for pipe 1 ½-inch size and larger shall be push-on joints designed so that the pipe and fittings may be connected on the job without the use of solvent cement or any special equipment. The push-on joint shall be single rubber gasket joint designed to be assembled by the positioning of a continuous, molded, rubber ring gasket in an annular recess in the pipe or fitting socket and the forcing of the plain end of the entering pipe into the socket, thereby compressing the gasket radially to the pipe to form a positive seal. The gasket and the annular recess shall be so designed and shaped that the gasket is locked in place against displacement as the joint is assembled. Details of the joint design and assembly shall be in accordance with the joint manufacturer's standard practice. The joints shall be designed so as to provide for the thermal expansion or contraction experienced with a total temperature change of at least 75°F in each joint per length of pipe.

(4) Lubricant

Lubricant furnished for lubricating joints shall be non-toxic, shall not support the growth of bacteria, shall have no deteriorating effects on the gasket or pipe material, and shall not impart color, taste or odor to water. The lubricant containers shall be labeled with the manufacturer's name or manufacturer's trademark and NSF Standard 61 Stamp Seal of Approval.



(5) Gaskets

Gaskets shall meet all applicable requirements of the latest revision of ANSI Standard A21.11.

Gasket dimensions shall be in accordance with the manufacturer's standard design dimensions and tolerances. The gasket shall be of such size and shape as to provide an adequate compressive force against the spigot and socket after assembly to effect a positive seal under all combinations of joint and gasket tolerances. The trade name or trademark, size, mold number, gasket manufacturer's mark, and year of manufacturer shall be molded in the rubber on the back of the gaskets.

Gaskets shall be vulcanized natural or vulcanized synthetic rubber. No reclaimed rubber shall be used. When two harnesses of rubber are included in a gasket, the soft and hard portions shall be integrally molded and joined in a strong vulcanized bond. They shall be free of porous areas, foreign material, and visible defects.

(6) Pipe Lengths

The pipe shall be furnished in nominal lengths of 20 or 38 feet. If 38-foot lengths are used, the pipe shall be supported at least every 10 feet of its length during all handling and special care shall be taken to avoid placing undue stress on the pipe during handling and any actions that may damage the bell or spigot ends of the pipe shall be avoided.

(7) Fittings

All fittings for PVC pipe shall be ductile or cast iron as specified in Subparagraph b. (3) of this Paragraph hereinbefore.

(8) Approval for Potable Water

The pipe and fittings shall conform to the Specifications of the National Sanitation Foundation Testing Laboratories, Ann Arbor, Michigan, and the pipe and manufacturer shall be approved by the Division of Water Resources, Tennessee Department of Environment and Conservation.

(9) Pipe Bedding and Backfill

See Paragraphs 8 and 12 of this Section of these Detailed Specifications.

(10) Marking of Pipe

As a minimum the pipe shall have the following data applied to each piece:

1. Nominal Size
2. Type of Material
3. SDR or Class (color coded)
4. Manufacturer
5. NSF (National Sanitation Foundation) Stamp Seal of Approval
6. Quality Control Code – Stamp Seal of Testing Agency

(11) Testing

The tests shall be performed in the manufacturer of PVC pipe by an independent testing laboratory as required in Section 2, Paragraph 17 of these Detailed Specifications.

**The manufacturer or testing agency shall report results of all tests to the Engineer.**

(12) Locator Device

A strand of #10 THNN Tracer Wire shall be positively connected to valves. #10 THNN Tracer Wire shall be placed in the ditch as a locator device positively connected at each joint of pipe. Locator tape shall be placed in the ditch approximately twelve (12) inches below grade as a locator device.

(13) Deflection and/or Bending of Pipe

The deflection shall not exceed that allowed by the manufacturer in the printed instructions. Bending of pipe will NOT be permitted.

4. On-Site Inspection of Pipeline Materials

Before allowing any pipe or fittings to be paid for as “stored material” the Engineer shall be afforded the opportunity to inspect and mark it on-site.

The inspection shall consist of a visual inspection for obvious cracks, improper markings or other defects and a dimensional inspection. The contractor shall furnish templates or other means of ascertaining the compliance of the pipe to the dimensional allowances in the governing specifications.

Rejected pipe or fittings will be painted with an orange or red “X” and the date. Such rejected materials shall be immediately segregated from acceptable pipe and shall be removed from the project within 14 days.

5. Alignment and Grades

Water pipeline alignments are established on the accompanying Plans in reference to topographical features, property boundaries and/or right-of-way boundaries. The final locations as constructed may be varied by the Contractor with the written concurrence of the Engineer provided the proposed location is approved in writing by the Tennessee Department of Transportation. The final location in any event may be varied by necessity due to construction conditions, or due to requirements of the Owner, property owner, or agencies or legal entities having jurisdiction.

**The Contractor shall be responsible for establishing the location of all property boundaries, right-of-way boundaries, pipe endwalls, box culvert wing walls, and proposed slope lines from which the horizontal alignment of the pipelines are dimensioned.**

Where depicted on the accompanying Plans in order to minimize the number of horizontal or vertical fittings and/or air release locations, the Contractor shall construct the pipeline in such a manner as to utilize the pipe manufacturer’s joint deflection allowance for ductile iron pipe at changes in horizontal and vertical alignment. **The manufacturer’s printed joint deflection for ductile iron pipe shall not be exceeded under any circumstance. This technique may require portions of the pipeline to be installed with extra depth of cover; extra payment will not be made to the Contractor for pipeline installation at such extra depth(s).**

Any apparent discrepancy or error discovered in horizontal and/or vertical control for the project shall be reported to the Engineer immediately. In the event of apparent discrepancies or conflicts, the Project Manager, Daniel G. Tribble, P.E., telephone: (615) 883-3243, shall be notified and his approval secured before proceeding.

6. Excavation for Pipeline Trenches and Appurtenances

a. General

Excavation on this project, whether earth or rock, is not a separate pay item but is to be merged into the price of the pipeline shown in the BID FORM. The excavation shall be carried to the depths indicated on the Plans and/or directed by the Engineer to permit proper bedding of the pipe.

The contractor, at his own expense, shall provide adequate facilities for promptly removing water from all excavations.

Unless otherwise indicated trenches shall be excavated in open cut to the depths shown on the Plans. Trenches shall be of the minimum width shown on a Detail on the Plans. Unless specifically authorized by the Engineer, trenches shall be excavated a minimum of 1 foot 6 inches plus the outside diameter of the pipe, at the level of the crown of the pipe.

Unless specifically directed otherwise by the Engineer or where required to uncover or determine the presence of underground obstructions, not more than three hundred (300) feet of trench shall be opened ahead of the pipe laying, and not more than two hundred (200) feet of open ditch shall be left behind the pipe laying. Before laying the pipe, the contractor shall open the trench far enough ahead to reveal obstructions that may necessitate changing the line or grade of the pipeline.

All barricades, lanterns, watchmen, and other such signs and signals as may be necessary to warn the public of the dangers in connection with open trenches, excavations and other obstructions shall be provided by and at the expense of the contractor.

The trench shall be straight and uniform so as to permit laying pipe to the proper lines and grades.

When so required, by the Owner through the Engineer, one-half of the pedestrian street crossings and pedestrian road crossings shall be excavated, then temporary bridges consisting of ½-inch steel plate shall be placed over the side excavated for the convenience of the traveling public; then the remainder of the excavation shall be carried out. All backfilled ditches shall be maintained in such a manner that they offer minimal hazard to the passage of traffic. The convenience of the traveling public and the property owners abutting the improvements shall be taken into consideration. All public or private drives shall be promptly backfilled or bridged.

In excavation for masonry and concrete structures including manholes, the required width shall be such as to permit forms to be constructed in the proper manner and to permit proper backfilling upon completion of the structures. Depth of excavation for footings shall be as shown on the Plans and/or as directed by the Engineer to obtain sufficient bearing.

All excavated material not needed for backfilling purposes shall be disposed of in a manner satisfactory to the Owner.

In all areas along highways or roadways where the pipeline is being laid in the pavement or in the right-of-way of the road, excavation during each day shall be limited to the footage of pipe that can be laid and the trench be backfilled so that minimal ditch is left open overnight in such areas.

All excavation shall be accomplished in accordance with applicable safety laws and regulations; the Engineer, as previously stated, does not assume responsibility of any degree or sort for acts of the contractor.

b. Unstable Trench Bottom Material or Undercutting

If wet, mucky and/or unstable or unsuitable material is encountered in a trench bottom, the Engineer may require additional excavation to insure a firm foundation for the pipe. In such cases, the trench bottom shall be brought back up to proper grade with bedding material as provided herein. Crushed stone (TDOT No. 67) is to be used for refill.

The Engineer shall determine when it is necessary to use such material and the contractor shall be responsible for calling such unstable trench bottom conditions to the attention of the Engineer.

c. Depths of Cover

The excavation for all pipelines shall be carried to the depths indicated on the Plans and/or directed by the Engineer to permit proper bedding, release of air from the pipe and to prevent "air-locking" or the trapping of air in high points. Trenches shall be opened to a depth so that the top of the pipe shall not be less than thirty-six (36) inches below the surface of the ground when laid through wooded areas, fields, and other such areas outside the pavement or traveled surface of highways and roadways. The minimum depth of cover shall not be less than forty-two (42) inches for pipelines laid in the shoulder or traveled surface of any highway and/or roadway. Extra depth of cover is required as shown on the profiles on the Plans. Should the contractor fail to follow the Plan Profile, the ENGINEER may require removal and replacement of the pipeline on the planned grade or installation of Air Release Valves and Pits, all without additional compensation.

All depths of cover are measured to the top of the pipe by placing a straight edge resting on the surface of the original ground and measuring down to the pipe away from the bell.

d. Location of Pipelines

The approximate location of the gravity sewers, sewage force main(s), and water lines in relation to the Limits of Rights-of-Way, pavement, *etc.*, is

shown on the Plans but not guaranteed. The location shown was chosen to minimize overall project cost with disturbance of greenery, pavement replacement, crushed stone for traffic bound roadway, *etc.*, considered. The final location as constructed may be varied by the contractor with the approval of the Engineer provided (1) the proposed location is within the permanent easement, (2) the proposed location is approved by the Owner or other agency or legal entity having jurisdiction, and (3) the effect does not increase the project cost. The final location in any event may be varied by necessity due to construction conditions at the direction of the Engineer due to requirements of the Tennessee Department of Transportation, the City of Dayton, Tennessee, Bledsoe County, or other agency or legal entity having jurisdiction.

e. Excavation Near Potable Water Lines

The contractor(s) shall protect proposed and existing water lines that cross sewer lines by providing 18-inch minimum separation between the proposed sewer line and the water line. When this vertical separation cannot be achieved, the water line shall be relocated to provide this separation or reconstructed with mechanical joint pipe with one full length of water pipe being centered over the sewer line so that both joints will be as far from the sewer line as possible.

When sewer lines are being laid parallel to existing water lines, there should be a minimum of ten (10) feet horizontal separation, or a minimum of eighteen (18) inches vertical separation as specified above, and the pipelines laid in separate trenches.

f. Excavation on Easements

Excavation of pipeline trenches on easements shall be performed in such a manner that the grounds shall be restored to as near their original condition as possible considering the work performed. The grass cover of the ditches or excavations shall be the same type as the original undisturbed cover.

Before any excavation is begun or before drilling and blasting, a minimum of nine (9) inches of the topsoil or the original cover shall be removed and stockpiled in a manner so as not to contaminate the topsoil with other fill or excavated material. Should the depth of excavation require a trench wider than specified in Sub-paragraph a. General hereinbefore, a minimum of nine (9) inches of topsoil or original cover shall be removed from the additional area and stockpiled as described hereinbefore.

Excavated materials suitable for backfill shall be placed at a distance far enough from the ditch to allow excavated rock to be placed next to the

open trench; however, stockpiling outside the easement shall be done only with the property owner's written permission. THE CONTRACTOR'S ATTENTION IS CALLED TO SECTION 1, PARAGRAPH 16 OF THESE DETAILED SPECIFICATIONS.

g. Removal of Water

The contractor shall at all times during construction provide and maintain means and devices with which to promptly dispose of all water entering the excavations or other parts of the work and shall keep said excavations dry until the structures to be built therein are completed. No concrete shall be placed in water nor shall water be allowed to rise over structures if there is danger of flotation or of setting up unequal pressures in the concrete, until the concrete has set at least 24 hours and any danger of flotation has been removed.

The Contractor shall dispose of water from the work in a suitable manner without damage to adjacent property or sewers. No water shall be drained into work built or under construction.

During the laying of lines and until the water pipe has been bedded in place with at least two (2) feet of backfill over the pipe, the contractor shall keep the groundwater table below the bottom of the trench.

No lines will be permitted to be laid except in a dry trench. Running water shall be completely blocked off by dewatering and/or sheathing. The trench must be dry and clean to assure that the hub and spigot of the pipe are perfectly dry before a joint is made.

All removal and handling of water required to maintain dry trenches or other excavations for the construction of lines or other structures in the dry trench shall be at the expense of the contractor.

7. Shoring, Sheet piling and Bracing of Excavations

It is the sole responsibility of the Contractor(s) to determine sheet piling, shoring and bracing of excavations and such work is NOT a separate pay item.

In some cases, a note on the Plans indicates shoring and sheet piling is required; where this occurs, the cost of same shall be merged into the cost of the pipeline (no extra payment).

8. Pipe Laying, Bedding and Protection – Water Lines

Water lines shall be laid on line and grade as shown on the Plans with extra depth where shown to facilitate the removal of air and/or to comply with the depth

requirements shown on the Plans and in Subparagraph 6.c. of this Section of these Detailed Specifications.

**Unless specifically approved in writing by the Engineer, not more than five (5,000) thousand L.F. of pipeline shall be laid without successful testing as specified under Paragraph 15. Hydrostatic Testing of Water Lines of this Section.**

The trench shall be excavated to the required depth and width, bell holes and/or jointing holes shall be dug in advance of pipe laying.

The bed of each piece of pipe shall be carefully prepared so that each individual piece of pipe shall have a uniform bearing. Pipes shall be laid in a straight line and grade without kinks or sags and shall be laid in a workmanlike manner. Bell holes and/or jointing holes shall be large enough so that the bell or hub will clear the ground and leave ample room for making joint and inspection of joints.

Before each piece of pipe is lowered into the trench, it shall be thoroughly swabbed out to ensure its being clean. Each piece of pipe shall be lowered separately unless special permission is given otherwise by the Engineer.

Care shall be taken to prevent injury to the pipe coating both inside and out. No piece of pipe or fitting which is known to be defective shall be laid or placed in the lines.

If any defective pipe or fitting shall be discovered after the pipeline is laid, they shall be removed and replaced with a satisfactory pipe or fitting without additional charge. In case a length of pipe is cut to fit a line, it shall be so cut as to leave a smooth end at right angles to the longitudinal axis of the pipe as per AWWA C600.

All angles or bends in the pipelines, either vertical or horizontal, shall be satisfactorily braced or anchored against the tendency of movement with joint harness, concrete or equal anchors to the satisfaction of the Engineer and as shown on the Plans.

Open ends of unfinished pipelines shall be securely plugged or closed at the end of each day's work or when the lines are left temporarily at any other time. The maximum horizontal or vertical deflection for laying pipe shall be 1<sup>o</sup> per pipe section unless the manufacturer's printed instructions permit a greater deflection.

9. Unauthorized Excavation and Over-Breakage

Whenever the excavation is carried beyond or below the lines and grades given by the Engineer, the contractor, at his own expense, shall refill such excavated space with such material and in such a manner as will ensure stability of the line involved, including the use of crushed stone or Class "C" concrete.



Over-breakage is that portion of any material displaced or loosened beyond the finished work as planned or authorized by the Engineer, including slides. All over-breakage shall be removed by the contractor and disposed of as directed. PAYMENT WILL NOT BE MADE FOR REMOVAL AND DISPOSAL OF OVER-BREAKAGE.

10. Crushed Stone for Pipe Bedding in Rock

When rock is encountered, the trench shall be excavated to a depth at least six (6) inches below the invert of the pipe and refilled with the bedding material to a sufficient depth to provide a firm bed for the bottom quadrant of the pipe. Crushed stone or shall be utilized to the depths as shown on the Plans.

Bedding shall be crushed stone meeting the requirements of the TDOT No. 67 gradation. The price of such material shall NOT be a separate pay item.

11. Highway Crossings

a. General

Where shown on the Plans, highway crossings for water lines shall be bored to prevent interruption to traffic and to prevent later settlement of the roadway or roadbed. City streets may be “open-cut” except where otherwise shown on the Plans. There the following Tennessee Department of Transportation requirements apply: “Where open cutting is allowed, the following conditions shall be met: (1) all backfill material shall be compacted crushed stone, (2) one-half of the traveled portion of the paving must be open at all times”. Crossings of the County roads will be open cut with permission of the Bledsoe County Highway Department.

The Contractor and his subcontractor must be fully equipped and experienced in the installation of pipelines by boring or tunneling methods. The Contractor shall be fully responsible for the successful operation without interruption of traffic and shall be held responsible for any settlement which occurs as a result of his work.

IT SHALL BE THE RESPONSIBILITY OF THE CONTRACTOR TO DETERMINE THE NUMBER OF BLOCKS AND SIZE REQUIRED (BORING) TO PREVENT FLOTATION OR NEGATIVE GRADE OF THE CARRIER PIPE. BLOCKING SHALL BE PRESSURE TREATED.

b. Bored Crossings

(1) General

Where shown on the Plans, crossing of railroads, U.S., State of Tennessee, City of Dayton or Bledsoe County Highways shall be made by boring with a steel casing pipe as specified in Subparagraph b.(2) hereinafter. The pipe shall be jacked through a bored hole. Where boring is required the holes shall be bored under the highway at least four (4) feet below the surface with no disturbance to the surface.

(2) Steel Casing Pipe

Black steel casing pipe shall be manufactured and tested in accordance with ASTM A139 or A 53, Grade B, 35,000 psi yield strength, and shall meet the American Railway Engineering Association (AREA) Specification for Metal Pipe and Arches, Chapter 1, Part 5. Steel casing pipe where shown shall be as follows:

<u>Diameter Carrier in inches</u>	<u>Diameter Casing in inches</u>	<u>Minimum Wall Thickness of Casing in inches</u>
4 or 6	12	0.25

12. Backfilling Pipeline Trenches

a. General

In the backfilling of the trench above the pipe or pipe envelope, material reasonably free from rock and acceptable to the Engineer shall be used; the backfill material shall be carefully and solidly tamped around the pipe up to the point where the pipe is thoroughly covered with at least one (1) foot of material.

In the backfilling of the trench outside of roadway rights-of-way, material reasonably free from rock and acceptable to the Engineer shall be used.

Walking or working on the completed pipeline, except as may be necessary in tamping or backfilling, shall not be permitted until the trench has been backfilled to a height of at least one (1) foot above the top of the pipe. The filling of the trench shall be carried on simultaneously on both sides of the pipe in such a manner that the completed pipeline will not be disturbed and injurious side pressures do not occur.

In filling the remainder of the trench, the backfill material may be shoveled into the trench without compacting, and heaped over whenever, in the opinion of the Engineer, this method of backfilling may be used without inconvenience to the public. Where street paving or shoulders are to be replaced, the contractor will be required to tamp or puddle all backfill as described hereinafter.

In areas where the line is laid in the right-of-way of a State Highway or when required by the Engineer, backfill shall be of select material of the same type as the existing natural material or fill in which the trench is dug. When so required by the Owner of the roadway, the backfill shall be placed in loose layers not exceeding six (6) inches and firmly tamped into place by tampers or rammers. The Engineer may also require puddling wherein, in his opinion, it is also necessary for proper compaction.

Whenever, in the opinion of the Engineer, it is necessary, he may require the contractor to use a combination of any or all of the above outlined methods for proper compaction of the backfill in the trenches.

Before final acceptance, the contractor will be required to level off all trenches where backfill material has been piled up, or to bring the trench up to the level of the surrounding street, roadway, or terrain. The contractor will be required to remove from the streets, roadways, and private property all excess earth or other materials.

b. Backfill in Paved Areas

(1) State Highways

Flowable fill meeting the requirements of Section 204.06 Backfill Material of the TDOT Standard Specification for Road and Bridge Construction shall be used for backfill of excavations in State Highways. The Contractor shall use flowable fill that can be excavated after final set (removable variety).

(2) City Streets, Alleyways, etc.

Crushed stone backfill meeting the quality requirements of ASTM D692 and the gradation requirements for size 57 or size 67, TDOT Specification Subsection 903.22 shall be used for all final backfill of excavations under existing or proposed paved areas.

c. Backfilling Operations Conducted on Easements

Backfilling of trenches or excavations on easements shall be performed in such a manner that the private property owner's facilities and grounds shall

be restored to as near as possible their original condition immediately after pipe laying.

After the pipe bedding, pipe, and backfill along the sides of the pipe and over the pipe (if required) as specified hereinbefore has been placed, the excavated rock next to the ditch shall be placed in the ditch. Excavated rock shall not be placed any closer than eighteen (18) inches from the finished grade and any excess rock shall be removed by the contractor and disposed of as directed.

The residue of the stockpiled bedding material shall be cleaned up and placed into the trench, leaving no bedding stone scattered over the area. The previously excavated materials suitable for backfill shall be placed into the ditch only upon clean-up and backfill of the bedding material. The top portion of the trench or excavation shall be filled using the stockpiled topsoil. The ditch shall be left high to allow for settling unless in the opinion of the Engineer this method of backfilling will cause inconvenience to the private property owner. Seeding or sodding shall proceed immediately following backfill.

If the backfilling operation is performed during extremely dry weather the contractor should leave some stockpiled topsoil to use later as additional fill after settlement has occurred.

THE CONTRACTOR(S) WILL BE HELD RESPONSIBLE FOR THE CONDITION OF GRASS COVER AND THE CONDITION OF THE GROUND SURFACE AT THE TIME OF FINAL INSPECTION UNLESS THE PRIVATE OWNER HAS PLOWED OR EXCAVATED THE GROUND.

d. Disposal of Excess Material

The contractor shall be responsible for the off-site disposal of any and all excess or unsuitable material excavated in the construction of the project. He shall be responsible for obtaining any and all permits, license fees, *etc.*, associated with the disposal of excess material.

13. Pipeline Trenches Within Existing Roadways

Where excavation is within the traveled portion of State Highways or Bledsoe County roads, all native earth and rock shall be removed and hauled away and disposed of by the Contractor(s) at his own expense. The resulting backfill material shall be as specified in Paragraph 12.b.

14. Inspection of Lines - During Construction

The contractor shall notify the Engineer when pipe will be received on the job so that proper arrangements may be made for inspecting the unloading and stringing, as well as inspecting the pipe proper and examining for the stamp of the independent laboratory, if applicable.

BEFORE THE CONTRACTOR BACKFILLS ANY OF THE LINES, THEY SHALL BE FIRST INSPECTED BY THE ENGINEER; AND THE ENGINEER SHALL GIVE THE CONTRACTOR PERMISSION TO PROCEED WITH THE BACKFILLING. If any joints, pipes, or other workmanship or materials are found to be defective, they shall be removed and replaced by the contractor without any extra compensation.

15. Hydrostatic Testing of Water Lines

Testing of lines shall comply with the provisions listed below, or similar approved procedures which will ensure equal or better results.

Pipelines of whatever material, when tested under a pressure of 1.25 times the normal working pressure of the pipe as shown on the Plans, measured at the **lowest** elevation of the pipe shall not show leakage exceeding the following values as prescribed by the latest revision of AWWA C600.

<u>Pipe Size &amp; Type</u>	<u>Test Pressure</u>	<u>Allowable Leakage / 1,000 feet (gallons per hour)</u>
2-inch W.L.	100 psi	0.14
4-inch W.L.	100 psi	0.27
6-inch W.L.	100 psi	0.41

The Contractor(s) shall furnish all gauges, meters, pumps, and other equipment required and shall maintain said equipment in condition for accurate testing as determined by the Engineer. Where leaks are visible at exposed joints and/or evident on the surface when joints are covered, the pipe shall be rejoined, and leakage minimized regardless of total leakage as shown by test.

Duration of test shall be not less than two (2) hours where joints are exposed and not less than 8 hours where joints are covered. Lines which fail to meet the leakage requirements shall be repaired and retested until test requirements are met. All pipe, fittings, and other materials found to be defective under test shall be removed and replaced at the contractor's expense.

Pipelines shall be held under normal operating pressures for at least three (3) days before testing.

16. Disinfection of Lines

Water lines shall be disinfected as required by ANSI/AWWA C651 as amended and expanded herein. The new water lines shall not be placed in service--either temporarily or permanently--until they have been thoroughly disinfected in accordance with the following requirements and to the satisfaction of the Engineer.

After testing, a solution of hypochlorite using HTH or equal shall be introduced into the section of the lines being disinfected sufficient to insure a chlorine dosage of at least 50 ppm in the lines. While the solution is being applied, the water shall be allowed to escape at the ends of the lines until tests indicate that a dosage of at least 50 ppm has been obtained throughout the pipe.

The chlorinated water shall be allowed to remain in the pipe for 24 hours. A residual of at least 25 ppm should be present in the pipe at the end of a 24-hour period. After the chlorinated water has remained in the line for 24 hours, the line will be flushed and refilled and a bacteriological sample will be taken by the Owner. If a negative sample is obtained, the line shall be thoroughly flushed and then may be connected to the system. If a positive sample is obtained, the disinfection procedure must be repeated until a negative sample is obtained. The cost of the bacteriological test will be borne by the Owner. Disinfection is NOT a pay item. The Owner will pay for the water required for the initial filling of the lines and for the first refill of water for flushing, but the Contractor shall pay for any other water required.

17. Gate Valves and Boxes

Gate valves shall conform to AWWA C509, latest revision, as modified herein. All gate valves shall be of the resilient seated type, iron body, non-rising stem, suitable for water working pressure of 250 psi. Valves shall be of a standard manufacture and of the highest quality both as to materials and workmanship. An affidavit of compliance is required. Bolting materials shall be cadmium plated. The stem sealing shall be by an O-ring.

All gate valves shall be furnished with mechanical joint end-connections, unless otherwise shown on the Plans or specified herein. The end-connections furnished shall be suitable for connection to the pipe furnished.

All gate valves shall have the name or monogram of the manufacturer, the year the valve casting was made, the size of the valve, and the working water pressure cast on the body of the valve. They shall be coated with black asphalt varnish and touched up in the field as required.

All gate valves shall be provided with a 2-inch square operating nut and shall open as shown on the Plans. Resilient seats shall apply to both sides of the gate. Gate valves shall be M & H, American Flow Control, Clow, or an approved equal.

Valve boxes shall be cast iron, THREE (3) PIECE, screw type with drop cover identifying the valve as "Water". They shall be set vertically and properly adjusted so that the cover shall be in the same plane as the finished surface of the ground or street.

For ease of location and identification outside of paved areas, a 2'-0" square by 6-inch-thick concrete pad with a cast aluminum plaque imbedded therein shall be furnished as shown on the Plans. The plaque shall show the valve size and type.

18. Rip-Rap

Where shown on the Plans or directed by the Engineer, rip-rap shall be of the rubble-stone type (Plain) and hand placed to a depth of not less than twelve (12) inches. Materials and construction methods for rubble stone rip-rap (Plain) shall conform to the requirements of Section 709 of the Tennessee Department of Transportation Standard Specifications.

19. Rock Excavation

ROCK EXCAVATION IS NOT A SEPARATE PAY ITEM.

20. Pipe Laying and Bedding for Water Lines

a. General

The trench shall be excavated to the required depth and width; bell holes and/or jointing holes shall be dug in advance of pipe laying.

The bed of each piece of pipe shall be carefully prepared so that each individual piece of pipe shall have a uniform bearing. Pipes shall be laid in a straight line and grade without kinks or sags and shall be laid in a workmanlike manner. Bell holes and/or jointing holes shall be large enough so that the bell or hub will clear the ground and leave ample room for making joint and inspection of joints.

Before each piece of pipe is lowered into the trench, it shall be thoroughly swabbed out to ensure its being clean. Each piece of pipe shall be lowered separately unless special permission is given otherwise by the Engineer.

Care shall be taken to prevent injury to the pipe coating both inside and out. No piece of pipe or fitting which is known to be defective shall be laid or placed in the lines.

If any defective pipe or fitting shall be discovered after the pipeline is laid, they shall be removed and replaced with a satisfactory pipe or fitting without additional charge. In case a length of pipe is cut to fit a line, it shall be so cut as to leave a smooth end at right angles to the longitudinal axis of the pipe as required by AWWA C600.

All angles or bends in the pipelines, either vertical or horizontal, shall be satisfactorily braced or anchored against the tendency of movement with joint harness, concrete or equal anchors to the satisfaction of the Engineer and as shown on the Plans.

Open ends of unfinished pipelines shall be securely plugged or closed at the end of each day's work or when the line is left temporarily at any other time. The maximum horizontal or vertical deflection for laying pipe shall be one-half the allowable manufacturer's deflection.

b. Unstable Trench Bottom Material or Undercutting

If wet, mucky and/or unstable or unsuitable material is encountered in the trench bottom, it shall be excavated and backfilled as specified in Paragraph 6.b. Unstable Trench Bottom Material or Undercutting, hereinbefore.

The Engineer shall determine when it is necessary to use such material and the Contractor shall be responsible for calling such unstable trench bottom conditions to the attention of the Engineer.

21. Replacing Streets and Roadways

a. General

The Contractor(s) shall replace all streets, alleys and roadways which may be removed, disturbed, or damaged in connection with his operation under this Contract. The Contractor(s) shall reconstruct same to the original lines and grades and in such manner as to leave all such surfaces in fully as good or better condition as that which existed prior to his operations. The reuse of materials removed in making excavations will be permitted provided said materials will properly compact.

Gravel, crushed limestone, bituminous materials, or other materials used in the resurfacing of streets shall meet the current requirements of Bledsoe County or the Tennessee Department of Transportation.

ANY DISTURBANCE BEYOND THE MAXIMUM ALLOWABLE WIDTH OF FIVE (5) FEET FOR PAY ITEMS WILL BE CONSIDERED



CONTRACTOR'S NEGLIGENCE AND SHALL BE REPAIRED AND/OR REPLACED AT THE CONTRACTOR'S EXPENSE.

At least one-half of the traveled portion of any open cut roadways must be open to traffic at all times. Further, the Contractor(s) shall maintain traffic in at least one (1) lane at all times. No gravel trenches shall be open to traffic at any time. The Contractor(s) shall coordinate all work in traveled roadways with the Tennessee Department of Transportation, the Bledsoe County Highway Department, police and fire departments. The Contractor(s) shall furnish all warning signs, barricades, channelization devices, *etc.*, which may be required. The Contractor(s) will provide these services. All traffic control devices shall be in accordance with the manual of uniform traffic control devices, current revision. The Contractor(s) is solely responsible for job safety and he shall hold the Engineer and the Owner harmless from any claims arising thereof.

b. Backfill of Trenches Under Roadways

Replacement of streets and roadways after trenching shall be handled in the following manner:

When stone is used to backfill the trench, it shall be brought to finished grade. Where excavation is within the traveled portion of State Highways or County streets, all native earth and rock shall be removed and hauled away and disposed of by the Contractor(s) at his own expense. The resulting backfill material shall be compacted TDOT No. 67 Crushed Stone as shown on the Plans.

c. Traffic-Bound Base Course

The Contractor(s) shall maintain the traffic-bound base course by adding crushed stone as specified above in a safe and passable condition for a period of sixty (60) days if dust control is provided, or until such time as sufficient settlement has taken place so that a base exists at least six (6) inches thick; and trenches are ready for final resurfacing. Crusher Run stone added to ditches for maintenance after initial backfill will not be cause for additional payment. Crushed stone will be paid for at the unit price specified in the BID FORM.

d. Subgrade for Final Resurfacing

The traffic-bound course described above shall comprise the base course for all types of resurfacing.

When in the opinion of the Engineer, the trench has reached a condition of settlement satisfactory for final resurfacing, the Contractor(s) shall first

strip the base course or backfill of crushed stone (size as specified above) to obtain the proper subgrade elevation. The subgrade shall then be rolled with an approved type roller or tamped until thoroughly compact and six (6) inches thick.

Any depressions shall be filled with crushed stone or gravel (as specified) and the process of rolling or tamping continued until the subgrade has a smooth and uniform surface.

e. Binder Course

A minimum of three (3) inches of compacted Grade "B" Modified (B-M) binder as specified in the Tennessee Department of Transportation Special Provision Section 307 shall be required in all trenches within the traveled surface of all Bledsoe County streets as shown on the plans.

f. Asphaltic Concrete Pavement (Hot Mix)

Where asphaltic concrete pavement is to be replaced, the subgrade shall be prepared as specified hereinbefore, and this subgrade shall comprise the base course upon which the asphaltic pavement shall be laid. The existing pavement shall be neatly cut back approximately one (1) foot outside the trench and the new pavement tied into the existing.

The subgrade or base shall be thoroughly cleaned and broomed and a prime coat of medium tar shall be uniformly applied at a rate of 0.20 to 0.25 gallons per square yard.

Where Portland cement concrete subslab is required, the prime shall be applied to the concrete at a rate of 0.05 gallons per square yard. The prime shall be applied by a pressure distributor or other approved pressure spray method.

When the prime coat has become tacky, but not dry and hard, the asphaltic concrete shall be placed, spread, finished and compacted in accordance with the current standard specifications of the Tennessee Department of Transportation, Section 411, Grading E, with eighty-five (85) to one hundred (100) penetration grade asphalt. Compacted thickness of asphaltic concrete pavement replacement shall be a minimum of two (2) inches as shown on the Plans.

22. Class "C" Concrete for Kickers, Anchors and Encasements

Concrete used for anchors, kickers, and encasement shall be Class "C" concrete as called for on the Plans and Specifications.

23. Final Clean-up

Before the work is considered as complete, all rubbish and unused material due to or connected with the construction shall be removed and the premises left in a condition satisfactory to the Engineer. Final acceptance will be withheld until such work is completed.

Seeding for water lines is not a separate pay item. The Contractor shall clean-up and provide seeding, sodding, and landscaping as the pipe installation progresses. The Owner will reject payment of pipe quantities installed for which greater than 2,000 linear feet of cleanup and seeding, sodding and landscaping remain.

\*\*\*\*\*

## SECTION 5

### BASIS OF PAYMENT

#### 1. General

The Contractor(s) shall furnish all necessary labor, equipment, materials, machinery, tools, apparatus, services and supplies required to perform all work set forth in this Section of these Detailed Specifications at the lump sum or unit prices for the items listed in this Section.

ROCK EXCAVATION, SHEETING, SHORING AND BRACING OF EXCAVATIONS AND BEDDING AS SHOWN ON THE PLANS ARE NOT SEPARATE PAY ITEMS.

These items refer to and are the same items listed in the BID FORM and constitute all of the pay items. Any other items of work listed in these Detailed Specifications or shown on the Plans shall be considered incidental to the following items.

#### 2. Connections to Existing Facilities

Unless shown as a pay item in the BID FORM, all connections to existing facilities and cutting and capping of existing water lines are considered incidental to work and the cost of same shall be included in the appropriate pay items. Lump Sum Connections listed in the BID FORM including excavation, backfilling and backfill, crushed stone, asphaltic concrete pavement, furnishing and installing all fittings, valves, pipe, concrete pads and appurtenances and kickers of the sizes and type shown on the Plans will be made at the Lump Sum Contract price as shown in the BID FORM complete in place.

#### 3. Water Line

Payment will be made at the Contract unit prices shown in the BID FORM per linear foot for each size and material listed, complete in place, at the depth shown on the Plans, including pipe, fittings, restrained joints, trenching, jointing, bedding, removal of water and all incidentals thereto, also including backfilling, *etc.* The quantity to be paid for shall be the length of the pipe measured along the centerline, without deducting for fittings.

#### 4. Restrained Joint Pipe

Restrained joint pipe where shown on the Plans or directed by the Engineer will be paid for at the contract unit price per linear foot as shown in the BID FORM. Restraint against flotation is not a separate pay item.

5. Steel Casing Pipe

Payment for installing by boring Steel Casing Pipe of the sizes shown in the BID FORM as a carrier for water lines will be made at the contract unit price per linear foot as shown in the BID FORM.

6. PVC Casing Pipe for Service Lines

Payment for installing by open-cut PVC Casing Pipe for service line of the sizes shown in the BID FORM as a carrier for service lines will be made at the contract unit price per linear foot as shown in the BID FORM.

7. Gate Valve Assemblies

Payment for furnishing and installing resilient seat gate valves and boxes including concrete pad and setting a cast aluminum plaque of the sizes shown in the BID FORM in the water lines will be made at the contract unit price each, complete in place.

8. Air Release Valves

Payment for furnishing and installing air release valves of the sizes shown and boxes will be made at the contract unit price each, complete in place as specified and the sizes shown in the BID FORM.

9. 3/4-Inch Service Connections

Payment for tapping the main, excavation, and installing all required fittings and meter box will be paid for at the contract unit price each shown in the BID FORM, complete in place. Service connection pipe will be paid for under another item.

10. Service Line Installation – 3/4-Inch Type K Copper Service Lines

Payment for installing 3/4-inch service lines by open-cut or boring between the water main and the meter box as shown on the BID FORM will be paid for at the contract unit price per linear foot, complete in place, including all incidentals.

11. Class "C" Concrete for Kickers, Anchors, and Encasement

Class "C" concrete for kickers and anchors or encasement where directed by the Engineer will be paid for at the Contract unit price per cubic yard shown in the BID FORM, complete in place. The cost of any necessary bolts, strips or other metal fittings shall be included in the price of the concrete.

12. Flowable Fill Backfill

Flowable fill backfill will be paid for at the Contract price per cubic yard shown in the BID FORM, complete in place. The cost of excavation and all incidentals shall be included in the price of the flowable fill. ANY ADDITIONAL WIDTH WILL BE CONSIDERED OVER-BREAKAGE WHICH SHALL BE BACKFILLED AT THE CONTRACTOR'S EXPENSE.

ANY DISTURBANCE BEYOND THE MAXIMUM ALLOWABLE WIDTH WILL BE CONSIDERED CONTRACTOR'S NEGLIGENCE AND SHALL BE REPAIRED AND/OR REPLACED AT THE CONTRACTOR'S EXPENSE. THE MAXIMUM ALLOWABLE WIDTH IS TEN (10) FEET UNLESS OTHERWISE SHOWN ON THE PLANS.

13. Undercutting of Trench and Stone for Undercutting

Where undercutting and stone refill of the trench is directed by the Engineer, the crushed stone used to bring the trench back to grade will be paid for at the Contract unit price per cubic yard as shown in the BID FORM. The quantity will be computed from a plane 6 inches below the invert of the pipe to the bottom of the ordered extra excavation using the actual ditch width but not exceeding the maximum width allowed by these Detailed Specifications. Excavation of undercutting is NOT a separate pay item. The Contractor(s) will furnish the Engineer a duplicate weigh slip for all such undercutting material delivered to the job for records as a check on computations.

14. Crushed Stone for Traffic Bound Surfacing, Base Course, and Backfill

Crushed stone as shown on the Plans or specified hereinbefore will be paid for at the Contract unit price per theoretical cubic yard of material furnished and placed, and mechanically tamped in 6-inch layers, as shown in the BID FORM. The theoretical quantity will be computed using either the actual width or the maximum specified width, whichever is smaller. ANY ADDITIONAL WIDTH WILL BE CONSIDERED OVER-BREAKAGE WHICH SHALL BE BACKFILLED AT THE CONTRACTOR'S EXPENSE.

15. Asphaltic Concrete Pavement

Asphaltic concrete pavement will be paid for at the Contract unit price per cubic yard shown in the BID FORM, complete in place, including primer. The Contractor(s) shall replace all other damaged pavement at his own expense.

ANY DISTURBANCE BEYOND THE MAXIMUM ALLOWABLE WIDTH WILL BE CONSIDERED CONTRACTOR'S NEGLIGENCE AND SHALL BE REPAIRED AND/OR REPLACED AT THE CONTRACTOR'S EXPENSE. THE MAXIMUM ALLOWABLE WIDTH SHALL BE AS SHOWN ON THE PLANS.

16. Temporary Silt Fence

Temporary silt fence with hay or straw bales installed as shown on the Plans or as directed by the Engineer will be paid for, complete in place, at the contract unit price shown in the BID FORM per linear foot, including removal of the temporary silt fence and hay or straw bales within the one-year warranty period and at the direction of the Engineer.

17. Rip-Rap

Rip-rap, hand placed, where shown on the Plans or directed by the Engineer, shall be paid for at the contract unit price per square yard, complete in place as shown in the BID FORM.

\*\*\*\*\*

# WATER SYSTEM IMPROVEMENTS

FOR THE CITY OF

# DAYTON, TENNESSEE

## CONTRACT 23-01

SUMMER CITY ROAD WATER RELOCATION  
FUNDED BY ARPA GRANT NO. 2022-7863-DW-PDC-01

PROJECT NO. 4657

MARCH, 2024

# WAUFORD

Maryville, Tennessee  
(865)984-9638  
www.jrwauford.com



ENVIRONMENTAL



## INDEX OF DRAWINGS

SHEET	DESCRIPTION
1.	KEY MAP, GENERAL NOTES, AND LEGEND
2.	LINE "W-1" - STA. 0+00 TO E.O.L. LINE "W-2" - STA. 0+00 TO E.O.L. LINE "W-3" - STA. 0+00 TO E.O.L.
3.	LINE "W-4" - STA. 0+00 TO E.O.L.
4.	LINE "W-5" - STA. 0+00 TO E.O.L.
5.	SELECT WATER LINE AND SERVICE LINE PROFILES
6.	DETAIL SHEET

## CITY OFFICIALS

**MAYOR**

HURLEY MARSH

**VICE MAYOR**

STEVE E. RANDOLPH

**COUNCILMEN**

BOBBY J. DOSS

WILLIAM C. "BILLY" GRAHAM

CALEB YAWN

**CITY MANAGER**

DAVID SHINN

**SUPERINTENDENT OF  
WATER DEPARTMENT**

MARTY MORGAN

**CITY ATTORNEY**

SUSAN E. ARNOLD

APPROVED: 

DAVID SHINN, CITY MANAGER



**KEY MAP LEGEND**

- EXISTING WATER LINE
- PROPOSED WATER LINE
- TANK
- BOOSTER STATION
- ⊗ CLOSED VALVE

**LEGEND FOR PLAN SHEETS**

- PROPOSED
- WATER LINE
  - ⊗ GATE VALVE ASSEMBLY
  - ⊗ WATER METER TO BE RELOCATED
  - ⊗ AIR RELEASE VALVE
  - ▶ KICKER
  - ▶ PLUG
  - XXXXXX TO BE RETIRED IN PLACE



Know what's below.  
Call before you dig.

**GENERAL NOTES:**

1. ALL PROPOSED WATER LINES SHALL BE PRESSURE TESTED AND DISINFECTED PRIOR TO PLACING INTO SERVICE OR RECONNECTING EXISTING SERVICES.
2. THE CONTRACTOR SHALL BE SOLELY AND STRICTLY LIABLE FOR ANY VIOLATIONS OF STATE OR FEDERAL WATER POLLUTION LAWS, REGULATIONS OR STANDARDS CAUSED DURING CONSTRUCTION BY THE CONTRACTOR'S FORCES OR SUBCONTRACTORS AND SHALL PAY ANY PENALTIES LEVIED BY ANY AGENCY DUE TO SAID VIOLATIONS.
3. THE CONTRACTOR SHALL STAY WITHIN THE LIMITS OF CONSTRUCTION.
4. THE LOCATION AND DEPTH OF ALL EXISTING UNDERGROUND UTILITIES SHALL BE FIELD VERIFIED PRIOR TO THE CONTRACTOR COMMENCING CONSTRUCTION. THE CONTRACTOR SHALL NOTIFY THE ENGINEER OF ANY REQUIRED MODIFICATIONS IMMEDIATELY.
5. THE CONTRACTOR SHALL BE RESPONSIBLE FOR THE REPAIR AND/OR REPLACEMENT OF ALL EXISTING DRAINAGE CULVERTS DISTURBED DURING CONSTRUCTION. NO ADDITIONAL PAYMENT WILL BE MADE FOR THIS WORK.
6. THE NAMES OF PROPERTY OWNERS, PROPERTY LINES, STREET AND ROAD RIGHTS-OF-WAY SHOWN ON THESE PLANS WERE OBTAINED FROM BLEDSOE COUNTY TAX MAP AND THE BLEDSOE COUNTY TAX ASSESSOR. THIS INFORMATION IS ONLY GENERAL IN NATURE AND IS NOT GUARANTEED BY THE ENGINEER.
7. THE PROJECT SURVEY WAS PROVIDED AS PART OF A TENNESSEE DEPARTMENT OF TRANSPORTATION HIGHWAY PROJECT AND IS NOT GUARANTEED.

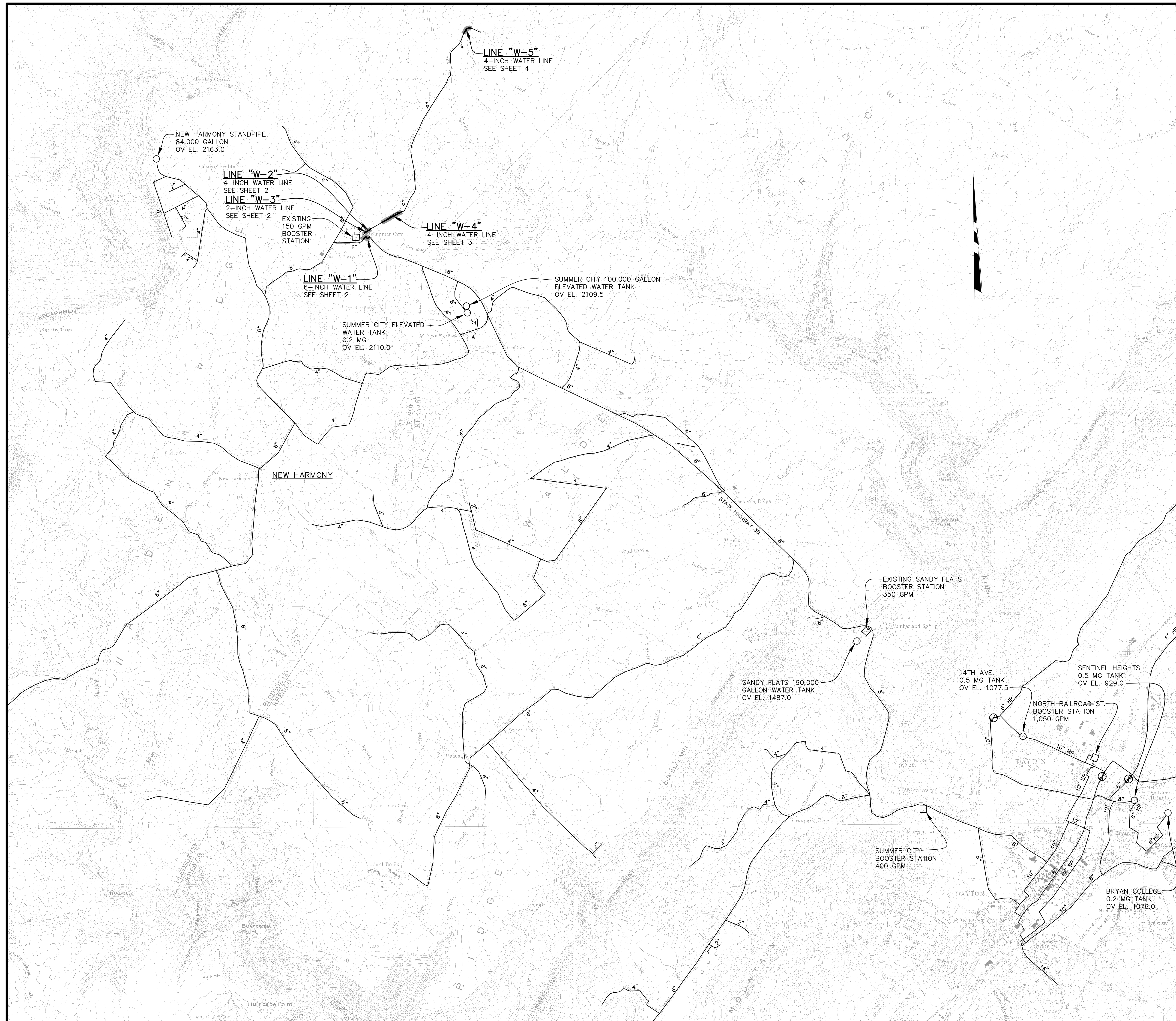

SHEET <b>1</b> OF <b>6</b>		<b>WATER SYSTEM IMPROVEMENTS</b> CONTRACT 23-01 SUMMER CITY ROAD WATER RELOCATION	
REVISION OR ISSUE		<b>KEY MAP, GENERAL NOTES, AND LEGEND</b>	
FOR		DAYTON, TENNESSEE	
SCALE	1"=2000'	DESIGNED	DGT
PROJECT NUMBER	4657	DRAWN	RSS
DATE	MAR. 2024	CHECKED	JGD
		<b>WAUFORD</b> Maryville, Tennessee (865)984-9638 www.jrwauford.com	



POINT	NORTH	EAST	ELEVATION	FEATURE	DESCRIPTION	STATION	OFFSET
S05	453288.4435	2231244.8974	1967.3250	XCP	GPS 04-30-05	20+03.62	-27.5612
S06	452895.5017	2231369.0789	1968.1080	XCP	GPS 04-30-06	24+18.67	22.9032

CP-S05	N 453288.4434 E 2231244.8973 EL. 1967.3253 *04-30-05*	WITNESS POST YELLOW POLE NEXT TO STORAGE UNIT #77 N&C IN EDGE OF PAVEMENT
CP-S06	N 452895.5018 E 2231369.0789 EL. 1968.1083 *04-30-06*	N&C IN EDGE OF PAVEMENT MM 18 WITNESS POST

BEGINNING AT THE RHEA/BLED SOE COUNTY LINE ON SR-30 SE OF PIKEVILLE, GO WEST ON SR-30 0.66 MILES TO 04-30-05. STATION IN ON THE RIGHT.

BEGINNING AT THE RHEA/BLED SOE COUNTY LINE ON SR-30 SE OF PIKEVILLE, GO WEST ON SR-30 0.58 MILES TO 04-30-06. STATION IS ON THE LEFT.

**\*\* NOTE \*\***  
 ITEMS LISTED BELOW SHALL NOT BE DISTURBED DURING CONSTRUCTION. ANY DAMAGES OCCURRING TO THESE ITEMS DUE TO CONSTRUCTION ACTIVITIES SHALL BE REPAIRED BY THE CONTRACTOR AT THE CONTRACTOR'S EXPENSE.

TRACT NO. 2 - MEXICAN FOOD SIGN AND SIGN BASE RT STA. 22+32.  
 TRACT NO. 3 - EXISTING VACUUM MACHINES & PLATFORMS LT STA'S. 22+13 & 22+43

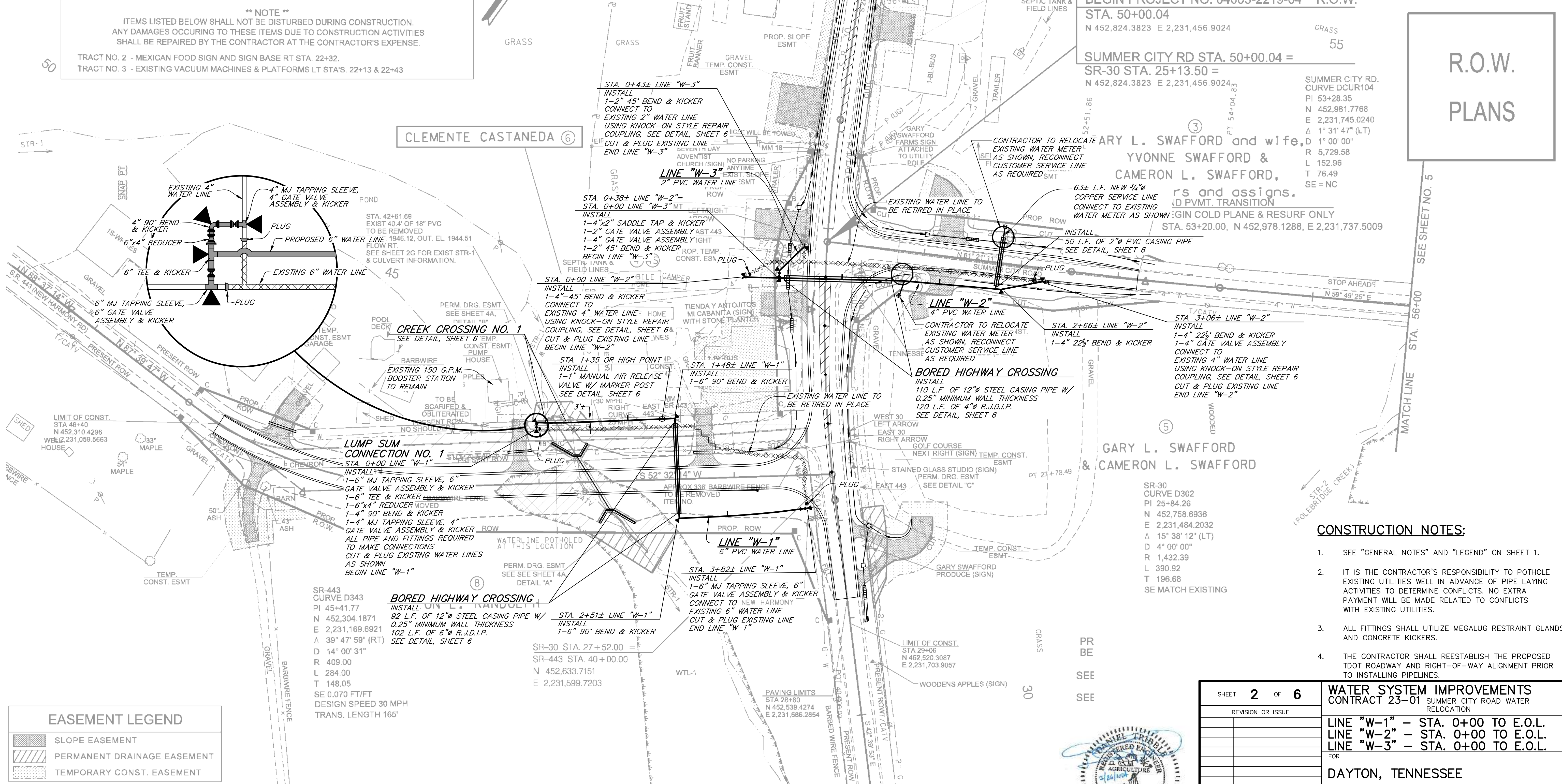

**BEGIN PROJECT NO. 04003-3219-04 CONST.**  
 STA. 50+00.04  
 N 452,824.3823 E 2,231,456.9024

**BEGIN PROJECT NO. 04003-2219-04 R.O.W.**  
 STA. 50+00.04  
 N 452,824.3823 E 2,231,456.9024

**SUMMER CITY RD STA. 50+00.04 = SR-30 STA. 25+13.50 =**  
 N 452,824.3823 E 2,231,456.9024

**R.O.W. PLANS**

SUMMER CITY RD. CURVE DCUR104  
 PI 53+28.35  
 N 452,981.7768  
 E 2,231,745.0240  
 Δ 1° 31' 47" (LT)  
 R 1° 00' 00"  
 R 5,729.58  
 L 152.96  
 T 76.49  
 SE = NC

**GARY L. SWAFFORD & CAMERON L. SWAFFORD**

CONTRACTOR TO RELOCATE GARY L. SWAFFORD and wife, YVONNE SWAFFORD & CAMERON L. SWAFFORD, and assigns. ID PVMT. TRANSITION SIGN GOLD PLANE & RESURF ONLY  
 STA. 53+20.00, N 452,978.1288, E 2,231,737.5009

**GARY L. SWAFFORD & CAMERON L. SWAFFORD**

SR-30 CURVE D302  
 PI 25+84.26  
 N 452,758.6936  
 E 2,231,484.2032  
 Δ 15° 38' 12" (LT)  
 D 4° 00' 00"  
 R 1,432.39  
 L 390.92  
 T 196.68  
 SE MATCH EXISTING



SHEET 2 OF 6		WATER SYSTEM IMPROVEMENTS CONTRACT 23-01 SUMMER CITY ROAD WATER RELOCATION	
REVISION OR ISSUE		LINE "W-1" - STA. 0+00 TO E.O.L.	DESIGNED DGT
		LINE "W-2" - STA. 0+00 TO E.O.L.	DRAWN RSS
		LINE "W-3" - STA. 0+00 TO E.O.L.	CHECKED JGD
		FOR DAYTON, TENNESSEE	
SCALE	1"=50'	PROJECT NUMBER	4657
DATE	MAR. 2024	DESIGNED	DGT
		DRAWN	RSS
		CHECKED	JGD



# R.O.W. PLANS

③  
**GARY L. SWAFFORD and wife,  
 YVONNE SWAFFORD &  
 CAMERON L. SWAFFORD,**  
 their heirs and assigns.

REVISION- ROW 6-15-22: CORRECTED SYMBOLOGY OF TEMP CONST ESMT. ADDED EXISTING FIELD ENTRANCE RT STA 67+70. ADDED WWC-1A/EPH-1A RT STA 68+34. UPDATED EXISTING 18" HDP CROSS-DRAIN AT STA 88+36 AND ADDED EXISTING RIP-RAP DITCH AT INLET AND OUTLET. ADDED PROP. FIELD ENTRANCE RT STA 67+65 AND ADJUSTED PROP. TEMP CONST ESMT. ADDED "PER BRIDGE RECOMMENDATIONS 9-3-2020" TO EXISTING BRIDGE INFO.  
 REVISION- ROW 10-26-22: ADDED NOTE "CONTRACTOR SHALL NOT DISTURB EXISTING TELAMON CORP. SIGN LT STA 64+50 AND CHAIN LINK FENCE ON TRACT 3. LT STA. 64+50."  
 REVISION- ROW 12-13-22: ADDED IMPACT INFORMATION FOR WWC-1a / EPH-1a.  
 REVISION- ROW 2-15-23: CHANGED TRACT NO. 3 OWNER'S NAME.

SUMMER CITY RD. CURVE DCUR107  
 PI 69+06.20  
 N 453.770.6831  
 E 2,235,109.1630  
 Δ 24° 40' 48" (LT)  
 D 24° 00' 00"  
 R 238.73  
 L 102.83  
 T 52.23  
 SE 0.080 FT/FT  
 DESIGN SPEED 30 MPH  
 TRANS. LENGTH 180'  
 (MATCH EXISTING SE AT 88+35)

KRISTY MARIE SWAFFORD

CHRIS NEAL

JOSHUA L. HANCOCK

TONYA STEPHENS

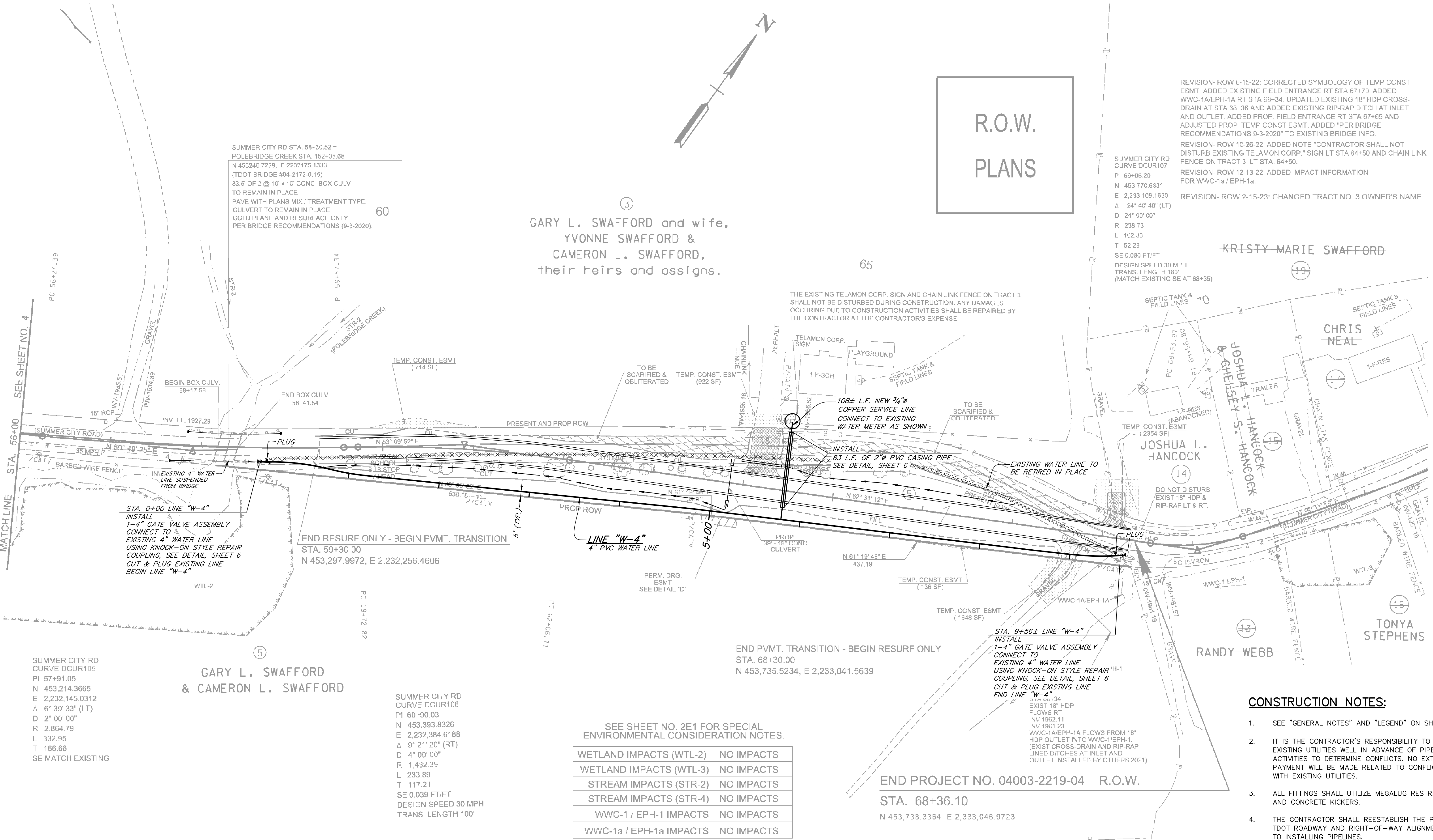

SUMMER CITY RD CURVE DCUR105  
 PI 57+91.05  
 N 453,214.3665  
 E 2,232,145.0312  
 Δ 6° 39' 33" (LT)  
 D 2° 00' 00"  
 R 2,864.79  
 L 332.95  
 T 166.66  
 SE MATCH EXISTING

⑤  
**GARY L. SWAFFORD  
 & CAMERON L. SWAFFORD**

SUMMER CITY RD CURVE DCUR106  
 PI 60+90.03  
 N 453,393.8326  
 E 2,232,384.6188  
 Δ 9° 21' 20" (RT)  
 D 4° 00' 00"  
 R 1,432.39  
 L 233.89  
 T 117.21  
 SE 0.039 FT/FT  
 DESIGN SPEED 30 MPH  
 TRANS. LENGTH 100'

SEE SHEET NO. 2E1 FOR SPECIAL ENVIRONMENTAL CONSIDERATION NOTES.

WETLAND IMPACTS (WTL-2)	NO IMPACTS
WETLAND IMPACTS (WTL-3)	NO IMPACTS
STREAM IMPACTS (STR-2)	NO IMPACTS
STREAM IMPACTS (STR-4)	NO IMPACTS
WWC-1 / EPH-1 IMPACTS	NO IMPACTS
WWC-1a / EPH-1a IMPACTS	NO IMPACTS

END PROJECT NO. 04003-2219-04 R.O.W.  
 STA. 68+36.10  
 N 453,738.3364 E 2,333,046.9723

### CONSTRUCTION NOTES:

- SEE "GENERAL NOTES" AND "LEGEND" ON SHEET 1.
- IT IS THE CONTRACTOR'S RESPONSIBILITY TO POTHOLE EXISTING UTILITIES WELL IN ADVANCE OF PIPE LAYING ACTIVITIES TO DETERMINE CONFLICTS. NO EXTRA PAYMENT WILL BE MADE RELATED TO CONFLICTS WITH EXISTING UTILITIES.
- ALL FITTINGS SHALL UTILIZE MEGALUG RESTRAINT GLANDS AND CONCRETE KICKERS.
- THE CONTRACTOR SHALL REESTABLISH THE PROPOSED TDOT ROADWAY AND RIGHT-OF-WAY ALIGNMENT PRIOR TO INSTALLING PIPELINES.



SHEET <b>3</b> OF <b>6</b>	<b>WATER SYSTEM IMPROVEMENTS</b> CONTRACT 23-01 SUMMER CITY ROAD WATER RELOCATION	
REVISION OR ISSUE	<b>LINE "W-4" - STA. 0+00 TO E.O.L.</b>	
FOR	DAYTON, TENNESSEE	
SCALE	1"=50'	DESIGNED DGT
PROJECT NUMBER	4657	DRAWN RSS
DATE	MAR. 2024	CHECKED JGD
		<b>WAUFORD</b> Maryville, Tennessee (865)984-9638 www.jrwauford.com



POINT	NORTH	EAST	ELEVATION	FEATURE	DESCRIPTION	STATION	OFFSET
S07	462176.9707	2236033.7874	2007.2780	XC <sup>3</sup>	GPS 04-30-07	80+61.95	18.5727
S08	462517.6645	2236138.3187	2012.3990	XC <sup>2</sup>	GPS 04-30-08	OFF CHAIN	OFF CHAIN

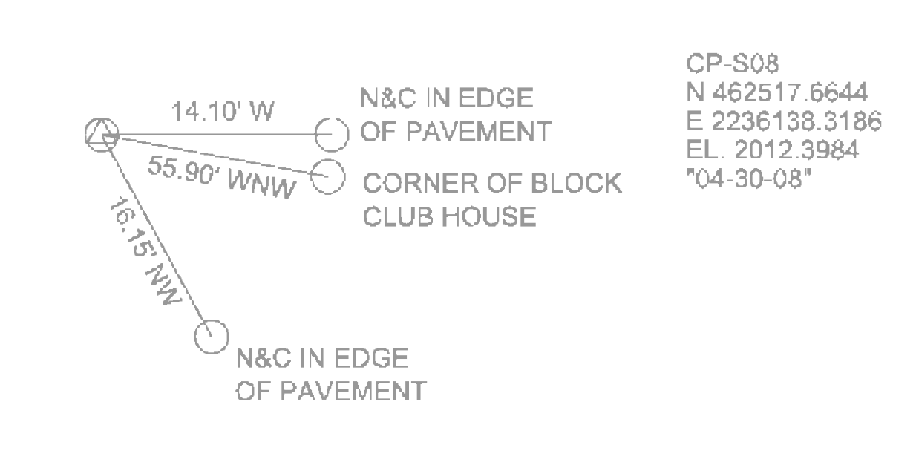
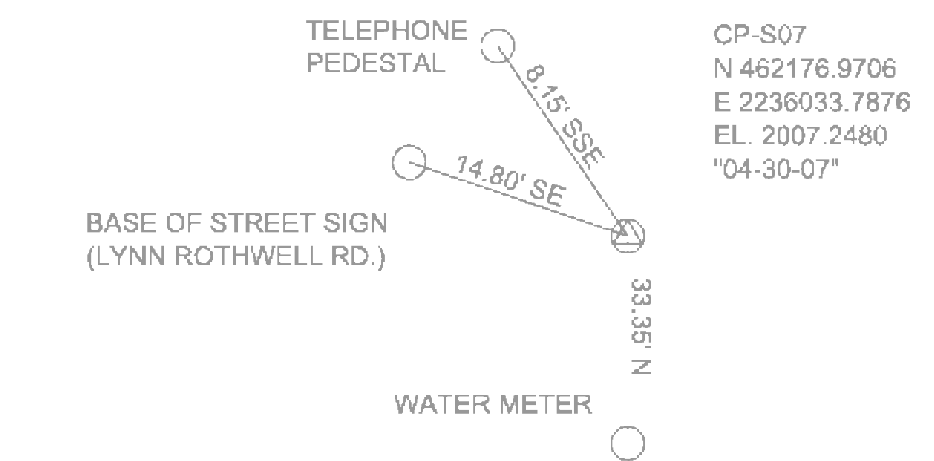

SS BEGINNING AT THE RHEA/BLEDSE COUNTY LINE ON SR-30 SE OF PIKEVILLE, GO WEST ON SR-30 0.56 MILES TO SUMMER CITY ON THE RIGHT, TURN RIGHT ONTO SUMMER CITY ROAD AND GO 2.12 TO LYNN ROTHWELL ROAD ON THE LEFT, TURN LEFT ONTO LYNN ROTHWELL ROAD AND GO 0.01 MILES TO 04-30-07. STATION IS ON THE LEFT.

BEGINNING AT THE RHEA/BLEDSE COUNTY LINE ON SR-30 SE OF PIKEVILLE, GO WEST ON SR-30 0.56 MILES TO SUMMER CITY ON THE RIGHT, TURN RIGHT ONTO SUMMER CITY ROAD AND GO 2.12 TO LYNN ROTHWELL ROAD ON THE LEFT, TURN LEFT ONTO LYNN ROTHWELL ROAD AND GO 0.08 MILES TO 04-30-08. STATION IS ON THE LEFT.

CURVE 04JRI11  
LYNN ROTHWELL RD.  
P: 202+13.55  
N 462,220.1759  
E 2,235,060.4562  
D 8' 25" 04" (L)  
L 6' 00" 30"  
R 954.93  
L 140.30  
T 70.28  
SE 0.034 FT/FT  
DESIGN SPEED 25 MPH  
TRANS. LENGTH 93.75

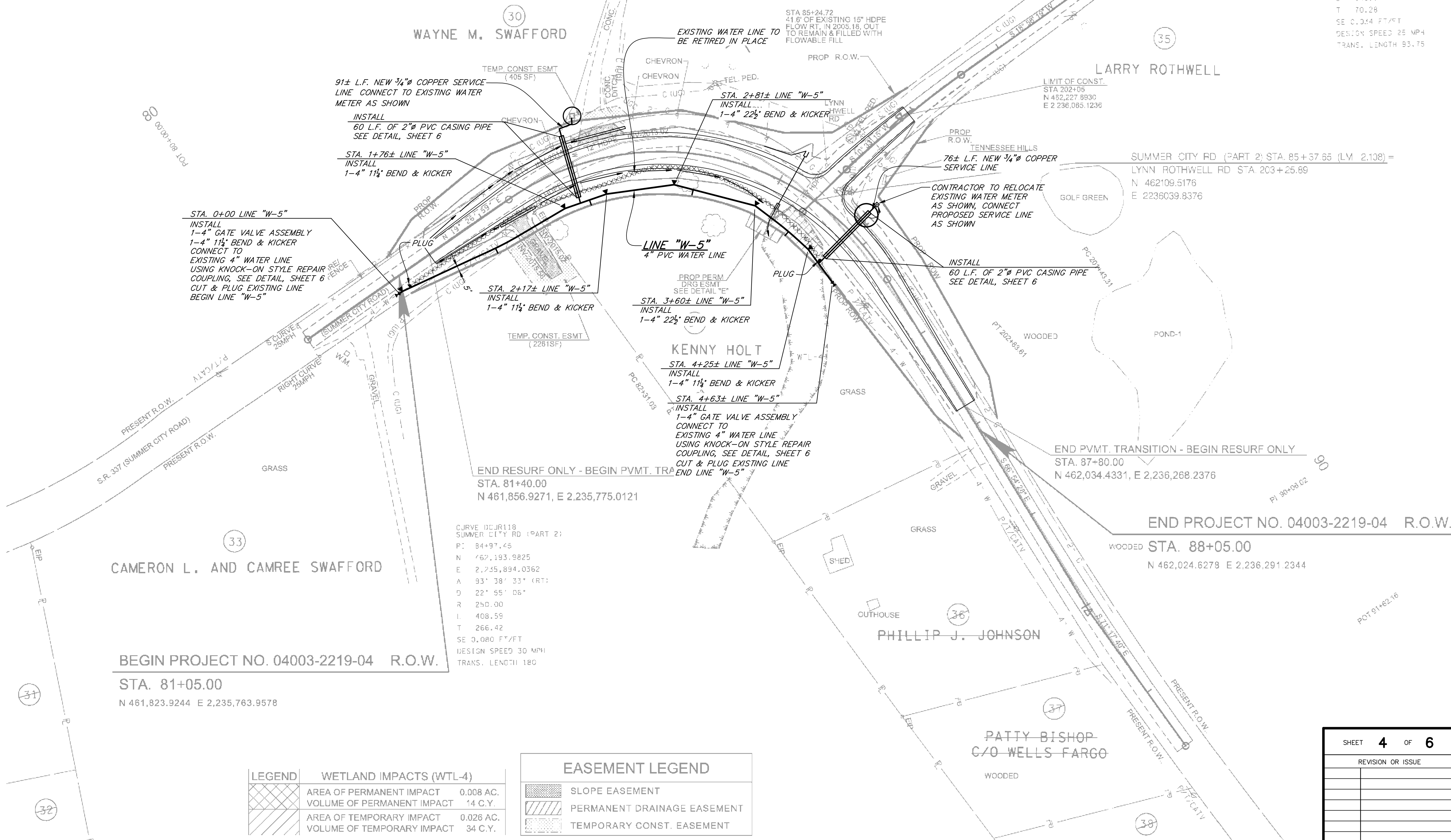

- CONSTRUCTION NOTES:**
- SEE "GENERAL NOTES" AND "LEGEND" ON SHEET 1.
  - IT IS THE CONTRACTOR'S RESPONSIBILITY TO POTHOLE EXISTING UTILITIES WELL IN ADVANCE OF PIPE LAYING ACTIVITIES TO DETERMINE CONFLICTS. NO EXTRA PAYMENT WILL BE MADE RELATED TO CONFLICTS WITH EXISTING UTILITIES.
  - ALL FITTINGS SHALL UTILIZE MEGALUG RESTRAINT GLANDS AND CONCRETE KICKERS.
  - THE CONTRACTOR SHALL REESTABLISH THE PROPOSED TDOT ROADWAY AND RIGHT-OF-WAY ALIGNMENT PRIOR TO INSTALLING PIPELINES.

LEGEND	WETLAND IMPACTS (WTL-4)
[Cross-hatched pattern]	AREA OF PERMANENT IMPACT 0.008 AC.
[Diagonal lines pattern]	VOLUME OF PERMANENT IMPACT 14 C.Y.
[Dotted pattern]	AREA OF TEMPORARY IMPACT 0.026 AC.
[Horizontal lines pattern]	VOLUME OF TEMPORARY IMPACT 34 C.Y.

EASEMENT LEGEND	
[Diagonal lines pattern]	SLOPE EASEMENT
[Horizontal lines pattern]	PERMANENT DRAINAGE EASEMENT
[Dotted pattern]	TEMPORARY CONST. EASEMENT

SHEET 4 OF 6	<b>WATER SYSTEM IMPROVEMENTS</b>	
REVISION OR ISSUE	CONTRACT 23-01 SUMMER CITY ROAD WATER RELOCATION	
	<b>LINE "W-5" - STA. 0+00 TO E.O.L.</b>	
	FOR DAYTON, TENNESSEE	
SCALE 1"=50'	DESIGNED DGT	
DATE MAR. 2024	DRAWN RSS	
PROJECT NUMBER 4657	CHECKED JGD	



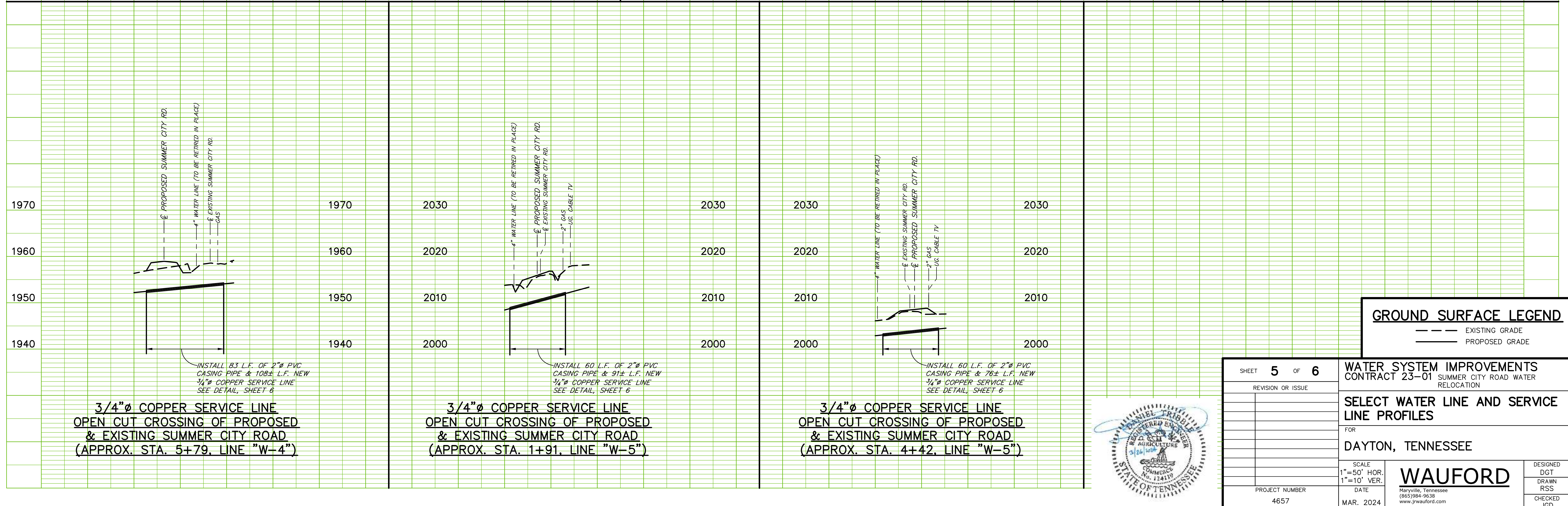
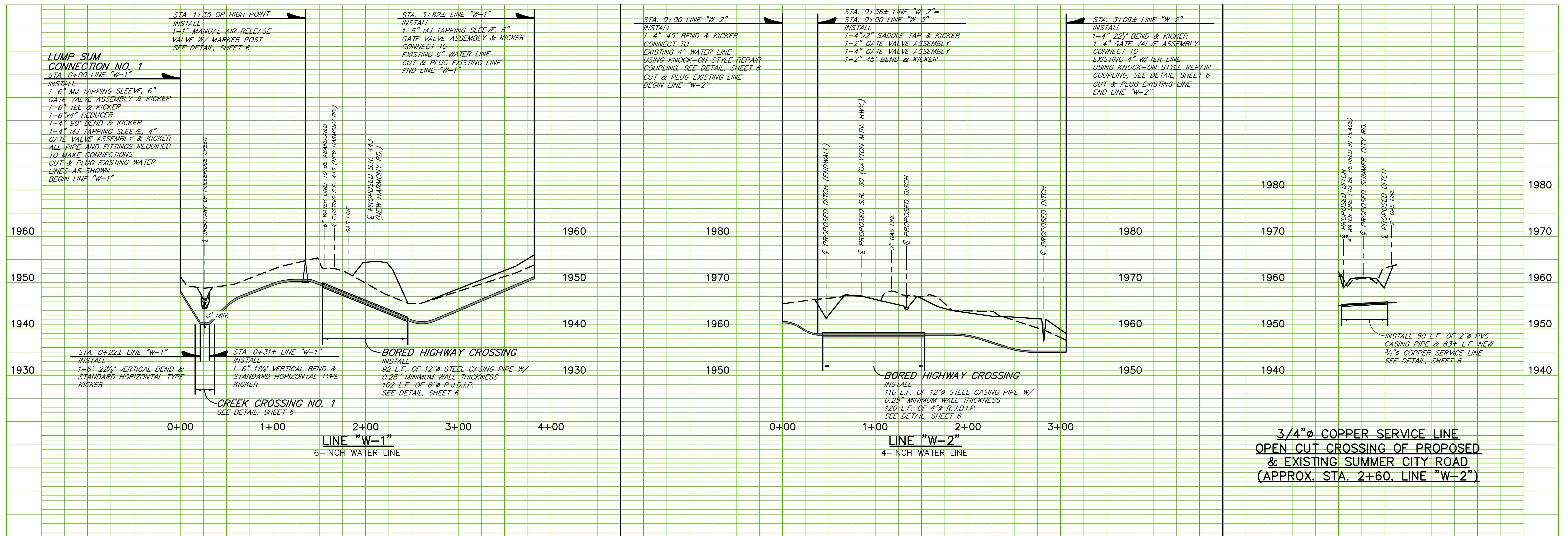

**GROUND SURFACE LEGEND**  
 --- EXISTING GRADE  
 ——— PROPOSED GRADE

SHEET <b>5</b> OF <b>6</b>	<b>WATER SYSTEM IMPROVEMENTS</b> CONTRACT 23-01 SUMMER CITY ROAD WATER RELOCATION
REVISION OR ISSUE	<b>SELECT WATER LINE AND SERVICE LINE PROFILES</b>
	FOR <b>DAYTON, TENNESSEE</b>
PROJECT NUMBER 4657	SCALE 1"=50' HOR. 1"=10' VER. DATE MAR. 2024
	<b>WAUFORD</b> Maryville, Tennessee (865)984-9638 www.jrwauford.com
	DESIGNED DGT DRAWN RSS CHECKED JGD





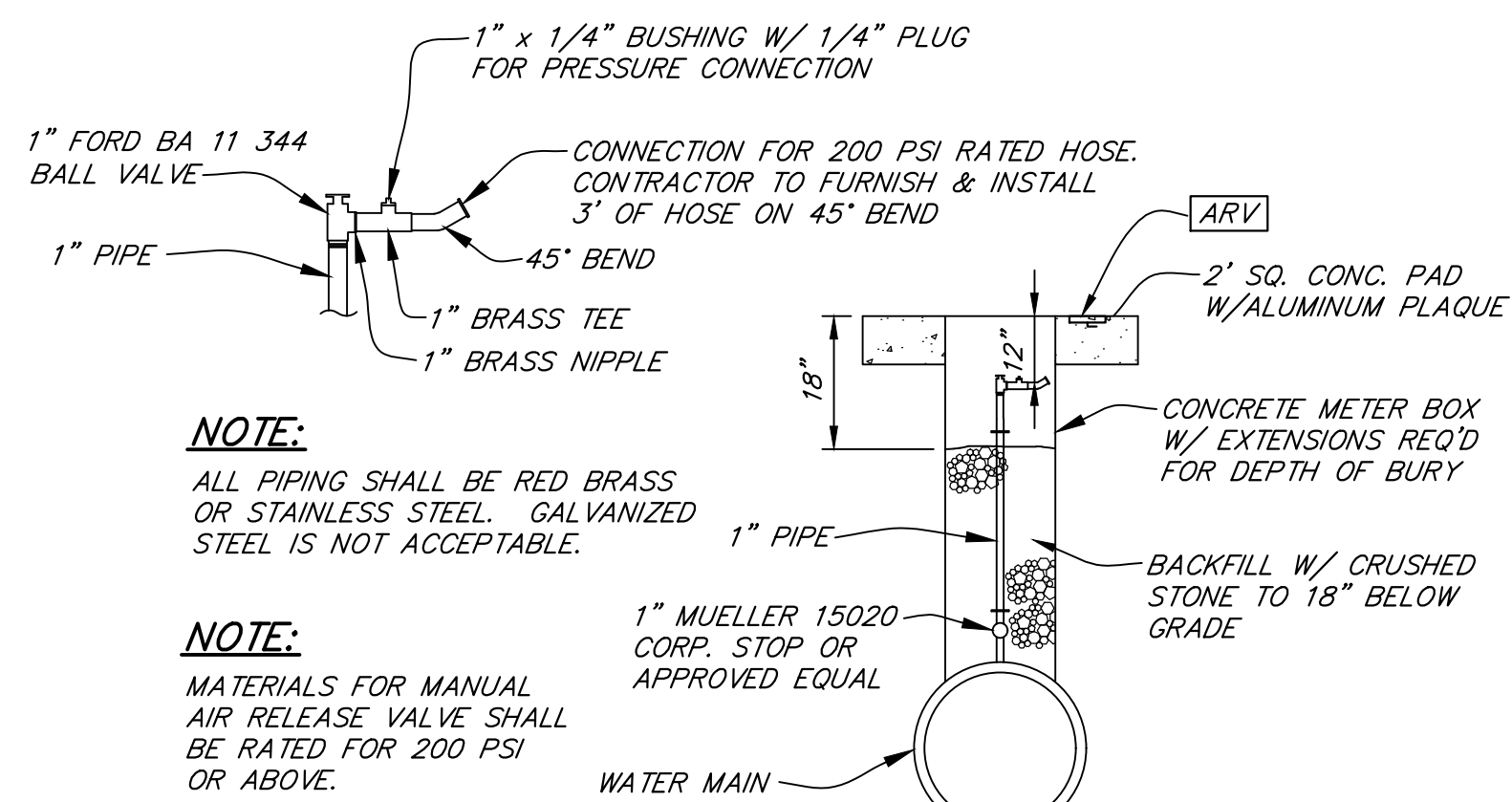

**NOTE:**

ALL PIPING SHALL BE RED BRASS OR STAINLESS STEEL. GALVANIZED STEEL IS NOT ACCEPTABLE.

**NOTE:**

MATERIALS FOR MANUAL AIR RELEASE VALVE SHALL BE RATED FOR 200 PSI OR ABOVE.

**1" MANUAL AIR RELEASE VALVE ASSEMBLY**

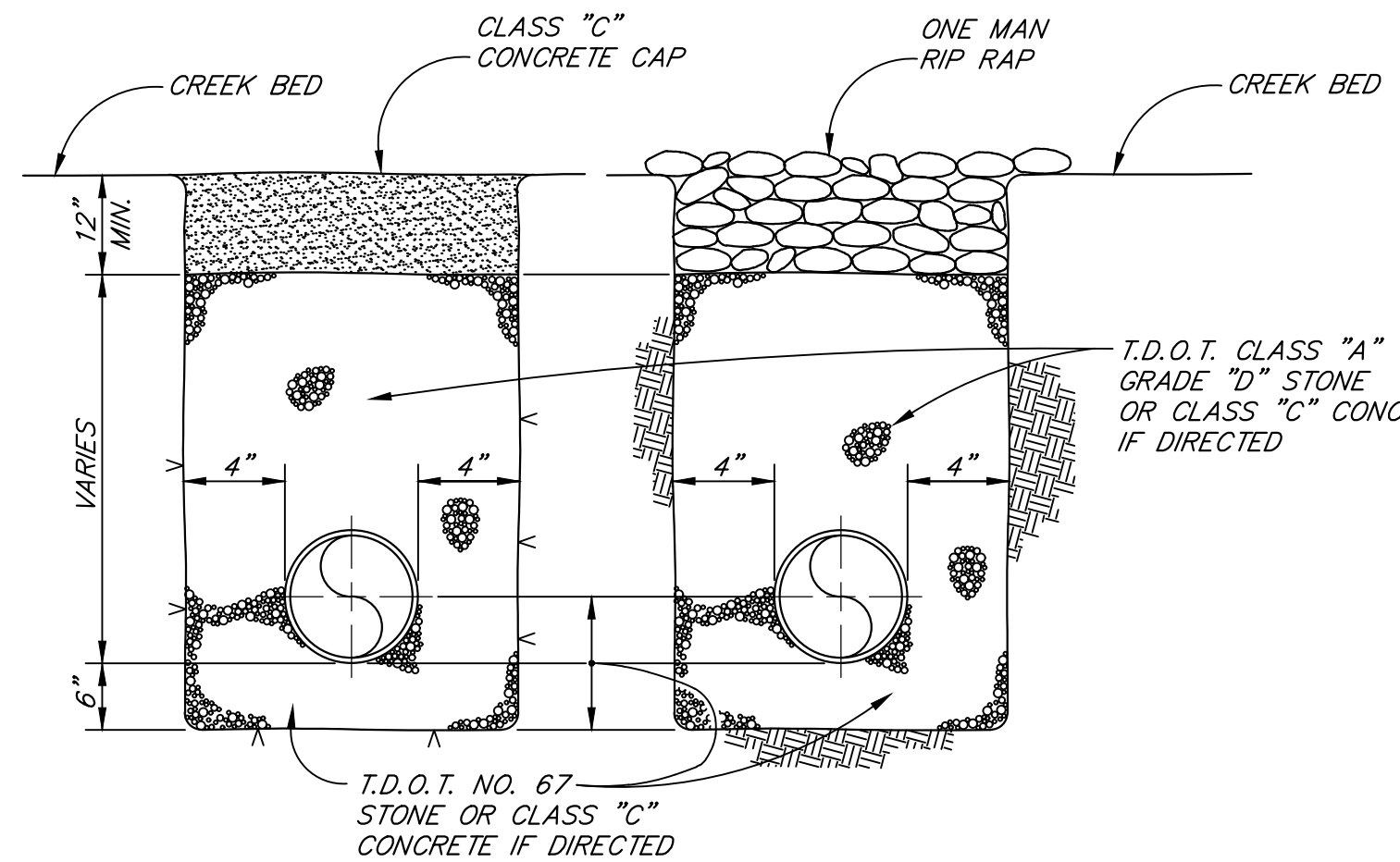

**TYPICAL CREEK CROSSING**

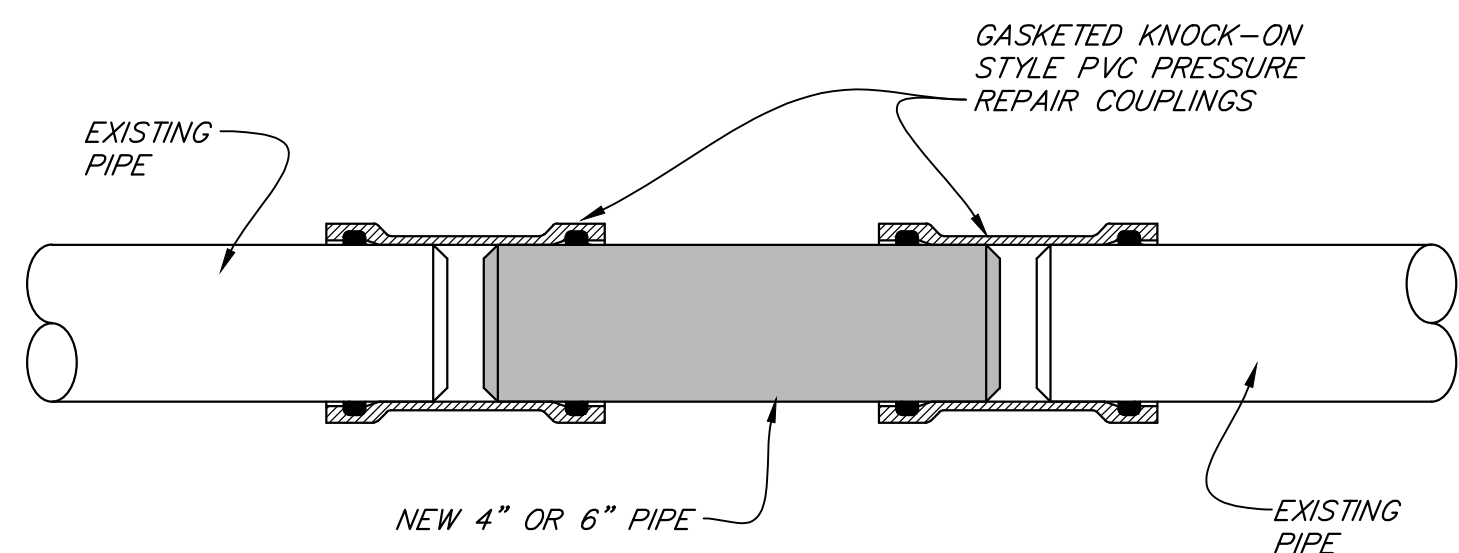

**KNOCK-ON STYLE REPAIR COUPLING**

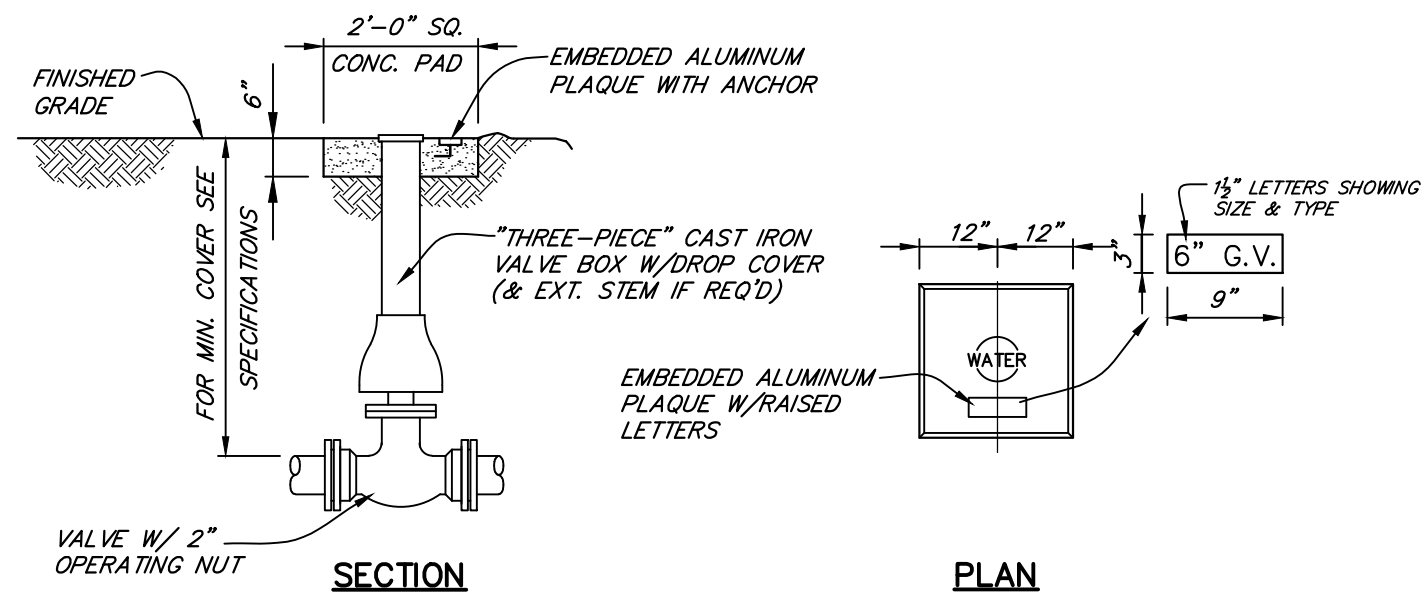

**TYPICAL LINE VALVE SETTING**

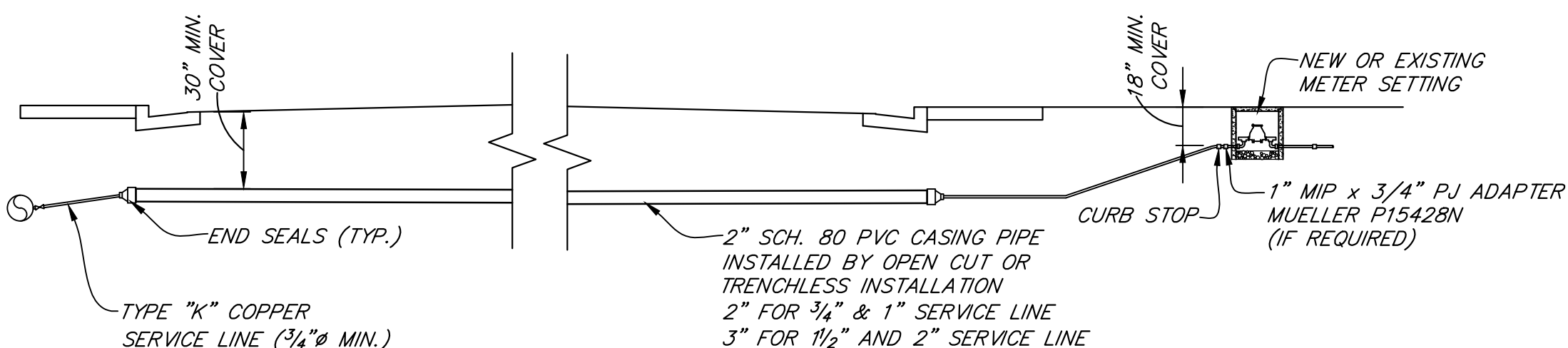

**TYPICAL SERVICE LINE CROSSING HIGHWAY**

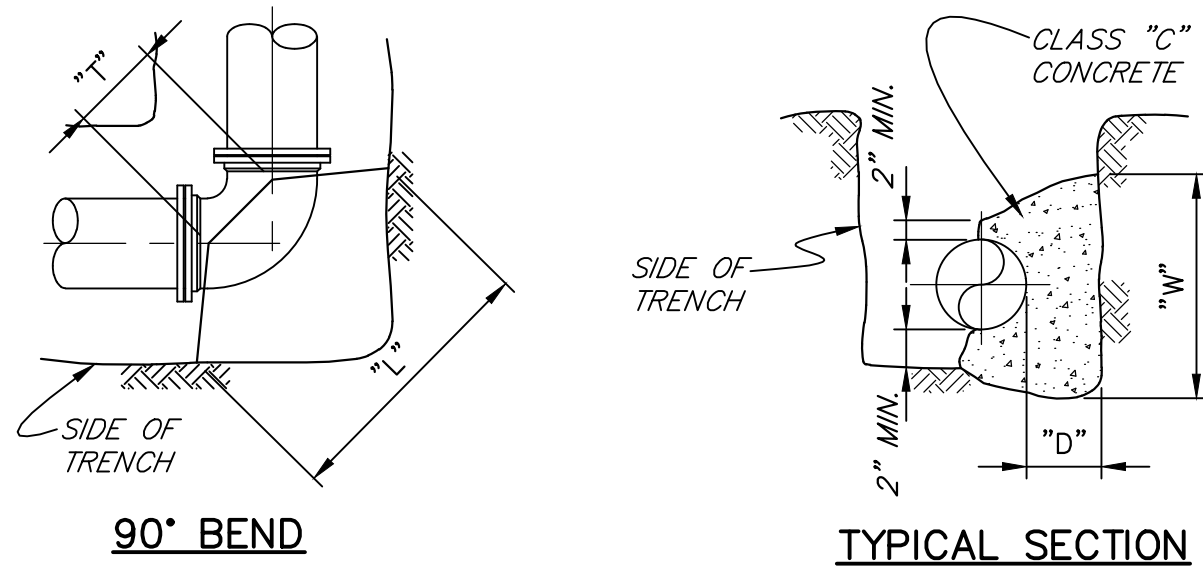

**90° BEND**

**TYPICAL SECTION**

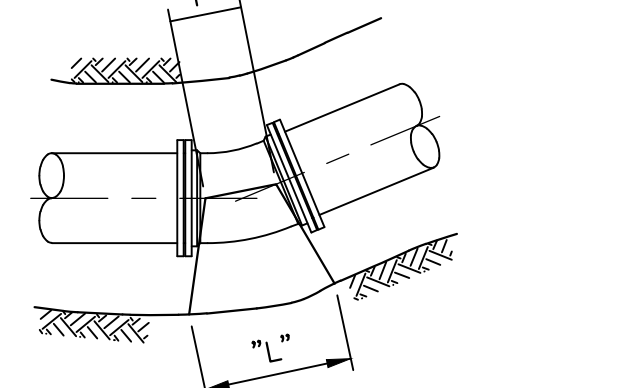

**45°, 22½° & 11¼° BENDS**

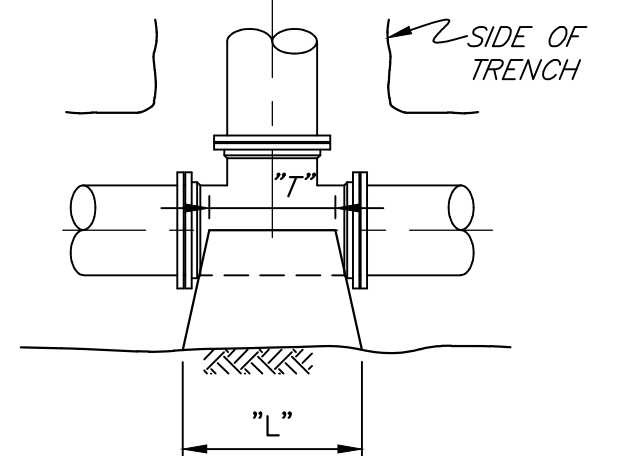

**TEE**

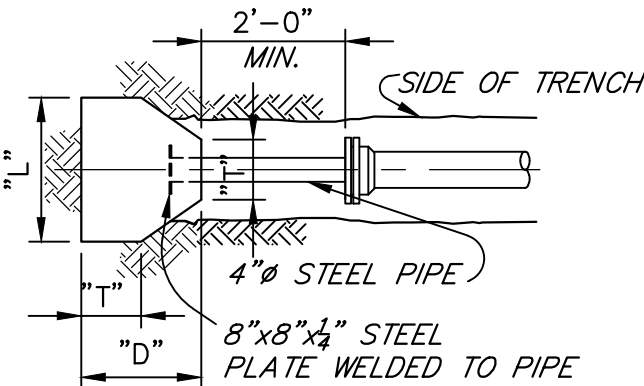

**PLUG**

BEARING PRESSURE 3000 PSF PSI = 100			
90° BEND			
SIZE	2"	4"	6"
D	9	12	12
L	9	17	24
W	9	17	24
T	4	8	10

45° BEND			
SIZE	2"	4"	6"
D	9	10	10
L	7	13	18
W	7	13	18
T	4	7	9

22½° & 11¼° BENDS			
SIZE	2"	4"	6"
D	9	10	10
L	6	9	14
W	6	9	14
T	4	7	9

TEE			
SIZE	2"	4"	6"
D	9	12	12
L	7	14	21
W	7	14	21
T	8	12	16

PLUG			
SIZE	2"	4"	6"
D	9	10	15
L	7	20	30
W	7	20	30
T	8	10	15

PLUG			
SIZE	2"	4"	6"
D	9	10	15
L	7	20	30
W	7	20	30
T	8	10	15

PLUG			
SIZE	2"	4"	6"
D	9	10	15
L	7	20	30
W	7	20	30
T	8	10	15

PLUG			
SIZE	2"	4"	6"
D	9	10	15
L	7	20	30
W	7	20	30
T	8	10	15

PLUG			
SIZE	2"	4"	6"
D	9	10	15
L	7	20	30
W	7	20	30
T	8	10	15

PLUG			
SIZE	2"	4"	6"
D	9	10	15
L	7	20	30
W	7	20	30
T	8	10	15

PLUG			
SIZE	2"	4"	6"
D	9	10	15
L	7	20	30
W	7	20	30
T	8	10	15

PLUG			
SIZE	2"	4"	6"
D	9	10	15
L	7	20	30
W	7	20	30
T	8	10	15

PLUG			
SIZE	2"	4"	6"
D	9	10	15
L	7	20	30
W	7	20	30
T	8	10	15

PLUG			
SIZE	2"	4"	6"
D	9	10	15
L	7	20	30
W	7	20	30
T	8	10	15

PLUG			
SIZE	2"	4"	6"
D	9	10	15
L	7	20	30
W	7	20	30
T	8	10	15

PLUG			
SIZE	2"	4"	6"
D	9	10	15
L	7	20	30
W	7	20	30
T	8	10	15

PLUG			
SIZE	2"	4"	6"
D	9	10	15
L	7	20	30
W	7	20	30
T	8	10	15

PLUG			
SIZE	2"	4"	6"
D	9	10	15
L	7	20	30
W	7	20	30
T	8	10	15

PLUG			
SIZE	2"	4"	6"
D	9	10	15
L	7	20	30
W	7	20	30
T	8	10	15

PLUG			
SIZE	2"	4"	6"
D	9	10	15
L	7	20	30
W	7	20	30
T	8	10	15

PLUG			
SIZE	2"	4"	6"
D	9	10	15
L	7	20	30
W	7	20	30
T	8	10	15

PLUG			
SIZE	2"	4"	6"
D	9	10	15
L	7	20	30
W	7	20	30
T	8	10	15

PLUG			
SIZE	2"	4"	6"
D	9	10	15
L	7	20	30
W	7	20	30
T	8	10	15

PLUG			
SIZE	2"	4"	6"
D	9	10	15
L	7	20	30
W	7	20	30
T	8	10	15

PLUG			
SIZE	2"	4"	6"
D	9	10	15
L	7	20	30
W	7	20	30
T	8	10	15

PLUG			
SIZE	2"	4"	6"
D	9	10	15
L	7	20	30
W	7	20	30
T	8	10	15

PLUG			
SIZE	2"	4"	6"
D	9	10	15
L	7	20	30
W	7	20	30
T	8	10	15

PLUG			
SIZE	2"	4"	6"
D	9	10	15
L	7	20	30
W	7	20	30
T	8	10	15

PLUG			
SIZE	2"	4"	6"
D	9	10	15
L	7	20	30
W	7	20	30
T	8	10	15

**NOTES**

- FOR TEE WITH BRANCH UNEQUAL TO RUN, USE TEE TYPE KICKER WITH D, L & W DIMENSIONS THE SAME AS THOSE FOR PLUG WITH SAME DIMENSIONS AS BRANCH OF TEE. SELECT T DIMENSION FROM TEE TABLE UNDER COLUMN HEADED BY THE SIZE OF THE BRANCH.
- IF EXACT SIZE OF PIPE BLOCKING IS NOT SHOWN, USE NEXT LARGER SIZE.
- DIMENSION D MAY BE GREATER THAN SPECIFIED TO ALLOW WORKING SPACE. CONCRETE BLOCKING MUST BE POURED AGAINST UNDISTURBED EARTH.

**CLASS "C" CONCRETE BLOCKING FOR PIPE (KICKERS)**

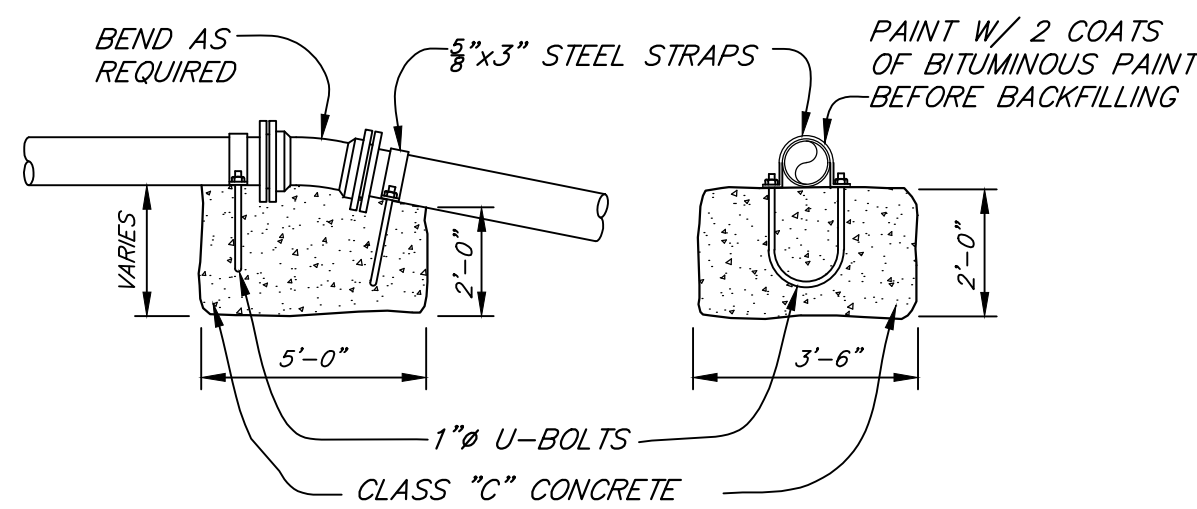

**VERTICAL ANCHORING DETAIL FOR VERTICAL BENDS 5° OR MORE**

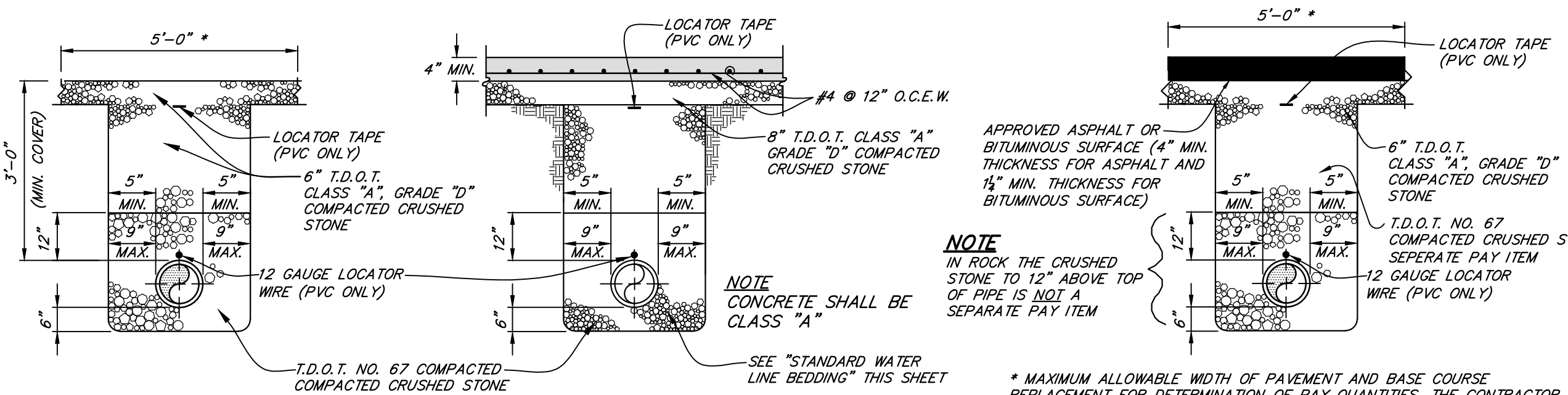

**GRAVEL SURFACE CONCRETE DRIVEWAY REPLACEMENT**

**ASPHALT OR BITUMINOUS SURFACE**

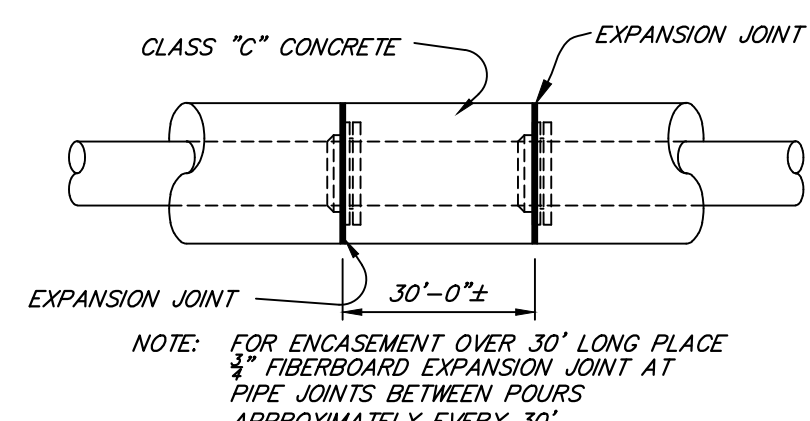

**STANDARD CONCRETE ENCASMENT**

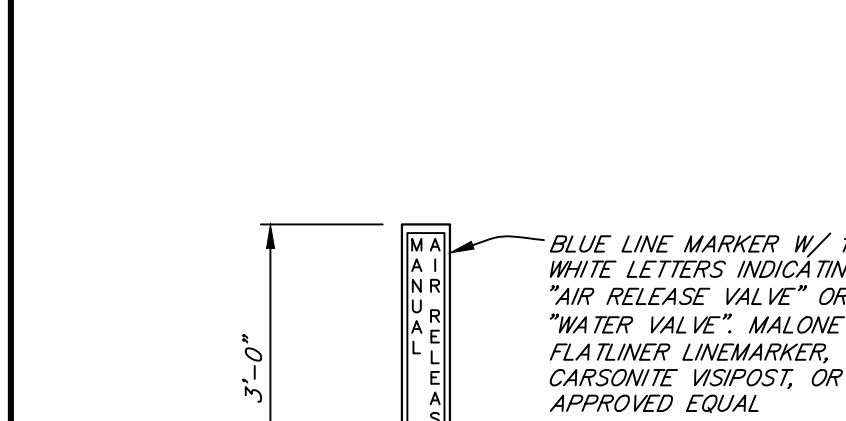

**FIBERGLASS MARKER PLACARD**

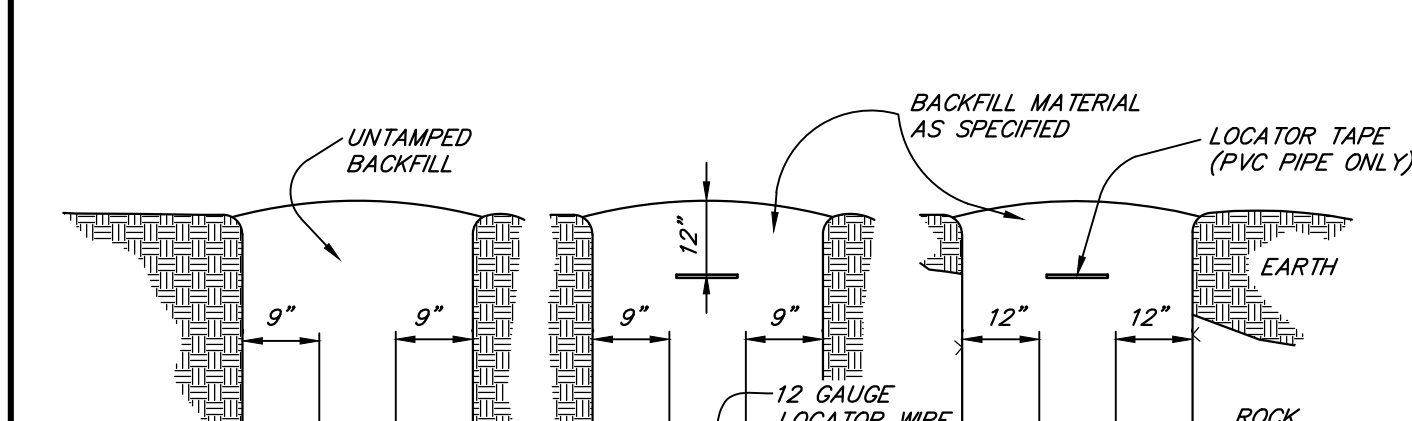

**STANDARD WATER LINE BEDDING**

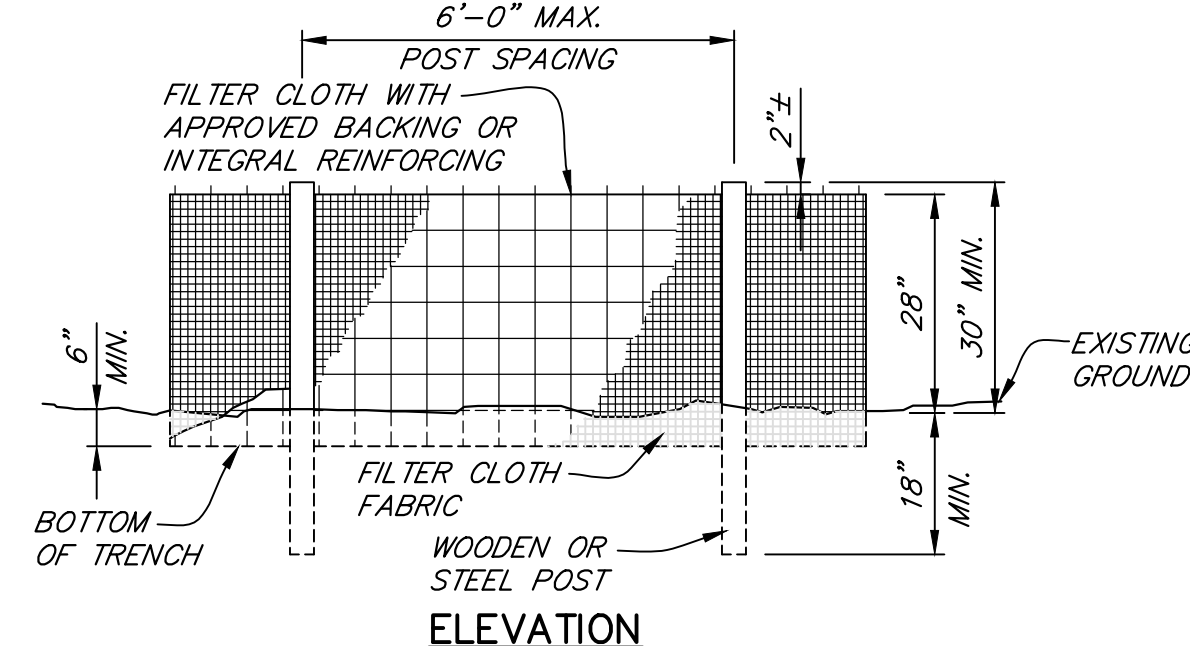

**NOTES:**

- FILTER CLOTH SHALL HAVE APPROVED BACKING OR AN INTEGRAL REINFORCING AS RECOMMENDED BY THE MANUFACTURER TO SUPPORT THE FILTER CLOTH.
- A PREASSEMBLED SILT FENCE MEETING THE REQUIREMENTS OF THIS DRAWING IS ACCEPTABLE IN LIEU OF A FIELD CONSTRUCTED SILT FENCE.

**STANDARD TEMPORARY SILT FENCE**

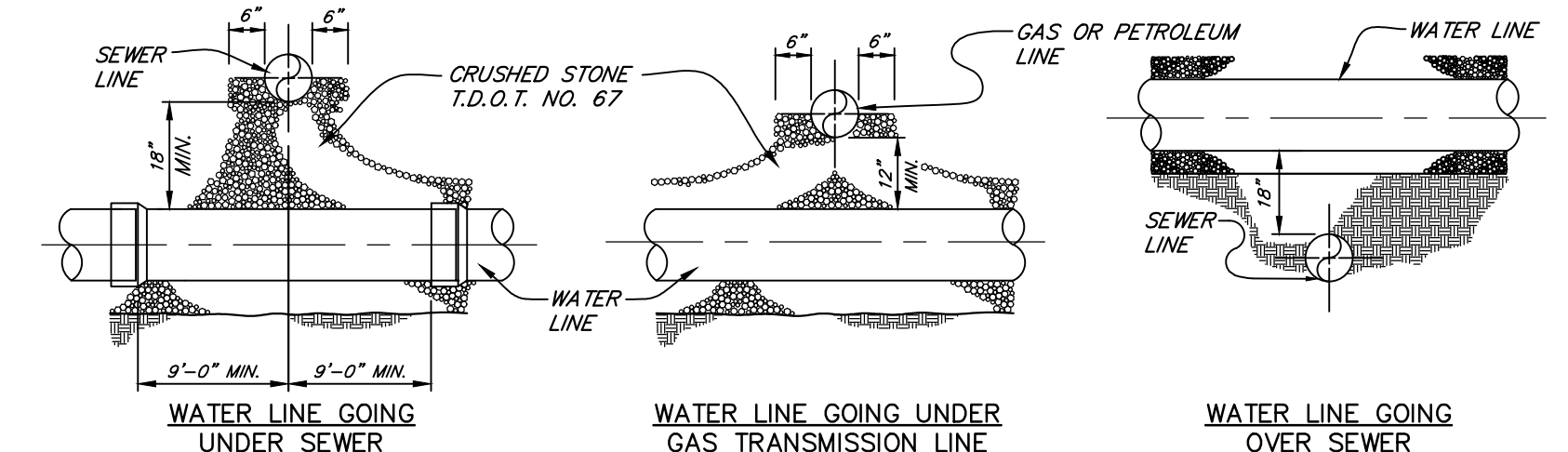

**TYPICAL PIPE CROSSING**

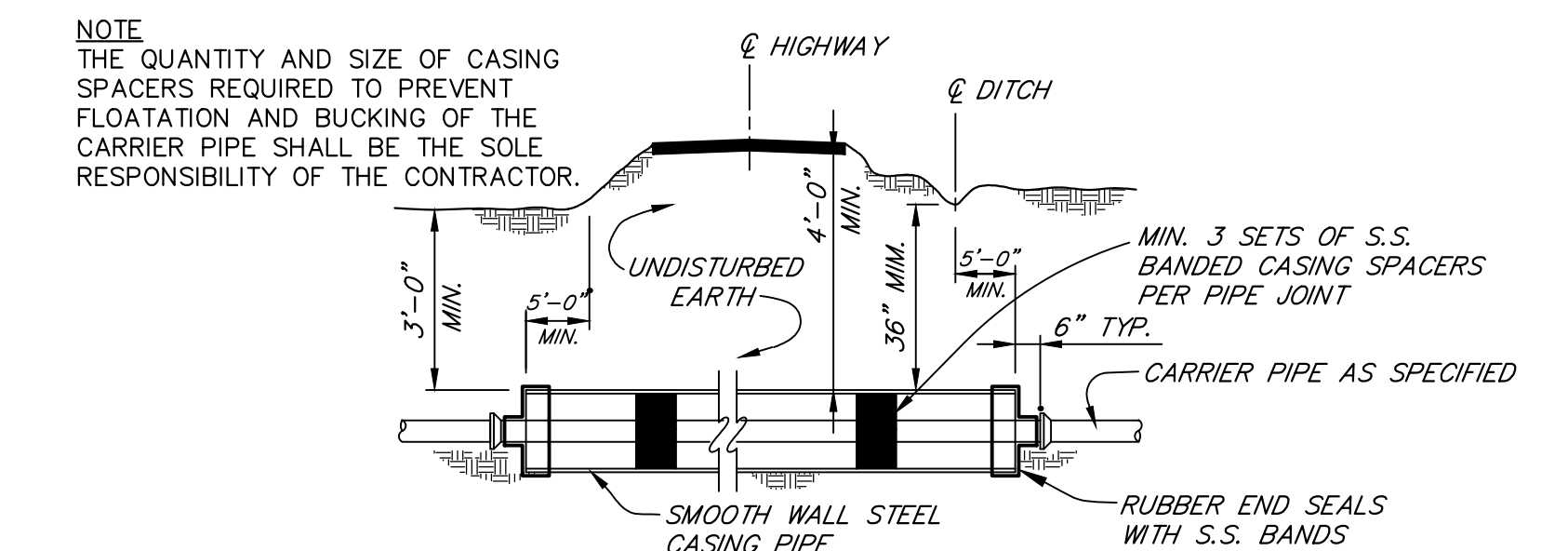

**BORED HIGHWAY CROSSING DETAIL**

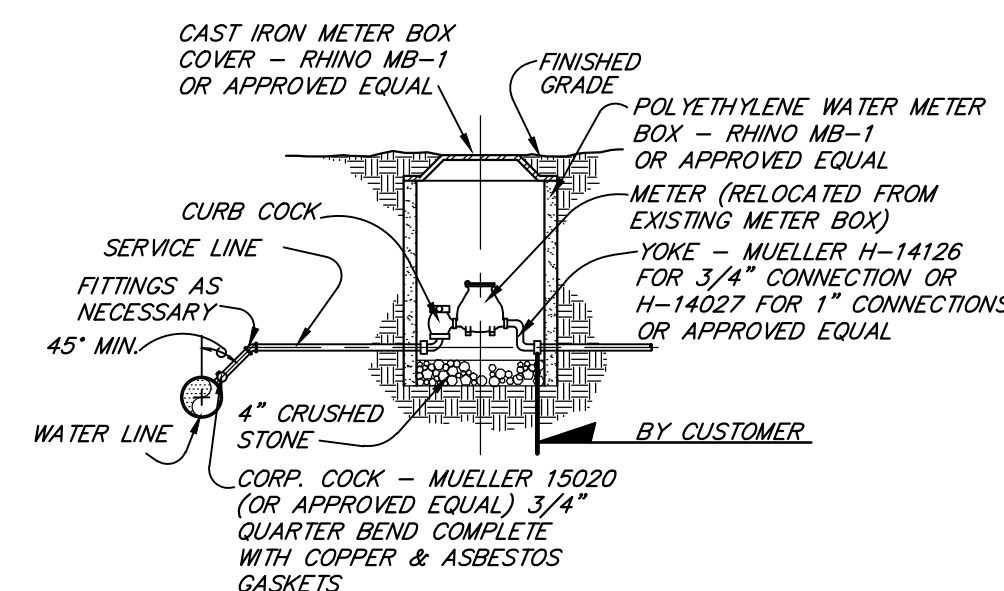

**METER SETTING FOR 3/4" OR 1" SERVICES**

SHEET	6 OF 6	<b>WATER SYSTEM IMPROVEMENTS</b> CONTRACT 23-01 SUMMER CITY ROAD WATER RELOCATION
REVISION OR ISSUE		
		<b>DETAIL SHEET</b>
		FOR <b>DAYTON, TENNESSEE</b>
		SCALE NO SCALE
		DESIGNED DGT
		DRAWN RSS
		CHECKED JGD
PROJECT NUMBER	4657	DATE MAR. 2024
		<b>WAUFORD</b> Maryville, Tennessee (865)984-9638 www.jrwauford.com

