

**INVITATION TO BID
RE-BID SHELTON RD. WWTP OXIDATION DITCH
ROTOR REPLACEMENT**

TC2024-42

**TOWN OF COLLIERVILLE
GENERAL SERVICES DEPARTMENT
500 POPLAR VIEW PARKWAY
COLLIERVILLE, TENNESSEE 38017**



**TOWN OF COLLIERVILLE
PUBLIC UTILITIES DEPARTMENT**

BID PACKAGE CONSISTS OF:

BID PROJECT DIRECTORY

BID SITE PLANS

TOWN OF COLLIERVILLE BID ENVELOPE

The Town of Collierville does not discriminate on the basis of race, color, national origin, age, sex or disability in its hiring and employment practices, or in admission to, access to, or operation of its programs, the Civil Rights Act of 1964 (42 U.S.C. 200d) and the Americans with Disabilities Act of 1990, Pub. L 101-336. If you need accommodations, please call 457-2212.

*FINAL FORM
All Other Previous Forms Superseded
As of December 2022*

TABLE OF CONTENTS

FOR

RE-BID SHELTON RD. WWTP OXIDATION DITCH ROTOR REPLACEMENT

Advertisement for Bids	A
Special Notice	B
Information for Bidders	C-1 thru C-7
Drug and Alcohol Testing Policy	D-1 thru D-2
Title VI Information	E-1 thru E-2
Bid Form	F-1 thru F-4
Certification of Compliance	F-5 thru F-11
Documentation of Entity Status (Sam.gov Status)	F-12
Addenda Acknowledgement Form	F(A-1)
Bid Bond	G
Information for Successful Bidder	H-1 thru H-3
Contract and Agreement	I-1 thru I-9
Payment Bond	J-1 thru J-3
Performance Bond	K-1 thru K-3
Collierville Insurance Requirement	L-1 thru L-5
Certificate of Payment to Contractor	M-1 thru M-2
Notice of Award	N
Notice to Proceed	O
Notice of Project Acceptance	P
Change Order Form	Q
General Provisions	GP-1 thru GP-31
Special Conditions	SC-1 thru SC-1

SPECIFICATIONS

Shelton Road Wastewater Treatment Plant Oxidation
Ditch Rotor Replacement Scope And Specifications

Page 1 - 5

CONSTRUCTION DRAWINGS/ATTACHMENTS

Attachment A.	Original Rotor Bid Specifications
Attachment B.	Project Site Location
Attachment C.	Oxidation Ditch #1
Attachment D.	Oxidation Ditch #2
Attachment E.	Electrical Locations
Attachment F.	Control Locations
Attachment G	Ditch #1 Rotor
Attachment H.	Ditch #2 Rotor
Attachment I.	Other Related Drawings
Attachment J.	TN State Water Infrastructure Grant Identification Sign Diagram

LEGAL NOTICE TO BIDDERS

The Town of Collierville Procurement Division is requesting sealed bids on the following items:

BID # TC2024-42 RE-BID SHELTON RD. WWTP OXIDATION DITCH ROTOR REPLACEMENT

Bid Deadline: September 4, 2024, at 2:00:00 p.m. (local time)

Complete bid packages are available from the Procurement Division, 500 Poplar View Parkway, Collierville, TN 38017, Monday through Friday, 8 a.m. to 5 p.m. Interested parties may visit the Procurement Division's Bid and RFP webpage at <http://collierville.com/departments/general-services/bids-and-rfps> or call 901-457-2250 for further solicitation information.

Deadline for sealed bids, submitted to the Procurement Division, 500 Poplar View Parkway, Collierville, TN 38017, is as noted per project listed above. The bids will then or soon thereafter be publicly opened and read aloud in the Town Board Chambers at 500 Poplar View Parkway, Collierville, Tennessee.

Bid packages must be clearly marked on the outside of the provided opaque Town of Collierville—Official Bid Envelope. BID # TC2024-42 RE-BID SHELTON RD. WWTP OXIDATION DITCH ROTOR REPLACEMENT.

Each BID must be submitted on forms provided in the BID PACKET DOCUMENTS provided and either accompanied by a BID BOND, properly executed on the form provided, or a Certified or Cashier's check drawn on a National or Tennessee Bank or a Letter of Credit, properly executed, in the amount of five percent (5%) of the TOTAL BID PRICE and payable to the TOWN OF COLLIERVILLE. Upon execution of a CONTRACT, the CONTRACTOR will be required to have executed and maintain good and solvent PAYMENT and PERFORMANCE BONDS in the amount of 100% of the CONTRACT price, which BONDS must remain in the amount of 100% of the CONTRACT price, **including any amendment thereto**, for the duration of the PROJECT.

For construction PROJECTS, the Bidder's license number, its expiration date, and that part of the classification applying to the BID, together with certain information regarding SUBCONTRACTORS, must appear on the envelope containing the BID, otherwise the BID shall not be opened or considered. For additional details on this requirement, see the attached document headed "INFORMATION FOR BIDDERS" (**Document C**). The successful BIDDER shall be prohibited from discriminating against any individual due to the individual's race, creed, color, national origin, age, sex, disability, religion, or any other protected class under applicable law.

The Town of Collierville reserves the right to reject any and all bids, accept bids in part or whole, waive defects, informalities or minor irregularities in bids or bid process and to make bid awards, as deemed, to be in its best interest.

During the competitive bid process, Bidders are instructed not to contact the employees of the using departments concerning this Bid Request. The ONLY official position of the Town is that position which is stated in writing and issued by the Procurement Division. No other means of communication, whether written or oral, shall be construed as a formal or official response statement.

SPECIAL NOTICE

DOCUMENTS:

All BIDDERS bidding on construction projects for the TOWN are required to use the documents contained herein.

TOC CONSTRUCTION STANDARDS:

Where expressly noted in the BID PACKET DOCUMENTS, TOC CONSTRUCTION STANDARDS are specifications listed in the Town of Collierville Standard Construction Specifications and Town of Collierville Standard Details and are available to all BIDDERS on the TOWN'S Engineering Division webpages at www.colliervilletn.gov or by contacting the Engineering Division by email at engineering@colliervilletn.gov or by telephone at (901) 457-2340.

INSURANCE:

It is highly recommended that BIDDERS consult with their insurance agent(s) to assure themselves that they can obtain the required insurance coverage set out in the Insurance Documents (**Insurance Requirement Section, L-1 through L-5**) and that their insurance agent(s) is authorized to execute the required Certificate of Insurance Coverage, including, without limitation, the minimum insurance coverages specified on page L-1 hereof.

DOCUMENTS TO BE EXECUTED:

A BIDDER should only execute the BID and BID BOND, DRUG AND ALCOHOL ACKNOWLEDGMENT STATEMENT AND AFFIDAVIT (**Form D-2**), and ADDENDA ACKNOWLEDGMENT FORM (**Form F (A-1)**), if any, when making a BID. (Alternatively, a Certified or Cashier's check drawn on a National or Tennessee Bank or a Letter of Credit, properly executed, in the amount of five percent (5%) of the TOTAL BID PRICE and payable to the TOWN OF COLLIERVILLE may be accepted in lieu of a BID BOND.) The remaining forms contained in the CONTRACT DOCUMENTS will be required to be executed and complied with only by the successful BIDDER after notice of the award has been issued.

ADDITIONAL INFORMATION:

General and/or technical questions relating to this solicitation shall be submitted in writing to the TOWN DIRECTOR OF GENERAL SERVICES, Office of General Services, by mail at 500 Poplar View Parkway, Collierville, TN 38017; by fax number 901-457-2258; or by email at tocpurchasing@colliervilletn.gov. The following information must be included in any general and/or technical questions submitted: *Vendor Number, Contact Name, Company Name and Address, Telephone and Fax Number, BID Number, and BID Due Date.

INFORMATION FOR BIDDERS

NOTICE – It is necessary for prospective BIDDERS to carefully read the information contained below to understand exactly how to submit a BID, what documents must accompany the BID, what information should be on the outside of the envelope containing the BID, what the BIDDER legally obligates itself for by submitting a BID, and the reason why the TOWN included the other Documents in this BID PACKET. Failure to carefully read and understand the information contained below may either cause the BIDDER'S BID not to be considered or accepted by the TOWN or cause the BIDDER to legally obligate itself to more than it realizes. The BID DOCUMENT and the other documents contained in this BID PACKET are legal documents. If the BIDDER does not understand any of them, the BIDDER should consult with its attorney. Only the document forms included in this BID PACKET may be used.

Please Note: As a part of doing business with the TOWN, each BIDDER is required to obtain a Vendor Number to reference when submitting a BID RESPONSE FORM. **Failure to do so may result in the disqualification of the BID.** The Vendor Number may be obtained by accessing the TOWN's vendor registration site and registering as a TOWN vendor at <http://tocpurchasing.collierville.tn.gov/bsa>. If you have any questions regarding the Vendor Number, please call the TOWN'S Procurement Division at (901) 457-2253.

1. Each BID must be submitted on the form provided in this BID PACKET and be accompanied either by a BID BOND, properly executed, on the form provided (**Document G**) or a Certified or Cashier's check drawn on a National or Tennessee Bank or a Letter of Credit, properly executed, in the amount of five percent (5%) of the TOTAL BID PRICE and payable to the TOWN OF COLLIERVILLE.

The BID BOND must be considered good and solvent by the TOWN. A good and solvent bond means a bond (1) written by a surety or insurance company listed on the United States Department of the Treasury Financial Management Service (FMS) list of approved bonding companies, (2) written for an amount which is less than or equal to the amount indicated as approved for the surety or insurance company by the FMS, and (3) is written by a surety or insurance company that is licensed and authorized to do business as a surety or insurer in the State of Tennessee.

If a Certified or Cashier's check, as stated above, is supplied, a deposit slip will be completed for the transaction and the check will be deposited within no more than three business days after the initial collection, as required by state law (T.C.A. § 6-56-111) and as per TOWN standard operating procedures for cash control activities (FIN-051). Unsuccessful bidders who supplied a Certified or Cashier's check will be reimbursed by the TOWN following the award of the CONTRACT.

The TOWN may accept a Letter of Credit, in lieu of a BID BOND or Certified or Cashier's check, provided that the BIDDER has contacted the TOWN no less than seven (7) business days, without exception, prior to the BID opening date and there is sufficient time to obtain a template of the language required by the TOWN to be placed in the Letter of Credit. Failure to use the TOWN specified Letter of Credit language when submitting the Letter of Credit as stated in the

manner below shall result in a non-responsive BID.

The BID, with the BID BOND, Certified or Cashier's check, or Letter of Credit, must be placed in an Official BID Envelope, which the TOWN shall furnish to all prospective BIDDERS, and delivered to the office of the TOWN DIRECTOR OF GENERAL SERVICES, 500 Poplar View Parkway, Collierville, Tennessee 38017, on or before the time set out in the ADVERTISEMENT FOR BIDS; and then, at said office, the BID and all other BIDS shall be publicly opened and read aloud.

2. A BID shall be invalid if the BIDDER fails to deposit it at the designated location prior to the time and date for receipt of BIDS as indicated in the ADVERTISEMENT FOR BIDS. The TOWN will not consider any BID received at the TOWN'S designated location for the BID opening after the exact time specified for receipt. The TOWN shall not be responsible for, and will not accept, BIDS placed in the United States Mail or any other common carrier, but not actually received by the Town on or before the time set out in the ADVERTISEMENT FOR BIDS. The TOWN reserves the right to consider BIDS determined by the TOWN, in the TOWN'S sole discretion, to have been received late due to mishandling by the TOWN after receipt of the BID and prior to any award.

3. If necessary, and no later than forty-eight (48) hours to the date established for opening of BIDS (except as provided in Paragraph 4 below), the TOWN'S Procurement Division shall fax or e-mail ADDENDA, containing any information that the TOWN determines is material to a prospective BIDDER, to each person or firm recorded by the Procurement Division as having acquired a BID package.

4. The TOWN will not orally interpret the meaning of the plans, specifications or other BID DOCUMENTS. BIDDERS must submit all questions about the meaning or intent of BID DOCUMENTS in writing to the TOWN's DIRECTOR OF GENERAL SERVICES or his/her designated Procurement Specialist. The TOWN must receive said written questions at least five (5) business days prior to the date fixed for the opening of BIDS. The TOWN will reply to such questions with written ADDENDA faxed or e-mailed to all parties recorded by the TOWN'S Procurement Division as having acquired a BID PACKET. The TOWN'S Procurement Division shall furnish such written ADDENDA not later than forty-eight (48) hours prior to the date fixed for the opening of BIDS. Only questions answered by the TOWN in written ADDENDA will be binding; all other interpretations shall be of no effect. Failure of any BIDDER to receive any such ADDENDA shall not relieve such BIDDER from any obligation under its BID, as submitted. All ADDENDA so issued shall become part of the CONTRACT DOCUMENTS. BIDDERS shall submit all general and/or technical questions relating to the BID PACKET in writing to the TOWN DIRECTOR OF GENERAL SERVICES, or his/her designated Procurement Specialist, Office of General Services, via fax or e-mail. If any questions or responses require revisions to the solicitation as originally published, such revisions will be made by the TOWN by written ADDENDA only, as described above. No ADDENDA will be issued later than forty-eight (48) hours prior to the date for receipt of bids except an addendum withdrawing the request for bids or one which includes a revised date for receipt of bids. If the BID solicitation includes a separate contact person for technical information, BIDDERS are cautioned that any written or oral representations made by any ENGINEER, TOWN representative or other person(s) that appear to

change materially, conflict with, or modify any portion of the solicitation shall not be relied upon and shall be of no effect. Only written ADDENDA issued by the TOWN shall be effective as an amendment or as clarification of the BID solicitation. BIDDERS should contact the TOWN DIRECTOR OF GENERAL SERVICES at fax number 901-457-2258 for a determination of whether an oral or written representation of any TOWN representative or other person requires the TOWN to issue an ADDENDUM.

5. Where expressly noted in the BID PACKET DOCUMENTS, TOC CONSTRUCTION STANDARDS are specifications listed in the Town of Collierville Standard Construction Specifications and Town of Collierville Standard Details and are available to all BIDDERS on the TOWN'S Engineering Division webpages at www.colliervilletn.gov or by contacting the Engineering Division by email at engineering@colliervilletn.gov or by telephone at (901) 457-2340.

6. A BIDDER may modify or withdraw a BID by an appropriate document executed and delivered to the TOWN Procurement Division at any time prior to the appointed time for the opening of BIDS or authorized postponements thereof.

7. As applicable, the product(s) specified in the BID PACKET DOCUMENTS shall be the basis for the BID. The BIDDER shall not be allowed to substitute another product(s) or method(s) without the TOWN'S prior written approval. A BIDDER shall submit in writing any request for substitution to the TOWN'S Procurement Division no later than ten (10) business days prior to the date fixed for the opening of the BIDS. The requesting BIDDER shall submit three (3) copies of each such request for substitution, which request shall include:

- a) Complete data substantiating the compliance of the proposed substitution with the CONTRACT DOCUMENTS;
- b) For products – product identification (including manufacturer's name and address) and manufacturer's literature (including product description, performance and test data and reference standards);
- c) Sample(s);
- d) Name(s) and address(es) of similar projects on which the product was used and date of product's installation;
- e) For manufacturing methods – detailed description of the proposed methods and drawings illustrating the methods;
- f) Itemized comparison of proposed substitution with product or method specified;
- g) Data relating to changes in construction schedule; and
- h) Identification of changes or coordination required.

8. In making a request for substitution, a BIDDER represents that such BIDDER has personally investigated the proposed substituted product or method and that the BIDDER has determined that the proposed substitute products or methods are equal or superior in all respects to that originally specified, that the BIDDER will provide the same guarantee for the substitution as for the products or methods specified in the BID PACKET DOCUMENTS, and that the BIDDER will coordinate the installation of accepted substitutions into the WORK, making all

changes for the WORK to be complete in all respects.

9. Substitutions will not be considered when they are indicated or implied on shop drawings (defined as the drawn version of information shown in the CONTRACT DOCUMENTS and typically used to explain the fabrication and/or installation of particular items to installation crews) or product data submittals without a formal request submitted in accordance with Paragraph 7 or when acceptance will require substantial revision of the CONTRACT DOCUMENTS.

10. Any request for substitution received by the TOWN less than ten (10) business days from the date fixed for the opening of BIDS will not be considered.

11. If product substitution is acceptable to the TOWN, BIDDERS shall receive notification by ADDENDUM a minimum of forty-eight (48) hours prior to the BID date. If no such approval notification through ADDENDUM is received by the BIDDER, the BIDDER shall submit the original specified product.

12. If this BID is for a construction project, the provisions of Tenn. Code Ann. §§ 62-6-101 et seq., relating to General Contractors, shall be applicable and same are incorporated herein by reference. All invited BIDDERS on a construction project are advised that a BIDDER must provide evidence of a license in the appropriate classification before its BID will be considered. The Official Bid Envelope containing the BID must be plainly marked with the following information:

- a) The BIDDER'S and any electrical, plumbing, heating, ventilation, and air conditioning, and masonry (if masonry is over \$100,000) SUBCONTRACTOR's name and address;
- b) The respective Tennessee Contractor's License Numbers of the BIDDER and the aforesaid SUBCONTRACTORS and the expiration dates of each; and
- c) The part of the license classification applying to the BID for all of the foregoing.

Otherwise the BID shall not be opened or considered except that if that BID is in an amount less than \$25,000, only the name and Tennessee Contractor's License Numbers of the BIDDER for the CONTRACT and not the names and license numbers of any SUBCONTRACTORS need to appear on the outside of the envelope.

13. The TOWN has an employee drug and alcohol testing program; a copy of the relevant portions thereof is enclosed. BIDDERS must have a testing program for their employees that is at least as stringent as that of the TOWN (**Document D-1**). The enclosed DRUG AND ALCOHOL TESTING ACKNOWLEDGEMENT STATEMENT AND AFFIDAVIT (**Form D-2**) MUST BE SUBMITTED WITH THE BID. Upon request by the TOWN, the apparent low BIDDER must submit a copy or a summary of their drug and alcohol testing policy. IF BIDDERS DO NOT HAVE A TESTING PROGRAM THAT MEETS THIS REQUIREMENT, THEIR BID CANNOT BE ACCEPTED BY THE TOWN. THIS IS A REQUIREMENT OF TENNESSEE LAW AND CANNOT BE WAIVED BY THE TOWN.

14. If BIDDERS choose to do so, attach a completed voluntary Title VI and Title IX form with the BID, **Document E-2**.

15. All blank spaces for BID prices must be filled in, in ink or typewritten, and the BID form must be fully completed and executed when submitted. Only the original of the BID is required. The TOWN may, in its sole discretion, waive any informalities or defects and may reject any and all BIDS. Any BID may be withdrawn prior to the scheduled BID opening time or authorized postponements thereof. No BIDDER may withdraw its BID within sixty (60) consecutive calendar days after the actual time of the BID opening. Should there be any reason why the CONTRACT cannot be awarded within the specified time, the time may be extended by mutual agreement between the TOWN and the successful BIDDER.

16. All CONTRACT DOCUMENTS are part of the CONTRACT AND AGREEMENT (sometimes referred to as the "C&A"). A BIDDER should only execute the BID, BID BOND, Certified or Cashier's check, or Letter of Credit, DRUG AND ALCOHOL ACKNOWLEDGEMENT STATEMENT AND AFFIDAVIT (**Form D-2**), and (as applicable) ADDENDA ACKNOWLEDGEMENT FORM (**Form F (A-1)**) when making a BID. The remaining Document forms in the BID PACKET should not be executed at the time of making a BID, as they are the Document forms which either (i) contain information for the successful BIDDER or (ii) are Document forms the successful BIDDER will be required to execute and with which the successful BIDDER must comply. The BIDDER'S attention is directed to these Document forms.

17. The CONTRACT DOCUMENTS contain all the provisions required for the construction of the PROJECT. Information obtained from any officer, agent or employee of the TOWN or any other person shall not affect the risks or obligations assumed by the BIDDER or relieve the BIDDER from fulfilling any of the conditions of the C&A or the other CONTRACT DOCUMENTS.

18. BIDDERS must satisfy themselves of the accuracy of the estimated quantities in the BID SCHEDULE and other matters that shall be applicable by examination of the site and a review of the CONTRACT DOCUMENTS, including any ADDENDA. After BIDS have been submitted, a BIDDER shall not be legally entitled to assert that there was a misunderstanding concerning the quantities or conditions of the work to be performed, the quantities, qualities or conditions of the equipment and/or supplies to be furnished or any other terms or conditions of the C&A or the other CONTRACT DOCUMENTS.

19. The TOWN will consider only those BIDS that are offered by BIDDERS who can show evidence of satisfactory completion of work that is comparable in size and type to the WORK that is specified in the CONTRACT DOCUMENTS, or, in the event of a new business, satisfactory evidence of the ability to perform the work specified.

20. Instances of conflict between unit price and amount shown in the BID shall be by the unit price. The amount to be considered in the BID will be the product of the quantity shown multiplied by the unit price shown by the BIDDER.

21. The TOWN shall determine which is the lowest responsible and best BIDDER for the PROJECT and shall deliver to the successful BIDDER the C&A to be executed and returned. The successful BIDDER shall be required to return the C&A, properly executed, to the TOWN within five (5) business days after receipt of same. Upon Board of Mayor and Aldermen approval of same, the TOWN shall forward the successful BIDDER a fully executed C&A, a NOTICE OF AWARD accompanied by certain document forms, including the PAYMENT AND PERFORMANCE BONDS in the amount of 100% of the CONTRACT price to be fully executed and returned with a CERTIFICATE OF INSURANCE within fifteen (15) consecutive calendar days after receipt of same by BIDDER. Upon the TOWN's receipt and acceptance of the fully executed PAYMENT AND PERFORMANCE BONDS and CERTIFICATE OF INSURANCE COVERAGE and any other required documents, a NOTICE TO PROCEED letter will be issued by the TOWN.

22. Once the TOWN determines which party is the successful BIDDER, that BIDDER must, as indicated above, fully comply with the BID and execute and timely deliver to the TOWN the C&A and other required documents. Upon its failure to timely do so, the TOWN shall be authorized to advise the BIDDER that it is in default and that the TOWN shall proceed to contract with another to fulfill the CONTRACT with which the defaulting BIDDER has failed to comply; and the defaulting BIDDER and the SURETY on its BID BOND shall be liable for all damages suffered by the TOWN due to such default. The obligation of the defaulting BIDDER shall not be limited to the amount of its BID BOND, although the liability of the SURETY on such BID BOND will be limited to the amount thereof.

23. Any protest concerning the award of this BID shall be decided by the DIRECTOR OF GENERAL SERVICES. Protest shall be made in writing to the Office of Procurement and shall be filed within ten (10) business days of issuance of the CONTRACT award. A protest is considered filed when received by the Office of Procurement. The written protest shall include the name and address of the protestor, identification of the procurement, a statement of the specific reasons for the protest and supporting exhibits. The Office of Procurement will respond to the written protest within seven (7) business days. The DIRECTOR OF GENERAL SERVICES' decision relative to the protest shall be final.

24. The BIDDER shall be responsible for obtaining any and all permits required by the TOWN (and any other local, state, or federal agencies and/or authorities) to successfully complete this project. The TOWN will waive the costs associated with these permits, provided, however, that the BIDDER will be required to pay to the TOWN any costs associated with re-inspections by the TOWN and the BIDDER shall pay all state and federal permit fees. Applications for building, plumbing, mechanical and electrical are available at the Town of Collierville, Construction Codes Office, 500 Poplar View Parkway, Collierville, Tennessee 38017.

25. If required, the successful low apparent BIDDER shall furnish the TOWN, within forty-eight (48) hours after BIDS are received, the following detailed information for the TOWN'S use:

- a) A cost breakdown analysis of all areas of WORK contained in the BID PROPOSAL, including a separation of all labor and material items; and

- b) A list of names of SUBCONTRACTORS, other persons or organizations (including those who are to furnish materials or equipment fabricated to a special design) proposed for such portions of the WORK. The BIDDER will be required to establish, to the satisfaction of the TOWN ENGINEER and the TOWN, the reliability of the proposed SUBCONTRACTORS to furnish and perform the WORK described in the sections of the specifications pertaining to such proposed SUBCONTRACTOR's respective trades. SUBCONTRACTORS and other persons and organizations proposed by the BIDDER and accepted by the TOWN and TOWN ENGINEER must be on the WORK for which they were proposed and accepted, and shall not be changed without the written approval of the TOWN's PROJECT MANAGER or the TOWN ENGINEER.

This list shall be submitted at the time the cost breakdown analysis is presented to TOWN, as set forth in this paragraph 24.

26. The TOWN may, in its discretion, conduct a pre-BID conference in the TOWN on the date and at the time and place to be selected by the TOWN. Any party interested in bidding should so advise the TOWN in writing by faxing or e-mailing notice of such interest to the TOWN'S DIRECTOR OF GENERAL SERVICES at fax number 901-457-2258 or by email to tocpurchasing@colliervilletn.gov. That party will receive notice of the date, time and place of the pre-BID conference. BIDDERS are strongly encouraged to attend this conference and to submit written questions in advance of the conference to the TOWN's Procurement Specialist. Additional written questions may be submitted at the conference. Attendance at the pre-BID conference is not a pre-requisite for submission of a BID. If the TOWN has set a pre-BID conference, the conference shall be held on the date at the time and place set forth herein below.

PRE-BID CONFERENCE TO BE HELD:

DATE: Wednesday, August 7, 2024

TIME: 08:30:00 AM

LOCATION: SHELTON RD. WWTP TREATMENT PLANT
136 East Shelton Rd.
Collierville, TN 38017

TOWN OF COLLIERVILLE DRUG AND ALCOHOL TESTING POLICY

All Town of Collierville employees are subject to reasonable suspicion drug and alcohol testing. Employees in safety-sensitive positions, including, without limitation, police, fire and those who hold a commercial driver's license, are subject to pre-employment, reasonable suspicion, post-accident and random drug and alcohol testing. Upon request by the TOWN, the apparent low BIDDER will be required to submit a copy or a summary of their drug and alcohol testing policy. BIDDERS are hereby notified pursuant to Tenn. Code Ann. § 50-9-114 that employers shall have seven (7) calendar days from the date that the successful BIDDER and the TOWN enter into the C&A to file suit in the Shelby County Chancery Court to contest the C&A on the grounds that it violates said statute. Employers that do not contest the C&A within said seven (7) calendar days by filing suit in Shelby County Chancery Court shall waive their rights to challenge the C&A for violation of the provisions of Tenn. Code Ann. § 50-9-114.

DRUG AND ALCOHOL TESTING ACKNOWLEDGMENT STATEMENT AND AFFIDAVIT

Comes _____, for and on behalf of
(Printed name of Principal Officer of Company)
_____, (the "Company") and, after being duly authorized by the Company so to do, makes oath that: (i) the Company has received a copy of the relevant portions of the Town of Collierville Drug and Alcohol Testing Policy; (ii) the Company understands that it must have a drug and alcohol testing policy at least as stringent as that of the Town of Collierville; and (iii) the Company has in effect a drug and alcohol testing policy at least as stringent as that of the Town of Collierville.

Upon request, a summary of the relevant portions of the Company's drug and alcohol testing program or a complete copy thereof will be provided.

Signature

Title: _____

Sworn to and subscribed before me, a Notary Public, this _____ day of _____, 20__.

Notary Public

My Commission Expires:

TITLE VI INFORMATION

1. The Town of Collierville agrees to comply with the Title VI of the Civil Rights Act of 1964 (42 U.S.C. § 2000d, et seq.), and the Department of Transportation Implementing Regulations (49 CFR Part 21) relative to the CONTRACT which is the subject hereof.
2. The CONTRACTOR is requested, but is not obligated, to include the attached disclosure sheet, Voluntary Title VI and Title IX Form, with the CONTRACTOR's sealed BID.

VOLUNTARY TITLE VI AND TITLE IX FORM

Attach form to sealed BID

For Title VI and Title IX compliance, the CONTRACTOR's voluntary disclosure of the following information is requested.

1. Number of CONTRACTOR's Employees Who Are:

_____ Male _____ Female

2. Number of CONTRACTOR's Employees Who Are:

_____ Caucasian _____ African American

_____ Other (please specify) _____

BID

BID of:

(Name of BIDDER)

****REQUIRED TO SUBMIT BID: TOWN OF COLLIERVILLE VENDOR # _____**

organized and existing under the laws of the State of _____ and doing business as _____ (indicate: “a corporation”, “a partnership”, “an individual”, a “limited liability company” or otherwise, as applicable).

To: Town of Collierville - Owner
Director of General Services
500 Poplar View Parkway
Collierville, Tennessee 38017

In compliance with the TOWN’s ADVERTISEMENT FOR BIDS, BIDDER hereby proposes to furnish all necessary labor, machinery, tools, apparatus, materials, equipment, services, and other necessary supplies in strict accordance with the terms and conditions of the plans, specifications and CONTRACT DOCUMENTS within the number of consecutive calendar days and at the prices set forth below for the construction of:

Project: TC2024-42 RE-BID SHELTON RD. WWTP OXIDATION DITCH ROTOR REPLACEMENT

By submitting this BID, BIDDER certifies that this BID has been arrived at independently without consultation, communication or agreement as to any matter relating to this BID with any other BIDDER or with any other competitor.

BIDDER agrees, upon receipt of notice of successful bidder status from the TOWN to comply with the procedures as set forth on Pages “H-1 through H-3” of INFORMATION FOR SUCCESSFUL BIDDERS. BIDDER further agrees, upon receipt of the NOTICE TO PROCEED, (i) to commence work on the PROJECT not later than the last date stated in the NOTICE TO PROCEED as to which the BIDDER may commence to proceed, (ii) to achieve Substantial Completion of the PROJECT within thirty (30) consecutive calendar days after such date, otherwise, to pay the TOWN as liquidated damages the sum of two hundred fifty dollars (\$250.00) for each consecutive calendar day thereafter as provided in the GENERAL PROVISIONS; and (iii) to complete all Punch List items within ten (10) consecutive calendar days after the date of Substantial Completion, as such date is determined by the TOWN, in its sole discretion, otherwise, the BIDDER agrees that the TOWN may use any remaining retainage to complete all Punch List items. Because it would be difficult and/or impossible to determine the resulting costs/damages to the TOWN, said liquidated damages amount is stipulated and agreed, under the circumstances, to be a fair and reasonable estimate of TOWN’s potential damages at the time the parties have entered into the CONTRACT, and shall not be construed or otherwise considered to be a penalty.

BIDDER acknowledges receipt of addenda(s) No. _____.

By submission of this bid, each BIDDER and each person signing on behalf of any BIDDER certifies, and in the case of a joint bid each party thereto certifies as to its own organization, under penalty of perjury, that to the best of its knowledge and belief that each BIDDER is not on the list created pursuant to § 12-12-106. This list is generated to identify entities ineligible to contract with the State of Tennessee or any political subdivision of the State per the Iran Divestment Act, T.C.A. § 12-12-101 et seq., and the current list may be found at the Tennessee Department of General Services, Central Procurement Office, website under the Public Information Library webpage.

Concerning the Non-Boycott of Israel Act (TCA 12-4-1 et seq.), by submission of this bid/quote/proposal, each supplier and each person signing on behalf of any supplier certifies, and in the case of a joint bid/quote/proposal, each party thereto certifies as to its own organization, under penalty of perjury, that to the best of its knowledge and belief that each supplier is not boycotting Israel pursuant to § 12-4-1 and will not during the term of any award. Note: Applicable only to contracts of \$250,000 or more and to suppliers with 10 or more employees.

BIDDER agrees to perform all work described in the CONTRACT DOCUMENTS for the following unit price or lump sum:

BID FORM

Item	Description	Unit	Quantity	Total Price
1	Supply all materials & labor for the direct replacement of (2) two oxidation ditch rotors at Shelton Rd. WWTP as per TC2024-42 specifications.	Lump Sum	1	
Total Bid:				

TOTAL BID PRICE, IN WORDS:

_____ DOLLARS AND _____ CENTS (\$ _____ . _____)

Estimated Lead time for Materials: _____

Bidder must complete Table for New Rotor Efficiency Curves (as per specification 4.1)

SPEED (rev/min)	SUBMERGENCE	LBS/O2/HR/FT	HP/FT
	6"		
	8"		
	10"		
	12"		

**Bidder must Attach Certification of Compliance (Pages F3-F9)
&
Documentation of Entity Status (SAM.gov Screenshot – Page F-10)**

SIGNATURES ON FOLLOWING PAGE

Submitted By:

Name of BIDDER (Company Name)

Signature: _____

Printed Name: _____

Title: _____

Address: _____

Phone: _____

Fax: _____

Email: _____

(Date BID Submitted)

License Number

Date of Expiration of License

TC2024-42 Reference Information:

Reference 1:

Entity or Utility Name
Address
Point of Contact Name
Point of Contact Email
Point of Contact Phone Number
Type of Application
Product Name (Manufacturer)
Product Model

Reference 6:

Entity or Utility Name
Address
Point of Contact Name
Point of Contact Email
Point of Contact Phone Number
Type of Application
Product Name (Manufacturer)
Product Model

Reference 2:

Entity or Utility Name
Address
Point of Contact Name
Point of Contact Email
Point of Contact Phone Number
Type of Application
Product Name (Manufacturer)
Product Model

Reference 7:

Entity or Utility Name
Address
Point of Contact Name
Point of Contact Email
Point of Contact Phone Number
Type of Application
Product Name (Manufacturer)
Product Model

Reference 3:

Entity or Utility Name
Address
Point of Contact Name
Point of Contact Email
Point of Contact Phone Number
Type of Application
Product Name (Manufacturer)
Product Model

Reference 8:

Entity or Utility Name
Address
Point of Contact Name
Point of Contact Email
Point of Contact Phone Number
Type of Application
Product Name (Manufacturer)
Product Model

Reference 4:

Entity or Utility Name
Address
Point of Contact Name
Point of Contact Email
Point of Contact Phone Number
Type of Application
Product Name (Manufacturer)
Product Model

Reference 9:

Entity or Utility Name
Address
Point of Contact Name
Point of Contact Email
Point of Contact Phone Number
Type of Application
Product Name (Manufacturer)
Product Model

Reference 5:

Entity or Utility Name
Address
Point of Contact Name
Point of Contact Email
Point of Contact Phone Number
Type of Application
Product Name (Manufacturer)
Product Model

Reference 10:

Entity or Utility Name
Address
Point of Contact Name
Point of Contact Email
Point of Contact Phone Number
Type of Application
Product Name (Manufacturer)
Product Model

CERTIFICATION OF COMPLIANCE

RETURN THIS PAGE WITH BID RESPONSE FORM

Proposer Name: _____

By indication of the authorized signature below, the Proposer does hereby make certification and assurance of the Proposer's compliance with:

1. **the laws of the State of Tennessee.**
2. **Title VI of the Civil Rights Act of 1964.**
3. **Equal Employment Opportunity.**

Any contract that uses federal funds to pay for construction work is a "federally assisted construction contract" and must include the equal opportunity clause found in 2 C.F.R. Part 200, unless otherwise stated in 41 C.F.R. Part 60. This contract provision is required for all procurements that meet the definition of a "federally assisted construction contract." Required Language. The regulation at 41 C.F.R. Part 60-1.4(b) requires the insertion of the following contract clause. During the performance of this contract, the contractor agrees as follows: (1) The contractor will not discriminate against any employee or applicant for employment because of race, color, religion, sex, sexual orientation, gender identity, or national origin. The contractor will take affirmative action to ensure that applicants are employed, and that employees are treated during employment without regard to their race, color, religion, sex, sexual orientation, gender identity, or national origin. Such action shall include, but not be limited to the following: Employment, upgrading, demotion, or transfer; recruitment or recruitment advertising; layoff or termination; rates of pay or other forms of compensation; and selection for training, including apprenticeship. The contractor agrees to post in conspicuous places, available to employees and applicants for employment, notices to be provided setting forth the provisions of this nondiscrimination clause. (2) The contractor will, in all solicitations or advertisements for employees placed by or on behalf of the contractor, state that all qualified applicants will receive consideration for employment without regard to race, color, religion, sex, sexual orientation, gender identity, or national origin. (2) The contractor will not discharge or in any other manner discriminate against any employee or applicant for employment because such employee or applicant has inquired about, discussed, or disclosed the compensation of the employee or applicant or another employee or applicant. This provision shall not apply to instances in which an employee who has access to the compensation information of other employees or applicants as a part of such employee's essential job functions discloses the compensation of such other employees or applicants to individuals who do not otherwise have access to such information, unless such disclosure is in response to a formal complaint or charge, in furtherance of an investigation, proceeding, hearing, or action, including an investigation conducted by the employer, or is consistent with the contractor's legal duty to furnish information. (3) The contractor will send to each labor

union or representative of workers with which he has a collective bargaining agreement or other contract or understanding, a notice to be provided advising the said labor union or workers' representatives of the contractor's commitments under this section and shall post copies of the notice in conspicuous places available to employees and applicants for employment. (4) The contractor will comply with all provisions of Executive Order 11246 of September 24, 1965, and of the rules, regulations, and relevant orders of the Secretary of Labor. (5) The contractor will furnish all information and reports required by Executive Order 11246 of September 24, 1965, and by rules, regulations, and orders of the Secretary of Labor, or pursuant thereto, and will permit access to his books, records, and accounts by the administering agency and the Secretary of Labor for purposes of investigation to ascertain compliance with such rules, regulations, and orders. (6) In the event of the contractor's noncompliance with the nondiscrimination clauses of this contract or with any of the said rules, regulations, or orders, this contract may be canceled, terminated, or suspended in whole or in part and the contractor may be declared ineligible for further Government contracts or federally assisted construction contracts in accordance with procedures authorized in Executive Order 11246 of September 24, 1965, and such other sanctions may be imposed and remedies invoked as provided in Executive Order 11246 of September 24, 1965, or by rule, regulation, or order of the Secretary of Labor, or as otherwise provided by law. (8) The contractor will include the portion of the sentence immediately preceding paragraph (1) and the provisions of paragraphs (1) through (7) in every subcontract or purchase order unless exempted by rules, regulations, or orders of the Secretary of Labor issued pursuant to section 204 of Executive Order 11246 of September 24, 1965, so that such provisions will be binding upon each subcontractor or vendor. The contractor will take such action with respect to any subcontract or purchase order as the administering agency may direct as a means of enforcing such provisions, including sanctions for noncompliance: Provided, however, that in the event a contractor becomes involved in, or is threatened with, litigation with a subcontractor or vendor as a result of such direction by the administering agency, the contractor may request the United States to enter into such litigation to protect the interests of the United States. The applicant further agrees that it will be bound by the above equal opportunity clause with respect to its own employment practices when it participates in federally assisted construction work: Provided, That if the applicant so participating is a State or local government, the above equal opportunity clause is not applicable to any agency, instrumentality or subdivision of such government which does not participate in work on or under the contract. The applicant agrees that it will assist and cooperate actively with the administering agency and the Secretary of Labor in obtaining the compliance of contractors and subcontractors with the equal opportunity clause and the rules, regulations, and relevant orders of the Secretary of Labor, that it will furnish the administering agency and the Secretary of Labor such information as they may require for the supervision of such compliance, and that it will otherwise assist the administering agency in the discharge of the agency's primary responsibility for securing compliance. The applicant further agrees that it will refrain from entering into any contract or contract modification subject to Executive Order 11246 of September 24, 1965, with a contractor debarred from, or who has not demonstrated eligibility for, Government contracts and federally assisted construction contracts pursuant to the Executive Order and will

carry out such sanctions and penalties for violation of the equal opportunity clause as may be imposed upon contractors and subcontractors by the administering agency or the Secretary of Labor pursuant to Part II, Subpart D of the Executive Order. In addition, the applicant agrees that if it fails or refuses to comply with these undertakings, the administering agency may take any or all of the following actions: Cancel, terminate, or suspend in whole or in part this grant (contract, loan, insurance, guarantee); refrain from extending any further assistance to the applicant under the program with respect to which the failure or refund occurred until satisfactory assurance of future compliance has been received from such applicant; and refer the case to the Department of Justice for appropriate legal proceedings.

4. **the Iran Divestment Act** of 2016 and each person signing on behalf of any BIDDER certifies, and in the case of a joint bid each party thereto certifies as to its own organization, under penalty of perjury, that to the best of its knowledge and belief that each BIDDER is not on the list created pursuant to § 12-12-106 generated to identify entities ineligible to contract with the State of Tennessee or any political subdivision of the State per the Iran Divestment Act, T.C.A. § 12-12-101 et seq., and the current list may be found at the Tennessee Department of General Services, Central Procurement Office, website under the Public Information Library webpage;
5. **the Non-Boycott of Israel Act** (TCA 12-4-1 et seq.), by submission of this bid/quote/proposal, each supplier and each person signing on behalf of any supplier certifies, and in the case of a joint bid/quote/proposal, each party thereto certifies as to its own organization, under penalty of perjury, that to the best of its knowledge and belief that each supplier is not boycotting Israel pursuant to § 12-4-1 and will not during the term of any award. Note: Applicable only to contracts of \$250,000 or more and to suppliers with 10 or more employees.
6. **Copeland Anti-Kickback Act**
 - a. Contractor. The contractor shall comply with 18 U.S.C. § 874, 40 U.S.C. § 3145, and the requirements of 29 C.F.R. pt. 3 as may be applicable, which are incorporated by reference into this contract.
 - b. Subcontracts. The contractor or subcontractor shall insert in any subcontracts the clause above and a clause requiring the subcontractors to include these clauses in any lower tier subcontracts. The prime contractor shall be responsible for the compliance by any subcontractor or lower tier subcontractor with all of these contract clauses.
 - c. Breach. A breach of the contract clauses above may be grounds for termination of the contract, and for debarment as a contractor and subcontractor as provided in 29 C.F.R. § 5.12.”
7. **Contract Work Hours and Safety Standards Act**
 - (1) Overtime requirements. No contractor or subcontractor contracting for any part of the contract work which may require or involve the employment of laborers or mechanics shall require or permit any such laborer or mechanic in any workweek in which he or she is employed on such work to work in excess of forty hours in such workweek unless such laborer or mechanic receives compensation at a rate not less than one and one-half times the basic rate of pay for all hours worked in excess of forty hours in such workweek.
 - (2) Violation; liability for unpaid wages; liquidated damages. In the event of any violation of the clause set forth in paragraph (b)(1) of this section the contractor and any subcontractor responsible therefore shall

be liable for the unpaid wages. In addition, such contractor and subcontractor shall be liable to the United States (in the case of work done under contract for the District of Columbia or a territory, to such District or to such territory), for liquidated damages. Such liquidated damages shall be computed with respect to each individual laborer or mechanic, including watchmen and guards, employed in violation of the clause set forth in paragraph (b)(1) of this section, in the t \$27 for each calendar day on which such individual was required or permitted to work in excess of the standard workweek of forty hours without payment of the overtime wages required by the clause set forth in paragraph (b)(1) of this section.

(3) Withholding for unpaid wages and liquidated damages. The (write in the name of the Federal agency or the loan or grant recipient) shall upon its own action or upon written request of an authorized representative of the Department of Labor withhold or cause to be withheld, from any moneys payable on account of work performed by the contractor or subcontractor under any such contract or any other Federal contract with the same prime contractor, or any other federally assisted contract subject to the Contract Work Hours and Safety Standards Act, which is held by the same prime contractor, such sums as may be determined to be necessary to satisfy any liabilities of such contractor or subcontractor for unpaid wages and liquidated damages as provided in the clause set forth in paragraph (b)(2) of this section.

(4) Subcontracts. The contractor or subcontractor shall insert in any subcontracts the clauses set forth in paragraph (b)(1) through (4) of this section and also a clause requiring the subcontractors to include these clauses in any lower tier subcontracts. The prime contractor shall be responsible for compliance by any subcontractor or lower tier subcontractor with the clauses set forth in paragraphs (b)(1) through (4) of this section.

8. Clean Air Act

(1) The contractor agrees to comply with all applicable standards, orders or regulations issued pursuant to the Clean Air Act, as amended, 42 U.S.C. § 7401 et seq

(2) The contractor agrees to report each violation to the (name of subrecipient entering into the contract) and understands and agrees that the (name of the subrecipient entering into the contract) will, in turn, report each violation as required to assure notification to Treasury, and the appropriate Environmental Protection Agency Regional Office.

(3) The contractor agrees to include these requirements in each subcontract exceeding \$150,000.

9. Federal Water Pollution Control Act

(1) The contractor agrees to comply with all applicable standards, orders, or regulations issued pursuant to the Federal Water Pollution Control Act, as amended, 33 U.S.C. 1251 ets eq.

(2) The contractor agrees to report each violation to the (name of the subrecipient entering into the contract) and understands and agrees that the (name of the subrecipient entering into the contract) will, in turn, report each violation as required to assure notification to the Treasury, and the appropriate Environmental Protection Agency Regional Office.

(3) The contractor agrees to include these requirements in each subcontract exceeding \$150,000.

10. Suspension and Debarment

(1) This contract is a covered transaction for the purposes of 2 C.F.R. pt. 180 and 2 C.F.R. pt. 3000. As such, the contractor is required to verify that none of the contractor's principals (defined at 2 C.F.R. § 180.995) or its affiliates (defined at 2 C.F.R. § 180.905) are excluded (defined at 2 C.F.R. § 180.940) or disqualified (defined at 2 C.F.R. § 180.935).

(2) The contractor must comply with 2 C.F.R. pt. 180, subpart C and 2 C.F.R. pt. 3000, subpart C, and must include a requirement to comply with these regulations in any lower tier covered transaction it enters into.

(3) This certification is a material representation of fact relied upon by the Town of Collierville. If it is later determined that the contractor did not comply with 2 C.F.R. pt. 180, subpart C and 2 C.F.R. pt. 3000, subpart C, in addition to remedies available to (insert name of recipient/subrecipient/applicant), the Federal Government may pursue available remedies, including but not limited to suspension and/or debarment.

(4) The bidder or proposer agrees to comply with the requirements of 2 C.F.R. pt. 180, subpart C and 2 C.F.R. pt. 3000, subpart C while this offer is valid and throughout the period of any contract that may arise from this offer. The bidder or proposer further agrees to include a provision requiring such compliance in its lower tier covered transactions.

11. Byrd Anti-Lobbying Amendment, 31 U.S.C § 1352 (as amended).

Contractors who apply or bid for an award of \$100,000 or more shall file the required Certification Regarding Lobbying. Each tier certifies to the tier above that it will not and has not used Federal appropriated funds to pay any person or organization for influencing or attempting to influence an officer or employee of any agency, a Member of Congress, officer or employee of Congress, or an employee of a Member of Congress in connection with obtaining any Federal contract, grant, or any other award covered by 31 U.S.C. § 1352. Each tier shall also disclose any lobbying with non-Federal funds that takes place in connection with obtaining any Federal award. Such disclosures are forwarded from tier to tier up to the recipient who in turn will forward the certification(s) to the awarding agency.

12. Procurement of Recovered Materials

In the performance of this contract, the Contractor shall make maximum use of products containing recovered materials that are EPA-designated items unless the product cannot be acquired competitively within a timeframe providing for compliance with the contract performance schedule; meeting contract performance requirements; or at a reasonable price. Information about this requirement, along with the list of EPA-designated items, is available at EPA's Comprehensive Procurement Guidelines webpage. The Contractor also agrees to comply with all other applicable requirements of Section 6002 of the Solid Waste Disposal Act.

13. Domestic Preference for Procurement

As appropriate, and to the extent consistent with law, the contractor should, to the greatest extent practicable, provide a preference for the purchase, acquisition, or use of goods, products, or materials produced in the United States. This includes, but is not limited to iron, aluminum, steel, cement, and other manufactured products. For purposes of this clause: Produced in the United States means, for iron and steel products, that

all manufacturing processes, from the initial melting stage through the application of coatings, occurred in the United States. Manufactured products mean items and construction materials composed in whole or in part of non-ferrous metals such as aluminum; plastics and polymer-based products such as polyvinyl chloride pipe; aggregates such as concrete; glass, including optical fiber; and lumber.”

14. Access to Records

(1) The Contractor agrees to provide (insert name of state agency or local or Indian tribal government), (insert name of recipient), Treasury, the Comptroller General of the United States, or any of their authorized representatives access to any books, documents, papers, and records of the Contractor which are directly pertinent to this contract for the purposes of making audits, examinations, excerpts, and transcriptions.

(2) The Contractor agrees to permit any of the foregoing parties to reproduce by any means whatsoever or to copy excerpts and transcriptions as reasonably needed.

(3) The Contractor agrees to provide the Treasury or authorized representatives access to construction or other work sites pertaining to the work being completed under the contract.

15. Contract Changes or Modifications

To be eligible for ARP SLFRF assistance under the non-Federal entity’s Treasury grant or cooperative agreement, the cost of the change, modification, change order, or constructive change must be allowable, allocable, within the scope of its grant or cooperative agreement, and reasonable for the completion of project scope.

16. Compliance with Federal Law, Regulations and Executive Orders

This is an acknowledgement that Treasury ARP SLFRF financial assistance will be used to fund all or a portion of the contract. The contractor will comply with all applicable Federal law, regulations, executive orders, Treasury policies, procedures, and directives.

17. Program Fraud and False or Fraudulent Statements or Related Acts

The Contractor acknowledges that 31 U.S.C. Chap. 38 (Administrative Remedies for False Claims and Statements) applies to the Contractor’s actions pertaining to this contract.

18. Prohibition on certain telecommunications and video surveillance services or equipment

Recipients and subrecipients are prohibited from obligating or expending loan or grant funds to:

- 1) Procure or obtain.
- 2) Extend or renew a contract to procure or obtain; or
- 3) Enter into a contract (or extend or renew a contract) to procure or obtain equipment, services, or systems that uses covered telecommunications equipment or services as a substantial or essential component of any system, or as critical technology as part of any system. As described in Public Law 115-232, section 889, covered telecommunications equipment is telecommunications equipment produced by Huawei Technologies Company or ZTE Corporation (or any subsidiary or affiliate of such entities).

- a) For the purpose of public safety, security of government facilities, physical security surveillance of critical infrastructure, and other national security purposes, video surveillance and telecommunications equipment produced by Hytera Communications Corporation, Hangzhou

Hikvision Digital Technology Company, or Dahua Technology Company (or any subsidiary or affiliate of such entities).

b) Telecommunications or video surveillance services provided by such entities or using such equipment.

c) Telecommunications or video surveillance equipment or services produced or provided by an entity that the Secretary of Defense, in consultation with the Director of the National Intelligence or the Director of the Federal Bureau of Investigation, reasonably believes to be an entity owned or controlled by, or otherwise connected to, the government of a covered foreign country.

In implementing the prohibition under Public Law 115-232, section 889, subsection (f), paragraph (1), heads of executive agencies administering loan, grant, or subsidy programs shall prioritize available funding and technical support to assist affected businesses, institutions and organizations as is reasonably necessary for those affected entities to transition from covered communications equipment and services, to procure replacement equipment and services, and to ensure that communications service to users and customers is sustained.

19. the condition that the submitted proposal was independently arrived at, without collusion, under penalty of perjury.
20. the condition that no amount shall be paid directly or indirectly to an employee or official of the Town of Collierville as wages, compensation, or gifts in exchange for acting as an officer, agent, employee, subcontractor, or consultant to the Proposer in connection with the procurement under this RFSOQ.

The Contractor certifies or affirms the truthfulness and accuracy of each statement of its certification and disclosure, if any. In addition, the Contractor understands and agrees that the provisions of 31 U.S.C.Chap. 38, Administrative Remedies for False Claims and Statements, apply to this certification and disclosure, if any

Proposer Signature and Date

**DOCUMENTATION
OF
ENTITY STATUS**

(Attach SAM.gov Status Screenshot)

**Certification Regarding Debarment, Suspension, and Other
Responsibility Matters**

_____ certifies to the best of its knowledge and
belief, that it
(Organization)

and its principals:

- (a) Are not presently debarred, suspended, proposed for debarment, declared ineligible, or voluntarily excluded by any Federal department or agency;
- (b) Have not within a three-year period preceding this bid been convicted of or had a civil judgement rendered against them for commission of fraud or criminal offense in connection with obtaining, attempting to obtain, or performing a public (Federal, State or Local) transaction or contract under a public transaction, violation of Federal or State antitrust statues or commission of embezzlement, theft, forgery, bribery, falsification or destruction of records, making false statements or receiving stolen property;
- (c) Have not within three-year period preceding this bid had one or more public transaction (Federal, State, or local) terminated for cause or default.

**RETURN THIS PAGE WITH BID RESPONSE
FORM**

Signature and Date

Printed Name

Printed Name

Organization

ADDENDA ACKNOWLEDGEMENT FORM

BIDDER acknowledges receipt of the following ADDENDA (as applicable):

ADDENDUM No. 1 _____ Dated _____
ADDENDUM No. 2 _____ Dated _____
ADDENDUM No. 3 _____ Dated _____
ADDENDUM No. 4 _____ Dated _____
ADDENDUM No. 5 _____ Dated _____
ADDENDUM No. 6 _____ Dated _____
ADDENDUM No. 7 _____ Dated _____
ADDENDUM No. 8 _____ Dated _____
ADDENDUM No. 9 _____ Dated _____
ADDENDUM No. 10 _____ Dated _____

(Name of BIDDER)

By: _____

Title: _____

Use this form for BID BOND.

BID BOND

KNOW ALL MEN BY THESE PRESENTS, that we, the undersigned, _____ (BIDDER) and _____ (SURETY) are held and firmly bound unto the TOWN OF COLLIERVILLE, TENNESSEE in the penal sum of five percent (5%) of the total amount of the BID, for the payment of which, well and truly to be made, we hereby jointly and severally bind ourselves, our heirs, executors, administrators, successors and assigns, firmly by these presents.

The conditions of the above obligation are such that whereas BIDDER has submitted to the TOWN a certain BID, attached hereto and hereby made a part hereof, to execute and enter into a certain CONTRACT AND AGREEMENT (C&A) for the construction of TC2024-42 RE-BID SHELTON RD. WWTP OXIDATION DITCH ROTOR REPLACEMENT in compliance with the CONTRACT DOCUMENTS.

NOW, THEREFORE,

- (a) If the BID shall be rejected, or
- (b) If the BID is accepted and the BIDDER enters into a C&A for said project with the TOWN OF COLLIERVILLE within fifteen (15) consecutive calendar days after receipt of the NOTICE OF AWARD accompanied by the C&A and all required attachments, then, this obligation shall be null and void; otherwise the same shall remain in full force and effect; it being expressly understood and agreed that the liability of the SURETY for any and all claims hereunder shall, in no event, exceed the penal sum of this obligation as herein stated but the liability of the BIDDER is not so limited.

The SURETY, for value received, hereby stipulates and agrees that the obligation of said SURETY on this, its BID BOND, shall in no way be impaired or released by any extension of the time within which the TOWN may accept such BID and the SURETY does hereby waive notice of any such extension.

WITNESS THE DUE EXECUTION HEREOF, on the _____ day of _____, 20____.

NAME OF BIDDER

BY: _____
Signature of BIDDER or Authorized Officer

Title: _____

NAME OF SURETY

BY: _____
Authorized Representative
(Attach Power of Attorney)

INFORMATION FOR SUCCESSFUL BIDDER

Those proposing to bid on the construction and completion of this TOWN Project (PROJECT) should note the following:

1. The TOWN may award the CONTRACT to the lowest responsible and best BIDDER in accordance with the CONTRACT DOCUMENTS and in accordance with the following provisions:
 - a) The TOWN may conduct such investigations as it deems necessary to evaluate any BID and to conclude, if warranted, that the BIDDER or, if an entity, its owners and officers, and the BIDDER's proposed SUBCONTRACTORS, are responsible, qualified, and competent and have the financial ability to do the WORK in accordance with the CONTRACT DOCUMENTS to the TOWN's satisfaction within the prescribed time.
 - b) The TOWN reserves the right to reject the BID of any BIDDER who does not satisfy such evaluation.
 - c) The TOWN reserves the right to reject any BID if any of the unit prices contained therein are obviously unbalanced, either above or below the reasonable cost thereof, as analyzed by the TOWN. The purpose of insisting on balanced unit prices is to prevent the TOWN from paying excessive unit prices, even though the BID, as a whole, is the lowest BID.
 - d) The TOWN reserves the right to: reject any and all BIDS; waive any and all informalities; and discard all nonconforming and non-responsive or conditional BIDS.
 - e) In evaluating BIDS, the TOWN shall consider the qualifications of the BIDDERS, the degree of compliance with the prescribed requirements, and the alternatives and unit prices (if requested in the BID forms).
 - f) As a part of the evaluation process, the lowest apparent responsible and best BIDDER may be required to provide a detailed description of their Safety Program including the name of the BIDDER'S Safety Officer, CONTRACT information and location at which they maintain their office. The BIDDER will also be required to provide a list of any citations received for willful violations for failure to abate or for repeated violations by the United States Occupational Safety and Health Administration (OSHA); by the Tennessee Occupational Safety and Health Administration (TOSHA); or by any other governmental body for the previous three (3) years. Violations should be noted along with the nature of the violation, date of the violation, and name, address, telephone number and contact person for the agency issuing the citation.
 - g) If awarded, the CONTRACT will be awarded to the lowest BIDDER whose evaluation by the TOWN indicates that the award will be in the best interest of the PROJECT.
 - h) The TOWN may reject all BIDS submitted and call for new BIDS.
2. The TOWN will notify the successful BIDDER that it is the successful BIDDER following evaluation. The TOWN will then notify the successful BIDDER

(referred to as “CONTRACTOR”) that the C&A document is ready for execution and will email a copy of the same to CONTRACTOR. CONTRACTOR shall then be responsible for returning same to the TOWN, properly signed and executed, within five (5) business days of receipt.

3. The CONTRACTOR shall be notified by the TOWN when said C&A, with the required attachments, has been approved and executed on behalf of the TOWN and the TOWN shall furnish a copy of the same to the CONTRACTOR. The TOWN will thereafter issue in writing to the CONTRACTOR a NOTICE OF AWARD accompanied by the PAYMENT AND PERFORMANCE BONDS and information regarding the TOWN’S insurance requirements and pre-construction meeting requirements. Said PAYMENT AND PERFORMANCE BONDS and CERTIFICATE OF INSURANCE (ACORD form or other approved industry standard form) must be attached to the C&A and returned to the TOWN within fifteen (15) consecutive calendar days after receipt of same by CONTRACTOR. The CONTRACTOR is required to sign the PAYMENT AND PERFORMANCE BONDS exactly as set out therein, have an authorized agent of an insurance company authorized to do business in the State of Tennessee sign same and attach his Power of Attorney. PAYMENT AND PERFORMANCE BONDS must be considered good and solvent by the TOWN, must be in the amount of 100% of the CONTRACT price, and must remain in the amount of 100% of the CONTRACT price, including any amendment thereto, for the duration of the PROJECT. A good and solvent bond means a bond (1) written by SURETY company listed on the United States Department of the Treasury Financial Management Service (FMS) list of approved bonding companies, (2) written for an amount which is less than or equal to the amount indicated as approved for the SURETY or insurance company by the FMS, and (3) is written by a SURETY or insurance company that is licensed and authorized to do business as a SURETY or insurer in the State of Tennessee. The CONTRACTOR is required to have an authorized agent of an insurance company or companies authorized to do business in the State of Tennessee sign a CERTIFICATE OF INSURANCE.
4. Following receipt and acceptance of PAYMENT AND PERFORMANCE BONDS, CERTIFICATE OF INSURANCE and other required documents indicated in the NOTICE OF AWARD, the TOWN will thereafter notify the CONTRACTOR to commence work under the C&A as instructed in the “Notice to Proceed” letter. When such occurs, the CONTRACTOR is required to commence work on the PROJECT as specified therein and complete construction of the PROJECT within the number of consecutive calendar days set out in the CONTRACT DOCUMENTS
5. If the CONTRACTOR fails to comply with the foregoing, he shall become liable to the TOWN for any damages, including liquidated damages, suffered by the TOWN because of such failure and/or may lose any benefits obtained by receiving the NOTICE OF AWARD.

6. Further, the CONTRACTOR, by submitting his BID, agrees that he has read and is familiar with all the terms and conditions of the documents making up the CONTRACT DOCUMENTS and will abide by the terms and conditions thereof.
7. The C&A and the other CONTRACT DOCUMENTS will be interpreted in accordance with and controlled by the laws of the State of Tennessee.
8. Instances of conflict between unit price and amount shown in the BID shall be by the unit price. The amount to be considered in the BID will be the product of the quantity shown multiplied by the unit price shown by the BIDDER.
9. The original of the C&A shall remain on file at the Office of the DIRECTOR OF GENERAL SERVICES, 500 Poplar View Parkway, Collierville, Tennessee 38017. Drawings and Specifications shall remain on file at the office set out in the CONTRACT DOCUMENTS.

**CONTRACT AND AGREEMENT BY AND BETWEEN
THE TOWN OF COLLIERVILLE, TENNESSEE
AND
CONTRACTORS NAME**

This CONTRACT AND AGREEMENT (sometimes “C&A”) is entered into this ____ day of _____, 20____, by and between the TOWN OF COLLIERVILLE, TENNESSEE, a municipality organized and existing under the laws of the State of Tennessee (“TOWN”), and _____, a _____ *[State Where CONTRACTOR Established]* _____ *[type of entity, e.g., corporation, LLC, partnership]* (“CONTRACTOR”). For and in consideration of the agreements, covenants, payments and promises herein, the receipt and sufficiency of which consideration is hereby acknowledged, the TOWN and CONTRACTOR contract, covenant and agree as follows:

ARTICLE I

One (1) set of complete CONTRACT DOCUMENTS is on file in the Office of the DIRECTOR OF GENERAL SERVICES. The parties expressly agree that the following documents are a part of this C&A:

Advertisement for Bids	A
Special Notice	B
Information for Bidders	C-1 thru C-7
Drug and Alcohol Testing Policy	D-1 thru D-2
Title VI Information	E-1 thru E-2
Bid Form	F-1 thru F-4
Certification of Compliance	F-5 thru F-11
Documentation of Entity Status (Sam.gov Status)	F-12
Addenda Acknowledgement Form	F(A-1)
Bid Bond	G
Information for Successful Bidder	H-1 thru H-3
Contract and Agreement	I-1 thru I-9
Payment Bond	J-1 thru J-3
Performance Bond	K-1 thru K-3
Collierville Insurance Requirement	L-1 thru L-5
Certificate of Payment to Contractor	M-1 thru M-2
Notice of Award	N
Notice to Proceed	O
Notice of Project Acceptance	P
Change Order Form	Q
General Provisions	GP-1 thru GP-31
Special Conditions	SC-1 thru SC-1

SPECIFICATIONS

Shelton Road Wastewater Treatment Plant Oxidation
Ditch Rotor Replacement Scope And Specifications

Page 1 - 5

CONSTRUCTION DRAWINGS/ATTACHMENTS

Attachment A.	Original Rotor Bid Specifications
Attachment B.	Project Site Location
Attachment C.	Oxidation Ditch #1
Attachment D.	Oxidation Ditch #2
Attachment E.	Electrical Locations
Attachment F.	Control Locations
Attachment G.	Ditch #1 Rotor
Attachment H.	Ditch #2 Rotor
Attachment I.	Other Related Drawings
Attachment J.	TN State Water Infrastructure Grant Identification Sign Diagram

ARTICLE II

CONTRACTOR agrees to furnish and pay for all material, supplies, tools, equipment, labor and other services required to do and perform all the WORK required to achieve substantial completion of the PROJECT within thirty (30) consecutive calendar days after the day specified in the NOTICE TO PROCEED (**Document O**) as the last day upon which the CONTRACTOR is to proceed, all in strict and complete compliance with the terms and conditions of this C&A and with the other CONTRACT DOCUMENTS for this PROJECT, all of which shall be deemed a part hereof as fully and completely as if set out and copied verbatim herein. The TOWN agrees to pay the CONTRACTOR for said work described in Article II as shown on the BID FORM and pursuant to the terms and conditions of this C&A and the other CONTRACT DOCUMENTS.

No payments under this C&A will be made except upon presentation of the monthly estimate form prepared by CONTRACTOR and approved by the TOWN, which shall show that the work covered by the periodic payment form has been done and the payments therefor are due in accordance with this C&A.

The first estimate shall be of the value of the work done since the commencement of performance by the CONTRACTOR pursuant to this C&A. Every subsequent estimate shall be for the work done since the CONTRACTOR's commencement of performance of this C&A, less the amount previously paid. If the CONTRACTOR fails to adhere to the program of completion provided for in the CONTRACT DOCUMENTS, the TOWN shall deduct from the next and all subsequent estimates the full calculated accruing amount of the liquidated damages (if any) to the date of said estimate until such time as compliance with the program has been restored. Because it would be

Contract Number: GS-24-01415 Bid Number: TC2024-42

Project Name: RE-BID SHELTON RD. WWTP OXIDATION DITCH ROTOR REPLACEMENT

difficult and/or impossible to determine the resulting costs/damages to the TOWN, liquidated damages are stipulated and agreed, under the circumstances, to be a fair and reasonable estimate of TOWN's potential damages at the time the parties have entered into the CONTRACT, and shall not be construed or otherwise considered to be a penalty.

The monthly estimates shall be submitted on a form acceptable to the TOWN signed by the TOWN ENGINEER, ARCHITECT, or other professional retained by the TOWN relative to the PROJECT, if any. Such estimates shall be subject to the approval of the TOWN. If the TOWN approves such estimates, the TOWN, subject to the foregoing provisions, will pay or cause to be paid to the CONTRACTOR, in the manner provided by law, an amount equal to NINETY-FIVE PERCENT (95%) of the estimated value of the WORK performed. (Please see FORM O-2, which is an exemplar form that the CONTRACTOR may utilize for its monthly construction estimate. The TOWN may approve the use of another format in its sole discretion.)

The CONTRACTOR shall, as soon as practical after final acceptance of the work under the C&A, make a final estimate of the amount of WORK done hereunder and the value thereof. Such final estimate shall be checked, approved and signed by the ENGINEER or ARCHITECT retained by the TOWN relative to the PROJECT, if any, and an official representative of the TOWN. After such approval, the TOWN shall pay, or cause to be paid, the CONTRACTOR, in the manner provided by law, the entire sum so found to be due hereunder after deducting therefrom all previous payments and such other lawful amounts as the terms of this C&A prescribe. The CONTRACTOR shall furnish security satisfactory to the TOWN (T.C.A. § 12-4-201) to indemnify the TOWN against any claim or lien if a SUBCONTRACTOR refuses to furnish a release or receipt in full. If

Contract Number: GS-24-01415 Bid Number: TC2024-42

Project Name: RE-BID SHELTON RD. WWTP OXIDATION DITCH ROTOR REPLACEMENT

any claim or lien remains unsatisfied after all payments are made, the CONTRACTOR shall refund to the TOWN all monies that the TOWN may be compelled to pay in discharging such a lien, including all costs and reasonable attorneys' fees incurred by the TOWN in defending against such claim or lien. Final payment will be made within thirty (30) consecutive calendar days after completion of the work and the acceptance of same by the TOWN and approval by the ENGINEER. Nothing contained herein shall be construed as signifying that a materialman or laborer has a right to a lien on the PROJECT, as such liens are not permitted by Tennessee law. Any party giving notice to the TOWN that such party has not been paid by the CONTRACTOR shall be referred by the TOWN to the CONTRACTOR and the SURETY on the bonds required to be posted by the CONTRACTOR relative to the PROJECT.

ARTICLE III

CONTRACTOR declares that neither the Mayor, nor any Aldermen, nor any other TOWN official holds a direct or indirect interest in this C&A. CONTRACTOR pledges that he will notify the Finance Director of the TOWN in writing should any TOWN official become either directly or indirectly interested in this C&A. CONTRACTOR declares that as of the date of this declaration he has not given or donated or promised to give or donate, either directly or indirectly, to any official or employee of the TOWN, or to pay anyone else for the benefit of any official or employee of the TOWN, any sum of money or other thing of value for aid or assistance in obtaining this C&A. CONTRACTOR further pledges that neither he nor any other officer or employee of CONTRACTOR will give or donate or promise to give or donate, directly or indirectly, to any official or employee of the TOWN or anyone else for the benefit thereof any sum of money or other thing of value for aid or assistance in obtaining any change order to this C&A.

ARTICLE IV

CONTRACTOR agrees to indemnify and save the TOWN, TOWN officers, TOWN agents, and TOWN employees harmless from and against all loss and expense, including court costs and attorneys' fees, by reason of liability imposed on the TOWN, TOWN officers, TOWN agents, or TOWN employees, for damage because of bodily injury, death or property damage arising out of or in consequence of the performance of the work under or in any manner related to this C&A, whenever such injury, death or damage is due or claimed to be due to the negligence or other fault of the CONTRACTOR, his SUBCONTRACTORS, officers, agents, and/or employees.

In the event the TOWN shall have occasion to either defend or assert its rights under this C&A in a court of law or equity, before a board of arbitration or otherwise, and if the TOWN shall prevail in any such action, either as defendant or plaintiff (as the case may be), CONTRACTOR shall pay any and all costs of such action, including court costs and reasonable attorneys' fees, incurred by the TOWN in asserting or defending its rights under this C&A.

All personal pronouns used in the CONTRACT DOCUMENTS, whether used in the masculine, feminine or neuter gender, shall include all other genders, the singular shall include the plural, and vice versa, as the context may require.

Contract Number: GS-24-01415 Bid Number: TC2024-42
Project Name: RE-BID SHELTON RD. WWTP OXIDATION DITCH ROTOR REPLACEMENT

WITNESS the due execution hereof, effective _____, 20_____, which date is the date of the signature of the Mayor as attested to by the TOWN Clerk/Recorder under seal of office.

[CONTRACTOR NAME]

By: _____

Title: _____

Address: _____

Phone No.: (_____) _____

Fax No.: (_____) _____

Email: _____

TOWN OF COLLIERVILLE, TENNESSEE

By: _____

Stan Joyner, Mayor

I certify that on the ____ day of _____, 20___, the signature of the Mayor was attested to by the TOWN Clerk under seal of office on the original of this CONTRACT AND AGREEMENT.

TOWN CLERK/RECORDER

Date: _____

Approved as to form and content:

TOWN DIRECTOR OF GENERAL SERVICES

Date: _____

PAYMENT BOND

KNOW ALL MEN BY THESE PRESENTS, that

_____ (*Name of CONTRACTOR*)

_____ (*Address of CONTRACTOR*), a

_____ (*State of formation of CONTRACTOR*)

_____ (*Corporation, Partnership, Limited Liability*

Company, Individual or Joint Venture—indicate which), hereinafter called CONTRACTOR,

and _____ (*Name of SURETY*)

_____ (*Address of SURETY*)

hereinafter called SURETY, are held and firmly bound unto the Town of Collierville, Tennessee,

500 Poplar View Parkway, Collierville, Tennessee, hereinafter called OWNER, in the penal sum

of _____ Dollars

(\$ _____), in lawful money of the United States, for the payment of which sum

well and truly to be made, we bind ourselves, and our successors, and assigns, jointly and severally,

firmly by these presents.

THE CONDITION OF THIS OBLIGATION is such that whereas, the CONTRACTOR has entered into a certain C&A with the OWNER, which is made a part hereof by reference for the construction of:

NOW, THEREFORE, if the CONTRACTOR shall promptly make payment to all persons, firms, and SUBCONTRACTORS furnishing materials for or performing labor in the prosecution

of the work provided for in such CONTRACT, and any extension or modification thereof, including, without limitation, all amounts for materials, lubricants, oil, gasoline, parts and repairs on machinery, equipment, and tools consumed or used in connection with such work, and all insurance premiums on said work, and for all labor performed in such work, whether by SUBCONTRACTORS or otherwise, then this obligation shall be void; otherwise, same is to remain in full force and effect.

PROVIDED, FURTHER, that said SURETY, for value received, hereby stipulates and agrees that no change, extension of time, modification, alteration, or addition to the terms of the CONTRACT, to the WORK to be performed thereunder or to the SPECIFICATIONS accompanying the same shall in any way release its obligation under this BOND. Said SURETY hereby waives notice of any such change, extension of time, modification, alteration, or addition to the terms of the work or to the SPECIFICATIONS.

PROVIDED, FURTHER, that no final settlement between the OWNER and the CONTRACTOR shall abridge the right of any beneficiary hereunder, whose claim is entitled to be satisfied by the CONTRACTOR and its SURETY.

PROVIDED, FURTHER, that the CONTRACTOR and SURETY agree that any claim under this BOND may only be litigated in a court of competent jurisdiction in Shelby County, Tennessee.

IN WITNESS WHEREOF, this instrument is duly executed, this the _____ day of _____, 20____.

(CONTRACTOR)

By: _____

Title: _____

Address: _____

(SURETY)

By: _____

(Attorney-in-Fact)

Title: _____

Address: _____

PERFORMANCE BOND

KNOW ALL MEN BY THESE PRESENTS, that

_____ (*Name of CONTRACTOR*)

_____ (*Address of CONTRACTOR*) a

_____ (*State of formation of CONTRACTOR*)

_____ (*Corporation, Partnership, Limited Liability*

Company, Individual or Joint Venture—indicate which), hereinafter called CONTRACTOR,

and _____ (*Name of SURETY*)

_____ (*Address of SURETY*)

hereinafter called SURETY, are held and firmly bound unto

the Town of Collierville, Tennessee, 500 Poplar View Parkway, Collierville, Tennessee,

hereinafter called OWNER, in the penal sum of

_____ Dollars

(\$ _____), in lawful money of the United States, for the payment of which sum

well and truly to be made, we bind ourselves, and our successors, and assigns, jointly and severally,

firmly by these presents.

THE CONDITION OF THIS OBLIGATION is such that, whereas, the CONTRACTOR has entered into a certain Contract and Agreement (“CONTRACT”) with the OWNER, which is made a part hereof by reference, for the construction of:

_____, and if

the CONTRACTOR shall satisfy all claims and demands incurred and perform all obligations

imposed upon it under such CONTRACT, and shall fully indemnify and save harmless the OWNER from all costs and damages which it may suffer by reason of failure to do so, and shall reimburse and repay the OWNER all outlay and expense which the OWNER may incur in making good any default, then this obligation shall be void; otherwise, same is to remain in full force and effect.

PROVIDED, FURTHER, that the said SURETY, for value received hereby, stipulates and agrees that no change, extension of time, modification, alteration, or addition to the terms of the CONTRACT or to the work to be performed thereunder or the SPECIFICATIONS accompanying the same shall in any way release its obligation on this BOND, and it does hereby waive notice of any such change, extension of time, modification, alteration, or addition to the terms of the CONTRACT, to the WORK, or to the SPECIFICATIONS.

PROVIDED, FURTHER, that no final settlement between the OWNER and the CONTRACTOR shall abridge the right of any beneficiary hereunder whose claim may be unsatisfied and which is entitled to be satisfied by the CONTRACTOR and SURETY.

PROVIDED, FURTHER, that the CONTRACTOR and SURETY agree that any claim under this BOND may only be litigated in a court of competent jurisdiction in Shelby County, Tennessee.

IN WITNESS WHEREOF, this instrument is duly executed this the _____ day of

_____, 20 ____.

(CONTRACTOR)

By: _____

Title: _____

Address: _____

(SURETY)

By: _____

(Attorney-in-Fact)

Title: _____

Address: _____

COLLIERVILLE INSURANCE REQUIREMENT TOWN PROJECT CONTRACT

The CONTRACTOR shall purchase and maintain such comprehensive general liability and other insurance as will provide protection from claims set forth below which may arise out of or result from the CONTRACTOR's performance of the WORK and the CONTRACTOR's other obligations under the CONTRACT DOCUMENTS, whether such performance is by the CONTRACTOR, by any SUBCONTRACTOR, by anyone directly or indirectly employed by any of them, or by anyone for whose acts any of them may be liable (whether vicariously or otherwise):

1. Claims under workers' or workmen's compensation, disability benefits and other similar employee benefit acts;
2. Claims for damages because of bodily injury, occupational sickness or disease, or death of the CONTRACTOR's employees;
3. Claims for damages because of bodily injury, sickness or disease, or death of any person other than the CONTRACTOR's employees;
4. Claims for damages which may be insured by personal injury liability coverage which are sustained (i) by any person as a result of an offense directly or indirectly related to the employment of such person by the CONTRACTOR, or (ii) by any other person for any other reason;
5. Claims for damages, other than to the work itself, because of injury to or destruction of tangible property, including loss of use resulting therefrom;
6. Claims for damages because of bodily injury or death of any person or property damage arising out of the ownership, maintenance or use of any motor vehicle; and
7. Claims by third parties for bodily injury and property damage arising or resulting from the CONTRACTOR's failure to comply with any obligation undertaken by him pursuant to the CONTRACT DOCUMENTS.

The automobile general liability insurance required by this CONTRACT shall include the specific coverages and be written for not less than \$1,000,000 bodily injury or death and \$500,000 property damage.

The comprehensive general liability insurance required by this Contract shall include the specific coverages and shall be written for not less than \$1 million combined per occurrence limit or \$2 million aggregate limit with the entire aggregate limits dedicated to this particular job.

The CONTRACTOR shall have and maintain during the life of the C&A such Property Insurance upon his entire WORK at the site to the full insurable value thereof. This insurance shall protect the TOWN, as its interest may appear in the work, and shall insure against the perils of fire and extended coverage and shall include "all risk" insurance for the physical loss or damage including,

without duplication of coverage, theft, vandalism and malicious mischief. Said policy shall protect the interest of the Named Insureds.

All such insurance shall be set out on the Certificate of Insurance (form included for both occurrence and aggregate policy) executed by an insurance company or insurance companies authorized to do business in the State of Tennessee. The Certificate of Insurance shall include an endorsement naming the TOWN as Additional Insured, and shall contain the following provision:

“The coverage provided shall not be canceled, reduced in coverage, or allowed to lapse unless and until the Town of Collierville receives advance written notice of same. Said written notice must be delivered to the TOWN DIRECTOR OF GENERAL SERVICES, 500 Poplar View Parkway, Collierville, Tennessee 38017.”

All such insurance shall remain in effect until final acceptance and at all times thereafter when the CONTRACTOR may be correcting, removing or replacing defective work in accordance with the C&A.

The comprehensive general liability insurance required by this section will include contractual liability insurance applicable to the CONTRACTOR’s obligations under the C&A.

The CONTRACTOR shall maintain through the life of the C&A insurance through insurer’s rated A- or better by A.M. Best.

CONTRACTOR expressly agrees and understands that any insurance protection required by the CONTRACT or otherwise provided by the CONTRACTOR shall in no way limit its responsibility to indemnify, defend, save, and hold harmless the TOWN, including its elected officials, employees, and instrumentalities.

The Contractor shall notify the TOWN, c/o Town of Collierville, DIRECTOR OF GENERAL SERVICES, 500 Poplar View Parkway, Collierville, Tennessee 38017, of any suit made or filed against CONTRACTOR resulting from or relating to the CONTRACTOR’s performance of its duties and/or obligations under the CONTRACT.

CERTIFICATE OF INSURANCE

For Contractors Doing Business With
Town of Collierville

(This Certificate does not amend, extend, or alter the coverage afforded by the policies listed below)

NAME AND ADDRESS OF AGENCY	COMPANIES AFFORDING COVERAGES
	COMPANY LETTER A
	COMPANY LETTER B
NAME AND ADDRESS OF INSURED	COMPANY LETTER C
	COMPANY LETTER D
	COMPANY LETTER E

This is to certify that policies of insurance listed below have been issued to the insured named above and are in force at this time.

COMPANY LETTER	TYPE OF INSURANCE	POLICY NUMBER	POLICY EXPIRATION DATE	LIMITS OF LIABILITY IN THOUSANDS (000)	
	GENERAL LIABILITY <input type="checkbox"/> Claims made or <input type="checkbox"/> Occurrence <input type="checkbox"/> Comprehensive form <input type="checkbox"/> Premises – Operation <input type="checkbox"/> Explosion & Collapse Hazard <input type="checkbox"/> Underground Hazard <input type="checkbox"/> Products/Completed Operations Hazard <input type="checkbox"/> Contractual Insurance <input type="checkbox"/> Broad Form Property Damage <input type="checkbox"/> Independent Contractors <input type="checkbox"/> Personal Injury			General Aggregate	\$
				Products-Comp/Ops Aggregate	\$
				Personal & Advertising Injury	\$
				Each Occurrence	\$
				Fire Damage (Any One Fire)	\$
				Medical Expense (Any One Person)	\$

*Contractor may utilize
ACORD Certificate of Property Insurance Form ACORD 25 (Most Current Version)*

CERTIFICATE OF INSURANCE*

For CONTRACTORS Doing Business
with the TOWN

COMPANY LETTER	TYPE OF INSURANCE	POLICY NUMBER	POLICY EXPIRATION DATE	LIMITS OF LIABILITY IN THOUSANDS (000)		
					EACH OCCURRENCE	AGGREGATE
	AUTOMOBILE LIABILITY			BODILY INJURY (EACH PERSON)	\$	\$
	() Comprehensive form					
	() Owned			BODILY INJURY (EACH ACCIDENT)	\$	\$
	() Hired					
	() Non-Owned					
	EXCESS LIABILITY			PROPERTY DAMAGE	\$	\$
	() Umbrella Form					
	() Other than Umbrella			BODILY INJURY & PROPERTY DAMAGE COMBINED	\$	\$
				BODILY INJURY & PROPERTY DAMAGE COMBINED	\$	\$
	WORKERS' COMPENSATION AND EMPLOYERS' LIABILITY	L.&H.W. ACT JONES ACT		STATUTORY	EACH	ACCIDENT
	OTHER					

** In lieu of this CERTIFICATE OF INSURANCE form, CONTRACTOR may utilize ACORD Certificate of Liability Insurance Form ACORD 25 (Most Current Version)*

CERTIFICATE OF INSURANCE

For CONTRACTORS Doing Business
with the TOWN

This is to certify further to the TOWN concerning the policies of insurance listed above and the coverage provided thereby that:

1. The contractual insurance coverage is on a blanket broad form basis unless otherwise indicated below;
2. The company or companies, upon request, agree to deliver within fifteen (15) consecutive calendar days a certified copy of any and/or all of the policies of insurance to the TOWN;
3. If one (1) or more umbrella excess policies are used, there is no gap between the limits of the primary policies and the deductible features of the umbrella policies;
4. Coverage under the primary policies has no deductible feature unless otherwise indicated below. If there are deductible features or the insured has adopted a funded self-insurance program, they are fully explained on an attached sheet which becomes a part of this Certificate; and
5. The coverage provided shall not be canceled, reduced, or allowed to lapse unless and until the TOWN receives advance written notice of same. Such written notice must be delivered to the TOWN's DIRECTOR OF GENERAL SERVICES, at the address shown below.

Name and Address of Certificate Holder

Date Issued: _____

Town of Collierville
Director of General Services
500 Poplar View Parkway
Collierville, TN 38017

(Name of Agency or Company)

By _____
(Authorized Representative)

This Certificate replaces a
Certificate dated _____.
(If applicable)

*CONTRACTOR may utilize
ACORD Certificate of Liability Insurance Form ACORD 25 (Most Current Version)*



TOWN OF COLLIERVILLE

PROFESSIONAL SERVICE/CONSTRUCTION APPLICATION FOR PAYMENT FORM



DATE:		TYPE OF CONTRACT (Select One)	REVIEWED BY:	PAYMENT TO:
TOC PROJECT #:		ARCHITECT		
APPLICATION #:		ENGINEER	ENGINEERING INSPECTOR	
PROJECT NAME:		CONSTRUCTION	DATE:	
		OTHER		
BID NUMBER:				
CONTRACT DATE:				
CONTRACT NUMBER:		PO#:	PROCUREMENT SPECIALIST	
PERIOD TO:			DATE:	INVOICE:
ACCOUNT NO.				INV DATE:

<p>APPLICATION FOR PAYMENT</p> <table style="width: 100%; border-collapse: collapse;"> <tr><td style="width: 5%;">1</td><td style="width: 85%;">ORIGINAL CONTRACT AMOUNT</td><td style="width: 10%;"></td><td style="width: 5%;"></td></tr> <tr><td>2</td><td>NET CHANGE BY CHANGE ORDERS</td><td></td><td></td></tr> <tr><td>3</td><td>CONTRACT SUM TO DATE (Line 1 ± Line 2)</td><td style="text-align: right;">\$</td><td style="text-align: center;">-</td></tr> <tr><td>4</td><td>TOTAL COMPLETED TO DATE</td><td></td><td></td></tr> <tr><td>5</td><td>RETAINAGE: (If Applicable)</td><td></td><td></td></tr> <tr><td>A.</td><td>5 % of Completed Work</td><td style="text-align: right;">\$</td><td style="text-align: center;">-</td></tr> <tr><td></td><td>(Line 4 X Line 5A)</td><td></td><td></td></tr> <tr><td>6</td><td>TOTAL EARNED LESS RETAINAGE</td><td style="text-align: right;">\$</td><td style="text-align: center;">-</td></tr> <tr><td></td><td>(Line 4 - Line 5 total)</td><td></td><td></td></tr> <tr><td>7</td><td>LESS SUM OF PREVIOUS PAYMENTS</td><td></td><td></td></tr> <tr><td>8</td><td>ADDITIONAL FEES DUE</td><td style="text-align: right;">\$</td><td style="text-align: center;">-</td></tr> <tr><td>9</td><td>OUT-OF-POCKET EXPENSES</td><td style="text-align: right;">\$</td><td style="text-align: center;">-</td></tr> <tr><td>10</td><td>CURRENT PAYMENT DUE</td><td style="text-align: right;">\$</td><td style="text-align: center;">-</td></tr> <tr><td>11</td><td>BALANCE TO FINISH, including retainage</td><td style="text-align: right;">\$</td><td style="text-align: center;">-</td></tr> <tr><td></td><td>(Line 3 - Line 6)</td><td></td><td></td></tr> </table>	1	ORIGINAL CONTRACT AMOUNT			2	NET CHANGE BY CHANGE ORDERS			3	CONTRACT SUM TO DATE (Line 1 ± Line 2)	\$	-	4	TOTAL COMPLETED TO DATE			5	RETAINAGE: (If Applicable)			A.	5 % of Completed Work	\$	-		(Line 4 X Line 5A)			6	TOTAL EARNED LESS RETAINAGE	\$	-		(Line 4 - Line 5 total)			7	LESS SUM OF PREVIOUS PAYMENTS			8	ADDITIONAL FEES DUE	\$	-	9	OUT-OF-POCKET EXPENSES	\$	-	10	CURRENT PAYMENT DUE	\$	-	11	BALANCE TO FINISH, including retainage	\$	-		(Line 3 - Line 6)			<p style="text-align: center;">SIGNATURE & NOTARIZATION OF COMPANY</p> <p style="text-align: center;">REQUESTING PAYMENT</p> <p style="text-align: center;">(Required for Construction Projects only)</p> <p>The undersigned certifies that to the best of their knowledge, information and belief the Work covered by this Application for Payment has been completed in accordance with the Contract Documents for this project, that all amounts have been paid by the Contractor to any sub-contractors and/or suppliers for which previous Application for Payments were issued and payments received from the Town of Collierville, and that current payment shown herein is now due.</p> <p>COMPANY NAME: _____</p> <p>Signature: _____ Date: _____</p> <p>State of: _____ County of: _____</p> <p>Subscribed and sworn to before me this _____ day of _____</p> <p>Notary Public: _____</p> <p>My Commission expires: _____</p> <p>* If CONSTRUCTION Contract: "Certification of Payment" section must be completed by architect/engineering firm.</p> <p>* If ARCHITECT/ENGINEERING/OTHER Contract: "Certification of Payment" section must be completed by Project Manager.</p> <p>* Project Manager & Dept. Director must approve <u>ALL</u> Applications for Payment</p>
1	ORIGINAL CONTRACT AMOUNT																																																												
2	NET CHANGE BY CHANGE ORDERS																																																												
3	CONTRACT SUM TO DATE (Line 1 ± Line 2)	\$	-																																																										
4	TOTAL COMPLETED TO DATE																																																												
5	RETAINAGE: (If Applicable)																																																												
A.	5 % of Completed Work	\$	-																																																										
	(Line 4 X Line 5A)																																																												
6	TOTAL EARNED LESS RETAINAGE	\$	-																																																										
	(Line 4 - Line 5 total)																																																												
7	LESS SUM OF PREVIOUS PAYMENTS																																																												
8	ADDITIONAL FEES DUE	\$	-																																																										
9	OUT-OF-POCKET EXPENSES	\$	-																																																										
10	CURRENT PAYMENT DUE	\$	-																																																										
11	BALANCE TO FINISH, including retainage	\$	-																																																										
	(Line 3 - Line 6)																																																												

<p>CERTIFICATION OF PAYMENT</p> <p>In accordance with the Contract Documents, based on on-site observations and the data comprising the application, the undersigned certifies that to the best of their knowledge, information and belief the Work has progressed as indicated, the quality of the Work is in accordance with the Contract Documents, and the Company is entitled to payment of the Amount Certified.</p> <p>AMOUNT CERTIFIED: _____</p> <p>Signature: _____ Date: _____</p> <p>Project Manager Approval: _____ Dept. Director Approval: _____</p>	
--	--

CONTINUATION SHEET / SCHEDULE OF VALUES

PROJECT _____ JOB NO. _____ ESTIMATE NO. _____

ITEM NO.	DESCRIPTION	VALUE OF ITEM AS REFLECTED IN BID	NO. OF UNITS	UNIT PRICE	AMENDED CONTRACT	QUANTITY THIS ESTIMATE	INSTALLED TO DATE	AMOUNT EARNED TO DATE	MATERIALS STORED	MATERIALS COMPLETED	BALANCE OR OVERUN (-)	RETAINAGE

TOTALS _____

This is an exemplar form that the CONTRACTOR may utilize for its monthly construction estimate. The TOWN may approve the use of another format in its sole discretion.

Stan Joyner
Mayor

Maureen Fraser, Alderman
Billy Patton, Alderman
John Stamps, Alderman
Missy Marshall, Alderman
John Worley, Alderman



Molly B. Mehner
Town Administrator

Kristie Diamond
Town Clerk

The Town of Collierville

NOTICE OF AWARD

TO: _____

DATE: _____

CONTRACT NO: GS-24-01415

Dear _____:

This is to inform you that by action of the TOWN Board of Mayor and Aldermen during their meeting on Month Day, 20XX, your firm was awarded the CONTRACT for TC2024-42 RE-BID SHELTON RD. WWTP OXIDATION DITCH ROTOR REPLACEMENT in the amount of \$ _____.

Enclosed you will find the C&A (which you have previously executed), and the Performance and Payment Bonds for you to have executed as set forth on Pages "H-1 through H-3" of INFORMATION FOR SUCCESSFUL BIDDER, of the SPECIFICATION BOOKLET. Further, you should have your insurance agent execute the insurance certificate exactly as it is found in the Collierville Insurance Requirements. **You have fifteen (15) consecutive calendar days after receipt hereof to return the above required documents, properly executed, to the TOWN.**

Additionally, as set forth on Page "GP-4" of GENERAL PROVISIONS, of the SPECIFICATION BOOKLET, you are required to present at the Pre-Construction Conference:

1. A general sequence of operations (schedule of work), including major WORK items along with anticipated completion dates;
2. A list of all SUBCONTRACTORS to be used in the execution of the WORK under this PROJECT; and
3. ADDITIONAL INFORMATION AS REQUESTED BY PROJECT MANAGER.

Failure to present these documents as required at the Pre-Construction Meeting will result in the Notice to Proceed being withheld until all required information has been received.

CONTRACT No. GS-24-01415 has been issued as the identification for this CONTRACT. All further correspondence, documentation and payment requests must reference this number for processing.

Congratulations on being the successful BIDDER for this PROJECT.

Sincerely,

Procurement Manager

Enclosure

500 Poplar View Parkway • Collierville, Tennessee 38017 • (901) 457-2200 • Fax: (901) 457-2207

Stan Joyner
Mayor

Maureen Fraser, Alderman
Billy Patton, Alderman
John Stamps, Alderman
Missy Marshall, Alderman
John Worley, Alderman



Molly B. Mehner
Town Administrator

Kristie Diamond
Town Clerk

The Town of Collierville

NOTICE TO PROCEED

TO: _____

DATE: _____

PROJECT: RE-BID SHELTON RD. WWTP
OXIDATION DITCH ROTOR REPLACEMENT
BID NO: TC2024-42
CONTRACT NO: GS-24-01415

Relative to the above-referenced project, this is your official Notice to Proceed within ten (10) consecutive calendar days of the date hereof and to complete the work within the time specified in the C&A entered into by you and the TOWN.

Contract No. GS-24-01415 has been issued as identification for this C&A. All further correspondence, documentation and payment requests must reference this number for processing.

TOWN OF COLLIERVILLE

By: _____
Title: Procurement Manager

ACCEPTANCE OF NOTICE TO PROCEED:

Receipt of the above NOTICE TO PROCEED is hereby acknowledged by _____ this the ____
day of _____, 2024.

By: _____

Title: _____

NOTE: The CONTRACTOR must promptly sign and return to the TOWN a copy of this Notice to Proceed.

Substantial Completion Date: _____
Liquidated Damages: \$250.00

500 Poplar View Parkway • Collierville, Tennessee 38017 • (901) 457-2200 • Fax: (901) 457-2207

Stan Joyner
Mayor

Maureen Fraser, *Alderman*
Billy Patton, *Alderman*
John Stamps, *Alderman*
Missy Marshall, *Alderman*
John Worley, *Alderman*



Molly B. Mehner
Town Administrator

Kristie Diamond
Town Clerk

The Town of Collierville

NOTICE OF PROJECT ACCEPTANCE

Town of Collierville
General Services Department
500 Poplar View Parkway
Collierville, Tennessee 38017

Date: _____
Bid Number: TC2024-42
Project Name: RE-BID SHELTON RD. WWTP
OXIDATION DITCH ROTOR
REPLACEMENT
Contract: GS-24-01415

This is to advise you that all items set forth on the Punch List for the Project referenced above have been completed to our satisfaction, and the Project is accepted by the TOWN on _____.

TOWN OF COLLIERVILLE

By: _____
Name: _____
Title: _____

**TOWN OF COLLIERVILLE
CONTRACT CHANGE ORDER FORM**

Form #F0110B



PROJECT NAME _____
 CONTRACTOR _____
 PROJECT MANAGER _____
 AWARDED CONTRACT AMOUNT _____

DATE _____
 CONTRACT # _____
 CONTRACT DATE _____
 CHANGE ORDER # _____

THE CONTRACT IS AMENDED AS FOLLOWS:

ITEM #	DESCRIPTION OF CHANGES/JUSTIFICATIONS	DECREASE IN CONTRACT AMOUNT	INCREASE IN CONTRACT AMOUNT
TOTALS			

ORIGINAL CONTRACT AMOUNT \$ _____
 NET CHANGES BY PREVIOUSLY AUTHORIZED CHANGE ORDERS \$ _____
 CONTRACT SUM PRIOR TO THIS CHANGE ORDER \$ _____
 CONTRACT SUM WILL BE INCREASED/DECREASED BY THIS CHANGE ORDER IN THE AMOUNT OF \$ _____
NEW CONTRACT SUM INCLUDING THIS CHANGE ORDER \$ _____

ORIGINAL CONTRACT COMPLETION DATE _____
 CONTRACT COMPLETION CHANGE +/- (# OF DAYS) _____
 CONTRACT COMPLETION DATE ADJUSTMENT TO _____

Agreed by: _____ **Agreed by:** _____ **Reviewed by:** _____
 Project Manager Date Dept. Director (if applicable) Date Contract Specialist Date

Effective upon execution by the Mayor, following approval by the Board of Mayor and Aldermen, the above referenced Contract is amended by the terms and conditions of this Change Order, including the cost and time contained herein, which constitute a full accord and complete satisfaction for all costs and time of performance related to the work described or referenced herein, including but not limited to, all delay and impact costs for the entire Project resulting from this Change Order. Except as amended herein, all provisions of the Contract remain in full force and effect and are hereby ratified and affirmed by the parties to the Contract.

Recommended by: _____ Agreed by: _____ Agreed by: _____
 Architect/Eng. (If Applicable) Contractor Town of Collierville
 Address Address Address
 500 Poplar View Parkway Parkway
 Collierville, TN 38017
 By: (Signature) By: (Signature) By: Stan Joyner,
 (Typed Name) (Typed Name) Mayor
 Its: _____ Its: _____ Attest:
 Date: _____ Date: _____ Town Clerk/Recorder
 Date: _____

GENERAL PROVISIONS
TABLE OF CONTENTS

1. DEFINITIONS
2. SCOPE OF THE CONTRACT
3. WORK ITEMS AND MATERIALS NOT LISTED IN THE BID
4. PRE-CONSTRUCTION CONFERENCE
5. ENGINEER'S DECISION
6. INSPECTOR'S RESPONSIBILITY
7. CONTRACTOR'S RESPONSIBILITY
8. SITE OF THE WORK
9. CONTRACTOR'S SUPERVISION
10. CARE OF THE WORK
11. VEHICULAR TRAFFIC AND PEDESTRIAN WARNINGS
12. SCHEDULE OF WORK
13. WORKMANSHIP, TOOLS AND CONSTRUCTION EQUIPMENT
14. CODES, ORDINANCES, REGULATIONS, LAWS, PERMITS, LICENSES AND FEES
15. DRAWINGS AND SPECIFICATIONS
16. STANDARD PUBLICATIONS
17. STANDARD EQUIPMENT AND EQUIPMENT INSTALLATION
18. STANDARDS FOR MATERIALS
19. SAMPLES
20. MATERIALS, SERVICES AND FACILITIES
21. INSPECTION AND TESTING OF MATERIALS
22. PATENTS
23. ACCURACY OF DATA AND INTERFERENCES
24. LINES, GRADES, STAKES, AND TEMPLATES
25. WATER AND ELECTRICITY FOR CONSTRUCTION
26. LAND ACQUISITIONS AND RIGHTS OF WAY
27. EXISTING UTILITIES, STRUCTURES, AND OTHER PROPERTY
28. EXISTING UTILITY RELOCATIONS AND/OR ADJUSTMENTS
29. ACCESS TO PROPERTIES DURING CONSTRUCTION
30. EROSION AND SILTATION
31. AIR QUALITY PROTECTION
32. PROTECTION OF THE WORK
33. CONTRACT SECURITY
34. WAGE RATES
35. SUBCONTRACTING
36. PAYMENTS BY CONTRACTORS
37. TIME FOR COMPLETION
38. SUBSTANTIAL COMPLETION
39. PARTIAL OCCUPANCY OR USE
40. FINAL INSPECTION AND FINAL PAYMENT
41. LIQUIDATED DAMAGES
42. NOTICES AND SERVICE THEREOF
43. RIGHTS OF THE OWNER TO TERMINATE CONTRACT

- 44. **ASSIGNMENT OF CONTRACT**
- 45. **CLAIMS FOR EXTRA COST**
- 46. **CHANGES IN WORK**
- 47. **SANITARY FACILITIES**
- 48. **CUTTING AND PATCHING**
- 49. **REMOVAL OF DEBRIS/CLEAN UP**
- 50. **USE OF COMPLETED WORK**
- 51. **STARTING, TESTING, AND ADJUSTING**
- 52. **LABORATORY TESTING**
- 53. **TAXES**
- 54. **GUARANTEE**
- 55. **SAFETY AND HEALTH REGULATIONS**
- 56. **ARCHITECTURAL PROVISIONS**
- 57. **MODIFICATIONS TO GENERAL PROVISIONS**

1. **DEFINITIONS**

- A. The words “OWNER” and “TOWN” mean the Town of Collierville.
- B. The word “ENGINEER” means the TOWN Engineer, PROJECT MANAGER, or ARCHITECT of TOWN.
- C. The word “INSPECTOR” means a TOWN inspector.
- D. The word “CONTRACTOR” means the successful BIDDER, unless otherwise expressly stated.
- E. The words “install”, “furnish”, “provide”, or words of like import mean the CONTRACTOR shall install, furnish, or provide, and similarly, the words “approved”, “authorized”, “required”, “satisfactory”, “acceptable”, or words of like import mean approved by, authorized by, required by, satisfactory to, or acceptable to the ENGINEER, unless otherwise expressly stated.
- F. The words “indicated”, “shown”, “detailed”, or “scheduled” mean indicated, shown, detailed, or scheduled on the CONTRACT drawings, unless otherwise expressly stated.
- G. The word “WORK” means the labor, materials, equipment, supplies, and services to be furnished under the CONTRACT, and the performing of all duties and obligations required by the CONTRACT DOCUMENTS.
- H. The word “submit” means the CONTRACTOR shall submit to the ENGINEER for approval, unless otherwise expressly stated.
- I. The word “provide” means the CONTRACTOR shall furnish and install, complete and ready for use, unless otherwise expressly stated.
- J. The word “selected” means selected by the ENGINEER, unless otherwise expressly stated.

- K. The term “substantial completion” means the stage in the progress of the WORK when the WORK or designated portion thereof is sufficiently complete in accordance with the CONTRACT DOCUMENTS so that the OWNER can occupy or utilize the WORK for its intended use.
- L. The term “TOC CONSTRUCTION STANDARDS” means the Town specifications listed in the Town of Collierville Standard Construction Specifications and Town of Collierville Standard Details, unless otherwise expressly stated. The TOWN’S Standard Construction Specifications and Standard Details are available on the TOWN’S Engineering Division webpages at www.colliervilletn.gov or by contacting the Engineering Division by email at engineering@colliervilletn.gov or by telephone at (901) 457-2340.
- M. The term “shop drawings” means the drawn version of information shown in the CONTRACT DOCUMENTS and typically used to explain the fabrication and/or installation of particular items to installation crews.
- N. The term “furnish” means to deliver and/or make available for inspection without delay.
- O. The term “samples” means tangible exemplars of the work to be performed or a component part of the work to be performed pursuant to the SPECIFICATIONS.
- P. The term “SPECIFICATIONS” means the portion of the CONTRACT DOCUMENTS consisting of the written requirements for materials, equipment, systems, standards and workmanship for the WORK, and the performance of related services. (AIA Document A201-2007)

2. SCOPE OF THE CONTRACT

The WORK required under this CONTRACT consists of supplying all materials and labor for the direct replacement of two (2) oxidation ditch rotors at the Shelton Road Wastewater Treatment Plant. Replacement will include replacing one 24’-0” brush rotor with a 36’-0” aerator bridge and one 24’-0” brush rotor with a 34’-0” aerator bridge. Both rotors are located at the Shelton Road Wastewater Treatment Plant, located at 136 E. Shelton Road, Collierville, TN 38017.

3. WORK ITEMS AND MATERIAL NOT LISTED IN THE BID

Cost for WORK and/or material and/or services not specifically listed in the BID but needed for a complete product as set forth in the Drawings and Specifications shall be incidental to the WORK items listed in the BID, unless otherwise shown on the drawings or specified herein.

4. PRE-CONSTRUCTION CONFERENCE

- A. After the CONTRACT is awarded, and incident to the issuance of the NOTICE TO PROCEED, the ENGINEER MAY conduct a pre-construction conference.

- B. The CONTRACTOR shall be prepared during the conference or otherwise upon request to:
1. Present a general sequence of operations, including major WORK items along with anticipated completion dates.
 2. Present a list, including contact information, of all SUBCONTRACTORS to be used in the execution of the WORK under this PROJECT.
 3. Discuss any of the submittals and/or respond to any questions the OWNER may have regarding the submittals.
 4. Advise the OWNER of all anticipated construction problems and difficulties with the OWNER'S operations, and present plans to avoid unnecessary interference therewith.
 5. Discuss conflicts between the proposed WORK and any existing utilities with the representatives of the affected utilities. Determine the relocation plans, if required, of the utilities and develop a schedule that will coordinate the relocation plans of the utility with the WORK.
 6. Obtain the interpretation, clarification, and/or the OWNER'S decision concerning requirements of the drawings, specifications, or other CONTRACT DOCUMENTS which the CONTRACTOR finds unclear.
 7. Discuss any other items pertaining to the WORK, as desired.
- C. The ENGINEER will furnish to the CONTRACTOR minutes of the Pre-Construction Conference, verifying the interpretations, clarification, instructions, agreements, and other information pertinent to the PROJECT resulting from the conference.

5. ENGINEER'S DECISION

The ENGINEER shall in all cases determine the amount, quality, acceptability, and fitness of the several kinds of finished WORK and materials which are to be paid for hereunder, and shall decide all questions which may arise as to fulfillment of this CONTRACT on the part of the CONTRACTOR, and the ENGINEER'S interpretation of the CONTRACT and the ENGINEER'S determination and decision thereto shall be final and conclusive. Such determinations and decisions, in case any question arises, shall be a condition precedent to the CONTRACTOR'S right to receive any money hereunder. The ENGINEER shall have the right to correct all clerical, mathematical, or minor errors or omissions in the specifications when such corrections are necessary for the proper coordination of the CONTRACT DOCUMENTS.

6. INSPECTOR'S RESPONSIBILITY

The INSPECTOR will visit the job periodically to see that the terms of the Drawings and Specifications are being performed in general accordance with the CONTRACT DOCUMENTS. Should the INSPECTOR be needed by the CONTRACTOR or his representative, these individuals may call the TOWN OF COLLIERVILLE DEPARTMENT OF DEVELOPMENT to arrange a time that the INSPECTOR will confer

with the CONTRACTOR about any aspect of the job, but the INSPECTOR will not give instructions to the CONTRACTOR. The CONTRACTOR will be responsible for compliance with the plans and specifications and all requirements of the CONTRACTOR. The INSPECTOR may advise the CONTRACTOR or his representative that changes in the WORK should be accomplished. The INSPECTOR, acting through the authority of the TOWN ENGINEER, can reject work which clearly does not meet the requirements of the TOWN.

7. CONTRACTOR'S RESPONSIBILITY

- A. From commencement until completion and final acceptance by the OWNER, the work under this CONTRACT shall be under the charge and control of the CONTRACTOR. During such period of control by the CONTRACTOR, all risks in connection with the construction of the work and the materials to be used therein shall be borne by the CONTRACTOR.
- B. The CONTRACTOR shall be fully responsible for the safety and protection of all persons and of all work and material connected with his CONTRACT until the PROJECT is finally accepted by the OWNER. The CONTRACTOR shall use proper precautions to fully protect all persons, his own WORK and that of others, and the property of the OWNER and others from injury and damage, and at his own expense he shall be liable for injury to all persons and shall make good all damage and injury to property belonging to the OWNER and others caused by himself and his employees through negligence, carelessness, or any other cause.
- C. The OWNER and ENGINEER shall not be responsible for the methods and means employed by the CONTRACTOR in the performance of the CONTRACTOR'S work. The OWNER and ENGINEER shall have no responsibility for the safety of the workmen and others who may be injured during the course of the CONTRACTOR'S work.
- D. The CONTRACTOR must have a designated representative available on short notice who is capable of making decisions and giving directions at any time there is WORK ongoing.

8. SITE OF THE WORK

- A. Each CONTRACTOR submitting a BID or a proposal on this PROJECT and each SUBCONTRACTOR estimating and furnishing a bid under any division and/or section of this CONTRACT to the CONTRACTOR shall visit the site of the WORK and examine its present condition to inform himself as to the nature and scope of all work to be done and all difficulties that may be involved therein.
- B. The submission of a BID or a proposal by the CONTRACTOR to the OWNER or a BID furnished by a SUBCONTRACTOR to the CONTRACTOR shall be accepted as evidence that the examination referred to in General Provisions, Item 8A above has been made and that all difficulties encountered have been considered and provided for in his proposal or BID. Later foreseeable claims for extra compensation for labor, materials, and equipment will therefore not be recognized by the OWNER.

9. CONTRACTOR'S SUPERVISION

- A. The CONTRACTOR, or his duly authorized agent with authority to control the WORK, shall be present at the site whenever the work is in progress. The CONTRACTOR'S authorized agent shall meet with the approval of the ENGINEER.
- B. The OWNER reserves the right to require the removal from the PROJECT of the Superintendent or any other employee of the CONTRACTOR if, in the ENGINEER'S judgment, such removal is necessary to protect the OWNER'S interest.

10. CARE OF THE WORK

- A. The CONTRACTOR shall indemnify and save harmless the OWNER, the ENGINEER, their agents, and their employees from all claims, suits, or proceedings of any nature whatsoever which may be brought against the OWNER, the ENGINEER, their agents, or their employees on account of any injuries to persons or property received from the CONTRACTOR or his agents, servants, or SUBCONTRACTORS. See also General Provisions, Item 35 hereinafter.
- B. The CONTRACTOR shall be responsible for the proper care and protection of all materials delivered and WORK performed until completion and final acceptance of the PROJECT. The CONTRACTOR shall provide adequate barricades and warning signs to properly protect his WORK and to safeguard the life and property of others. Barricades, open trenches, etc. shall be properly illuminated with flares and/or blinking lights at night.
- C. Artifacts uncovered, recovered, or discovered during testing, excavation, or any other WORK on TOWN-owned or maintained properties shall remain the property of the TOWN. The CONTRACTOR shall be required to discontinue the WORK and notify the ENGINEER immediately upon encountering such artifacts. The removal of any such item from the WORK SITE by any person other than the ENGINEER or his designee will be considered theft of government property and will be prosecuted to the fullest extent of the law.

11. VEHICULAR TRAFFIC AND PEDESTRIAN WARNINGS

The CONTRACTOR shall:

- A. Schedule and perform all work to interfere as little as possible with vehicular and pedestrian traffic flow. Poor planning and gross inconsideration of traffic flow will be just cause to stop the CONTRACTOR'S work until the unsatisfactory conditions have been remedied.
- B. Mark clearly all open ditches, open excavations, soft backfill, parked equipment, etc. with signs, fences, and/or barricades during daytime hours, and, in addition, with lights at night and maintain all flares, signs, fences, and/or barricades during weekend, holiday and all other times when work is not in progress.

- C. Provide adequate signage, barricades, fences, and watchmen to comply with the requirements of all authorities having jurisdiction, and, as necessary, for the safety and convenience of the general public.
- D. All traffic control / warning devices used shall conform to Section VI of the Manual on Uniform Traffic Control Devices as adopted by the Federal Highway Administration and the Tennessee Department of Transportation.
- E. All existing structures, trees, fences, etc. that are not required to be removed in the execution of the WORK shall be preserved as specified in the appropriate sections of the SPECIFICATIONS portion of this document.

12. SCHEDULE OF WORK

- A. Before beginning work, the CONTRACTOR shall submit a construction schedule to the ENGINEER for approval. In general, the CONTRACTOR'S work shall be so scheduled as to interfere as little as possible with the operations of the OWNER and other contractors. All work shall be performed after 7:00 a.m. and before 6:00 p.m., local time, Monday through Friday unless a specific requirement for overtime work is included elsewhere in the CONTRACT, or is specifically granted by the ENGINEER. No work shall be performed on a Saturday or TOWN recognized holiday without the express written permission of the ENGINEER. No work shall be performed on a Sunday.
- B. The TOWN will use the CONTRACTOR'S WORK schedule to prepare notification to individual property owners of the general date(s) that they may expect WORK to be performed in areas adjoining their property. It will be the CONTRACTOR'S responsibility to keep the TOWN advised of any significant changes in the WORK schedule in a timely manner so that the affected private property owners may be kept informed.
- C. An updated work schedule must be furnished with every submitted payment request through Final Completion.

13. WORKMANSHIP, TOOLS AND CONSTRUCTION EQUIPMENT

- A. All work shall be performed in a finished and workmanlike manner, and in accordance with the best-recognized trade practices.
- B. The CONTRACTOR shall provide and maintain in good operating condition all tools and construction equipment necessary for the satisfactory performance of the WORK. Inadequate, unsuitable, defective, worn out, or otherwise unsatisfactory tools and construction equipment shall be removed from the site and replaced with satisfactory tools and construction equipment or the proper repairs shall be made or the unsatisfactory conditions shall be remedied.

14. CODES, ORDINANCES, REGULATIONS, LAWS, PERMITS, LICENSES AND FEES

- A. The CONTRACTOR shall comply with all TOWN, County, State and Federal codes, ordinances, regulations and laws applicable to the work to be done and applicable to the use of public streets, alleys and highways. Such codes, ordinances, regulations and laws shall be considered as minimum requirements, and everything shown or specified in the CONTRACT DOCUMENTS in excess of these minimum requirements shall be installed in excess thereof, as shown or specified. No instructions given in the CONTRACT DOCUMENTS shall be construed as an authorization to violate any code, ordinance, regulation or law.
- B. Before beginning work, the CONTRACTOR shall obtain all licenses and permits required by the TOWN (and any other governmental authorities) to perform work covered by this CONTRACT. The CONTRACTOR shall obtain all necessary inspections by all applicable authorities. The OWNER will waive the costs associated with inspections required by the TOWN, provided, however that CONTRACTOR shall be responsible for payment of all re-inspection fees for the PROJECT. The costs associated with inspections required by other jurisdictions or governing bodies, if any, shall be paid by the CONTRACTOR. Whereas certain parts of the WORK may require the approval of public or other authorities, all work shall be subject to the ENGINEER'S decision before proceeding with the portion of the WORK involved.

15. DRAWINGS AND SPECIFICATIONS

- A. The drawings accompanying these specifications, and forming a part thereof, are listed elsewhere and, together with the specifications, they cover the work to be performed under the CONTRACT. The CONTRACTOR and each SUBCONTRACTOR employed on this work shall carefully examine all CONTRACT drawings and read all specifications. They will be bound by all things therein affecting their special work no matter under what heading they may appear.
- B. The drawings and specifications are intended to cover a complete PROJECT ready for use, and all items necessary for a complete and workable job shall be furnished and installed. All minor items not specifically covered by the drawings and specifications but required in the construction of the PROJECT shall be furnished and installed as though shown or specified. This is not intended to cover major items of equipment or labor not shown or specified, but it is intended and will be interpreted to cover all miscellaneous labor, parts, devices, accessories, controls, and appurtenances which are: required by all applicable codes, ordinances, laws, and regulations; required to complete and place the PROJECT in satisfactory operation; and required for a first-class job that is complete in every respect.
- C. The drawings and specifications are mutually explanatory and supplementary, and all features covered in one and not in the other shall have the same force and effect as though covered in both. In the event of any conflicts between the drawings and specifications, the ENGINEER'S decision shall govern. Should any error, discrepancy, or variance be discovered in the drawings or specifications by the CONTRACTOR or his SUBCONTRACTOR, the CONTRACTOR shall immediately notify the ENGINEER before beginning the WORK and submit the question to the ENGINEER for his interpretation and decision. The ENGINEER will be governed by the overall meaning of the documents.

- D. The CONTRACTOR shall keep at least one copy of all drawings and specifications on the PROJECT site in good condition and available to the ENGINEER and to his representatives at all times.
- E. No deviations from the drawings and specifications shall be made without the ENGINEER'S prior written approval.
- F. The GENERAL PROVISIONS and the SPECIAL CONDITIONS shall apply to every division and/or section of the BID DOCUMENTS, as fully as if quoted verbatim therein.

16. STANDARD PUBLICATIONS

Wherever in these documents reference is made to standards, codes, or other standard publications, such as "ASTM" (American Society for Testing and Materials), "AASHTO" (American Association of State Highway and Transportation Officials), "ANSI" (American National Standards Institute), "AWWA" (American Waterworks Association), "ACI" (American Concrete Institute), "AISC" (American Institute of Steel Construction), "AWS" (American Welding Society), Federal Specifications, "NEC" (National Electrical Code), or others, in all cases the latest published editions of such referenced standard publications in effect at the time of receipt of bids shall apply.

17. STANDARD EQUIPMENT AND EQUIPMENT INSTALLATION

Except where special equipment is required, it is the general intent hereof that manufacturers' standard equipment shall be furnished. Minor variations from the SPECIFICATIONS to accommodate manufacturers' standard equipment will be permissible; provided that the ENGINEER approves of such variation and that the proposed equipment complies substantially with the SPECIFICATIONS and that it will accomplish the required results, all to the ENGINEER'S satisfaction.

18. STANDARDS FOR MATERIALS

- A. All materials shall be new, unless used or salvaged materials are authorized by the ENGINEER.
- B. The use of manufacturers' names and catalog numbers in these specifications or on the drawings indicates the type, size, rating, capacity, design, quality, or kind of materials required, and a closed specification is not intended, and similar and equal products of any reputable manufacturer which will satisfactorily perform the required functions will be acceptable, unless otherwise indicated by the words NO SUBSTITUTES, or unless otherwise specifically stated. The ENGINEER reserves the right to reject all materials that he deems not equal to those specified, or which he decides will not satisfactorily perform the required functions.
- C. As promptly as possible after award of CONTRACT, and prior to the purchase of materials, the CONTRACTOR shall submit to the ENGINEER for approval a complete list of all proposed materials. The CONTRACTOR shall include with such list complete catalog data and descriptive literature of all materials.

19. SAMPLES

The CONTRACTOR shall “furnish” to the ENGINEER for approval all “samples” as specified or requested. Unless otherwise specified, the CONTRACTOR shall furnish duplicate samples of adequate size showing quality, type color range, finish, texture, or other specified features. The work shall be in accordance with approved samples.

20. MATERIALS, SERVICES AND FACILITIES

Except as otherwise specifically stated in the CONTRACT DOCUMENTS, the CONTRACTOR shall provide and pay for all materials, labor, tools, equipment, water, light, power, transportation, superintendence, temporary construction of every nature, and all other services and facilities of every nature whatsoever necessary to execute, complete and deliver the WORK within the specified time.

21. INSPECTION AND TESTING OF MATERIALS

Where specifically provided for in the specifications, the inspection and testing of materials and finished articles to be incorporated in the work at the site shall be made by bureaus, laboratories, or agencies approved by the ENGINEER. Unless otherwise expressly stated, the cost of such inspection and testing shall be paid by the CONTRACTOR. The CONTRACTOR shall furnish evidence satisfactory to the ENGINEER that the materials and finished articles have passed the required tests prior to the incorporation of such materials and finished articles in the WORK. The CONTRACTOR shall promptly segregate and remove rejected materials and rejected finished articles from the site of the WORK.

22. PATENTS

The CONTRACTOR shall hold and save harmless the OWNER and its elected officials, agents, servants, and employees from liability of any nature or kind, including costs, expenses, and attorneys’ fees, for or on account of any patented or unpatented invention, process, article, or appliance manufactured or used in the performance of the CONTRACT, including its use by the OWNER, unless otherwise specifically stipulated in the CONTRACT DOCUMENTS.

23. ACCURACY OF DATA AND INTERFERENCES

- A. Before beginning any WORK, the CONTRACTOR shall carefully examine the site of the WORK and all CONTRACT Drawings, and shall verify all dimensions, elevations, and all existing conditions.
- B. All WORK shall be installed to conform as nearly as possible with the dimensions, elevations, locations, and arrangements indicated, with only such minor adjustments as necessary to coordinate the work of the various trades and specification divisions and/or sections; coordinate the WORK of this CONTRACT with that of other contracts; accommodate the actual equipment furnished; avoid all interferences between the various parts of the WORK; and accommodate existing conditions which may differ from those

indicated. Any and all parts of the WORK installed under this CONTRACT which interfere with other parts of the WORK or other contracts or which deviate from the drawings and specifications without the ENGINEER'S prior approval shall be altered by the CONTRACTOR, at his own expense, to clear such interferences and/or to fully comply with the drawings and specifications. All interferences or discrepancies that may be discovered or anticipated shall be reported promptly to the ENGINEER for decision before proceeding with the WORK. The ENGINEER shall have the privilege of authorizing minor changes without additional cost, provided that such changes are made prior to the commencement of WORK on the item involved.

24. LINES, GRADES, STAKES, AND TEMPLATES

- A. At his own expense, the CONTRACTOR shall furnish all stakes, templates, patterns, platforms, and labor that may be required in setting and cutting or laying out each part of the work.
- B. The CONTRACTOR shall also, at his own expense, furnish locations and benchmarks reasonably necessary for the execution of the work. The CONTRACTOR shall furnish all lines and grades and will be held responsible for the proper execution of the work to such lines and grades. Lines and grade stakes that are destroyed shall be replaced by the CONTRACTOR at his own expense.
- C. The construction of horizontal and vertical control staking shall be performed by a licensed engineer or land surveyor acceptable to the OWNER.
- D. The following shall be the minimum requirements of the PROJECT for construction control staking:
 - 1. Establish Centerline or Baseline Control
 - a) Establish in field all horizontal and vertical control points.
 - b) Establish in field points on line of Centerline or Baseline.
 - i. Maximum 100' intervals for straight tangents.
 - ii. Maximum 50' intervals for horizontal curves.
 - c) The stationing used shall correspond to the Centerline or Baseline stationing used in the plans. All points shall be labeled with the appropriate station.
 - d) All control points shall be referenced so they may be easily and accurately re-established.
 - e) The establishment of the Centerline or Baseline Control for the entire PROJECT shall be established before any construction staking will be undertaken.
 - 2. Field notes shall be kept in a Surveyor's Field Book of all construction and staking performed. The Field Book shall be available for review or reference by the OWNER or CONTRACTOR at all times.

25. WATER AND ELECTRICITY FOR CONSTRUCTION

- A. Water: At no cost to the CONTRACTOR, the OWNER will furnish all necessary water for testing, sterilizing, flushing, dust control and other construction purposes, subject to following conditions:
1. Water will be available from existing facilities at locations designated by the TOWN. The CONTRACTOR shall obtain a fire hydrant use permit, and keep and maintain a fire hydrant meter in operation. The fee for the permit will be waived; however the CONTRACTOR should be prepared to provide the estimated quantity of water to be used. The CONTRACTOR shall provide all necessary hoses, temporary pipework, portable tanks, and other equipment to convey and use water. In the event that the fire hydrant meter is returned damaged or broken, CONTRACTOR shall reimburse OWNER at the OWNER'S then current fee schedule for replacing said meter.
 2. The CONTRACTOR and SUBCONTRACTORS shall carefully conserve all water, and not waste it unnecessarily. If, in the opinion of the OWNER, the CONTRACTOR is using excessive amounts of water, the OWNER may require the CONTRACTOR to begin paying for all water used after such determination.
- B. Electricity: At its own expense, the CONTRACTOR shall provide all electric power for the PROJECT construction.

26. LAND ACQUISITIONS AND RIGHTS OF WAY

The properties on which the items included in the CONTRACT are to be located will be provided by the OWNER without cost to the CONTRACTOR, and all rights-of-way and easements across private or public property required for the installation of the WORK will be obtained by the OWNER. The OWNER will make every effort to obtain easements and rights-of-way in sufficient time to allow the WORK to progress in an orderly and expeditious manner. Failure on the OWNER'S part to obtain rights-of-way and easements in sufficient time to cause no interference with the progress of the WORK will be considered as just cause for allowing extensions of time to the CONTRACTOR in accordance with the time lost because of the lack of rights-of-way and easements.

27. EXISTING UTILITIES, STRUCTURES, AND OTHER PROPERTY

- A. The position of pole lines, conduits, water mains, sewers, storm drains, natural gas lines, and other above and below ground utilities and structures is not necessarily shown on the CONTRACT drawings. Where shown, the accuracy of the position of such utilities and structures is not guaranteed. Before construction begins, the CONTRACTOR shall inform himself of the exact location of all such utilities and structures, and shall assume all liability for damaging them. Unless otherwise specified, the CONTRACTOR shall support all such utilities and structures, or temporarily remove them, and restore them to the satisfaction of the owners of the utilities and/or structures.

- B. After commencing work, the CONTRACTOR shall use every precaution to avoid interfaces with existing underground and surface utilities and structures, and to protect them from damage.
- C. The CONTRACTOR shall contact owners of underground utilities to determine the exact location of those utilities before performing any construction in the immediate vicinity of those respective utilities. Contact for relocation shall be made through the Tennessee One Call service, telephone number 1-800-351-1111. The location of the services must be requested three (3) days prior to digging.

Utility	Owner	Telephone
Gas and Electricity	Memphis Light, Gas, and Water	901-729-8600 (Hickory Hill Work Center)
Sewer and Water	Town of Collierville	901-457-2800
Cable Television	Comcast	800-351-1111
Telephone	AT&T	800-351-1111
Traffic Signal	Town of Collierville	901-853-3270
Other Telecomm. Lines		

- D. The CONTRACTOR shall repair or pay for any damage caused by his operations to all utility property, and private property whether it is above or below ground, and he shall settle in total cost all damage suits which may arise as a result of his operations.

28. EXISTING UTILITY RELOCATIONS AND/OR ADJUSTMENTS

- A. All relocations and/or adjustments required for electrical facilities, natural gas mains and service lines, and related appurtenances shall be performed by Memphis Light, Gas, and Water.
- B. Telephone lines and cables, above and below ground, shall be relocated and/or adjusted as needed by AT&T Telephone Company.
- C. Television cable lines shall be relocated and/or adjusted as necessary by Comcast.
- D. If the plans for the PROJECT provide for relocation and/or adjustment of sanitary sewer and/or related service lines and/or storm drainage facilities, the CONTRACTOR shall be responsible for performing such work at his expense.
- E. The CONTRACTOR shall cooperate fully with each of the companies named in A, B, and C above. The CONTRACTOR shall cooperate and schedule his WORK with these utilities to avoid all interference with each utility's and CONTRACTOR'S work.
- F. The charges, if any, of the companies named in A, B and C above shall be the responsibility of the OWNER and shall be paid directly by the OWNER to such companies.

29. ACCESS TO PROPERTIES DURING CONSTRUCTION

- A. Each property owner affected by the PROJECT will be provided with continuous access to his respective property. The CONTRACTOR shall plan his work so as to ensure this. When the situation requires, the CONTRACTOR shall provide signage and barricades to redirect local traffic to the appropriate detour.
- B. Failure to provide appropriate signage and barricades shall be cause for the OWNER to stop work on all activities associated with the PROJECT.

30. EROSION AND SILTATION

The CONTRACTOR shall:

- A. During PROJECT construction, use every precaution and make all provisions as required to minimize erosion and siltation, and to prevent damage to adjacent properties by erosion and siltation resulting from performance under this CONTRACT.
- B. All adjacent properties damaged by erosion and/or siltation resulting from this PROJECT shall be restored to at least pre-construction conditions by the CONTRACTOR and at his expense.
- C. The CONTRACTOR shall fully comply with all Town, County, State and Federal codes, ordinances, rules, regulations, and laws applicable to stormwater discharge, disposal and/or runoff.

31. AIR QUALITY PROTECTION

- A. General: The CONTRACTOR shall use suitable precautions to minimize air pollution during the progress of the work. The CONTRACTOR shall fully comply with all TOWN, County, State and Federal codes, ordinances, rules, regulations, and laws applicable to air pollution and/or air quality. The CONTRACTOR shall maintain all excavations, stockpiles, and all other work areas within and without the PROJECT boundaries free from dust that would cause the standards for air pollution to be exceeded, thus causing a hazard or nuisance to others. All equipment utilized for dust control shall be of safe design and/or of sufficient capacity for the intended WORK. The CONTRACTOR shall perform dust control as the WORK proceeds and when a dust hazard or nuisance occurs.
- B. Burning: No burning will be permitted.

32. PROTECTION OF THE WORK

In the event of temporary suspension of work, or during a period of inclement weather, or whenever the ENGINEER shall direct, the CONTRACTOR will protect, and will cause his SUBCONTRACTOR(S) to protect, the CONTRACTOR'S and the respective SUBCONTRACTORS' work and materials against damage or injury from the weather. If, in the opinion of the ENGINEER, any work or materials are damaged by reason of the failure of the CONTRACTOR or any of his SUBCONTRACTORS to protect said WORK or materials, such WORK or materials shall be removed and replaced at the expense of the CONTRACTOR.

33. CONTRACT SECURITY

- A. The CONTRACTOR shall furnish Performance and Payment Bonds in an amount equal to 100% of the CONTRACT price, which BONDS must remain in an amount equal to 100% of the CONTRACT price, **including any amendment thereto**, for the duration of the PROJECT, as security for the faithful performance and payment of all his obligations under the CONTRACT DOCUMENTS.
- B. The OWNER shall, in its sole discretion, have the right to waive the SURETY Bond requirements, in which case the CONTRACTOR shall reduce his bid price in the amount of the CONTRACTOR'S cost for such security.

34. WAGE RATES

The CONTRACTOR shall pay at least the minimum wage rates established by law. Such wage rates are minimum rates only, and the OWNER will not consider any claims for additional compensation made by the CONTRACTOR because of payment by the CONTRACTOR of any wage rates in excess of minimum rates, nor will the OWNER consider any claim for additional compensation made by the CONTRACTOR because of minimum wage increases established by law during the life of the CONTRACT.

35. SUBCONTRACTING

- A. The CONTRACTOR shall not award any SUBCONTRACT to any SUBCONTRACTOR without the ENGINEER'S prior approval. Only those SUBCONTRACTOR of proven ability whose reputation is known to the ENGINEER for executing first-class work will be approved. The ENGINEER'S approval will not be given until the CONTRACTOR submits to the ENGINEER an itemized written statement designating the name of each SUBCONTRACTOR and the amount of each SUBCONTRACT. This statement shall also designate the items of the CONTRACT that the CONTRACTOR proposes to execute directly with his own organization. The amount of these items, combined with the amounts of the various SUBCONTRACT proposals, shall correspond to the CONTRACT price for the entire PROJECT. The CONTRACT will not be signed until all SUBCONTRACTORS have been approved.
- B. The CONTRACTOR shall be as fully responsible to the OWNER for the acts and omissions of his SUBCONTRACTORS, and of persons either directly or indirectly employed by them, as he is for the acts and omissions of persons directly employed by him.
- C. The CONTRACTOR shall cause appropriate provisions to be inserted in all SUBCONTRACTS relative to the work to bind SUBCONTRACTORS to the CONTRACTOR by the terms of the General Provisions and other CONTRACT DOCUMENTS insofar as applicable to the work of SUBCONTRACTORS, and give the CONTRACTOR the same power to terminate any SUBCONTRACT that the OWNER may exercise over the CONTRACTOR under any provisions of the CONTRACT DOCUMENTS.

- D. Nothing contained in this CONTRACT shall create any contractual relation between any SUBCONTRACTOR and the OWNER. The contractual relationship shall exist between the OWNER and the CONTRACTOR only. It is the CONTRACTOR'S duty, in his own interest, to enter into subcontractual agreements in strict accordance with all provisions of the CONTRACT DOCUMENTS. The failure of the CONTRACTOR to make the proper agreements with his SUBCONTRACTORS and suppliers shall in no way relieve the CONTRACTOR of his responsibilities and obligations to the OWNER.
- E. The SPECIFICATIONS are grouped under the various divisions and/or sections for convenience of reference only. Each trade involved is not necessarily represented by a separate specification division and/or section, but rather, such divisions and/or sections are arbitrary and the CONTRACTOR will be permitted to allot portions of the work to SUBCONTRACTORS at his own discretion, subject to the requirements of General Provisions, Item 24, regardless of grouping of the specifications. It shall be the sole responsibility of the CONTRACTOR to settle definitely with each SUBCONTRACTOR the portion of the work that each SUBCONTRACTOR will be required to do. Neither the OWNER nor the ENGINEER will assume any responsibility whatsoever for any claims or disclaims by any of the SUBCONTRACTORS or trades concerning the responsibility for performing any particular portion of the WORK, or jurisdiction over any particular type of WORK.
- F. The CONTRACTOR and all SUBCONTRACTORS for the various branches of WORK employed on the PROJECT shall cooperate fully with each other to facilitate the progress of the WORK, and to avoid all interferences between the various parts of the WORK.
- G. Whenever his WORK is in progress, each SUBCONTRACTOR shall have present at the job site a Job Superintendent, foreman, or other duly authorized agent with authority to control the SUBCONTRACTOR's work. This duly authorized agent shall meet with the approval of the ENGINEER. The ENGINEER reserves the right to remove from the PROJECT the SUBCONTRACTOR's agent or any other employee of the SUBCONTRACTOR, if, in the ENGINEER'S judgment, such removal is necessary to protect the OWNER'S interest.

36. PAYMENTS BY CONTRACTORS

The CONTRACTOR shall pay:

1. for all transportation and utility services not later than the 20th day of the calendar month following that in which such services are rendered;
2. for all materials, tools, and other expendable equipment to the extent of ninety-five percent (95%) of cost thereof not later than the twentieth (20th) day of the calendar month following that in which such materials, tools, and equipment are delivered to the PROJECT site; and
3. to each of his SUBCONTRACTORS, not later than the fifth (5th) day following each payment to the CONTRACTOR, the respective amounts allowed the CONTRACTOR on account of the work performed by his SUBCONTRACTOR, to the extent of each SUBCONTRACTOR's interest

therein.

37. TIME FOR COMPLETION

A. DETERMINATION OF TIME FOR COMPLETION

1. For calendar day contracts, the CONTRACT time consists of the number of consecutive calendar days stated in the CONTRACT commencing on the issuance date of the Notice to Proceed and, including all Sundays, holidays and non-workdays to completion.
2. For completion date CONTRACTS, the Work must be completed on or before the fixed calendar date specified in the CONTRACT.

B. DETERMINATION OF CONTRACT TIME EXTENSIONS AND EXCUSABLE WEATHER DELAYS

1. Where the CONTRACTOR is prevented from completing any part of the WORK within the CONTRACT times due to a weather delay beyond the control of the CONTRACTOR, the CONTRACT completion time shall be extended in an amount equal to the time lost due to such delay. The CONTRACTOR shall be allowed delays for weather conditions based on the concurrence of the CONTRACTOR and ENGINEER or his designee under two circumstances: 1) isolated inclement weather, wherein the PROJECT site is determined to be unworkable for short periods time between otherwise good weather, and 2) sustained inclement weather, wherein the PROJECT site is determined to be unworkable for a sustained period of time. Under no circumstances shall the CONTRACT completion time be extended for any particular day in which there is no inclement weather making the PROJECT site unworkable.
2. If the CONTRACTOR believes either condition applies and that the conditions are delaying and/or will delay the PROJECT, the CONTRACTOR shall promptly contact the ENGINEER or his designee to request a site meeting to jointly assess the site conditions. The CONTRACTOR is strongly encouraged to maintain a rain gauge, thermometer and clock at the job site to record weather and support the delay request. If the ENGINEER or his designee determines that the site is unworkable, additional time will be added to the CONTRACT completion date. The ENGINEER'S approval or disapproval of weather delays shall be final.
3. The CONTRACTOR shall submit a formal written request for time extension of the approved weather days by the end of the month that the weather-related event occurred. Such notice shall accompany the CONTRACTOR'S pay application. The time extension request must be accompanied by an updated work schedule, particularly when the delay affects the critical path of the PROJECT.

4. The Engineer will extend the time for completion by a properly executed Change Order. Upon approval of the Change Order, the extended time for CONTRACT completion shall be in full force and effect as though it were the original time for CONTRACT completion.
5. No extra cost will be incurred by the OWNER for any extra time increase to the CONTRACT.
6. Examples of excusable weather delays include, without limitation:
 - a) Cataclysmic Natural Phenomena – Floods, fires, tornadoes, earthquakes, or other natural cataclysmic phenomenon of a nature where a Declaration of Emergency has been declared for the affected area of the Town.
 - b) Inclement Weather –Weather such as rain, ice, snow, or frozen ground, which prevents work on the PROJECT for fifty percent (50%) or more of the CONTRACTOR’S scheduled workday as determined by the ENGINEER or his designee.

C. DETERMINATION OF CONTRACT TIME EXTENSIONS AND EXCUSABLE DELAYS OTHER THAN WEATHER DELAYS

1. The TOWN will extend the CONTRACT time or completion date only if an excusable delay affects the critical path of the Work shown on the accepted work schedule. The CONTRACTOR must submit a formal written request for time extension within ten (10) consecutive calendar days of the event in question. The time extension request must include an updated work schedule with an analysis showing the impact of the delay on the critical path and documentation to support this request.
2. If the ENGINEER finds that the Work was delayed because of conditions beyond the control and without the fault of the CONTRACTOR, and the request is justified, the Engineer will extend the time for completion by a properly executed Change Order in such amount, as supported by the schedule analysis. Upon approval of the Change Order, the extended time for completion will be in full force and effect as though it were the original time for completion.
3. No extra cost will be incurred by the OWNER for any extra time increase to the CONTRACT.
4. Examples of excusable delays other than weather include, without limitation:
 - a) Utilities or Government Agencies – Delays caused by utilities or government agencies unless caused by the failure of the CONTRACTOR to cooperate and schedule his work with said utilities (Item 28 E.).
 - b) Shortage of Materials – Extraordinary and unforeseeable delays in material deliveries resulting from freight embargoes, government acts, or area wide material shortages. The request must be supported

by appropriate documentation. Poor planning and scheduling of materials shall not be considered an acceptable excuse for shortage of materials delays.

38. SUBSTANTIAL COMPLETION

- A. When the CONTRACTOR considers that the WORK, or a portion thereof is substantially complete, it is the CONTRACTOR'S responsibility to submit a written request to the PROJECT MANAGER. The request must include a "Punch List" of all items that, in the opinion of the CONTRACTOR, need to be completed or corrected prior to final acceptance. Failure to include an item on such list does not alter the responsibility of the CONTRACTOR to complete all Work in accordance with the CONTRACT DOCUMENTS.
- B. Upon receipt of the CONTRACTOR'S Punch List, the ENGINEER or the OWNER'S designee (as applicable) will review the list and completed work to determine that the list is both accurate and complete. If the inspection discloses any item, whether or not included on the CONTRACTOR'S Punch List, which is not sufficiently complete in accordance with the CONTRACT DOCUMENTS so that the OWNER can occupy or utilize the WORK or designated portion thereof for its intended use, the CONTRACTOR shall, before issuance of the Certificate of Substantial Completion, promptly complete or correct such item upon notification by the ENGINEER, or the OWNER'S designee (as applicable). The CONTRACTOR shall thereafter submit a request for another inspection by the ENGINEER or OWNER'S designee to determine Substantial Completion.
- C. When the Work or designated portion thereof is substantially complete, the ENGINEER or OWNER'S designee will prepare a Certificate of Substantial Completion, which shall establish the date of Substantial Completion, shall establish responsibilities of the OWNER and CONTRACTOR for security, maintenance, heat, utilities, damage to the Work and insurance, and shall fix the time within which the CONTRACTOR shall finish all items on the Punch List accompanying the Certificate. Warranties required by the CONTRACT DOCUMENTS shall commence on the date of Substantial Completion of the Work or designated portion thereof unless otherwise provided in the Certificate of Substantial Completion.
- D. The Certificate of Substantial Completion shall be submitted to the OWNER and CONTRACTOR for their written acceptance of responsibilities assigned to them in such Certificate. A copy of the completed Punch List signed by the OWNER'S designee and CONTRACTOR must be provided before final payment will be made.

39. PARTIAL OCCUPANCY OR USE

- A. The OWNER may occupy or use any completed or partially completed portion of the WORK at any stage when such portion is designated in accordance with the provisions herein contained, provided such occupancy or use is consented to by the insurer and authorized by public authorities having jurisdiction over the WORK. Such partial occupancy or use may commence whether or not the portion is substantially complete, provided the OWNER and CONTRACTOR have accepted in writing the responsibilities

assigned to each of them for payments, retainage, if any, security, maintenance, heat, utilities, damage to the WORK and insurance, and have agreed in writing concerning the period for correction of the WORK and commencement of warranties required by the CONTRACT DOCUMENTS. When the CONTRACTOR considers a portion substantially complete, the CONTRACTOR shall prepare and submit a Punch List to the ENGINEER or OWNER's designee (as applicable) as provided under General Provisions, Item 38.

- B. Immediately prior to such partial occupancy or use, the OWNER, the CONTRACTOR and the ENGINEER or OWNER'S designee (as applicable) shall jointly inspect the area to be occupied or portion of the WORK to be used in order to determine and record the condition of the WORK.

40. FINAL INSPECTION AND FINAL PAYMENT

- A. After the CONTRACTOR has corrected all of the items listed on the Punch List to the satisfaction of the ENGINEER or the OWNER'S designee (as applicable), the ENGINEER or the OWNER'S designee (as applicable) will notify the CONTRACTOR, in writing, that the PROJECT is accepted (i.e., the "Notice of Acceptance") and approved final payment will be made to the CONTRACTOR within thirty (30) consecutive calendar days thereafter.
- B. Accurate and complete "As Built" Drawings shall be submitted to the TOWN ENGINEER before final payment shall be made.
- C. If, after Substantial Completion of the WORK, final completion thereof is materially delayed through no fault of the CONTRACTOR or by issuance of Change Orders affecting final completion, the OWNER may, in the OWNER'S sole and absolute discretion, upon application by the CONTRACTOR without terminating the CONTRACT, make payment of the balance due for that portion of the WORK fully completed and accepted. If the remaining balance for WORK not fully completed or corrected is less than retainage stipulated in the CONTRACT DOCUMENTS, and if bonds have been furnished, the written consent of SURETY to payment of the balance due for that portion of the WORK fully completed and accepted shall be submitted by the CONTRACTOR to the ENGINEER or OWNER'S representative (as applicable) prior to certification of such payment. Such payment, if any, shall be made under terms and conditions governing final payment.
- D. The making of final payment shall not constitute a waiver of claims by the OWNER.
- E. Acceptance of final payment by the CONTRACTOR, a SUBCONTRACTOR or material supplier shall constitute a waiver of claims by that payee.

41. LIQUIDATED DAMAGES

- A. It is hereby understood and mutually agreed, by and between the CONTRACTOR and the OWNER, that the date of beginning and the time for completion as specified in the CONTRACT for the work to be done hereunder are ESSENTIAL CONDITIONS of this contract and that TIME IS OF THE ESSENCE with respect to this CONTRACT; it is

further mutually understood and agreed that the WORK embraced in this CONTRACT shall be commenced not later than a date to be specified in the "NOTICE TO PROCEED".

- B. The CONTRACTOR agrees that said WORK shall be processed regularly, diligently and uninterruptedly at such rate of progress as will ensure full completion thereof within the time specified. It is expressly understood and agreed, by and between the CONTRACTOR and the OWNER, that the time for the completion of the WORK described herein is a reasonable time for the completion of the same, taking into consideration the average climatic range and usual conditions prevailing in this locality. If the CONTRACTOR shall neglect, fail or refuse to complete the WORK within the time herein specified, or any proper extension thereof granted by the OWNER, then the CONTRACTOR does hereby agree, as a part consideration for the awarding of this CONTRACT, to pay the OWNER the amount stated in the BID per day, not as a penalty, but as liquidated damages, for such breach of CONTRACT, for each and every calendar day that the CONTRACTOR shall be in default after the time stipulated in the CONTRACT for completing the WORK.
- C. The aforesaid amount is fixed and agreed upon by and between the CONTRACTOR and the OWNER because both parties recognize that the OWNER and its citizens will suffer actual damages if the CONTRACTOR fails to complete the WORK within the time specified herein but such damages are indeterminable and difficult to measure at the time of contracting. In making their agreement regarding liquidated damages, the parties have considered, among other things: (a) that this is a public PROJECT, i.e. a PROJECT being built by the OWNER for the benefit of and use by its citizens and the public generally, and that any delay in its scheduled completion will cause damages to those persons anticipated to use the PROJECT, which will be difficult and/or impossible to measure; and (b) that the OWNER'S staff will be required to monitor the CONTRACTOR throughout the pendency of construction, and the longer that construction takes, the longer the OWNER will be required to devote the services of its personnel and, in some instances employ the services of its consultants, all at additional expense to the OWNER. The CONTRACTOR recognizes the foregoing, and agrees that the amount of liquidated damages fixed and agreed upon herein is a reasonable estimate of OWNER's potential damages made at the inception of the CONTRACT and agrees that such is not a penalty.
- D. It is further agreed that time is of the essence of each and every portion of this CONTRACT and of the SPECIFICATIONS wherein a definite and certain length of time is fixed for the performance of any act whatsoever. Where under the CONTRACT an additional time is allowed for the completion of any WORK, the new time limit fixed by such extension shall be of the essence for this CONTRACT. The CONTRACTOR shall not be charged with liquidated damages or any excess cost when the OWNER determines, in its sole discretion, that the CONTRACTOR is without fault and the CONTRACTOR'S reason(s) for the time extension are acceptable to the OWNER. The CONTRACTOR shall not be charged with liquidated damages or any excess cost when the delay of completion of the work is due:
 - 1. to unforeseeable cause beyond the control and without the fault or negligence of the CONTRACTOR; or

2. to any delays of SUBCONTRACTORS or suppliers occasioned by any of the causes specified in General Provisions, Item 41D (1) immediately above.
- E. Provided, however, that the CONTRACTOR shall, within ten (10) consecutive calendar days from the beginning of such delay, notify the OWNER in writing of the causes of the delay. The OWNER shall then ascertain the facts and extent of the delay and notify the CONTRACTOR within a reasonable time of its decision in the matter.

42. NOTICES AND SERVICE THEREOF

- A. All notices, demands, requests, instructions, approvals and claims shall be in writing.
- B. Each notice to or demand upon the CONTRACTOR shall be sufficiently given if delivered at the office of the CONTRACTOR shown by him in the BID (or at such other office as the CONTRACTOR may from time to time designate to the OWNER in writing), or sent via fax to CONTRACTOR'S fax number, or by e-mail or standard postal service, in each case addressed to such office.
- C. Unless otherwise specified in writing to the CONTRACTOR or in the BID DOCUMENTS or C&A, all papers required to be delivered to the OWNER shall be delivered to the ENGINEER, and each notice to or demand upon the OWNER shall be sufficiently given if delivered to the ENGINEER'S office or sent via facsimile transmission to the OWNER'S fax number or by e-mail or delivered standard postal service or any other common carrier. In each case, such paper shall be addressed to the ENGINEER or to such other representative of the OWNER or to such other address as the OWNER may subsequently specify in writing to the CONTRACTOR for such purposes.
- D. Each such notice or demand shall be deemed to have been given or made as of the time of actual delivery and acceptance if common carrier or hand delivered, or, in the case of fax transmissions or emails, at the time when same are properly transmitted and received by the recipient's telecommunication device(s).

43. RIGHTS OF THE OWNER TO TERMINATE CONTRACT

If the CONTRACTOR should be adjudged bankrupt, or if he should make a general assignment for the benefit of his creditors, or if a receiver should be appointed for the CONTRACTOR or any of his property, or if he should persistently or repeatedly refuse or fail to supply enough properly skilled workmen or proper material, or if he should refuse or fail to make prompt payment to persons supplying labor or material for the work under the CONTRACT, or persistently disregard instructions or fail to observe or perform any provisions of the OWNER'S instructions, or fail to observe or perform any provisions of the CONTRACT DOCUMENTS, or otherwise be guilty of a violation of any provision of the CONTRACT DOCUMENTS, then the OWNER may, by at least five (5) business days prior written notice to the CONTRACTOR, without prejudice to any other rights or remedies of the OWNER under the circumstances, terminate the CONTRACTOR'S right to proceed with the work. In such event, the SURETY shall take over the WORK and prosecute it to completion, by contract or otherwise, and the SURETY shall be liable for

all costs in excess of the CONTRACT price. In such case, the SURETY may take possession of, and utilize in completing the WORK, such materials, appliances, and plant as may be on the site of the WORK and necessary therefor. Before commencing such WORK, however, the SURETY, including any replacement contractor that may be engaged by the SURETY, must be acceptable to OWNER and fully comply with all conditions, requirements, and obligations imposed by the CONTRACT DOCUMENTS. The foregoing provisions are in addition to, and not a limitation of, the rights of the OWNER under all other provisions of the CONTRACT DOCUMENTS.

44. ASSIGNMENT OF CONTRACT

The CONTRACTOR shall not assign the whole or any part of this CONTRACT or any monies due or to become due hereunder without the OWNER'S written consent. In case the CONTRACTOR assigns all or any part of any monies due or to become due under this CONTRACT, the instrument of assignment shall contain a clause substantially to the effect that it is agreed that the right of the assignee in and to any monies due or to become due to the CONTRACTOR shall be subject to prior liens or claims of all persons, firms, and corporations for services rendered or materials supplied for the performance of the WORK called for in this CONTRACT.

45. CLAIMS FOR EXTRA COST

If the CONTRACTOR claims that any instructions by drawings or otherwise involve extra cost or an extension of time, he shall so notify the OWNER in writing within ten (10) consecutive calendar days after the receipt of such instructions, and in all cases before proceeding to execute the WORK. Thereafter, the procedure shall be the same as that described in General Provisions, Item 46, CHANGES IN WORK. No such claim shall be valid unless it is made in accordance with the terms of General Provisions, Item 46.

46. CHANGES IN WORK

- A. At any time, by a written order and without notice to the sureties, the OWNER may make changes in the drawings and specifications of this CONTRACT and within the general scope thereof. In making any change, the charge or credit for the change will be determined by the OWNER by one of the following methods prior to the issuance of the order for the changed work:
1. Method 1: The order shall fix the total lump sum value of the change, and shall establish the amount that shall be added to or deducted from the CONTRACT price. On all changes involving extras which will be added to the CONTRACT price, the price of the extras shall include the CONTRACTOR'S overhead and profit, which shall be as described in Method (4) below. On all changes that involve a new credit to the OWNER, no allowance for overhead and profit shall be figured, except as otherwise noted in Method (2) below;
 2. Method 2: If the change involves construction items for which unit BID prices are shown in the BID, the amount to be added to or deducted from

the CONTRACT price shall be determined by multiplying the unit quantities of the items to be added or omitted by the corresponding unit bid prices for the items involved, without further allowance for CONTRACTOR'S overhead and profit;

3. Method 3: If the work is performed on a unit price basis and the change involves adding construction items for which no unit prices are shown in the BID, the unit prices for the items involved shall be estimated by Method (1) above or Method (4) below, based upon cost data of similar bid items. The amount to be added to the CONTRACT price shall be determined by multiplying the unit quantities of the item to be added by this estimated unit price;
4. Method 4: Upon the OWNER'S order, the CONTRACTOR shall proceed with the work and keep and present to the OWNER, in such form as the OWNER may authorize, a correct account of the total cost of the change, together with all vouchers therefor. The total cost shall be determined as follows:
 - a) Compute the net cost of the change, which shall include direct labor and items incidental to labor, such as public liability insurance, workmen's compensation insurance, and social security; materials and sales taxes on materials; the actual use of power tools and equipment; power; and pro-rata charges for foremen.
 - b) Except as otherwise specified in General Provisions, Item 46B below, compute an allowance for overhead and profit. This allowance shall not exceed the following percentages of the net cost of the change as determined in General Provisions, Item 46A (4)a above: for all work performed, an allowance of 10% overhead and 10% profit shall be allowed; and an additional allowance of a 5% handling charge may be allowed for work performed by a SUBCONTRACTOR(S). In no case shall the 10% overhead and 10% profit be applied to any work which has previously had these allowances added, nor shall the 5% handling charge be applied to any work which is not subcontracted. The 5% handling charge may be applied to the net cost of the change plus its allowable overhead and profit. Among the items which may be considered as overhead are bond or bonds; supervision; superintendents; timekeepers; clerks; watchmen; small tools; incidental job burdens; general office expenses; and insurance other than that noted in General Provisions, Item 46A (4)a above.
 - c) The sum of the amounts computed in accordance with General Provisions, Items 46A (4)a and (4)b above shall constitute the total cost of the Change Order, except as otherwise specified in General Provisions, Item 46B below.

- B. Where a cash allowance is included in the BID for authorized Contract Amendments or other purposes, the CONTRACTOR shall include in his total bid price all overhead, profit, and handling charges on the stated amount of the allowance. On all changes in the work

which are to be paid for by this allowance, the CONTRACTOR shall not add to the net cost of the change any additional overhead and profit or any handling charges. However, if any part of such work is subcontracted, each SUBCONTRACTOR and SUB-SUBCONTRACTORS may allow himself not more than 10% overhead and 10% profit, as described in General Provisions, Item 46A (4)b above, but shall not include any handling charges.

- C. Where required by the OWNER, the CONTRACTOR shall furnish to the OWNER an itemized breakdown of the quantities and prices used in computing the value of each change that may be authorized.
- D. In figuring changes, instructions for measurement of quantities as set forth in the specifications shall be followed.
- E. During the progress of the work, should the CONTRACTOR encounter, or the ENGINEER or OWNER discover, subsurface or latent conditions at the site differing materially from those shown on the drawings or indicated in the specifications, or unknown conditions of an unusual nature differing materially from those ordinarily encountered and generally recognized as inherent in WORK of the character provided for in the drawings and specifications, the ENGINEER'S attention shall be called immediately to such conditions before they are disturbed. The ENGINEER will thereupon promptly investigate the conditions. If he finds that they do materially differ, with the written approval of the OWNER, the CONTRACT will be modified to provide for the increase or decrease of cost and difference in time resulting from such conditions.
- F. If conditions described in General Provisions, Item 46E above are encountered and the CONTRACTOR fails to notify the ENGINEER and/or proceeds to work in area(s) without written permission from the ENGINEER, the CONTRACTOR shall assume full responsibility for all work performed. All unacceptable WORK performed under these conditions shall be promptly repaired or replaced at the CONTRACTOR'S expense with no cost to the OWNER. No extra cost shall be allowed for any work performed in the area(s) described in General Provisions, Item 46E without written approval from the ENGINEER.

47. SANITARY FACILITIES

Where satisfactory sanitary facilities are not available to the job, the CONTRACTOR shall construct and maintain, at his expense, temporary toilet facilities complying with all local health department requirements and satisfactory to the ENGINEER, and shall remove them after completion of the PROJECT.

48. CUTTING AND PATCHING

- A. Generally, cutting of new construction shall be avoided wherever possible by the proper coordination between the various trades, and by the placing of proper sleeves, inserts, bolts, and other items in the construction as the WORK progresses.
- B. However, where subsequent cutting of new construction or cutting of existing construction

is required, it shall be done in a neat, careful, and approved manner, without unnecessary or extensive damage to the construction involved, and only to such an extent that is reasonably necessary for the installation of the WORK.

- C. All patching, repairing, and altering shall be done only by mechanics skilled in the various trades involved, using materials and workmanship to match those of the original construction in type and quality.
- D. All existing construction which is disturbed or damaged in any way by the CONTRACTOR'S operations shall be restored at least to the conditions which existed before WORK was begun, unless otherwise indicated.

49. REMOVAL OF DEBRIS / CLEAN UP

- A. During the progress of the WORK, the CONTRACTOR shall remove and properly dispose of the resultant dirt and debris and keep the premises reasonably clear thereof. Upon completion of the WORK the CONTRACTOR shall: remove all construction equipment and unused materials provided for the WORK; put all the buildings, structures, and premises in a neat and clean condition; and do all cleaning and washing required by the SPECIFICATIONS, BID DOCUMENTS, or C&A.
- B. In addition to the requirements of General Provisions, Item 49A, the site and structures to be constructed thereon shall be maintained and kept clean and free of rubbish, unused materials, and equipment during the construction period. The CONTRACTOR shall remove all dirt, rubbish, and surplus materials of all descriptions, including equipment not in use, and maintain the site in a neat and orderly condition, all as approved by the OWNER in its sole discretion. Materials and equipment known to belong to others shall not be removed from the site without duly notifying the owner thereof.

50. USE OF COMPLETED WORK

- A. The ENGINEER may accept a section or sections of a PROJECT before the entire PROJECT is completed. Such section(s) shall be of reasonable size, as determined by the ENGINEER, and shall be completed in full accordance with the Plans, Specifications and all other applicable provisions of the CONTRACT. No section(s) shall be accepted unless the CONTRACTOR has received payment of at least 95% of the value of the WORK from the OWNER. The acceptance of a section or sections of a PROJECT shall in no way void or alter any of the terms of the CONTRACT.
- B. Upon written request to the CONTRACTOR, the OWNER may elect to place any one or more of the approved completed portions of the WORK in operation, in which event the OWNER shall assume complete and sole responsibility for those portions of the WORK covered in the written request; provided, however, that nothing contained herein shall relieve the CONTRACTOR of any liability with respect to defective workmanship and materials as provided for under General Provisions, Item 54, GUARANTEE, below.

51. STARTING, TESTING, AND ADJUSTING

Upon substantial completion of all WORK under this CONTRACT and after the ENGINEER'S preliminary inspection thereof, the CONTRACTOR shall maintain one or more qualified competent workers on the job as required: to put the PROJECT in operation; to conduct all specified tests (see General Provisions, Item 52); to make all necessary corrections and adjustments to obtain specified, indicated, and satisfactory operation; and if a trial run is specified in SPECIAL CONDITIONS or the SPECIFICATIONS, to cooperate with, assist, and instruct the OWNER's representatives during the required trial run. Failure of the CONTRACTOR to comply with this requirement of the CONTRACT shall be considered just cause for delaying final approval and acceptance of the WORK, delaying the commencement of the guarantee period, and withholding any and all funds which may then be due the CONTRACTOR.

52. LABORATORY TESTING

- A. The OWNER shall, at its own expense, make arrangements for laboratory testing services specified for concrete work, paving materials, and base course, and the cost of laboratory inspection, and stamping of pipe, fittings, equipment and other materials.
- B. The OWNER may, at its own expense, make arrangements for any additional testing services that it may deem appropriate. Tests conducted on behalf of the OWNER shall in no way release the CONTRACTOR of his responsibility to provide a quality product meeting the specification requirements for materials and workmanship of the PROJECT.
- C. Should work provided by the CONTRACTOR fail any laboratory tests or if the CONTRACTOR schedules testing but the work is not ready for testing when the laboratory technician arrives on-site, the CONTRACTOR shall be responsible for the expense of all re-tests and/or trip charges.

53. TAXES

The CONTRACTOR shall pay all applicable Federal, State and Local taxes and shall include the total amount of the taxes in the BID price.

54. GUARANTEE

- A. All labor and material furnished by the CONTRACTOR covered by the drawings and specifications and official modifications thereof shall be guaranteed by the CONTRACTOR for a period of one (1) year from the date of substantial completion of the completed PROJECT. CONTRACTOR shall notify OWNER of any warranties on components lasting longer than one (1) year.
- B. CONTRACTOR shall also provide a one (1) year guarantee with respect to required landscaping, foliage, flowers, trees, and the like from the date of acceptance by the OWNER of said landscaping, foliage, flowers, trees, and the like. To the extent that such landscaping, foliage, flowers, trees, and the like must be replaced by CONTRACTOR hereunder, CONTRACTOR shall likewise provide an additional one (1) year guarantee from the time of said replacement.

1. During the one (1) year guarantee period, where trees, shrubs, bushes, grass seed and/or sod, and the like have been planted, the CONTRACTOR shall inspect and monitor the plantings monthly to confirm life, vigorous growth and the absence of pests and disease. The CONTRACTOR shall provide a monthly report of findings to the OWNER. The OWNER shall corroborate such report(s) by periodic inspection and any such planting determined by the OWNER to be dead, dying, diseased or pest infested must be replaced by CONTRACTOR hereunder, and CONTRACTOR shall likewise provide an additional one (1) year guarantee from the time of said replacement.
- C. All necessary repairs required during this period due to defective workmanship or material shall be made promptly by the CONTRACTOR without cost to the OWNER at times convenient to the OWNER. An additional one (1) year guarantee period from the date of acceptance of the repaired item by the OWNER shall apply to any such repaired item.
- D. The ENGINEER shall have the sole right to establish the beginning of the guarantee period for all portions of the PROJECT, and if so stated in the SPECIAL CONDITIONS or the SPECIFICATIONS, the guarantee period shall not begin until a trial run has been completed with satisfactory operation, to be determined in the sole discretion of the OWNER, for the period of time stated in the SPECIAL CONDITIONS or the SPECIFICATIONS. It shall be the CONTRACTOR'S duty to make all final adjustments, perform all miscellaneous clean-up work, and conduct all specified performance tests. Final acceptance will not be given until the completion of all final adjustments, clean-up work, and tests.
- E. Where certain portions of the PROJECT are placed in use before the entire PROJECT is completed, the guarantee period for the equipment or items placed in use shall begin prior to the acceptance date of the entire PROJECT.

55. SAFETY AND HEALTH REGULATIONS

- A. The CONTRACTOR shall comply with the Department of Labor Safety and Health Regulations for construction promulgated under the Occupational Safety and Health Act of 1970 (PL 91-596) and under Section 107 of the Contract Work Hours and Safety Standards Act (PL 91-54).
- B. Authorized representatives of the Department of Labor and TOWN Safety Representative(s) shall be permitted free access to the PROJECT for inspections.

56. ARCHITECTURAL PROVISIONS

The following provisions shall be applicable in the event that a licensed ARCHITECT is involved with the PROJECT:

- A. The drawings, specifications and other documents prepared by the ARCHITECT are instruments of the ARCHITECT'S service through which the WORK to be executed by the CONTRACTOR is described. The CONTRACTOR may retain one CONTRACT

record set. Neither the CONTRACTOR nor any SUBCONTRACTOR, SUB-SUBCONTRACTORS or material or equipment supplier shall own or claim a copyright in the drawings, specifications and other documents prepared by the ARCHITECT, and unless otherwise indicated, the ARCHITECT shall be deemed the author of them and will retain all common law, statutory and other reserved rights, in addition to the copyrights. All copies of the drawings, except the CONTRACTOR's record set, shall be returned or suitably accounted for to the ARCHITECT, on request, upon completion of the WORK. The drawings, specifications and other documents prepared by the ARCHITECT, and copies thereof furnished to the CONTRACTOR are for use solely with respect to this PROJECT. They are not to be used by the CONTRACTOR or any SUBCONTRACTOR, SUB-SUBCONTRACTORS or for additions to this PROJECT outside the scope of the WORK without the specific written consent of the OWNER and ARCHITECT. The CONTRACTOR, SUBCONTRACTORS, SUB-SUBCONTRACTORS and material or equipment suppliers are granted a limited license to use and reproduce applicable portions of the drawings, specifications and other documents prepared by the ARCHITECT appropriate to and for use in the execution of WORK under the CONTRACT DOCUMENTS. All copies made under this license shall bear the statutory copyright notice, if any, shown on the drawings, specifications and other documents prepared by the ARCHITECT. Submittal or distribution to meet official requirements or for other purposes in connection with this PROJECT is not to be construed as publication in derogation of the ARCHITECT'S copyright or other reserved rights. PROVIDED, HOWEVER, that notwithstanding any provision in this Section 56A to the contrary, it is understood and agreed that the OWNER shall be the owner of all drawings, specifications, and other documents prepared by the ARCHITECT for this PROJECT and that the OWNER may make any use of same as is lawful.

- B. The ARCHITECT will not have control over or charge of and will not be responsible for construction means, methods, techniques, sequences or procedures, or for safety precautions and programs in connection with the WORK, since these are solely the CONTRACTOR'S responsibility. The ARCHITECT will not be responsible for the CONTRACTOR'S failure to carry out the WORK in accordance with the CONTRACT DOCUMENTS. The ARCHITECT will not have control over or charge of and will not be responsible for acts or omissions of the CONTRACTOR, SUBCONTRACTORS, or their agents or employees, or of any other persons performing portions of the WORK.
- C. The ARCHITECT will have authority to reject WORK, which does not conform to the CONTRACT DOCUMENTS. Whenever the ARCHITECT considers it necessary or advisable for implementation of the intent of the CONTRACT DOCUMENTS, the ARCHITECT will have authority to require additional inspection or testing of the WORK whether or not such WORK is fabricated, installed or completed. However, neither this authority of the ARCHITECT nor a decision made in good faith either to exercise or not to exercise such authority shall give rise to a duty or responsibility of the ARCHITECT to the CONTRACTOR, SUBCONTRACTORS, material and equipment suppliers, their agents or employees, or other persons performing portions of the WORK.
- D. The ARCHITECT will review and approve or take other appropriate action under the CONTRACTOR'S submittals such as shop drawings, product data and samples, but only

for the limited purpose of checking for conformance with information given and the design concept expressed in the CONTRACT DOCUMENTS. The ARCHITECT'S action will be taken with such reasonable promptness as to cause no delay in the WORK or in the activities of the OWNER, CONTRACTOR or separate contractors, while allowing sufficient time in the ARCHITECT'S professional judgment to permit adequate review. Review of such submittals is not conducted for the purpose of determining the accuracy and completeness of other details such as dimensions and quantities, or for substantiating instructions for installation or performance of equipment or systems, all of which remain the responsibility of the CONTRACTOR as required by the CONTRACT DOCUMENTS. The ARCHITECT'S review shall not constitute approval of safety precautions or, unless otherwise specifically stated by the ARCHITECT, of any construction means, methods, techniques, sequences or procedures. The ARCHITECT'S approval of a specific item shall not indicate approval of an assembly of which the item is a component.

- E. The ARCHITECT will interpret and decide matters concerning performance under the requirements of the CONTRACT DOCUMENTS on written request of either the OWNER or CONTRACTOR. The ARCHITECT'S response to such requests will be made with reasonable promptness and within any time limits agreed upon.
- F. Interpretations and decisions of the ARCHITECT will be consistent with the intent of and reasonably inferable from the CONTRACT DOCUMENTS and will be in writing or in the form of drawings. When making such interpretations and decisions, the ARCHITECT will endeavor to secure faithful performance by both OWNER and CONTRACTOR, will not show partiality to either and will not be liable for results of interpretations or decisions so rendered in good faith.

57. MODIFICATIONS TO GENERAL PROVISIONS

Modifications to these GENERAL PROVISIONS, if any, shall be as specified in SPECIAL CONDITIONS.

[END OF GENERAL PROVISIONS]

SPECIAL CONDITIONS

This project is a Division of Water Resource (DWR) Stream and Wetland Restoration Grant State Water Infrastructure Grant (SWIG) and must have the required Identification Signage posted as per specifications reflected on Attachment J of the bid specifications.



TOWN OF COLLIERVILLE

GENERAL SERVICES DEPARTMENT
500 POPLAR VIEW PARKWAY
COLLIERVILLE, TENNESSEE 38017

**SHELTON RD. WWTP OXIDATION DITCH ROTOR
REPLACEMENT SCOPE AND SPECIFICATIONS**

SHELTON RD. WWTP OXIDATION DITCH ROTOR REPLACEMENT

1. PROJECT SCOPE

The Work of this contract includes removal of two existing oxidation ditch brush rotors and associated accessories and site-specific replacement with two new oxidation ditch rotors. The Shelton Rd. WWTP, located at 136 E. Shelton Rd. has two oxidation ditches with eight PASSAVANT brush rotors in total.

Rotors scheduled for replacement include one 24' brush rotor with 36'-0" aerator bridge (rotor #4 in Oxidation Ditch #1) and one 24'-0" brush rotor with 34'-0" aerator bridge (rotor #1 in Oxidation Ditch #2). Following removal, the existing brush rotors will be stored onsite at the Shelton Rd. Wastewater Treatment Plant in an area designated by the Town.

The new brush rotors will be in-kind replacements and include all associated accessories and controls required to ensure functionality of the new rotors based on the existing configuration of the two oxidation ditches.

2. GENERAL

- 2.1. The Contractor will supply all necessary labor and materials required to successfully complete the project.
- 2.2. All work shall be completed during normal business hours Monday through Friday between the hours of 7:00 AM and 5:00 PM. Any work performed outside normal business hours must have prior approval from the Town representative.
- 2.3. The Contractor shall designate a representative who will be available to respond to emergency calls by the Town's representative at any time day and night and on weekends and holidays should such a situation arise during the contract period.
- 2.4. The Contractor shall, at its own expense, handle and haul all materials furnished by it and shall remove any of its surplus materials at the completion of the work.
- 2.5. The Contractor will be responsible for performing all required electrical work and permitting required to supply and install electrical conduit, wire, remote controls, and fasteners required for operation of the new replacement brush rotors. All electrical work shall be performed by a licensed electrician.
- 2.6. The Contractor will provide any required rotor controls and ensure efficient operation in conjunction with existing rotors and rotor controls at the plant.

3. NEW BRUSH ROTOR REQUIREMENTS

- 3.1. Rotors must be constructed from corrosion-resistant materials, such as stainless steel or coated alloys, suitable for long-term operation in a wastewater environment. Material specification must be verified through presentation of material certifications and testing for corrosion resistance.
- 3.2. Rotor design should allow for ease of maintenance, with rotor components easily accessible and replaceable, and requiring no more than 8 hours of downtime per year for routine maintenance.
- 3.3. Rotors should operate at a noise level not exceeding 85 decibels (dB) at a distance of 1 meter to minimize environmental and community impact.

SHELTON RD. WWTP OXIDATION DITCH ROTOR REPLACEMENT

- 3.4. Rotors must maintain consistent performance under varying influent load conditions, including peak flow scenarios, without compromising treatment efficiency.
- 3.5. The Contractor shall provide Town with all data and documentation necessary for Tennessee Department of Environment and Conservation (TDEC) approval.
- 3.6. Rotors must comply with occupational safety standards, including OSHA regulations, to ensure safe operation and maintenance for plant personnel.
- 3.7. Rotors shall include clear procedures for emergency shutdown and isolation in case of malfunction.
- 3.8. New replacement rotors must meet the existing physical dimensions of the oxidation ditches to minimize any required modifications to the oxidation ditches during installation.
- 3.9. Contractor will ensure new rotors are compatible with existing rotors and configuration (existing rotor bid specifications listed in Attachment A. for reference).
- 3.10. The new rotors provided should have a useful service life of no less than 20 years under normal operating conditions if maintained per manufacturer recommendations.

4. ROTOR PERFORMANCE REQUIREMENTS

- 4.1. With all rotor assemblies operating in a given basin, each rotor assembly (one drive) shall be capable of efficient operation based on the new rotor and existing efficiency curves.

Existing Rotor Efficiency Curves:

SPEED (rev/min)	SUBMERGENCE	LBS/O ₂ /HR/FT	HP/FT
72	6"	2.60	0.85
72	8"	3.60	1.15
72	10"	4.45	1.40
72	12"	5.60	1.65

New Rotor Efficiency Curves: *(table to be completed in by bidder on bid form)*

SPEED (rev/min)	SUBMERGENCE	LBS/O ₂ /HR/FT	HP/FT
	6"		
	8"		
	10"		
	12"		

The oxygenation data is based on tap water testing at standard conditions. The horsepower listed shall be at the motor output shaft and shall include the gear losses.

- 4.2. At the designated normal submergence, the four rotors (three existing and bidder's/new rotor) in each basin shall be capable of imparting a velocity of at least one (1) foot per second to the volume of water in the oxidation ditch.
- 4.3. When one rotor in a ditch is out of service, the remaining three rotors (two existing and bidder's/new rotor) in that ditch shall be able to maintain a liquid velocity of at least one (1) foot per second by increasing the submergence.

SHELTON RD. WWTP OXIDATION DITCH ROTOR REPLACEMENT

5. EXISTING OXIDATION DITCH ROTOR MANUFACTURER INFORMATION

5.1. Ditch #1 Rotor Information:

Manufacturer - PASSAVANT

Year of fabrication - 1979

(4 each) Bridge Mounted 5300 Series Mammoth Rotors (24' Rotors)

Serial #: 79-67-19 / 79-67-20 / 79-67-21 / 70-67-22 (4 Rotors)

5.2. Ditch #2 Rotor Information:

Manufacturer - PASSAVANT

Year of fabrication - 1987

(4 each) Bridge Mounted 5300 Series Mammoth Rotors (24' Rotors)

Serial #: 87-67-043 / 87-67-044 / 87-67-045 / 87-67-046 (4 Rotors)

6. PROSECUTION OF THE WORK

The Contractor shall have all the necessary tools and components to perform the contracted work. The Town will not supply the Contractor with tools or equipment to complete this Work. The Contractor shall prosecute in such a manner and with such a supply of materials, equipment and labor as is considered necessary to insure completion of the work in accordance with the progress schedule.

7. SITE INSPECTION

Any Contractor that wishes to inspect the existing rotors, oxidation ditch and site shall contact Donal Davis at (901) 457-2833 or (901) 457-2800 to schedule an appointment between the hours of 7:00 AM and 3:00 PM.

8. WORKMANSHIP

Where not more specifically described in any of the various sections of these specifications, workmanship shall conform to all of the methods and operations of best standards and accepted practices of the trade or trades involved, and shall include all items of fabrication, construction or installation regularly furnished or required for completion of the services. Personnel skilled in their respective lines of work shall execute all work.

9. EXECUTION

9.1. INSPECTION

9.1.1. Inspect all equipment upon arrival at job site and prior to installation. Notify the manufacturer of any damage and/or shortage

9.1.2. Inspect concrete mounting pads and anchor bolts for correct size and alignment prior to installation.

9.2. PREPARATION

9.2.1. Make corrections and/or repairs as required for items inspected and found to be deficient.

9.3. INSTALLATION

9.3.1. Install rotors and accessories in strict accordance with the manufacturer's instructions.

SHELTON RD. WWTP OXIDATION DITCH ROTOR REPLACEMENT

9.4. FIELD QUALITY CONTROL

9.4.1. The manufacturer's field engineer or representative shall inspect and check the installation after construction and be on hand for the initial start-up of the equipment for a period of at least five days. He shall also instruct treatment plant personnel in the operation and maintenance of the installed system.

9.5. ADJUSTING AND CLEANING

9.5.1. Adjust the equipment as required and within limits of manufacturer's instruction for proper alignment.

9.5.2. Apply proper type and quantity of lubricants for short term storage or start-up operation as applicable.

9.5.3. Clean equipment of any foreign matter or substances.

9.5.4. Field paint all components as required. New rotor color shall match existing rotors: Pitthane Semi-gloss Part A # 95-8800/01 Cream Color

10. REFERENCES

The manufacturer shall provide a current installation list demonstrating that their equipment is performing satisfactorily in at least ten (10) sewage treatment plants. Satisfactory performance is defined as meeting the process requirements for oxygen transfer and mixing, as well as satisfying the customer's standards for mechanical reliability. Bidder must furnish with its bid the required information as detailed on the attached reference sheet.

11. SUBMITTALS

11.1. Furnish data required by Equipment Prequalification Requirements in accordance with schedule given therein.

11.2. Furnish shop drawings and other pertinent data to the Town representative and obtain approval before fabrication.

11.3. At least one month before installation of this work, submit six (6) copies of operation and maintenance instructions to the Town representative.

12. SAFETY REQUIREMENTS

The Contractor shall be responsible for initiating, maintaining and supervising all safety precautions and programs in connection with the performance of the Contract. All safety equipment necessary to comply with all Federal, State and OSHA requirements shall be provided.

13. DELIVERY, STORAGE AND HANDLING

13.1. Deliver, store and handle items of equipment in a manner that will prevent any damage.

13.2. Follow manufacturer's instruction for short term and long-term storage, particularly with respect to proper lubricants and periodic rotation of shafts and bearings.

13.3. Touch up shop paint to prevent corrosion.

SHELTON RD. WWTP OXIDATION DITCH ROTOR REPLACEMENT

14. EQUIPMENT READINESS

The installed units shall be completely assembled and adjusted, and all equipment including standard and supplemental equipment shall be installed and the unit made ready for continuous operation.

15. FINAL INSPECTION

The Town shall make final inspection of all work included in the contract, any portion thereof, and/or any repair contract that results from the inspection, as soon as practicable after notification by the Contractor that the work is complete and ready for acceptance. If the work is not acceptable to the Town at the time of such inspection, the Contractor shall be informed in writing as to the particular defects to be remedied before final acceptance can be made.

16. WARRANTY

The bidder warrants the products and service furnished to be of the highest quality, complying with specifications and free from all defects in materials and workmanship for a minimum period of one (1) year from date of final acceptance by the Town of Collierville. Warranty terms given in the attached purchase/services contract will govern this bid. However, bidder may attach a sample of its general warranty information for consideration.

END OF SECTION



TOWN OF COLLIERVILLE

GENERAL SERVICES DEPARTMENT
500 POPLAR VIEW PARKWAY
COLLIERVILLE, TENNESSEE 38017

CONSTRUCTION DRAWINGS/ATTACHMENTS

SECTION 11375
ROTOR AERATORS

PART 1 - GENERAL

1.01 WORK INCLUDED

- A. Provision and installation of four (4) bridge mounted rotor aerator assemblies as shown on the plans and as specified herein.
- B. Provision and installation of two (2) adjustable effluent weirs as shown on the plans and as specified herein.

1.02 RELATED REQUIREMENTS

- A. Equipment Prequalification Requirements
- B. General Conditions
- C. Section 01340: Shop Drawings, Product Data and Samples
- D. Section 09900: Painting
- E. Section 13620: Operating and Monitoring System
- F. Section 26000: Electrical

1.03 SYSTEM DESCRIPTION

A. Performance:

With all rotor assemblies operating in a given basin as defined by the contract documents, each rotor assembly (one drive) shall be capable of performing according to the submergence-oxygen-horsepower table below:

SUBMERGENCE	LBS/O ₂ /HR/FT	HP/FT
6"	2.60	0.85
8"	3.60	1.15
10"	4.45	1.40
12"	5.60	1.65

The oxygenation data are based on tap water testing at standard conditions.

The horsepower listed above shall be at the motor output shaft and shall include the gear losses.

At the designated normal submergence the four rotors in each basin shall be capable of imparting a velocity of at least one (1) foot per second to the volume of water in

the oxidation ditch. When one rotor in a ditch is out of service, the remaining three rotors in that ditch shall be able to maintain a liquid velocity of at least one (1) foot per second by increasing the submergence.

1.04 QUALITY ASSURANCE

A. Manufacturer's Qualifications

1. The manufacturer shall submit as a part of the Equipment Prequalification Requirements certified reports of full-scale performance tests conducted in oxidation ditches of size and shape similar to that shown on the plans. These reports shall show that the manufacturer's equipment is capable of exceeding the performance required at this facility.
2. The manufacturer shall submit a current installation list indicating that his equipment is giving satisfactory performance at at least 20 sewage treatment plants. Satisfactory performance shall mean meeting the process requirements for oxygen transfer and mixing and meeting the Engineer's opinion of mechanical reliability.

1.05 SUBMITTALS

- A. Furnish data required by Equipment Prequalification Requirements in accordance with schedule given therein.
- B. Furnish shop drawings and other pertinent data to the Engineer and obtain his approval before fabrication.
- C. At least one month before installation of this work, submit six (6) copies of operation and maintenance instructions to the Engineer.

1.06 DELIVERY, STORAGE AND HANDLING

- A. Deliver, store and handle items of equipment in a manner that will prevent any damage.
- B. Follow manufacturer's instructions for short term and long term storage, particularly with respect to proper lubricants and periodic rotation of shafts and bearings.
- C. Touch up shop paint to prevent corrosion.

1.07 COORDINATION

- A. Coordinate this work with the work of other trades to avoid interferences and to provide for timely installation.

1.08 WARRANTY

- A. See General Conditions

PART 2 - PRODUCTS

2.01 ROTOR AERATORS

- A. Acceptable Manufacturers: Passavant Corporation, or approved equivalent.
- B. Equipment:

1. General: Furnish four (4) complete, identical bridge mounted rotor aerators as specified herein and as shown on the drawings. Each shall consist of a 24 foot long rotor assembly, shafts, bearings, gear box, drive assembly, seal plates, anchor bolts, indicated spare parts and any other accessories required for a complete installation.
2. Rotor Assembly: The supporting Bridge shall be designed to span the aeration race in accordance with the contract drawings. The supports for suspending the rotor beneath the walkway shall be of rugged construction and shall withstand all torques and loads without permanent distortion or excessive vibration. Integral with said supporting structure shall be four corner legs and feet extending below the rotor assembly whereby the entire unit can be supported during shipment and during storage and installation.

Each Rotor length shall consist of a horizontal drive shaft of 14 inch diameter high strength seamless pipe, of 3/8" minimum wall thickness, enclosed by a flanged connection on each end. End flanges shall be machined parallel to each other in a lathe following all welding on the pipe. The bearing end of each rotor length shall have a cast hub and shaft extension bolted thereto preventing liquid from entering the pipe.

Indexing means on the machined flange shall maintain the shaft extensions concentric with the rotor pipe. Each end shall be provided with clamped-on steel splash protection plates of approximately 48" diameter.

A number of 12-blade rows of aeration blades shall be assembled on the pipe. Each blade shall be formed of 11 gauge low carbon mild steel, measuring approximately 3 inches wide by 12 inches effective

aerating length, and shall have an auxiliary fabricated support to prevent blade fatigue. The forming of the blades shall include two longitudinal ribs for added stiffness and prevention of fatigue. The blades shall be hot dipped galvanized, and the assembly hardware shall be of Grade 8 plated steel bolts and locknuts which are precision compressed for vibration proof attachment. The rotor assembly, complete with all blades attached, shall have an overall diameter of approximately 39-3/8" exclusive of the 48" splash plates. The length of each rotor section shall be 24 feet.

The aeration blades shall be positioned in such a manner that successive rows of blades are offset circumferentially in a uniform spiral pattern to prevent, essentially, any two blades from simultaneously striking the water. Only clamping of the rows of blades to the torque tube shall be permitted; no welding shall be allowed between end flanges for blades or blade fasteners.

2. Outside Bearing Assemblies: A total of one (1) for each rotor assembly shall contain two cylindrical roller bearings, a bearing housing, bearing insert, saddle, internal face seals with an external labyrinth-type flinger especially designed for this service. It shall be oil lubricated and be capable of continuous service for four months without oil change.

The housing, insert and saddle shall cooperate to compensate for any axial misalignment caused by foundation movements up to 1.5 degrees from normal. It shall allow up to one (1) inch of axial shaft movement in either direction. The entire assembly shall perform a self-aligning function. Each bearing shall have a minimum L-10 life rating exceeding 200,000 hours.

Covers shall be provided for all rotor bearings. Two brackets shall be permanently attached to the bearing sole plate, with the anchor bolts therefor; a friction-fit hood shall be readily removable with two hand holds for lifting.

3. Torsion Couplings: A total of one (1) on each rotor shall be mounted on the gear output shaft and shall be bolted directly to the rotor end flange with an index fit. Each coupling shall be capable of supporting the weight of the end of the rotor and the radial loads occurring during start-up and operation of the rotor

as well as transmitting the torque necessary to drive the rotor assembly. Each shall be capable of absorbing and dampening possible shock loads. Each coupling shall be capable of meeting these requirements under conditions of 1.5 degrees of misalignment of the rotor axis.

4. Drive Assembly: Each drive assembly shall consist of a gear reducer, motor mount, drive coupling and electric motor for 72 RPM operation of the rotor.
5. Motor: Each unit shall be driven by a 40 HP 460 volt, 3 phase, 60 hertz motor with a 1.0 service factor. It shall be of vertical, flange mounting design. It shall be of TEFC enclosure especially designed for aerator service. A local ON-OFF pushbutton station shall be provided for each rotor.
6. Anchor Bolts: All anchor bolts shall be galvanized steel and furnished by the manufacturer and set with proper projection by the Contractor in accordance with approved, certified drawings furnished by the manufacturer.
7. Painting: All painting shall be in accordance with Section 09000. The contractor shall be responsible for the compatibility of shop primer with the field coat.

2.02 ADJUSTABLE EFFLUENT WEIR

- A. General: The contractor shall furnish, install and place into operation two motorized adjustable weirs two (2) adjustable effluent weirs as shown on the plans. Weirs shall be compatible with the rotors, so that rotors can be operated over their full range. Each weir shall have a gear motor-screw shaft assembly, supported in a framework for changing the elevation of the weir plate. The total vertical displacement of the crest of the weir shall 9 inches.

The assembly shall be comprised of a weir frame, weir plate, seals, hinges, linkages, screw-nut combination, drive support stand, gearmotor, limit switches, and pushbutton station. A housing shall enclose the screw-nut and the limit switches. The effective length of each weir plate shall be 24 feet.

The frame and plate shall be fabricated of mild steel, while the hinges are a butt-type design and carbon steel. The seal at both ends of the weir plate and across the bottom edge shall be neoprene. Anchor bolts shall be cadmium plated.

Connecting links between the weir and the operating screw shall be mild steel; pins and bolts applied to all movable connections shall be stainless steel. The operating screw-nut combination and the drive/screw support stand shall be mild steel.

The gearmotor shall be positioned atop the support stand with the vertical output shaft in-line and connected to the screw.

All brackets, fasteners, anchor bolts and similar items necessary to secure the furnished equipment in the tank shall be provided by the equipment manufacturer.

- B. Electrical: The reversible motor shall be 1/3 HP for 460 Volt, 3 phase, 60 Hertz AC.

A pushbutton station for operating the motor in either direction shall be furnished for installation, preferably within sight of the weir. Provisions shall be included whereby the limit switches may be interconnected to prevent over-travel in either direction. A schematic shall be furnished.

All electrical conduit, wire, remote controls and fasteners shall be provided by the contractor.

- C. Painting: All ferrous metal fabricated parts shall be coated with one shop coat of rust inhibitor primer, applied immediately following shop blasting. The gearmotor and limit switches shall be as finish coated by the manufacturer.

PART 3 - EXECUTION

3.01 INSPECTION

- A. Inspect all equipment upon arrival at job site and prior to installation. Notify manufacturer of any damage and/or shortage.
- B. Inspect concrete mounting pads and anchor bolts for correct size and alignment prior to installation.

3.02 PREPARATION

- A. Make corrections and/or repairs as required for items inspected and found to be deficient.

3.03 INSTALLATION

- A. Install rotors, weirs and accessories in strict accordance with the manufacturer's instructions.

3.04 FIELD QUALITY CONTROL

- A. The manufacturer's field engineer or representative shall inspect and check the installation after erection and be on hand for initial start-up of the equipment for a period of at least five days. He shall also instruct treatment plant personnel in the operation and maintenance of the system.

3.05 ADJUSTING AND CLEANING

- A. Adjust equipment as required and within limits of manufacturer's instructions for proper alignment.
- B. Apply proper type and quantity of lubricants for short term storage or start-up operation as applicable.
- C. Clean equipment of any foreign matter or substances.
- D. Field paint all components to be painted in accordance with Section 09000.

3.06 PROTECTION

- A. After installation and painting protect the equipment from any damage by work of other trades. Repair any damage that nevertheless occurs.

END OF SECTION

Attachment B. (Project Site Location)



Shelton Rd.

Peterson Lake Rd.

Shelton Rd. WWTP
136 E. Shelton Rd.

Shelton Rd.

Collierville-Arlington Rd.

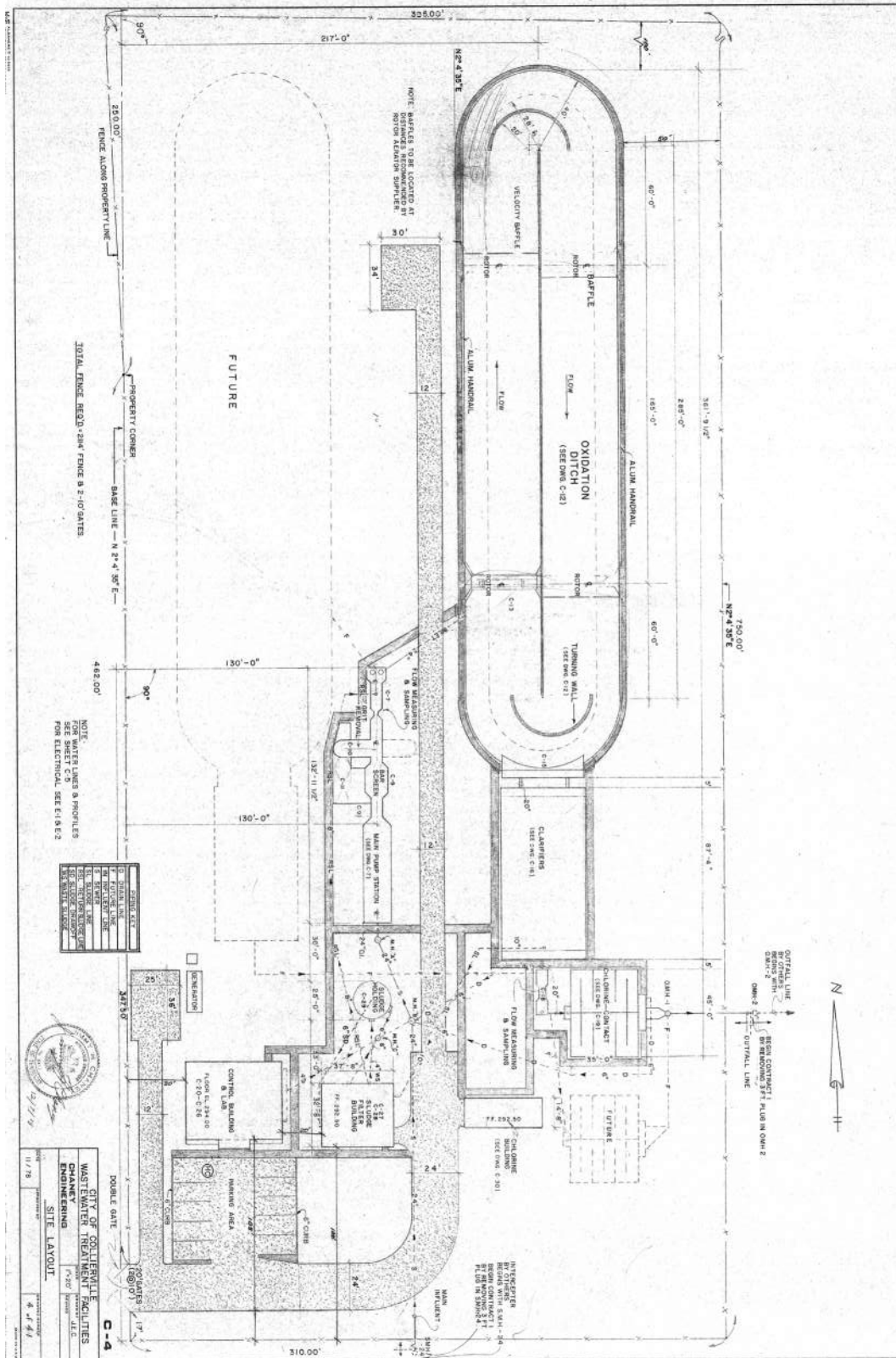

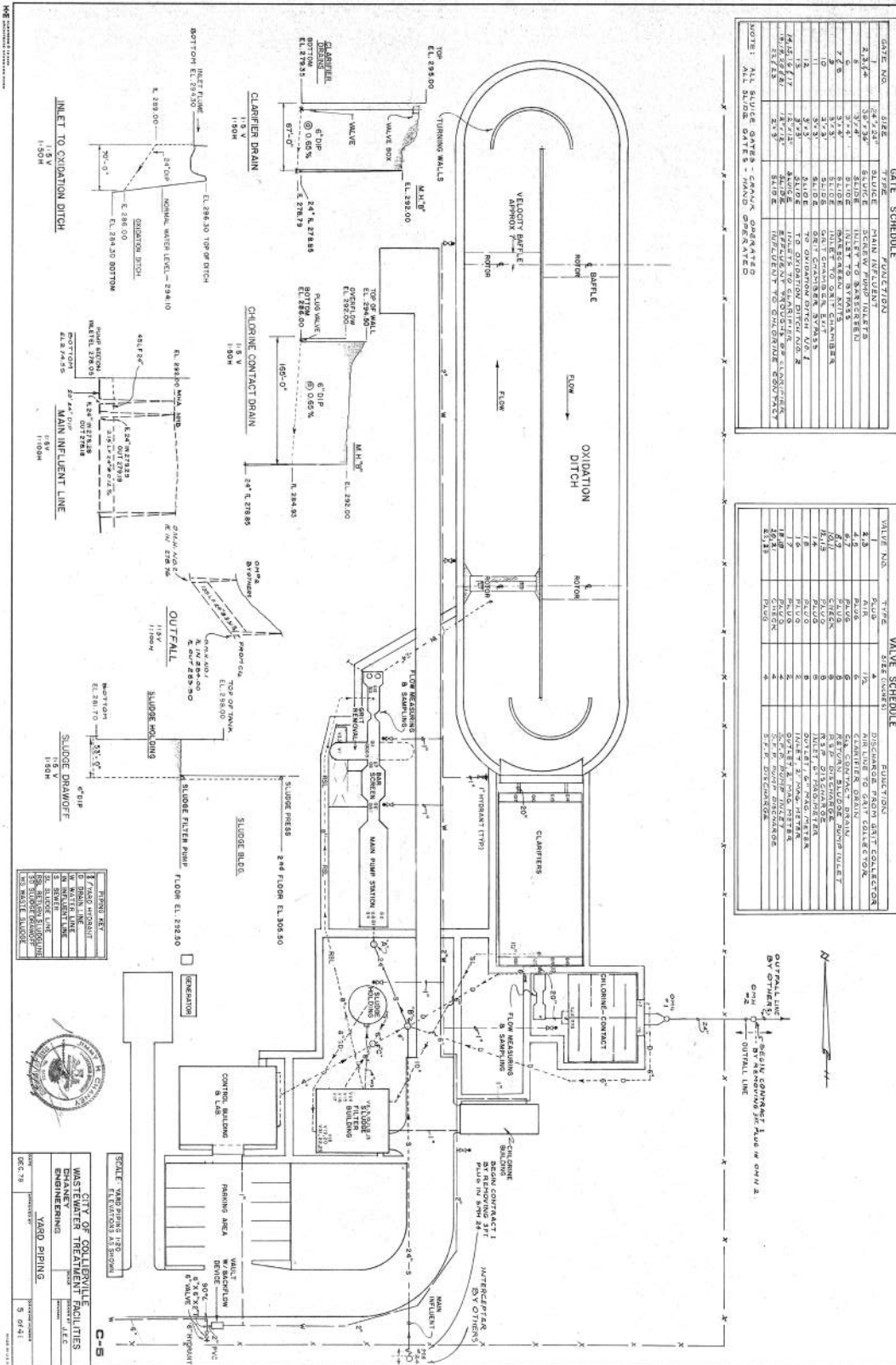

GATE SCHEDULE

GATE NO.	SIZE	TYPE	MANUFACTURER
2.1.1	36" x 24"	SLUICE	SCREW WORM DRIVE
2.1.2	36" x 24"	SLUICE	SCREW WORM DRIVE
2.1.3	36" x 24"	SLUICE	SCREW WORM DRIVE
2.1.4	36" x 24"	SLUICE	SCREW WORM DRIVE
2.1.5	36" x 24"	SLUICE	SCREW WORM DRIVE
2.1.6	36" x 24"	SLUICE	SCREW WORM DRIVE
2.1.7	36" x 24"	SLUICE	SCREW WORM DRIVE
2.1.8	36" x 24"	SLUICE	SCREW WORM DRIVE
2.1.9	36" x 24"	SLUICE	SCREW WORM DRIVE
2.1.10	36" x 24"	SLUICE	SCREW WORM DRIVE
2.1.11	36" x 24"	SLUICE	SCREW WORM DRIVE
2.1.12	36" x 24"	SLUICE	SCREW WORM DRIVE
2.1.13	36" x 24"	SLUICE	SCREW WORM DRIVE
2.1.14	36" x 24"	SLUICE	SCREW WORM DRIVE
2.1.15	36" x 24"	SLUICE	SCREW WORM DRIVE
2.1.16	36" x 24"	SLUICE	SCREW WORM DRIVE
2.1.17	36" x 24"	SLUICE	SCREW WORM DRIVE
2.1.18	36" x 24"	SLUICE	SCREW WORM DRIVE
2.1.19	36" x 24"	SLUICE	SCREW WORM DRIVE
2.1.20	36" x 24"	SLUICE	SCREW WORM DRIVE

NOTE: ALL SLUICE GATES - MANUAL OPERATED

VALVE SCHEDULE

VALVE NO.	TYPE	SIZE	FUNCTION
1.1	SLUICE	36"	DISCHARGE FROM EAST COLLECTOR
1.2	SLUICE	36"	DISCHARGE FROM EAST COLLECTOR
1.3	SLUICE	36"	DISCHARGE FROM EAST COLLECTOR
1.4	SLUICE	36"	DISCHARGE FROM EAST COLLECTOR
1.5	SLUICE	36"	DISCHARGE FROM EAST COLLECTOR
1.6	SLUICE	36"	DISCHARGE FROM EAST COLLECTOR
1.7	SLUICE	36"	DISCHARGE FROM EAST COLLECTOR
1.8	SLUICE	36"	DISCHARGE FROM EAST COLLECTOR
1.9	SLUICE	36"	DISCHARGE FROM EAST COLLECTOR
1.10	SLUICE	36"	DISCHARGE FROM EAST COLLECTOR
1.11	SLUICE	36"	DISCHARGE FROM EAST COLLECTOR
1.12	SLUICE	36"	DISCHARGE FROM EAST COLLECTOR
1.13	SLUICE	36"	DISCHARGE FROM EAST COLLECTOR
1.14	SLUICE	36"	DISCHARGE FROM EAST COLLECTOR
1.15	SLUICE	36"	DISCHARGE FROM EAST COLLECTOR
1.16	SLUICE	36"	DISCHARGE FROM EAST COLLECTOR
1.17	SLUICE	36"	DISCHARGE FROM EAST COLLECTOR
1.18	SLUICE	36"	DISCHARGE FROM EAST COLLECTOR
1.19	SLUICE	36"	DISCHARGE FROM EAST COLLECTOR
1.20	SLUICE	36"	DISCHARGE FROM EAST COLLECTOR

SCALE: TWO FEET TO ONE FOOT

CITY OF COLLIERVILLE
WASTEWATER TREATMENT FACILITIES
ENGINEERING

DESIGNED BY: [Signature]
 DRAWN BY: [Signature]
 CHECKED BY: [Signature]
 DATE: DEC. 79

PROJECT NO. [Number]
 SHEET NO. 5 OF 41

Attachment D. (Ditch #2 Configuration)

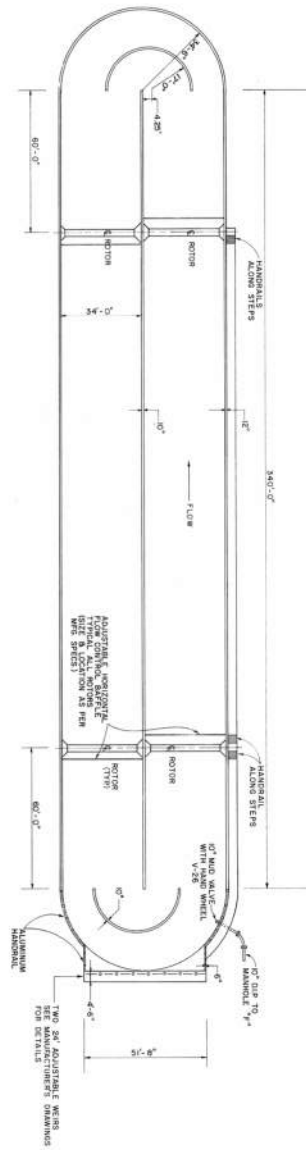

PLAN VIEW
SCALE: 1" = 80'-0"

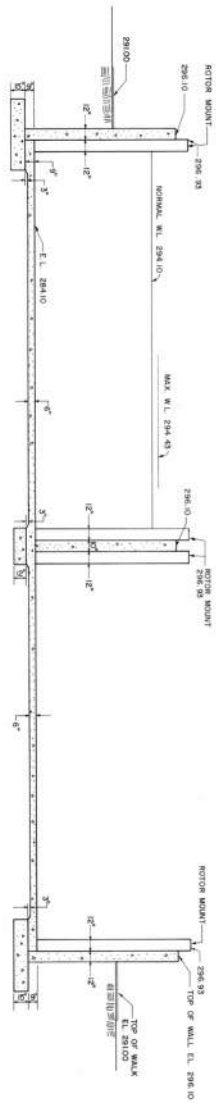

TYPICAL CROSS SECTION
SCALE: 1/4" = 1'-0"

APPROVED FOR CONSTRUCTION
BY THE DISTRICT ENGINEER
DIVISION OF WATER CONTROL
APR 23 1998

APPROVAL EXPIRES
APR 23 1998
THE DISTRICT ENGINEER

FISHER - PHILLIPS-ARNOLD			
CONSULTING ENGINEERS			
DIVISION OF WATER CONTROL			
WASTEWATER TREATMENT PLANT EXPANSION			
OXIDATION DITCH # 2			
039	DESIGN: J. L. C.	SCALE: AS NOTED	SHEET G-8
JOB NUMBER	DRAWN BY: K. A. B.	DATE: MARCH 1997	



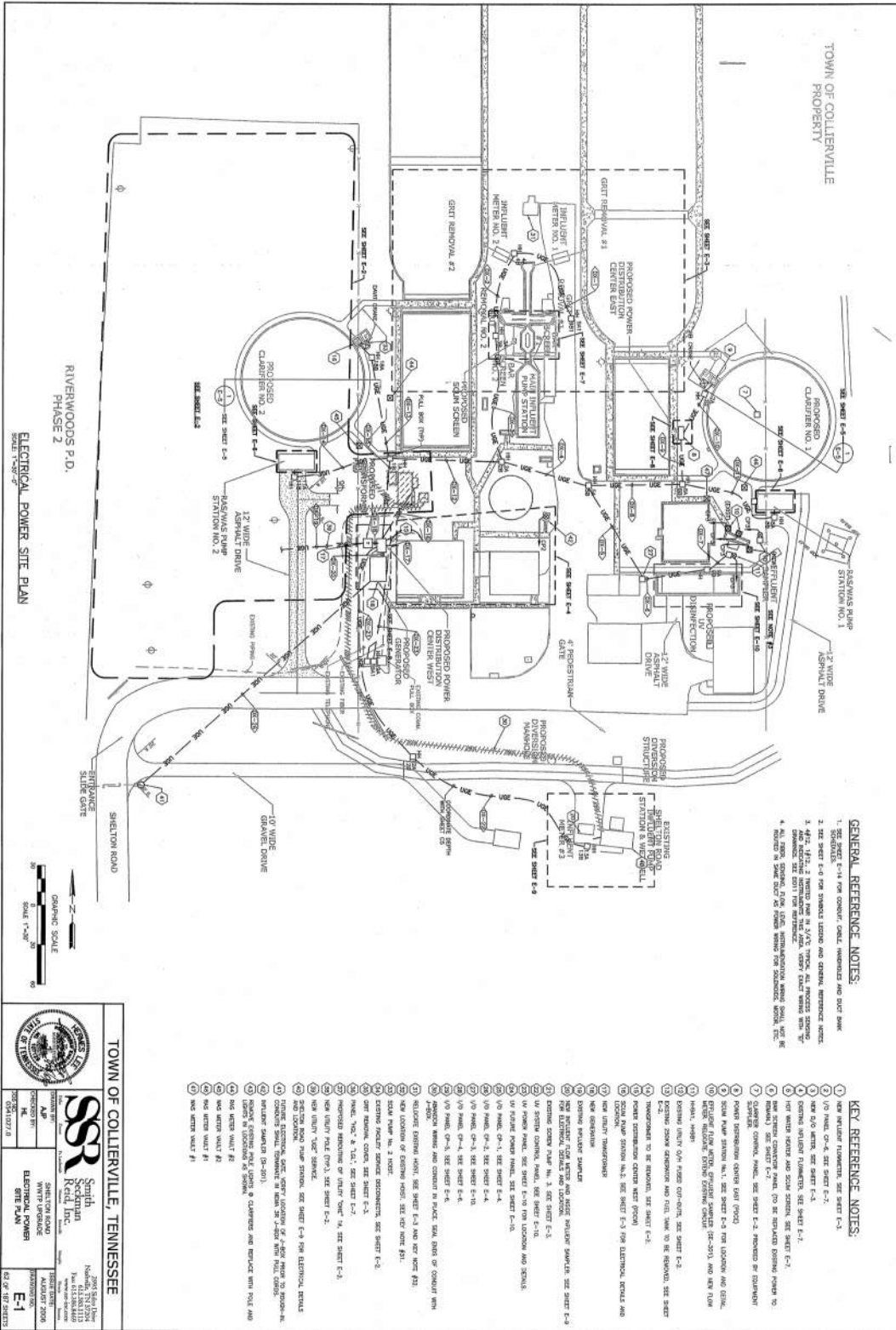

GENERAL REFERENCE NOTES:

1. SEE SHEETS E-14 FOR CONDUIT, CABLE, WIRING AND SHUT BANK
2. SEE SHEETS E-10 FOR SYMBOLS, LEGEND AND GENERAL REFERENCE NOTES
3. SEE SHEETS E-10 FOR SYMBOLS, LEGEND AND GENERAL REFERENCE NOTES
4. ALL 4" DIA. 2" THICK WALLS IN 4" X 8" TRUCKS, ALL PROPOSED STAIRS, AND ALL EXISTING STRUCTURES SHALL BE REINFORCED WITH #4 BARS @ 12" ON CENTER.
5. ALL 4" DIA. 2" THICK WALLS IN 4" X 8" TRUCKS, ALL PROPOSED STAIRS, AND ALL EXISTING STRUCTURES SHALL BE REINFORCED WITH #4 BARS @ 12" ON CENTER.
6. ALL 4" DIA. 2" THICK WALLS IN 4" X 8" TRUCKS, ALL PROPOSED STAIRS, AND ALL EXISTING STRUCTURES SHALL BE REINFORCED WITH #4 BARS @ 12" ON CENTER.
7. ALL 4" DIA. 2" THICK WALLS IN 4" X 8" TRUCKS, ALL PROPOSED STAIRS, AND ALL EXISTING STRUCTURES SHALL BE REINFORCED WITH #4 BARS @ 12" ON CENTER.
8. ALL 4" DIA. 2" THICK WALLS IN 4" X 8" TRUCKS, ALL PROPOSED STAIRS, AND ALL EXISTING STRUCTURES SHALL BE REINFORCED WITH #4 BARS @ 12" ON CENTER.
9. ALL 4" DIA. 2" THICK WALLS IN 4" X 8" TRUCKS, ALL PROPOSED STAIRS, AND ALL EXISTING STRUCTURES SHALL BE REINFORCED WITH #4 BARS @ 12" ON CENTER.
10. ALL 4" DIA. 2" THICK WALLS IN 4" X 8" TRUCKS, ALL PROPOSED STAIRS, AND ALL EXISTING STRUCTURES SHALL BE REINFORCED WITH #4 BARS @ 12" ON CENTER.

KEY REFERENCE NOTES:

1. NEW METAL FLEXIBLE SEE SHEET E-3
2. 1/2" FLEX SEE SHEET E-3
3. 1/2" FLEX SEE SHEET E-3
4. 1/2" FLEX SEE SHEET E-3
5. 1/2" FLEX SEE SHEET E-3
6. 1/2" FLEX SEE SHEET E-3
7. 1/2" FLEX SEE SHEET E-3
8. 1/2" FLEX SEE SHEET E-3
9. 1/2" FLEX SEE SHEET E-3
10. 1/2" FLEX SEE SHEET E-3
11. 1/2" FLEX SEE SHEET E-3
12. 1/2" FLEX SEE SHEET E-3
13. 1/2" FLEX SEE SHEET E-3
14. 1/2" FLEX SEE SHEET E-3
15. 1/2" FLEX SEE SHEET E-3
16. 1/2" FLEX SEE SHEET E-3
17. 1/2" FLEX SEE SHEET E-3
18. 1/2" FLEX SEE SHEET E-3
19. 1/2" FLEX SEE SHEET E-3
20. 1/2" FLEX SEE SHEET E-3
21. 1/2" FLEX SEE SHEET E-3
22. 1/2" FLEX SEE SHEET E-3
23. 1/2" FLEX SEE SHEET E-3
24. 1/2" FLEX SEE SHEET E-3
25. 1/2" FLEX SEE SHEET E-3
26. 1/2" FLEX SEE SHEET E-3
27. 1/2" FLEX SEE SHEET E-3
28. 1/2" FLEX SEE SHEET E-3
29. 1/2" FLEX SEE SHEET E-3
30. 1/2" FLEX SEE SHEET E-3
31. 1/2" FLEX SEE SHEET E-3
32. 1/2" FLEX SEE SHEET E-3
33. 1/2" FLEX SEE SHEET E-3
34. 1/2" FLEX SEE SHEET E-3
35. 1/2" FLEX SEE SHEET E-3
36. 1/2" FLEX SEE SHEET E-3
37. 1/2" FLEX SEE SHEET E-3
38. 1/2" FLEX SEE SHEET E-3
39. 1/2" FLEX SEE SHEET E-3
40. 1/2" FLEX SEE SHEET E-3
41. 1/2" FLEX SEE SHEET E-3
42. 1/2" FLEX SEE SHEET E-3
43. 1/2" FLEX SEE SHEET E-3
44. 1/2" FLEX SEE SHEET E-3
45. 1/2" FLEX SEE SHEET E-3
46. 1/2" FLEX SEE SHEET E-3
47. 1/2" FLEX SEE SHEET E-3
48. 1/2" FLEX SEE SHEET E-3
49. 1/2" FLEX SEE SHEET E-3
50. 1/2" FLEX SEE SHEET E-3
51. 1/2" FLEX SEE SHEET E-3
52. 1/2" FLEX SEE SHEET E-3
53. 1/2" FLEX SEE SHEET E-3
54. 1/2" FLEX SEE SHEET E-3
55. 1/2" FLEX SEE SHEET E-3
56. 1/2" FLEX SEE SHEET E-3
57. 1/2" FLEX SEE SHEET E-3
58. 1/2" FLEX SEE SHEET E-3
59. 1/2" FLEX SEE SHEET E-3
60. 1/2" FLEX SEE SHEET E-3
61. 1/2" FLEX SEE SHEET E-3
62. 1/2" FLEX SEE SHEET E-3
63. 1/2" FLEX SEE SHEET E-3
64. 1/2" FLEX SEE SHEET E-3
65. 1/2" FLEX SEE SHEET E-3
66. 1/2" FLEX SEE SHEET E-3
67. 1/2" FLEX SEE SHEET E-3
68. 1/2" FLEX SEE SHEET E-3
69. 1/2" FLEX SEE SHEET E-3
70. 1/2" FLEX SEE SHEET E-3
71. 1/2" FLEX SEE SHEET E-3
72. 1/2" FLEX SEE SHEET E-3
73. 1/2" FLEX SEE SHEET E-3
74. 1/2" FLEX SEE SHEET E-3
75. 1/2" FLEX SEE SHEET E-3
76. 1/2" FLEX SEE SHEET E-3
77. 1/2" FLEX SEE SHEET E-3
78. 1/2" FLEX SEE SHEET E-3
79. 1/2" FLEX SEE SHEET E-3
80. 1/2" FLEX SEE SHEET E-3
81. 1/2" FLEX SEE SHEET E-3
82. 1/2" FLEX SEE SHEET E-3
83. 1/2" FLEX SEE SHEET E-3
84. 1/2" FLEX SEE SHEET E-3
85. 1/2" FLEX SEE SHEET E-3
86. 1/2" FLEX SEE SHEET E-3
87. 1/2" FLEX SEE SHEET E-3
88. 1/2" FLEX SEE SHEET E-3
89. 1/2" FLEX SEE SHEET E-3
90. 1/2" FLEX SEE SHEET E-3
91. 1/2" FLEX SEE SHEET E-3
92. 1/2" FLEX SEE SHEET E-3
93. 1/2" FLEX SEE SHEET E-3
94. 1/2" FLEX SEE SHEET E-3
95. 1/2" FLEX SEE SHEET E-3
96. 1/2" FLEX SEE SHEET E-3
97. 1/2" FLEX SEE SHEET E-3
98. 1/2" FLEX SEE SHEET E-3
99. 1/2" FLEX SEE SHEET E-3
100. 1/2" FLEX SEE SHEET E-3

Attachment F. (Control locations)

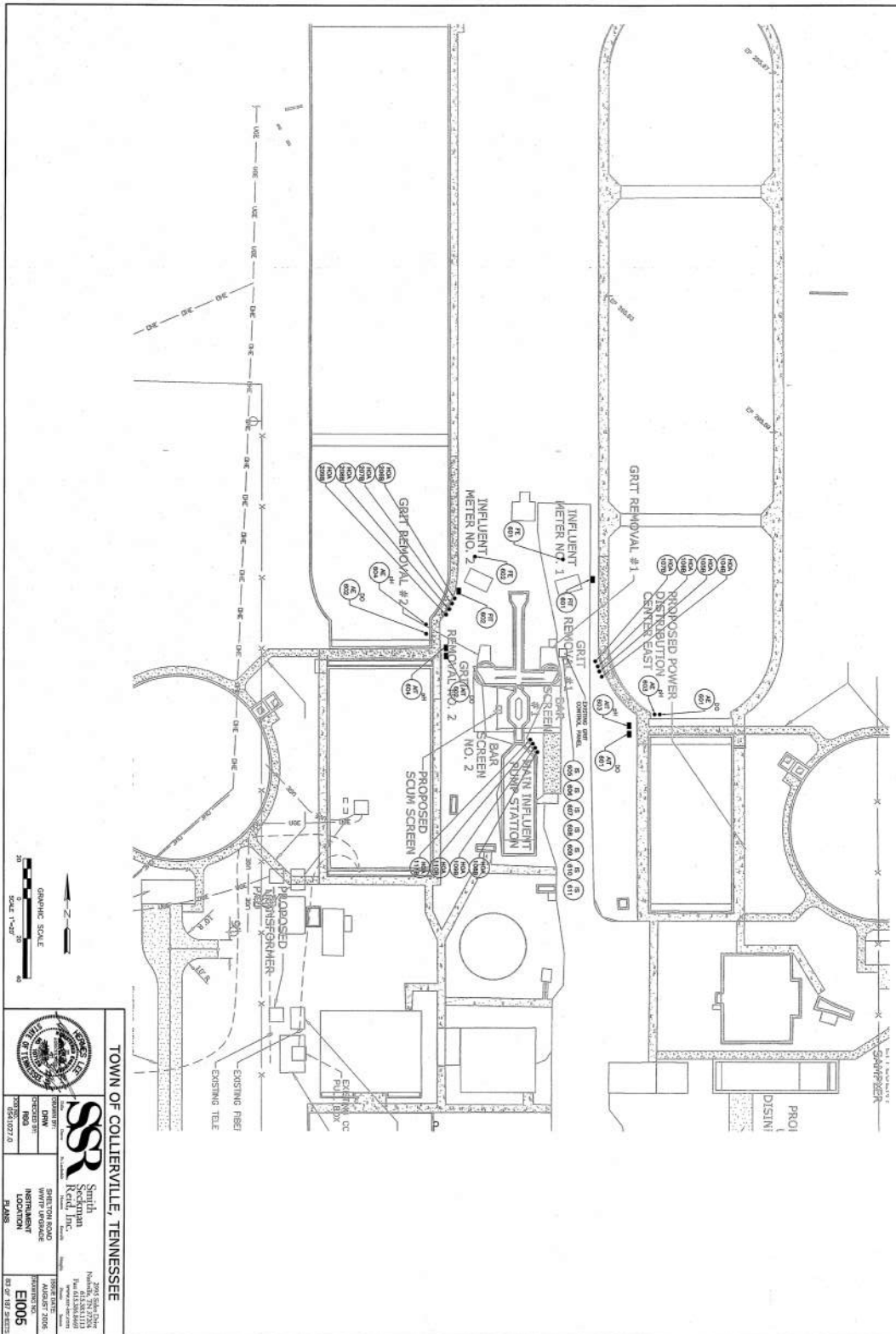

TOWN OF COLLETVILLE, TENNESSEE

SR
South
Riverside
Recreation
Authority

2001 South River
Nashville, TN 37203
Tel: 615.281.4444
Fax: 615.281.4444

DHW
DESIGNED BY
RMB
05/10/2006

PROJECT NO.
051077.0

PROJECT NO.
E005

DATE OF SHEET
05/10/2006

THIS DOCUMENT IS THE PROPERTY OF SRRA. IT IS TO BE USED ONLY FOR THE PROJECT AND LOCATION SPECIFICALLY IDENTIFIED HEREIN. IT IS NOT TO BE REPRODUCED OR TRANSMITTED IN ANY FORM OR BY ANY MEANS, ELECTRONIC OR MECHANICAL, INCLUDING PHOTOCOPYING, RECORDING, OR BY ANY INFORMATION STORAGE AND RETRIEVAL SYSTEM, WITHOUT THE WRITTEN PERMISSION OF SRRA.

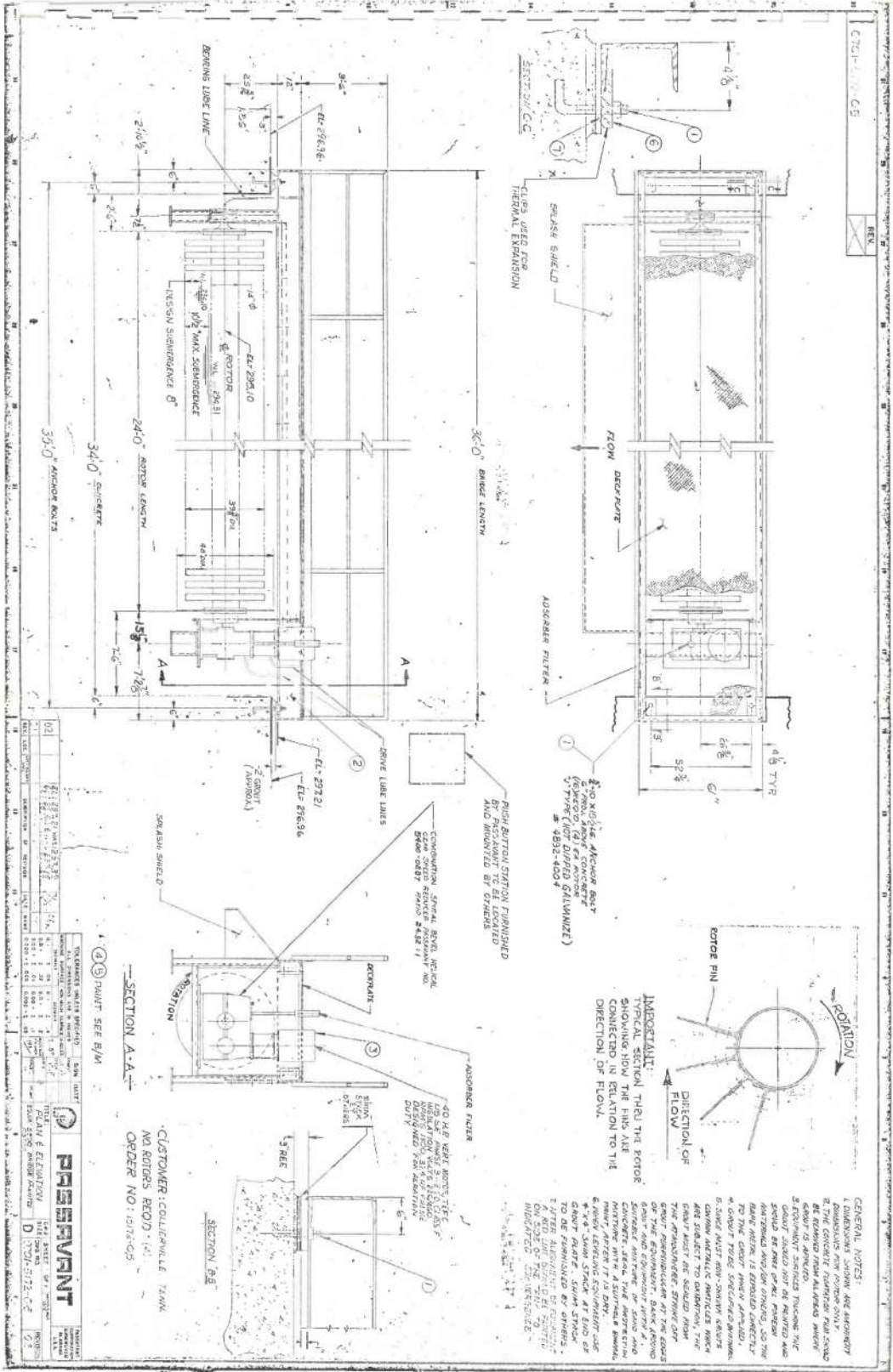

PRESPAVANT
 PLANNING & ENGINEERING
 1541 SHAW BLVD., SUITE 200
 WASHINGTON, DC 20020
 TEL: 202-552-1500
 FAX: 202-552-1501
 WWW.PRESPAVANT.COM
 PROJECT NO: 15172-CIS
 SHEET NO: 02
 DATE: 01/15/14

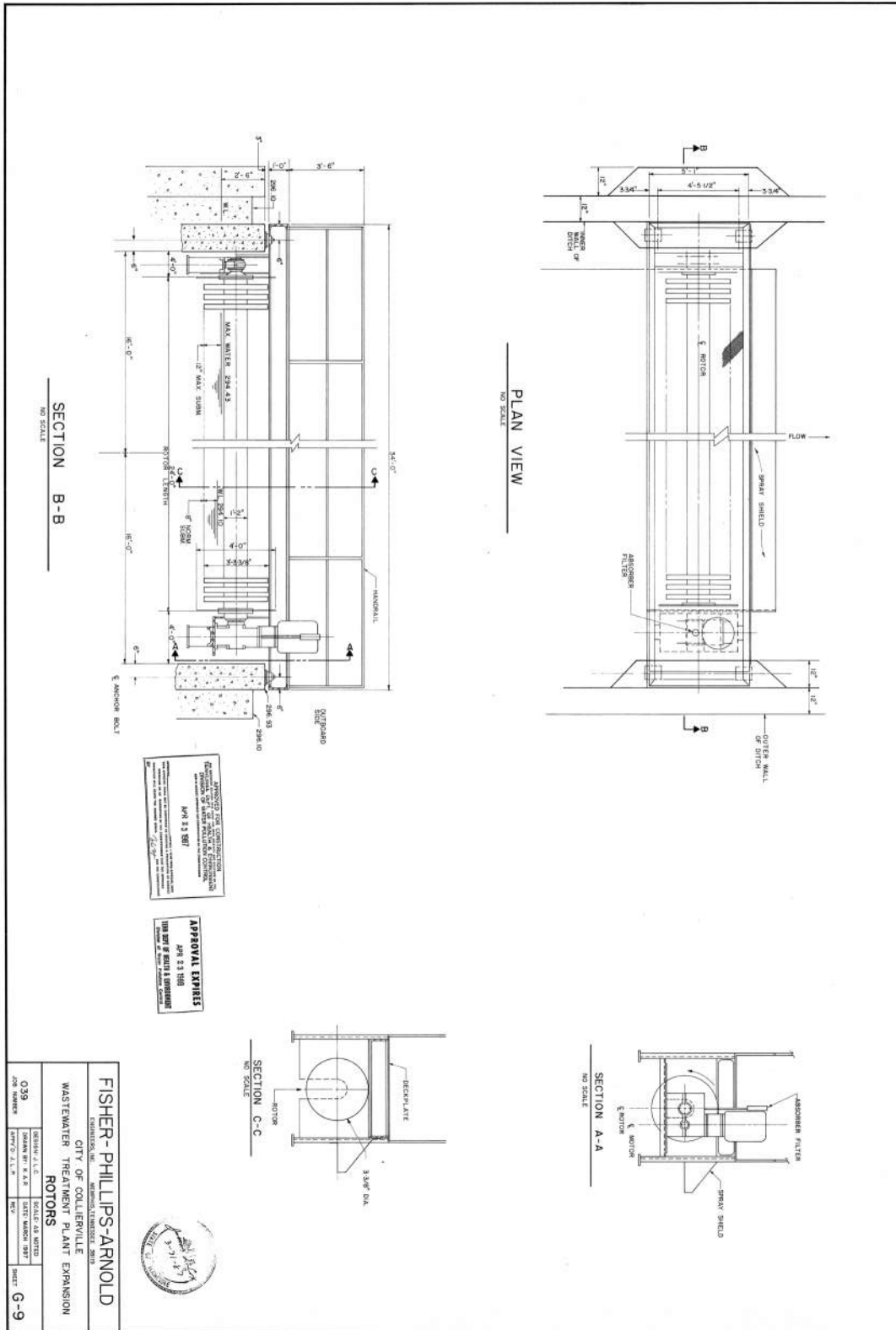

0787-2253-05

GENERAL NOTES:

- (1) SHIP TO COMPLETELY ASSEMBLE TO INSURE FIT.
- (2) SHIP TO PACK ITEM #10 WITH NEVER SEIZE COMPOUND PRIOR TO SHIPPING.
- (3) FIELD ERECTOR TO INSTALL THE BAFFLE AT 60 DEGREES OFF HORIZONTAL CENTERLINE AS SHOWN IN SECTION V-A-V' BELOW.
- (4) FIELD ERECTOR TO LEAVE HEX HEAD CAPSCREWS AS RECEIVED.
- (5) ITEMS IN ○ ARE FOR FIELD ERECTION.

SUGGESTED INSTALLATION PROCEDURE:

- REMOVE ALL PRIMER FROM GROUTING SIDE OF WALL MOUNTING PLATE PRIOR TO ANY INSTALLATIONS.
- (1) LOCATE 3/4" DIA. WEDGE ANCHORS AS SHOWN BELOW.
- USE SHIM STACKS TO HOLD THE 1" DIMENSION REQUIRED FOR GROUTING. SECURE WEDGE ANCHORS.
- (2) ASSEMBLE THE SUPPORT ANGLES (2-REQUIRED) TO THE WALL MOUNTING PLATES. TORQUE BOLTS TO 100 FT.-LBS.
- (3) FINAL STEP, HOIST THE BAFFLE ONTO THE SUPPORT ANGLES. USE NYLON SLINGS FOR HOISTING. SECURE WITH FASTENERS PROVIDED. TORQUE BOLTS TO 100 FT.-LBS.

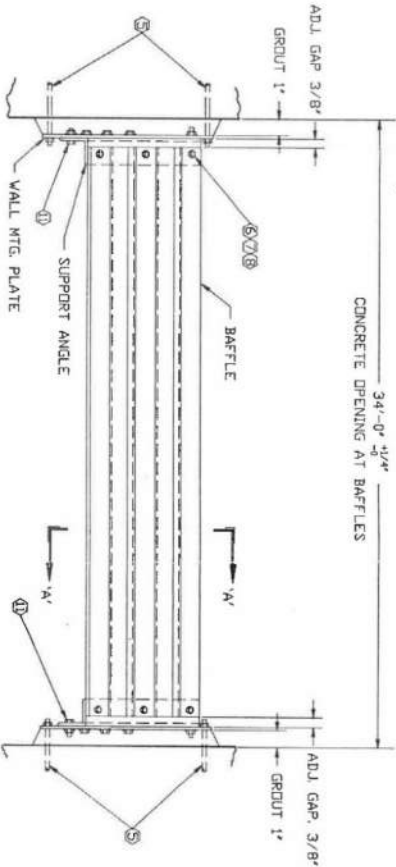

INSTALLATION VIEW

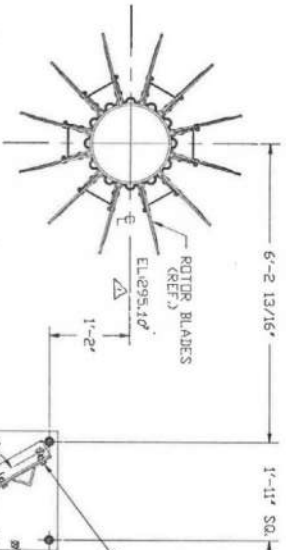

SECTION V-A-V'

3/4" DIA. WEDGE ANCHORS (GALV. STL.)

STANDARD FOR STRAIGHT-WALL DITCH - ONLY
 (60 POSITION ADAPTER IS 30, 45, & 60 DEGREE)

COLLIERVILLE W. W. T. P. COLLIERVILLE TENN.		DRAWN: J.L.V. CHECKED: J.C. 9/93	
TITLE: VELOCITY BAFFLE ASSEMBLY		SCALE: NONE	
DATE: 8-4-93		SHEET: 1 OF 2	
PROJECT NUMBER: 8782-3		DRAWING NUMBER: 0787-2253-05	
ZIMPRO PASSAVANT		01	

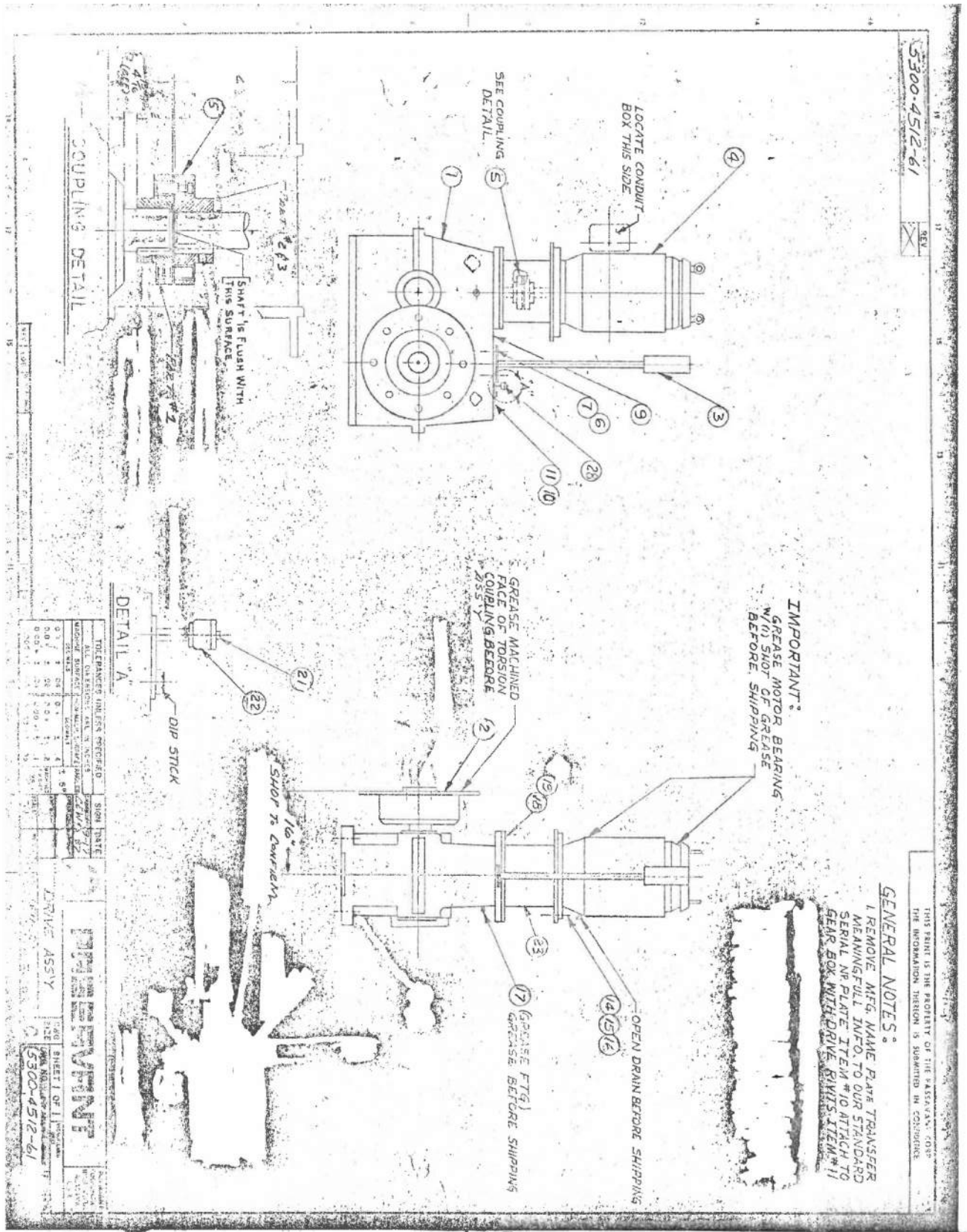

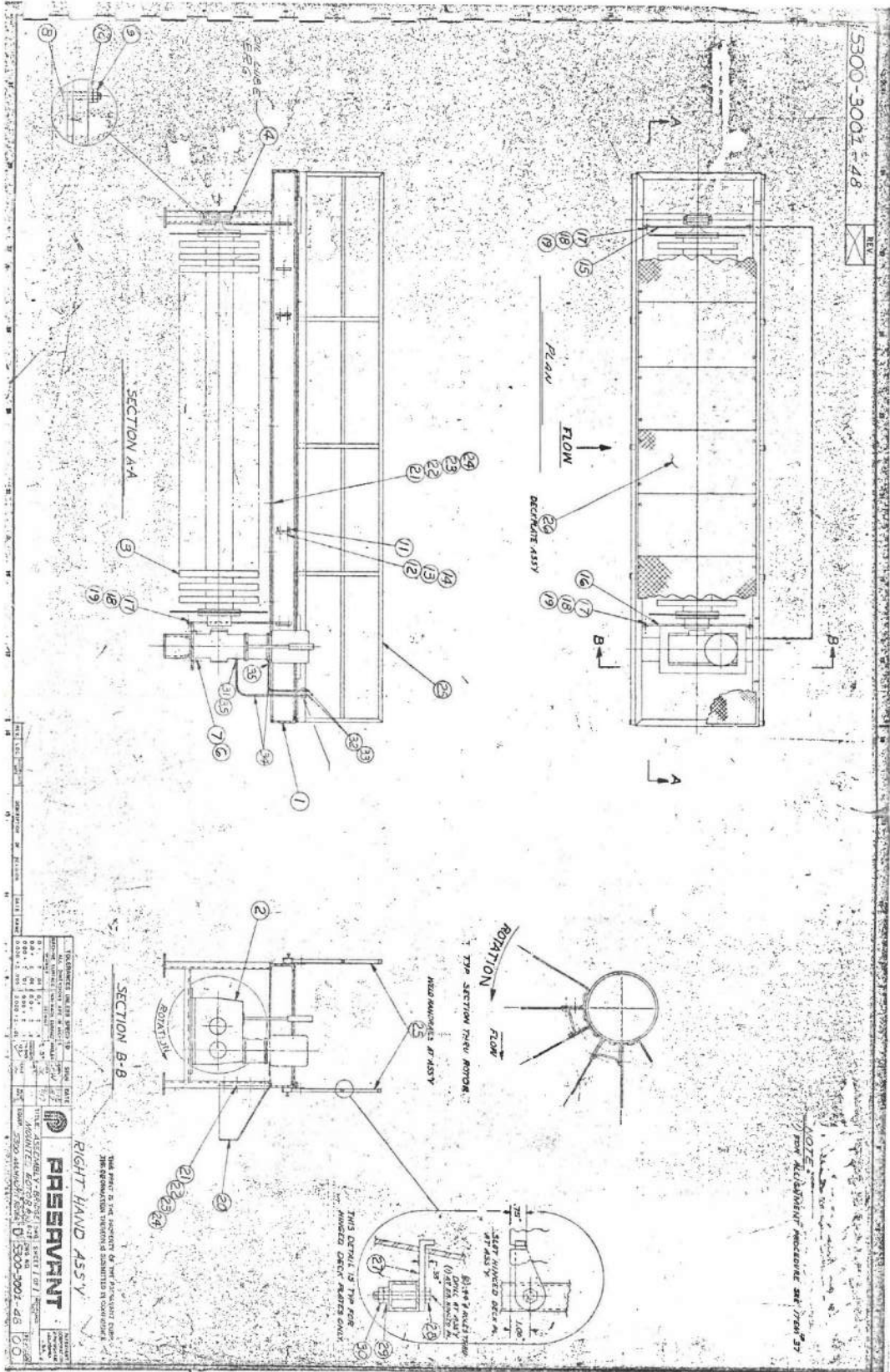

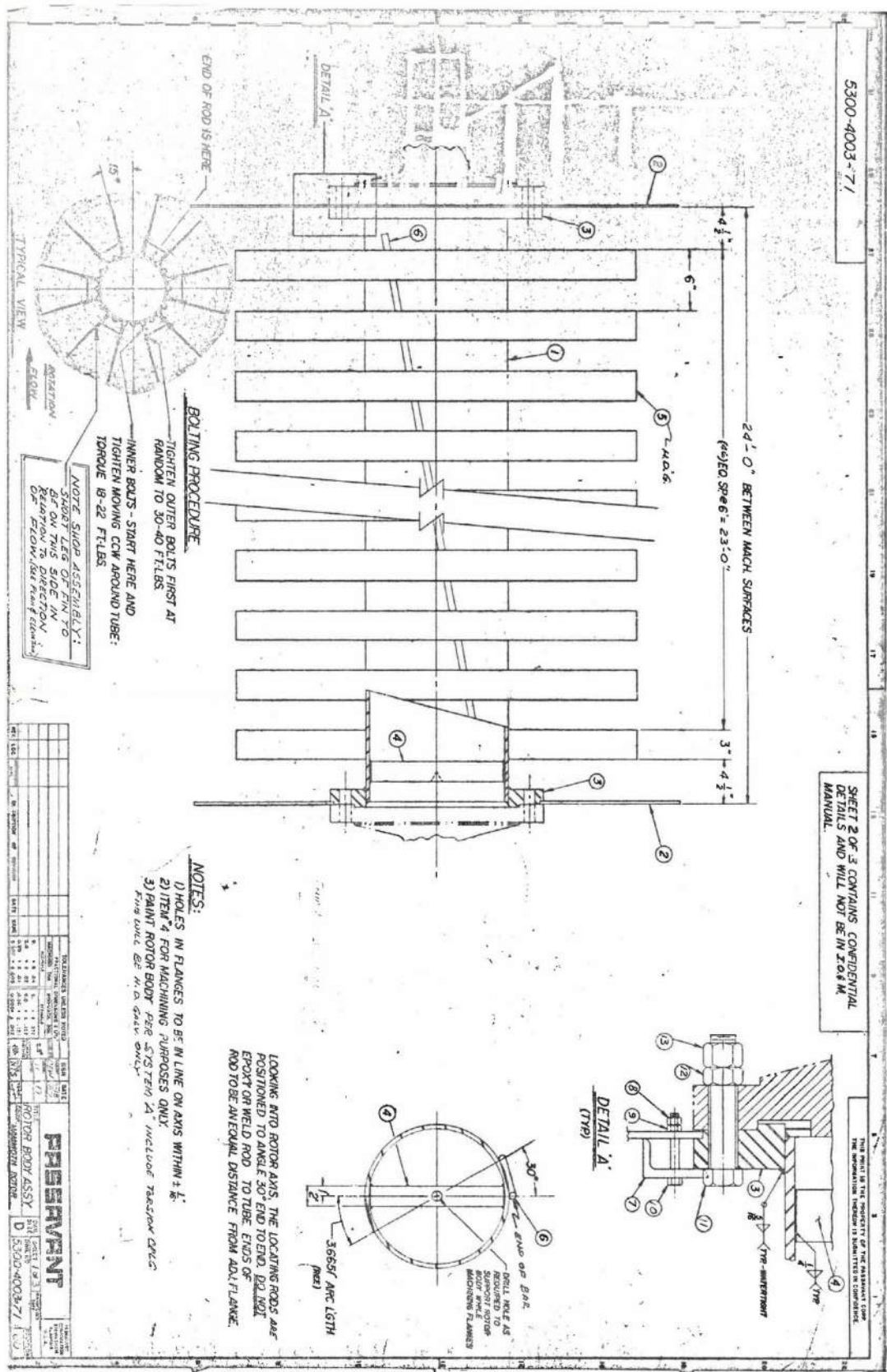

END OF ROD IS HERE

15°

ROTATION

FLOW

BOLTING PROCEDURE

TIGHTEN OUTER BOLTS FIRST AT RANDOM TO 30-40 FT.LBS.

INNER BOLTS - START HERE AND TIGHTEN MOVING CCW AROUND TUBE: TORQUE 18-22 FT.LBS.

NOTE SHIP ASSEMBLY:
 SHOOT LEG OF FIN TO GET ON THIS SIDE IN DIRECTION OF ROTATION OF ROTOR BODY ASSEMBLY

- NOTES:**
- 1) HOLES IN FLANGES TO BE IN LINE ON AXIS WITHIN ±.1"
 - 2) ITEM 4 FOR MACHINING PURPOSES ONLY
 - 3) PAINT ROTOR BODY PER SYSTEM 21 INCLUDE TRADESMAN DYES PER CODES SEE M.A. DATA SHEET

LOOKING INTO ROTOR AXIS, THE LOCATING RODS ARE POSITIONED TO ANGLE 30° END TO END. DO NOT POINT OR WELD ROD TO TUBE. ENDS OF ROD TO BE AN EQUAL DISTANCE FROM ADJ. FLANGE.

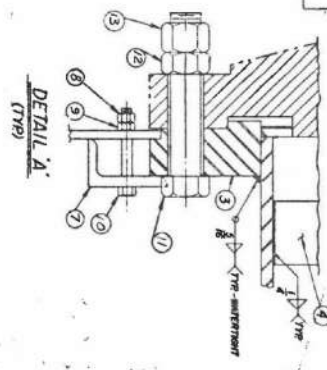
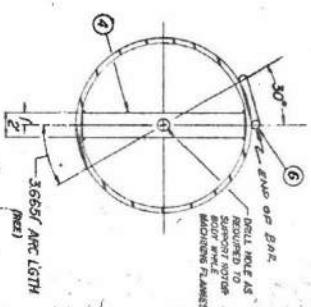

REV	DATE	BY	CHKD	DESCRIPTION
1	10/11/00

PERMANENT

5300-4003-71

STATE WATER INFRASTRUCTURE GRANTS
IDENTIFICATION SIGN

All plans and specifications for each project approved shall contain provisions for requiring the general contractor to provide identification signs. The signs shall conform to the following basic features:

1. The following diagram shall be used as a design:

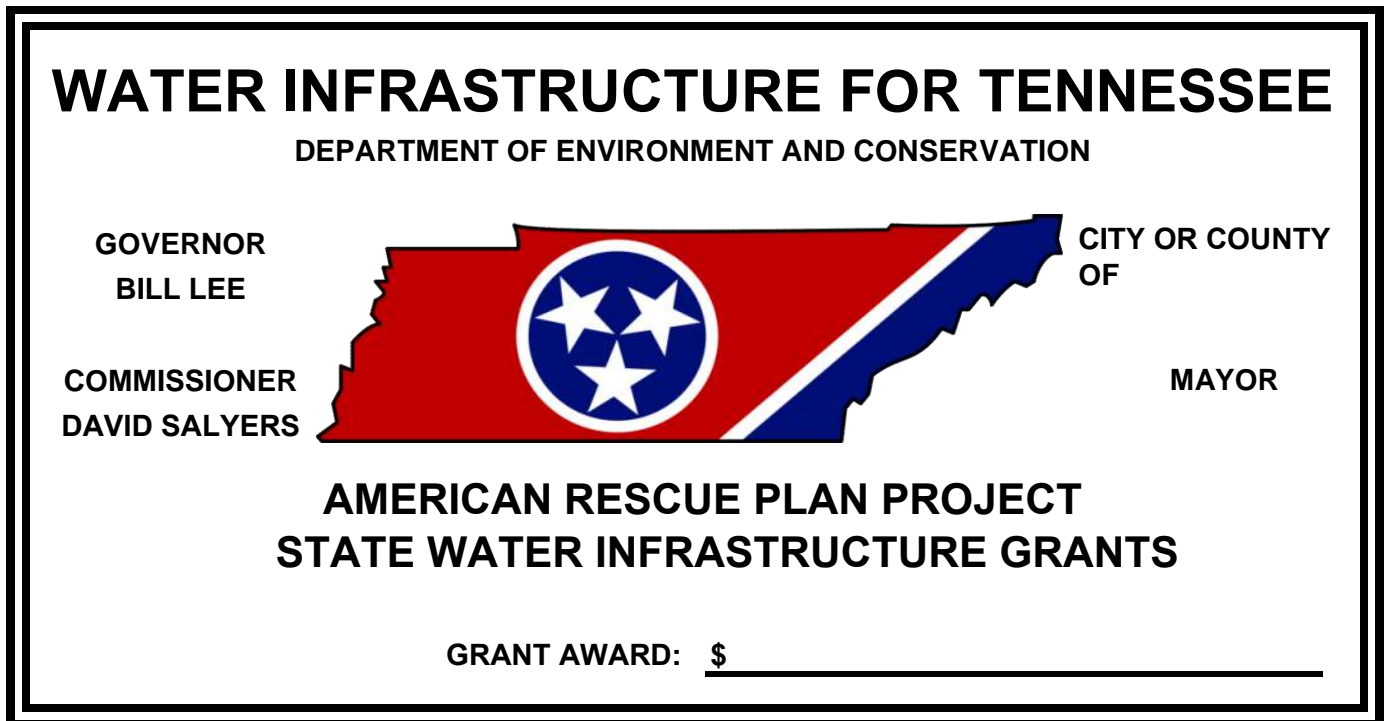

2. The sign shall be a 4'0" X 8'0" sheet of exterior grade plywood and shall be built so as to remain erected during the entire construction phase of the project.
3. The background of both sides shall be white. The lettering shall be black and shall be large enough to take advantage of the full size of the plywood. The stars shall be white set on a blue field and surrounded by a white ring placed inside a state map in red with a stripe of white and blue on the right side. The sign shall be bordered by a one-inch blue stripe.