



Public Project Information

For Construction and
Improvement Projects That
May Involve the Railroad

*Prepared by the Public Projects Group
CSX Transportation Inc.
Jacksonville, Florida
(last revised April 8, 2015)*



To the Communities, Businesses and Government Agencies

We Serve:

CSX Corporation and its business units CSX Transportation (CSXT) and CSX Intermodal (CSXI) provide rail and intermodal service in 23 states, the District of Columbia and two Canadian provinces. CSXT operates more than 1,200 trains daily, over 21,000 miles of track, helping America maintain the strongest and most productive transportation system in the world.

In addition to CSXT's vitally important customer service responsibilities, the company wants to be a good neighbor in the states and communities where we operate. That is why we have prepared this information. We want to make it easier for communities and other project sponsors to work with us when they have construction and improvement projects that may involve the CSXT rail property.

CSXT's Public Projects team is involved in a wide variety of projects initiated by government agencies, local businesses and others. Accurate and timely communication of information between CSXT and these parties improves planning, relationships and successful completion of projects. The tools in this manual explain important steps project sponsors must follow, including information required in connection with any public project proposal.

CSXT places the highest priority on safety – for its employees and for the public. Because CSXT is a business and its shareholders ultimately own its rail system, the company must also give careful consideration to anything that could adversely affect customer service, compensation for use of railroad property, and risk to railroad operation.

The Project Managers – Public Projects are the initial contact for CSXT and are assigned territories by state. Please contact them directly about public projects using the information provided. General Engineering Consultants (GEC) provide additional engineering services to assist CSXT in managing public projects.

CSXT hopes the information and procedures provided here will make it easier for us to work together.

Tony Bellamy
Director Project Management
Public Projects

CSXT Public Project Policy Information Table of Contents

Topic	Page	Revised
Information Covered in this Manual	3	9-09-14
CSXT Public Projects Staff and Territory Map	4	4-14-15
Additional CSXT Resources and Contacts	5	4-14-15
Definitions	6	9-09-14
Requirements for Preliminary Engineering Review	8	9-09-14
Payment of CSXT's Cost and Expense	9	9-09-14
Insurance Requirements for Public Projects	10	9-09-14
Entry onto CSXT Property	12	9-09-14
Construction Monitoring Requirements	13	9-09-14
Railroad Flagging for Activities On or Near CSXT Property and Tracks	14	9-09-14
Highway-Rail Grade Crossing Surface Maintenance and Replacement	16	9-09-14
Alterations to Highway-Rail Grade Crossing Warning Devices	17	9-09-14
Overhead and Undergrade Bridge Projects	18	9-09-14
Parallel Road Construction	19	9-09-14
Painting and Cleaning CSXT Bridges to Improve Appearance	20	9-09-14
Cleaning and Painting of Bridges over CSXT	21	9-09-14
Public Road Crossing Openings and Closures	22	9-09-14
Bicycle/Pedestrian Pathways and Multi-Use Trails	24	9-09-14
Quiet Zone Proposals	25	9-09-14
Appendix		
Standard Preliminary Engineering Agreement	27	05-09-11
Standard Construction Agreement	32	10-01-99
Temporary Right of Entry Agreement	43	09-09-14
ROE and Maintenance Agreement for Painting of CSXT Bridges (Aesthetic)	49	09-09-14
Special Provisions for Construction near CSXT Property	62	09-14-07
Overhead Bridge Criteria	66	10-01-99
Criteria for Ballast Deck Railroad Bridges	72	05-09-11
Construction Submission Criteria	78	04-14-15
Drainage Criteria	87	09-09-14

Additional information can be obtained by contacting the following:

- American Railway Engineering and Maintenance of Way Association,
(301) 459-3200, or www.arena.org

- U.S. Department of Transportation, Manual of Uniform Traffic Control Devices,
<http://mutcd.fhwa.dot.gov/>

Information Covered in This Manual

This information is intended to assist communities and other project sponsors to plan and implement construction and improvement projects that may involve the CSXT rail property. Examples of such projects include:

- **Highway-Rail Grade Crossings:** Closure, removal, installation and alterations of public highway-rail grade crossings. CSX's Property Services department manages private crossings.
- **Bridges Over CSXT:** Construction, reconstruction, rehabilitation, repair, removal, and maintenance of bridges over the railroad by outside parties.
- **Bridges Carrying CSXT:** Construction, reconstruction, rehabilitation, repair, removal, and maintenance of bridges carrying CSXT over highways and other public properties initiated by outside parties.
- **Parallel Roads/Facilities:** Construction, reconstruction, modification, removal, and maintenance of parallel roads or other public facilities affecting CSXT property or operations.
- **U.S. Army Corps of Engineers Projects:** Any project undertaken by the Corps of Engineers that involves CSXT property or operations.
- **Entry Onto CSXT Property:** Temporary rights of entry onto CSXT property, easements, utility installation and bridge inspections.
- **Other Projects Involving CSXT Rail Corridors:** Publicly sponsored projects involving or altering CSXT facilities or its property. These projects may be on, above, adjacent to, or otherwise have the potential to impact CSXT property.

Important notes:

The information herein is intended to be a tool only and all statements in this manual are intended to be for broad use. This manual cannot be taken as authority to construct. Specific projects will be subject to analysis of all factors leading to formal agreements between all parties. The purpose of review by CSXT is solely to ensure compliance with the minimum standards of CSXT, and not for any other purpose.

The guidelines and requirements herein are provided for reference only and are subject to revision without notice. All new projects shall be designed in accordance with the most current policies, requirements, and standards of CSXT.

Any items affecting railroad property not covered in this manual shall be subject to CSXT's prior review and approval.

The safety of CSXT employees and the general public is of paramount importance to CSXT.

CSXT Public Projects Staff and Territory Map

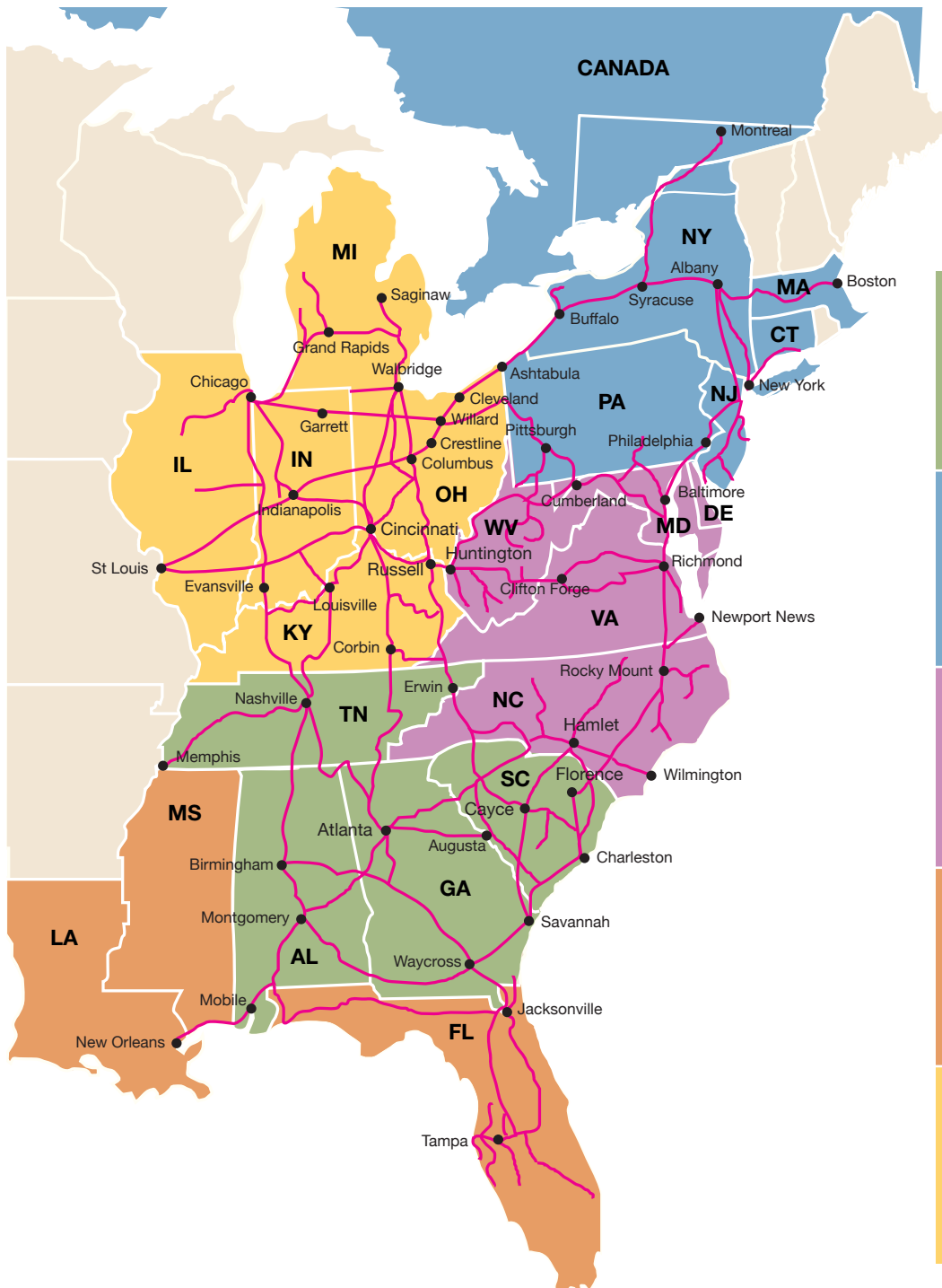

TN, AL, GA, SC

Douglas L. Spitznagel
351 Thornton Road, Suite 125
Lithia Springs, GA 30122
(770) 819-2842
Douglas_Spitznagel@csx.com

NY, PA, MA, NJ, CT, CANADA

Derek S. Mihaly
4 Neshaminy Interplex, Suite 205
Trevose, PA 19053
(215) 218-3391
Derek_Mihaly@csx.com

WV, VA, NC, MD, DE, DC

Troy J. Creasy
1610 Forest Ave, Suite 120
Richmond, VA 23229
(804) 226-7718
Troy_Creasy@csx.com

FL, MS, LA

Jacob Smith
500 Water Street, J-301
Jacksonville, FL, 32202
(904) 359-1650
Jacob_Smith@csx.com

MI, OH, IL, IN, KY

Amanda DeCesare
500 Meijer Drive, Suite 305
Florence, KY 41042
(859) 372-6124
Amanda_DeCesare@csx.com

Director Project Management – Public Projects

Tony C. Bellamy, P.E.
500 Water Street, J-301
Jacksonville, FL 32202
(904) 359-7601
fax (904) 366-4042
Tony_Bellamy@csx.com



Additional CSXT Resources and Contacts

Many areas of community interest are outside the scope of this manual. The following is a list of contacts within CSXT that may be helpful on other community matters:

- **Emergencies:** Emergencies and suspicious situations should be reported immediately to the CSX Public Safety Coordination Center, (800) 232-0144.
- **Corporate Communications and Public Affairs:** News media information, public affairs, state and community relations. Contact: (904) 366-2949.
- **Industrial Development:** New industry site locations, track proposals. Contact: Director Technical Programs, Regional Development (904) 359-1617.
- **Property Services:** Non-Construction and Environmental right-of-entry, wire line and pipeline crossings, private crossings, compliance with codes relating to right-of-way conditions. Contact: <http://csx.com/index.cfm/customers/non-freight-services/propertyreal-estate/permitting-utility-installations-and-rights-of-entry/>
- **Quiet Zones:** Contact: TellCSX@csx.com or (877) 835-5279.
- **Railroad Track and Signal Maintenance:** Track maintenance, drainage maintenance, maintenance of highway-rail grade crossings surfaces and warning systems. Contact: TellCSX@csx.com or (877) 835-5279.
- **Real Estate Lease or Purchase:** Contact: <http://csx.com/index.cfm/customers/non-freight-services/propertyreal-estate/>
- **Structures and Bridges:** Maintenance of bridges that are CSXT's responsibility. Contact: Assistant Chief Engineer - Structures (904) 359-1104.
- **Passenger Operations:** Amtrak, passenger train proposals, commuter train proposals, light rail corridors. Contact: Director Passenger Services Strategy (904) 359-1099.
- **Rails to Trails:** Conversion of unused rail lines to trails. Contact: Manager Public Agency Services (904) 279-4491.
- **Non Emergency Issues:** Contact: TellCSX@csx.com or (877) 835-5279.

I. Definitions

1. *Agency* – The project sponsor (i.e., State DOT, Local Agencies, Private Developer, etc.)
2. *AREMA* – American Railway Engineering and Maintenance-of-Way Association – the North American railroad industry standards group. The use of this term shall be in specific reference to the AREMA Manual for Railway Engineering.
3. *Construction Submission* – The Agency or its representative shall submit six (6) sets of plans, supporting calculations, and detailed means and methods procedures for the specific proposed activity. All plans, specifications, and supporting calculations shall be signed/sealed by a Professional Engineer as defined below.
4. *Controlled Demolition* – Removal of an existing structure or subcomponents in a manner that positively prevents any debris or material from falling, impacting, or otherwise affecting CSXT employees, equipment or property. Provisions shall be made to ensure that there is no impairment of railroad operations or CSXT's ability to access its property at all times.
5. *Contractor* – The Agency's representative retained to perform the project work.
6. *Engineer* – CSXT Engineering Representative or a GEC authorized to act on the behalf of CSXT.
7. *Flagman* – A qualified CSXT employee with the sole responsibility to direct or restrict movement of trains, at or through a specific location, to provide protection for workers.
8. *GEC* – General Engineering Consultant who has been authorized to act on the behalf of CSXT. GECs perform preliminary engineering, construction inspection, and monitoring under the direction of the CSXT Engineering personnel. GEC personnel also perform day-to-day administration of certain types of projects.
9. *Horizontal Clearance* – Distance measured perpendicularly from centerline of any track to the nearest obstruction at any elevation between TOR and the maximum vertical clearance of the track.
10. *Professional Engineer* – An engineer who is licensed in State or Commonwealth in which the project is to occur. All plans, specifications, and supporting calculations shall be prepared by the Professional Engineer and shall bear his seal and signature.
11. *Potential to Encroach* – Work having the possibility of impacting CSXT property or operations; defined as one or more of the following:
 - a. Any activity where access onto CSXT property is required.
 - b. Any activity where work is being performed on CSXT ROW.
 - c. Any excavation work adjacent to CSXT tracks or facilities, within the Theoretical Railroad Live Load Influence Zone, or where the active earth pressure zone extends within the CSXT property limits.
 - d. The use of any equipment where, if tipped and laid flat in any direction (360 degrees) about its center pin, can encroach within twenty five feet (25'-0") of the nearest track centerline. This is based upon the proposed location of the equipment during use, and may be a function of the equipment boom length. Note that hoisting equipment with the potential to foul must satisfy the 150% factor of safety requirement for lifting capacities.
 - e. Any work where the scatter of debris or other materials has the potential to encroach within twenty five feet (25'-0") of the nearest track centerline.
 - f. Any work where significant vibration forces may be induced upon the track structure or existing structures located under, over, or adjacent to the track structure.
 - g. Any other work which poses the potential to disrupt rail operations, threaten the safety of railroad employees, or otherwise negatively impact railroad property, as determined by CSXT.

12. *ROW* – Right of Way; Refers to CSXT Right-of-Way as well as all CSXT property and facilities. This includes all aerial space within the property limits, and any underground facilities.
13. *Submission Review Period* – A minimum of 30 days will be required for the initial review response. Up to an additional 30 days may be required to review any/all subsequent submissions or resubmission.
14. *Theoretical Railroad Live Load Influence Zone* – A 1½ horizontal to 1 vertical theoretical slope line starting 1'-6" below TOR elevation and 12'-0" from the centerline of the nearest track.
15. *TOR* – Top of Rail. This is the base point for clearance measurements. It refers to the crown (top) of the steel rail; the point where train wheels bear on the steel rails. Use the higher of the two rails when track is superelevated.
16. *Track Structure* – All load bearing elements which support the train. This includes, but is not limited to, the rail, ties, appurtenances, ballast, sub-ballast, embankment, retaining walls, and bridge structures.
17. *Vertical Clearance* – Distance measured from TOR to the lowest obstruction, within six feet (6'-0") of the track centerline, in either direction.



Requirements for Preliminary Engineering Review

Key Points

- **Starting CSXT Preliminary Engineering (PE) early by providing conceptual plans lowers project costs and shortens the time required for CSXT review and approval**
- **Using standard agreements lowers costs and saves time**
- **If the proposal requires an easement on CSXT property, the project sponsor should contact CSXT Real Property when beginning PE.**
- **If the proposal requires a utility encroachment, the project sponsor should contact CSXT Property Services when beginning PE.**
- **PE typically costs \$8,000 to \$25,000**
- **CSXT PE Review will not begin until the PE Agreement is fully executed and PE funds are received.**

Overview

Any project proposals that may affect or be near the CSXT right-of-way must be evaluated by CSXT. To initiate a construction or improvement project, a PE agreement is required to identify the project sponsor, the scope, define the tasks to be accomplished, and specify the payment required. Once the plans for the project are approved by CSXT, a construction agreement will be developed.

Purpose

The purpose of the PE is to identify issues related to safety, engineering, customer service, operations, legal and regulatory matters, expense, risk and other considerations specific to any proposed project. CSXT review of plans is only to determine that the plans, and improvements constructed in accordance with the plans, satisfy CSXT's requirements. Plans should be submitted early in project development to ensure that CSXT requirements can be incorporated.

Process Steps To Be Taken

- Notify CSXT Public Projects Group of the project by providing location information and conceptual plans.
- Provide CSXT authorization to incur preliminary engineering costs.
- Review and complete a standard PE agreement and provide payment for expenses as specified in the agreement.
- Provide project information; attend meetings (as needed), review site with CSXT or GEC personnel.
- Submit initial plans to CSXT or designated GEC for review.
- Respond to CSXT or designated GEC comments and adjust design if necessary.
- Submit final design for CSXT or designated GEC review.
- CSXT will perform final review to ensure compliance with railroad requirements.
- CSXT will estimate the cost of the work to be done by CSXT, including flagging.
- If CSXT takes no exceptions to the design plans (or once all CSXT concerns have been addressed), CSXT will prepare a standard construction agreement for execution.

Costs and Expenses

These matters are covered in more detail in the section that follows ("Payment of CSXT's Costs and Expenses"). For the reasons described in that section, CSXT requires advance payment for its costs and expenses of reviewing and handling the PE. All expenses of the party seeking the review will be borne by that party, including expenses for CSXT employees or GEC personnel attending meetings, reviewing plans, preparing correspondence and other activities to support the review of the project.

Timing

It is in the interest of all parties to complete the PE review before commitments are made or construction steps begin. CSXT will work to be responsive, with timing depending upon the complexity of the project. CSXT and its GEC will work with the project sponsor to schedule PE and construction to meet project schedule objectives whenever possible, considering available resources.

Standard Documents

CSXT executes hundreds of agreements each year for preliminary engineering and construction of projects. CSXT has developed standard agreements which can be executed by CSXT without additional legal review. Non-standard agreements or modifications to the CSXT standard agreement terms will require additional legal review and may increase project duration and/or cost. Sample standard agreement documents are available in the Appendix.



Payment of CSXT's Costs and Expenses

Key Points and Procedures

- Preliminary Engineering (PE) costs are paid in advance.
- CSXT construction expenses will be estimated during PE and the estimate will be incorporated into the construction agreement. Advance payment is required to cover these expenses prior to the start of project construction.
- If CSXT anticipates that actual expenses will exceed the advance payment, additional payment will be required. Project work may be stopped until additional payment is received.
- If CSXT's actual expenses are less than the sum of any deposits the difference will be refunded after final cost accounting.
- All funding sources must be identified up front, and any time funding sources change, CSXT must be immediately informed.

Overview

The types of projects being addressed in this manual usually do not directly benefit and, in some cases, create risk to, and hurdles for, CSXT's core business of providing transportation service vital to its customers and the American economy. For these reasons, CSXT seeks payment for its costs and expenses incurred in connection with project review or construction.

Examples of Costs and Expenses

Agency shall reimburse CSXT for all costs and expenses incurred by CSXT in connection with the Project, including, without limitation:

- All out of pocket expenses
- Travel and lodging expenses
- Telephone, facsimile, and mailing expenses
- Costs for equipment, tools, materials and supplies
- Sums paid to CSXT's consultants and subcontractors
- CSXT labor in connection with the Project (included but not limited to flagging), together with CSXT labor overhead percentages established by CSXT pursuant to applicable law
- For estimating purposes only, typical flagging costs are \$1,300 per day.



Insurance Requirements for Public Projects

I. Insurance Policies:

Agency and Contractor, if and to the extent that either is performing work on or about CSXT's property, shall procure and maintain the following insurance policies:

1. Commercial General Liability (CGL) coverage at their sole cost and expense with limits of not less than \$5,000,000 in combined single limits for bodily injury and/or property damage per occurrence, and such policies shall name CSXT as an additional insured.
2. Statutory Worker's Compensation and Employers Liability Insurance with limits of not less than \$1,000,000, which insurance must contain a waiver of subrogation against CSXT and its affiliates [if permitted by state law].
3. Commercial Automobile Liability insurance with limits of not less than \$1,000,000 combined single limit for bodily injury and/or property damage per occurrence, and such policies shall name CSXT as an additional insured.
4. Railroad Protective Liability (RPL) insurance with limits of not less than \$5,000,000 combined single limit for bodily injury and/or property damage per occurrence and an aggregate annual limit of \$10,000,000, which insurance shall satisfy the following additional requirements:
 - a. The Railroad Protective Liability Insurance Policy must be on the ISO/RIMA Form of Railroad Protective Insurance - Insurance Services Office (ISO) Form CG 00 35.
 - b. CSX Transportation must be the named insured on the Railroad Protective Liability Insurance Policy. The named insured's address should be listed as:

CSX Transportation, Inc.
500 Water Street, C-907
Jacksonville, FL 32202
 - c. The name and address of the Contractor and of the Project Sponsor/Involved Governmental Agency must be shown on the Declarations page.
 - d. A description of operations and location must appear on the Declarations page and must match the Project description.
 - e. Terrorism Risk Insurance Act (TRIA) coverage must be included.
 - f. Authorized endorsements must include:
 - (i). Pollution Exclusion Amendment - CG 28 31, unless using form CG 00 35 version 96 and later
 - g. Authorized endorsements may include:
 - (i). Broad Form Nuclear Exclusion - IL 00 21
 - (ii). Notice of Non-renewal or cancellation
 - (iii). Required State Cancellation Endorsement
 - (iv). Quick Reference or Index - CL/IL 240

- h. Authorized endorsements may not include:
 - (i). A Pollution Exclusion Endorsement except CG 28 31
 - (ii). An Endorsement that excludes TRIA coverage
 - (iii). An Endorsement that limits or excludes Professional Liability coverage
 - (iv). A Non-Cumulation of Liability or Pyramiding of Limits Endorsement
 - (v). A Known Injury Endorsement
 - (vi). A Sole Agent Endorsement
 - (vii). A Punitive or Exemplary Damages Exclusion
 - (viii). A "Common Policy Conditions" Endorsement
 - (ix). Policies that contain any type of deductible
 - (x). Any endorsement that is not named in Section 4 (f) or (g) above that CSXT deems unacceptable
- 5. All insurance companies must be A. M. Best rated A- and Class VII or better
- 6. Such additional or different insurance as CSXT may require

II. Additional Terms

- 1. Contractor must submit the complete Railroad Protective Liability policy, Certificates of Insurance and all notices and correspondence regarding the insurance policies in an electronic format to:

insurancedocuments@csx.com

Neither Agency nor Contractor may begin work on or about CSXT property until written approval of the required insurance has been received from CSXT or CSXT's Insurance Compliance vendor, Ebix.



Entry onto CSXT Property

Key Points

Written permission is required for all parties entering CSXT property.

- **Construction Agreements authorize entry onto CSXT property.**
- **Temporary right-of-entry agreements can also be used for limited purposes.**
- **CSXT Property Services handles temporary rights of entry for non-construction activities.**
- **CSXT Public Projects handles temporary rights of entry for construction activities.**
- **All parties must adhere to CSXT Safety procedures.**
- **Appropriate insurance is required.**

Overview

To maintain efficient customer service and to ensure the safety of CSX employees and of those parties requesting access to CSXT property, CSXT requires all parties accessing its right-of-way for investigative activities or for the performance of construction work to have a written agreement with CSXT fully detailing each party's responsibilities. Activities by others with the potential to affect CSXT's property, operations, and or personnel without actually entering CSXT property must also be reviewed with CSXT and appropriate arrangements and agreements completed.

The process by which an appropriate agreement covering entry and/or the other necessary conditions or requirements can be developed and implemented is typically dependent upon the scope of the activities proposed by an outside party or agency. Although the type of agreement may vary, most agreements include insurance and liability provisions, work procedures and conditions and reimbursement provisions relating to payment to CSXT for costs it may incur in relation to the entry or work. The following summarizes the various types of CSXT agreements and contracts most frequently utilized to accommodate the requested entry and the proposed work activities.

Entry for Construction Work via CSXT Public Projects

Entry for construction work (not exclusively associated with utility work) will require a Construction Agreement or a Temporary Right-of-Entry Agreement, as determined by the magnitude of potential impacts to CSXT.

A Construction Agreement will be required for construction work that could impact CSXT facilities or operation, such as construction or rehabilitation of a bridge over CSXT, roadway construction or other highway improvements, or grading and/or drainage work.

Construction work that will not impact CSXT facilities or operation may be handled by a Temporary Right-of-Entry Agreement, as determined by CSXT Public Projects.

Entry for Non-Construction Work via CSXT Property Services

A Temporary Right-of-Entry agreement is utilized by CSXT primarily in situations where outside parties or agencies desire to undertake investigative work such as performing survey work, taking borings, performing bridge inspections or undertaking other activities requiring only access to CSXT property and not construction work activities. Different agreements are used for temporary private crossings.

Applications for Temporary Right-of-Entry agreements for investigative and non-construction work activities (including movement of off-highway or oversized loads at grade crossings) within CSXT's right-of-way can be obtained by contacting CSXT Property Services department online at www.csx.com. Click on "Community – Property and Projects," and then click on "Learn more" under "Utility installations and Rights of Entry."

Entry For Other Purposes via CSXT Property Services

CSXT may use other forms of agreements covering entry by outside parties or agencies depending on work scope or other factors. The process to obtain right of entry for these purposes as listed below may also be initiated through CSXT's Property Services department. Information also is available by visiting www.csx.com

- Environmental Right-of-Entry
- Utility Permit/License Agreement for pipeline and wire line construction – both for specifications and applications
- Land Lease applications
- Movement of oversized loads across CSXT tracks at private or public highway-rail grade crossings
- Movement of off highway construction equipment across CSXT tracks at private or public highway-rail grade crossings



Construction Monitoring Requirements

Key Points

- **Construction work affecting CSXT will be monitored by CSXT and its consultants at the project sponsor's expense.**
- **Construction monitoring is in addition to flagging and other protective services.**

Overview

To ensure the safety of the public and CSXT employees, maintain quality rail service to CSXT customers and to protect CSXT assets, CSXT may require construction monitoring (in addition to flagging protection) of the project. The construction monitoring will be conducted by CSXT and its consultants at project expense.

General Guidelines

Construction monitoring includes intermittent or continuous on-site presence of CSXT or its consultants during construction activities.

- The construction project sponsor, owner, or agency in charge will pay for the cost of construction monitoring. Construction monitoring will be specified, and the estimated cost will be included in the construction agreement for the project.
- Construction monitoring is in addition to railroad employee flagging.
- Construction monitoring includes CSXT review and approval of all plan changes and required contractor submissions during the construction phase of the project.
- The project sponsor is responsible for its safety and the safety of its property, contractors, and employees. CSXT, as part of its construction monitoring, will review the work site for activities that could interfere with safe operation of the railroad.
- CSXT and its consultants are not responsible for monitoring the general work activities under the direction of the project sponsor for compliance with safety regulation. Any observed unsafe acts or conditions will be reported immediately to the project sponsor or contractor representative.



Railroad Flagging for Activities On or Near CSXT Property and Tracks

Key Points

- **Flagging services are required when projects are within close proximity to active rail lines, as required by federal law.**
- **Flagging services can only be performed by qualified CSXT personnel.**
- **Arrangements for flagging services may take up to 90 days to schedule a qualified employee.**

Overview

In the interest of public safety and the safety of employees and property, CSXT will work cooperatively with agencies, consultants, contractors and others who need to access railroad property when work brings them in close proximity to active railroad tracks to determine the appropriate flagging services needed and to make arrangements for those services.

Conditions When CSXT Flagging Services Are Required:

- When any entity is working on, near or adjacent to active railroad tracks.
- When an outside party is using railroad property or performing operations that may affect railroad property or facilities. This includes occasions when a party has been given express permission from CSXT to enter railroad property or perform such operations under the terms of a Construction agreement, Temporary Right-of-Entry agreement or other appropriate documentation.
- When work off railroad property has the potential to impact CSXT property or operations.
- When off-highway construction equipment is crossing the railroad at a private or public crossing.
- When oversized equipment or highway vehicles are to cross the railroad at a private or public crossing.
- In other instances as determined by CSXT.

Qualified Flagging Personnel

CSXT flagging services may only be performed by qualified CSXT employees who are trained in the proper procedures related to rail operations and safety requirements, familiar with rail operations and procedures in a project area and able to communicate directly with CSXT dispatching personnel and train crews.

Arrangements for CSXT Flagging Services

- CSXT will make arrangements for flagging services related to planned work by an outside party under the terms of a temporary right-of-entry agreement, construction agreement, environmental license agreement or other mutually acceptable arrangements.
- Advance notice must be provided to secure CSXT flagging services. The level of advance notice may vary from site to site or project to project or if CSXT determines, under the provisions of its labor agreements with its union forces, that flagging services can only be provided as a result of the flagging position being bid and awarded to qualified CSXT personnel.

Responsibility for Costs and Expenses

- All costs and expenses associated with CSXT flagging services are the sole responsibility of the agency, consultant or contractor.
- CSXT will provide its estimated costs prior to the start of the project work or its assignment of flagging personnel.
- Once flagging personnel are formally assigned by CSXT to a specific work location, the period of assignment can only be changed with appropriate advanced arrangements.
- Charges for providing flagging services beyond a normal eight-hour weekday are calculated and billed at an overtime rate.
- For initial planning purposes, typical flagging cost is \$1,300 per day.

Examples of Flagging Costs and Expenses

Charges billed by CSXT to the agency, consultant or contractor may include, but are not limited to:

- Employee Salary
 - Hourly employee charges are based on the time an employee departs and returns to his or her headquarters location. As such, the charges can be expected to exceed the level actually incurred during the assigned coverage period or while the flagman is present at the specific work location.
 - This period also includes the time required for flagging personnel to perform the required preparations and termination procedures associated with flagging services at a location.
- Overhead Costs
 - These charges are assessed against the hourly employee charges and determined in accordance with standard accounting procedures or as mandated by State and/or Federal regulations.
- Employee Expenses or Per Diem Rate
 - This amount is calculated based on an employee's actual expenses or on a per diem rate according to the terms of applicable collective bargaining agreements between CSXT and its assigned union flagging employees.
 - The amount includes travel and lodging expenses and the cost for a leased, rented, CSXT, or personal vehicle to be used for transportation.
- Administrative, Accounting, and Billing Services
 - This amount is related to the time associated with setting up the agreement, arranging for and supervising the employee, billing and collection of costs, and other expenses associated with CSXT providing flagging services.



Highway-Rail Grade Crossing Surface Maintenance and Replacement

Key Points

- Report issues with crossing surfaces to TellCSX. (TellCSX@csx.com or 1-877-TELLCSX)
- Coordination is required for work near crossings.
- Highways must be closed to vehicular traffic for crossing replacement or maintenance work.
- Agreements with CSXT are required for crossing work and work near crossings.
- Crossing surface maintenance and replacement must be performed by CSXT.
- Crossing surfaces must meet criteria set by CSXT's Engineering Standards. For identification purposes, each crossing has a distinct DOT inventory number (such as 123456A) posted at the crossing and the railroad milepost.

Overview

The crossing surface provides a path for highway vehicles to cross railroad tracks. The objective is to provide a safe, smooth, and cost effective crossing for highway and railroad traffic. Highway and railroad maintenance work in the vicinity of highway-rail grade crossings must consider safety concerns for both highway and railroad traffic before, during, and after the time the work is implemented.

Identification of the crossing and location

Each crossing has a unique DOT inventory identification number posted at the crossing. There is often more than one crossing on the same road. The crossing number (such as 123456A) must be used to identify the specific crossing in all communications with the railroad to reduce possible confusion about the specific location.

Crossing Construction

Railroad track is continuous through the crossing and includes railroad ties, rail and fasteners below the surface of the crossing. The crossing surface for highway traffic can be made of several different materials. Drainage is required for all four quadrants at a crossing.

Crossing Surface Types and Selection

Crossing surface material and construction methods are selected for each crossing based on the type of highway and railroad traffic, past experience and funding available from highway agencies for individual projects.

Standard types of CSXT approved crossing surfaces are Concrete or Timber/Asphalt. Projects funded by outside parties may be constructed with other materials if specified by the outside party and approved by CSXT. Modular Platform "Tub" type crossings may be considered for use at locations with slow rail operations of 15 MPH or less and high road vehicle count and/or heavy vehicles.

Crossing Maintenance and Replacement

Crossing maintenance and replacement of the track and crossing surface are performed by CSXT and may be billable to an outside party or highway authority as specified in an agreement. The responsibility for the maintenance of public crossing approach pavement varies by state and is specified in some individual crossing agreements or orders.

Crossing work requires closing the entire highway-rail grade crossing. Replacement of track components through a crossing requires removal of the crossing surface, replacement of track ballast, and surfacing the track through the crossing prior to replacement of the crossing surface. If the subgrade needs to be improved, the application of a hot mixed asphalt underlayment should be considered. Drainage will be reestablished for all four quadrants. After the crossing surface is replaced, the highway approach paving is completed and then the road is opened to highway traffic. Replacement of the track and crossing surface usually requires that the highway be closed for several days.

Crossing surfaces are also removed and replaced when track maintenance work is performed through a crossing such as rail replacement, tie replacement, and track surfacing (smoothing). Each crossing has the surface removed and replaced after the work has been completed. Crossings are usually closed for several days during this maintenance work.

Requesting Crossing Surface Replacement or Upgrades

Highway agencies seeking replacement of crossing surfaces should contact CSXT Public Projects. The request for the work and the recommended surface must be reviewed and approved by CSXT. If approved, Public Projects will prepare a standard agreement and include the cost estimate for the project.



Alterations to Highway-Rail Grade Crossing Warning Devices

Key Points

- Any alterations to highway-rail grade crossing warning systems must adhere to all applicable laws, regulations and national standards.
- Requests to CSXT for new or modified public at-grade crossing warning devices must be initiated by the highway agency.
- Preliminary Engineering agreements are used to define the project scope and prepare design and estimate information for each project.
- The requesting project sponsor will be responsible for advance payment for engineering, design and installation of warning devices.
- The coordination of traffic intersection signals with warning devices will be determined by the highway agency or regulatory agency.
- Construction agreements are used to implement the projects.

Overview

The Public Projects Group will process all projects proposing alterations to public highway-rail grade crossing warning systems. Included will be projects for opening new crossings, closing existing crossings, modifying or widening of existing crossings, installing new warning systems, removing and/or relocating existing warning systems and modifying/upgrading existing warning systems.

Identification of the crossing and location

Each crossing has a unique DOT inventory identification number posted at the crossing. There is often more than one crossing on the same road. The number (such as 123456A) must be used to identify the specific crossing in all communications with the railroad to reduce possible confusion about the specific location.

Design Considerations

Highway-rail grade crossing warning systems must adhere to all applicable Federal and State standards and regulations, and local policies, laws and ordinances, as well as CSXT standards. The highway agency, not CSXT, is responsible for determining the level and configuration of warning devices for a public highway-rail grade crossing. In addition, the highway agency or other governmental agency responsible for making warning system and equipment determinations is responsible for selecting appropriate vehicular traffic control signs and/or devices for a specific public highway. Loop Detection Circuitry will not be designed, installed, owned, or maintained by CSXT.

Recommended practices and additional information are available in American Railway Engineering and Maintenance of Way Association (AREMA) manuals and the Manual on Uniform Traffic Control Devices (MUTCD).

Engineering, Cost Estimation, Installation

CSXT will provide engineering, design, and cost estimates for the installation of highway-rail grade crossing warning devices at the expense of the project sponsor as part of the Preliminary Engineering for a project. Changes to highway-rail grade crossing surfaces may also require engineering and estimating by CSXT. Because of labor agreements with CSXT's union forces, CSXT will install the highway-rail grade crossing warning devices.

Operation of Highway-Rail Grade Crossing Warning Devices

Highway-rail grade crossing warning systems are designed to activate in advance of a train entering the crossing. Train speed changes while approaching the crossing may cause the warning system to activate longer than expected. Trains stopping or making forward and reverse movements near the crossing may cause the warning system to activate and then clear after an appropriate time without a train entering the crossing.

Traffic Light Preemption Interconnection

The highway agency will determine if preemption is required. Preemption of the cycle of traffic signals at highway intersections near highway-rail grade crossings requires careful review by highway traffic engineers to determine the appropriate timing and sequence for both the traffic signal and the highway-rail grade crossing warning system. Preemption for the traffic signal may be simultaneous with, or in advance of, the warning system activation. The appropriate sequence and timing shall be provided by the highway agency and distributed to CSXT to facilitate CSXT's signal design. CSXT will furnish one preemption interconnection circuit of a normally closed contact that is designed to open upon the approach or presence of a train and will terminate the closed preemption interconnection circuit in a common cable junction box to be used for the interconnection of the traffic signals and the grade crossing warning devices.



Overhead and Undergrade Bridge Projects

Key Points

- Overhead and undergrade bridge projects must comply with CSXT's policies and standards, which are available in the appendices of this manual.
- All work on overhead and undergrade bridges must be reviewed and approved by CSXT.
- CSXT should be involved early in the project development phases to allow required bridge standards to be incorporated into the design of the project.
- A preliminary engineering agreement and construction agreement will be required.
- CSXT property and operations (including train speeds) shall not be negatively impacted by the project.
- No temporary reduced clearances will be permitted.
- CSXT requires that new overhead bridges (including existing bridge replacements) span CSXT's right-of-way and have a minimum 23' vertical clearance above top of rail.
- All new undergrade bridges must have a ballast deck.
- MSE walls are prohibited on CSXT property.

Overview

Given the efficiencies and environmental benefits of moving goods by rail, CSXT continues to see strong demand for rail services across its network. It is critical that CSXT maintain the ability to expand its network in the future.

CSXT requires that new overhead bridges (including existing bridge replacements) span CSXT's right-of-way and have a minimum 23' vertical clearance above top of rail. CSXT requires that new undergrade bridges provide accommodations for future operating needs, as determined by CSXT.

During project construction, rail operations must not be impeded. Temporary run-around track(s) and/or phased construction may be necessary as determined by CSXT.

General Guidelines

- All bridge projects over or under CSXT shall be governed by the appropriate criteria found in the appendices. This includes but is not limited to replacements, new construction, substructure modifications and/or repairs, superstructure replacement or repair, and deck replacement or overlay.
- Temporary and final drainage plans must be approved by CSXT.
- CSXT's access to its property must be maintained.
- Plans must show all tracks and horizontal and vertical track clearances for both the existing conditions and the proposed project.
- Bridge demolition criteria are found in the Overhead Bridge Criteria in the appendices of this manual.
- Upon completion of construction, a full set of as-built drawings, showing actual measured vertical and horizontal clearances, shall be furnished to CSXT.



Parallel Road Construction

Key Points

- **Proposed parallel public roads shall be located off CSXT property.**
- **Safety at existing highway-rail grade crossings must be considered and not adversely impacted.**
- **No additional drainage may be directed onto railroad property.**
- **CSXT's access to its property must not be impeded.**
- **Construction may result in the need for alterations to crossing warning systems or facilities.**

Overview

In the interest of public safety, parallel public roads shall be located off CSXT property. Parallel roads involving intersections with existing or proposed highways where public or private crossings are present should be aligned to provide sufficient distance from the crossing for the largest vehicle (design vehicle) permitted to use the road to stop between the railroad and the parallel road traffic control signs, markings, and warning devices without interfering with railroad operations, obstructing or preventing the operation of traffic control devices or obstructing the crossing in any manner.

General Guidelines

The design of highways, highway intersection, and configuration of highway-rail grade crossings is the responsibility of the highway agency. Drainage for highway runoff, the railroad corridor, and adjacent property must be designed to reduce or maintain existing railroad drainage and to prevent standing water and potential erosion. Access for CSXT equipment to the railroad property, structures, and track cannot be restricted or prevented.

Federal and State design manuals, the Manual of Uniform Traffic Control Devices (MUTCD) and additional recommended practices available in American Railway Engineering and Maintenance of Way Association manuals (AREMA) provide design information to be considered by the highway agency responsible for the project engineering. The table of contents of this document has additional information on the MUTCD and AREMA manuals and information.



Painting and Cleaning CSXT Bridges to Improve Appearance

Key Points

- **CSXT understands the desire of communities to improve the appearance of bridges and other structures. Safety of CSXT employees, the general public and neighbors restrict some alternatives for bridge appearance improvement.**
- **CSXT may permit others to paint CSXT bridges if labor agreement, technical and responsibility requirements are resolved.**
- **Any surface preparation methods must follow all applicable environmental guidelines and must be approved in advance by CSXT.**
- **CSXT will not accept proposals to attach signage to CSXT bridges.**
- **A written request should be submitted to CSXT's Public Projects Group to initiate consideration of such projects.**

Overview

Requests are occasionally made by outside parties for various beautification projects, including painting of overhead and undergrade bridges. These requests are considered on a case-by-case basis by CSXT. The cost of painting and future aesthetic maintenance will be the responsibility of the project sponsor proposing to paint the CSXT bridge. CSXT will make every effort to cooperate, consistent with maintaining the safety of the public and the safe operation of the railroad.

Consideration of Bridge Painting Projects

Bridge painting proposals must be reviewed and approved by CSXT to ensure compliance with safety and environmental regulations, CSXT specifications, and to ensure that the proposal will not impact CSXT's property or operations.

- CSXT will require an agreement for all bridge painting proposals.
- A public agency must be a party to the agreement.
- CSXT will incur no costs or liabilities as a result of the project.
- The public agency or its designee will be responsible for maintenance of the painted surfaces, including aesthetic damage caused by highway vehicles and vandalism.
- A railroad flagman will be required at the project expense.

Submission of Project Requests

A written request by the party wishing to undertake such projects should be forwarded to CSXT's Public Projects Group for handling. The request should include information about the situation and the project objectives to assist CSXT with completion of the review. The following information should be included:

- The project sponsor and public agency that will execute appropriate agreements for implementation as well as future maintenance of the painted surfaces.
- Paint specifications that meet CSXT standards and methods for surface preparation, cleanup, and paint application.
- Qualifications and experience of the painting contractor. CSXT will accept state qualified bridge painting contractors working for the responsible agency or company. Containment system, clean up and disposal of all paint and other material removed from the bridge. The clean-up and disposal of material from the surface preparation for painting and actual painting must comply with all appropriate regulations.
- The materials removed during the surface preparation must not impact the surrounding area including ground, water, or air impacts. Materials must not be stored on CSXT property.
- Control of paint overspray and vapors during application. The work must be done complying with appropriate regulations and over spray controlled to prevent damage to adjacent property and vehicles in the area.
- Pictures and conceptual drawing should be submitted with the initial request from the community to simplify the initial review and comment by CSXT.
- Work site safety plan including keeping all personnel away from the tracks and fall protection measures where required.



Cleaning and Painting of Bridges over CSXT

Key Points

- **CSXT understands that maintenance of bridges over CSXT may include cleaning and painting. The safety of CSXT employees, the general public, and the project sponsor's contractors is of paramount importance to CSXT.**
- **A written request should be submitted to CSXT's Public Projects Group to initiate this type of project. The request will be reviewed for safety considerations and compliance with CSXT engineering and environmental standards.**
- **An agreement is required to accommodate engineering, review of plans, flagging, right-of-entry, and payment of CSXT incurred costs.**

Overview

All work over CSXT has the potential to impact CSXT property and rail operations. CSXT will review bridge painting and cleaning projects to ensure environmental and engineering standards are met. This review, flagging protection and construction monitoring costs will be paid by the project sponsor.

Requirements for Initiating and Implementing Bridge Cleaning and Painting

A Preliminary Engineering agreement is required to cover CSXT's review of the project and preparation of a cost estimate and construction agreement.

To ensure safety, a railroad employee flagman must be present to control railroad operations in the area during the planned work.

A written request by the party wishing to undertake such projects should be forwarded to CSXT's Public Projects Group for handling. The request should include information about the location and the project objectives to assist CSXT with completion of the review. The following information should be included:

- The project sponsor and appropriate public agency that will execute appropriate agreements for implementation as well as future maintenance of the painted surfaces.
- Qualifications and experience of the painting contractor. CSXT will accept state qualified bridge painting contractors working for the responsible agency or company.
- Containment system, clean up and disposal of all paint and other material removed from the bridge. The clean-up and disposal of material from the surface preparation for painting and actual painting must comply with all appropriate regulations.
- The materials removed during the surface preparation must not impact the surrounding area including ground, water, or air impacts. Materials must not be stored on CSXT property.
- Control of paint overspray and vapors during application. The work must be done complying with appropriate regulations and over spray controlled to prevent damage to adjacent property and vehicles in the area.
- Pictures and conceptual drawing should be submitted with the initial request from the community to simplify the initial review and comment by CSXT.
- Work site safety plan including keeping all personnel away from the tracks and fall protection measures where required.



Public Road Crossing Openings and Closures

Key Points

- **Both federal and state government policies discourage the creation of new highway-rail grade crossings. To enhance highway-rail grade crossing safety, CSXT endorses the United States Department of Transportation's goal of reducing the number of at-grade crossings through consolidation, elimination, grade separation and restriction of the number of new crossings installed.**
- **Grade separated structures are the best alternative to add new roads or additional highway capacity.**
- **CSXT and state and federal agencies have worked with many communities to develop and implement projects that improve highway traffic flow without the creation of new highway-rail grade crossings.**
- **CSXT, the Federal Railroad Administration (FRA), and state agencies encourage communities to consider all alternatives before planning to create new grade crossings and encourage closure of existing grade crossings where possible.**
- **CSXT may provide incentive payments for crossing closures.**
- **To comply with and in support of the federal initiative to reduce crossings, CSXT requires the community to identify three comparable active grade crossings to be closed for each new grade crossing.**

Overview

CSXT understands the importance of highway-rail grade crossings and their relevance to such priorities as economic development, emergency vehicle access and other growth opportunities in the communities through which we operate. Because of the safety concerns associated with highway-rail grade crossings, however, every effort must be made to obtain alternative access or additional capacity using grade separations, or by other roads leading to existing crossings.

Crossing Closure Incentive Program

Eliminating crossings is a goal of CSXT, states and the Federal Railroad Administration (FRA). Likewise, the Federal Highway Administration (FHWA) Railroad-Highway Grade Crossing Handbook acknowledges that the first alternative that should always be considered for a highway-rail at-grade crossing is elimination. Elimination of a crossing provides the highest level of crossing safety because the point of intersection between highway and railroad is removed. Closing adjacent crossings simplifies the design, installation and operation of highway-rail grade crossing warning systems. To help ensure the success of this effort, CSXT may provide incentive payments for the closure of public crossings.

Considerations for Crossing Openings and Closures

The addition of any grade crossing brings the potential for incidents involving trains and motor vehicles. For this reason, both federal and state government policies discourage the creation of new grade crossings. CSXT, other railroads, the United States Department of Transportation and most states encourage communities to carefully consider all alternatives, including grade separations (crossings that go over or under railroad tracks), as opposed to the creation of new at-grade crossings. The cost of a grade separation should not outweigh the enhanced safety it would provide for motorists.

CSXT, the FRA and other railroads actively participate in programs such as Operation Lifesaver, an initiative dedicated to educating the public on the importance of practicing safe driving procedures at grade crossings. For more information about crossing safety, visit: <http://www.beyondourrails.org/safety>

Before agreeing to the establishment of a new crossing, CSXT expects communities to engage in a study with the purpose of identifying existing redundant public crossings for closure. To comply with and in support of the federal initiative to reduce grade crossings, CSXT requires that the community identify the closure of three or more comparable active public at-grade crossings.

Policies and Procedures to Guide New Crossing Requests:

The project sponsor requesting a new crossing or seeking to convert a private crossing to a public crossing will be asked to prepare a written request, presenting the following information:

1. A description of the proposed highway project, including proposed passive or active traffic control devices, and the need for preemption and/or interconnection with traffic signals, together with a scale drawing or sketch of the proposed highway and vicinity.
2. Expected Annual Average Daily Traffic (AADT) and proposed vehicular speed limit, photographs, aerial map.
3. A detailed explanation of the necessity of the crossing.

4. Identify at-grade crossings to be closed. Include their vehicular speed limit, AADT, and traffic type.
5. The terms on which the project sponsor proposes that the crossing shall be constructed and subsequently maintained.
6. The determination by the highway or regulatory authority of the need for passive or active traffic control devices and other safety treatments (i.e., signage, roadway medians, etc.), as selected by the highway authority consistent with applicable federal and state MUTCD guidelines and requirements.
7. A plan to satisfy any appropriate regulatory authority's requirements, procedures and approval. The project sponsor should coordinate with all applicable agencies (state, county, city, etc.) to ensure proper procedures are followed.
8. Provide CSXT authorization to incur costs for its Preliminary Engineering to review the crossing request (whether or not is approved), design and construction expenses, and for the ongoing maintenance of the crossing surface and related grade crossing warning devices.

CSXT will review the request for a new crossing and inform the project sponsor whether or not the new crossing is approved. CSXT may deny a new crossing request due to safety or operational concerns.



Bicycle/Pedestrian Pathways and Multi-Use Trails

Key Points

- Private or public parallel bicycle/pedestrian pathways and trails are not permitted on CSXT property.
- Bicycle/pedestrian pathways and trails cannot cross tracks at grade outside of existing highway easements.
- The highway agency's design must include additional safety measures for at-grade pathways and trails within existing highway easements.
- CSXT prefers grade separated bicycle/pedestrian pathways and multi-use trails.
- CSXT will oppose condemnation proceedings aimed at recreational use of trackside property.

Overview

CSXT recognizes that communities often wish to establish recreational pathways and trails in the proximity of active railroad lines. While CSXT will work with communities to accommodate such requests, it is critical for project sponsors to recognize that CSXT requirements must be met and safety precautions taken to protect the public and CSXT employees. In addition, certain requests, such as pathway crossings at grade outside of existing highway easements, will not be permitted.

CSXT Policy on Pathways and Trails Parallel to CSXT Property

At CSXT safety is paramount. CSXT's policy is not to permit private or public parallel bicycle/pedestrian paths that come within the railroad's right-of-way. CSXT will insist upon safety measures such as fencing and signage where such pathways or parks are established parallel to the railroad's right-of-way. The cost of installing, inspection and future maintenance are the responsibility of the trail sponsor or agency. CSXT will oppose any attempt to establish recreational usage of CSXT property through condemnation. Regardless of construction of pathways and trails, CSXT reserves the right to use CSXT right of way for operational necessities.

Pathways and Trails Crossing CSXT Tracks and Right-of-Way

Bicycle/pedestrian pathways and trails cannot cross tracks at grade outside of existing highway easements. Grade separated pathway and trail crossings are preferred in all cases, and required when outside of an existing highway easement. Pathways and trails under existing railroad structures are discouraged and will only be allowed under special circumstances. Pathways and trails over and under the railroad track shall have protective fencing.

Bicycle/pedestrian pathways and trails crossing at-grade within a highway easement must have appropriate signs and warning systems as determined by the responsible highway and/or regulatory agency.

All expenses associated with the design, installation and maintenance of the pathway/trail, including the costs of signs, crossing surfaces and warning systems associated with an at-grade crossing, will be paid by the project sponsor.

CSXT prosecutes trespassers and every precaution must be taken to ensure that the public remains clear of CSXT's property.



Quiet Zones Proposals

Key Points

- This section was developed as a guideline for communities that approach CSXT in regards to the implementation of a Quiet Zone under the Federal Railroad Administration's (FRA) final rule on the use of locomotive horns at public highway-rail grade crossings (49 CFR Part 222, the "Rule"), and to ensure CSXT's full compliance and cooperation with respect to the Rule.
- According to the FRA, the implementation of Quiet Zones – without appropriate safeguards and equipment – increases the risk of accidents at highway-rail grade crossings. In this context, CSXT encourages communities considering whether to pursue the implementation of a Quiet Zone to take into account the installation of appropriate Supplemental Safety Measures ("SSMs"), as defined in the Rule, as well as the consolidation and/or closing of adjacent crossings, all of which will act as a safeguard to potentially reduce the risk of accidents at each crossing below the risk level that existed prior to the implementation of the Quiet Zone.
- Communities that wish to implement Quiet Zones will be required to strictly comply with the Rule.
- Pursuant to the Rule, notifications and/or applications to implement or continue Quiet Zones are to be made to the FRA and must involve all relevant state and local agencies, CSXT, and any other rail carriers operating in the area.
- CSXT will seek to be reimbursed for work performed to design, implement, and maintain railroad facilities within Quiet Zones.
- CSXT desires to be a good corporate citizen. CSXT also places importance on the quality and timeliness of service to its customers and the communities it serves. As such, consistent with the Rule, CSXT will seek to encourage communities requesting Quiet Zones to implement solutions and SSMs that optimally achieve safety while minimizing the impact on railroad operations.

Overview

CSXT will fully comply with the Rule, which provides requirements for the sounding of locomotive horns when approaching public highway-rail grade crossings. The Rule also provides guidance for conditions under which a public authority with jurisdiction over the roadway crossing CSXT tracks may apply for and establish Quiet Zones. A Quiet Zone is a section of a rail line that contains one or more consecutive public crossings at which locomotive horns are not routinely sounded. (For full details on the rules, CSXT recommends that communities either visit the FRA web site at www.fra.dot.gov or contact the FRA's Office of Safety at 202-493-6299).

Policy on Quiet Zones

The Rule clearly defines requirements that must be satisfied by the public authority requesting that a Quiet Zone be established or continued. CSXT will expect the public authority to strictly comply with these requirements.

Identification of the crossing and location

Each crossing has a unique DOT inventory identification number posted at the crossing. There is often more than one crossing on the same road. The crossing number (such as 123456A) must be used to identify the specific crossing in all communications with the railroad to reduce possible confusion about the specific location.

Preliminary Planning for Quiet Zones

Preliminary work by CSXT personnel and/or its consultants is likely to be required in connection with the proposed new or continued Quiet Zone, including, but not limited to: updating crossing inventory information; attending meetings; participating, to the extent feasible, in diagnostic reviews of the public, private and pedestrian crossings in a proposed Quiet Zone; preparing and processing estimates covering the cost of work to be performed by CSXT, if applicable; and processing necessary agreements. CSXT will coordinate preliminary planning activities with each public authority pursuant to an initial agreement that will also provide for payment to CSXT for services provided during development of Quiet Zones.

Getting Started: Process for Pursuing a Quiet Zone

1. Groups or individuals interested in Quiet Zones should first contact the public authority responsible for the highway where the Quiet Zone would be located. Public authorities should then contact the FRA for additional information on Quiet Zone requirements and procedures.
2. The public authority shall initiate contact with CSXT to: TellCSX@csx.com or (877) 835-5279. Those making this contact will be furnished with the Quiet Zone policy and advised of the appropriate contact within the CSXT Public Projects Group for the initial planning activities with CSXT.
3. If the public authority decides to proceed with preliminary planning for a Quiet Zone, CSX will assist by providing, when required, DOT inventory information and attending diagnostic review meetings, to the extent schedules permit. CSXT resources to attend these meetings are limited and thus CSXT will seek flexibility in establishing meeting dates and times in order to permit CSXT representatives to attend.
4. The preliminary planning for a Quiet Zone project should include a review of the following principles:
 - a. CSXT will cooperate and work in good faith with local communities and the appropriate public authority to provide all possible assistance in a manner that protects the safety of local citizens and their communities as well as CSXT's employees.
 - b. In accordance with the Rule, CSXT's support of a Quiet Zone proposal will require the plan to meet very specific FRA measures and requirements, which in some cases, may be subject to FRA review, approval and on-going oversight. Accordingly, CSXT retains the right to review and comment on the requests.
 - c. CSXT expects the involvement of the state DOT, FRA, and/or state regulatory authority in any diagnostic review of a public, private and pedestrian crossing in the Quiet Zone corridor being proposed.
 - d. As discussed above, the appropriate public authority will be expected to reimburse CSXT for its cost of design, installation and future maintenance of safety enhancements, including, but not limited to, its installation of Supplemental Safety Measures (SSMs) and Alternative Safety Measures (ASMs). As an example, CSXT installs and maintains active warning systems at highway-rail grade crossings that may be modified or expanded for a Quiet Zone. Curbs, medians, pavement markings and other traffic control signs such as advance warning signs are installed and maintained by Public Authorities. The specific responsibilities are expected to be resolved during the preliminary planning for a Quiet Zone.
 - e. If one or more SSMs or ASMs selected to be installed require work by CSXT, a separate standard Preliminary Engineering Agreement will be required to cover CSXT's engineering, review, handling, and estimate preparation connected with the proposed work. A separate Construction Agreement will be used for implementation of the projects. The cost of this work will be the responsibility of the requesting public authority.
 - f. SSMs or ASMs installed and maintained by the public authority as described above are important parts of traffic control at each crossing. The Public authority is responsible for periodic inspection and repair of these items.
5. Standard CSXT Public Projects Group design and estimating procedures will be used for projects related to Quiet Zones.
6. Vehicle Loop Detection Circuitry will not be designed, installed, owned, or maintained by CSXT.
7. Wayside Horn Systems are not authorized for use on CSXT.

APPENDIX

CSX Transportation

PRELIMINARY ENGINEERING AGREEMENT

Public Projects Group
Jacksonville, FL
Date Issued: May 12, 2006

PRELIMINARY ENGINEERING AGREEMENT

This Preliminary Engineering Agreement (this "Agreement") is made as of _____, 20__, by and between CSX TRANSPORTATION, INC., a Virginia corporation with its principal place of business in Jacksonville, Florida ("CSXT"), and [insert name of public agency], a body corporate and political subdivision of the [State or Commonwealth] of [insert name of State/Commonwealth] ("Agency").

EXPLANATORY STATEMENT

1. Agency wishes to facilitate the development of the proposed [DESCRIBE PROJECT] (the "Project").
2. Agency has requested that CSXT proceed with certain necessary engineering and/or design services for the Project to facilitate the parties' consideration of the Project.
3. Subject to the approval of CSXT, which approval may be withheld for any reason directly or indirectly related to safety or CSXT operations, property, or facilities, the Project is to be constructed, if at all, at no cost to CSXT, under a separate construction agreement to be executed by the parties at a future date.

NOW, THEREFORE, for and in consideration of the foregoing Explanatory Statement and other good and valuable consideration, the receipt and sufficiency of which are acknowledged by the parties, the parties agree as follows:

1. Scope of Work

1.1 Generally. The work to be done by CSXT under this Agreement shall consist of: (i) the preparation or review and approval of preliminary and final engineering and design plans, specifications, drawings, agreements and other documents pertaining to the Project, (ii) the preparation of cost estimates for CSXT's work in connection with the Project, and (iii) the review of construction cost estimates, site surveys, assessments, studies, agreements and related construction documents submitted to CSXT by Agency for the Project (collectively, the "Engineering Work"). Engineering Work may also include office reviews, field reviews, attending hearings and meetings, and preparing correspondence, reports, and other documentation in connection with the Project. Nothing contained in this Agreement shall oblige CSXT to perform work which, in CSXT's opinion, is not relevant to CSXT's participation in the Project.

1.2 Effect of CSXT Approval or Preparation of Documents. By its review, approval or preparation of plans, specifications, drawings or other documents pursuant to this Agreement (collectively, the "Plans"), CSXT signifies only that the Plans and the Project proposed to be constructed in accordance with the Plans satisfy CSXT's requirements. CSXT expressly disclaims all other representations and warranties in connection with the Plans, including, but not limited to, the integrity, suitability or fitness for the purposes of Agency or any other persons of such Plans or the Project constructed in accordance with the Plans.

2. Project Construction. Nothing contained in this Agreement shall be deemed to constitute CSXT's approval of or consent to the construction of the Project, which approval or consent may be withheld for any reason directly or indirectly related to safety or CSXT operations, property, or facilities. The Project if constructed is to be constructed, if at all, under a separate construction agreement to be executed by the parties at a future date.

3. Reimbursement of CSXT Expenses.

3.1. Reimbursable Expenses. Agency shall reimburse CSXT for all costs and expenses incurred by CSXT in connection with the Engineering Work, including, without limitation: (i) all out of pocket expenses, (ii) travel and lodging expenses, (iii) telephone, facsimile, and mailing expenses, (iv) costs for equipment, tools, materials and supplies, (v) sums paid to consultants and subcontractors, and (vi) labor, together with labor overhead percentages established by CSXT pursuant to applicable law (collectively, the "Reimbursable Expenses").

3.2 Estimate. CSXT has estimated the total Reimbursable Expenses for the Project to be approximately \$_____ (the "Estimate" as amended or revised). In the event CSXT anticipates that actual Reimbursable Expenses may exceed such Estimate, it shall provide Agency with the revised Estimate of total Reimbursable Expenses for Agency's approval and confirmation that sufficient funds have been appropriated to cover the total Reimbursable Expenses as reflected in the revised Estimate. CSXT may elect, by delivery of notice to Agency, to immediately cease all further Engineering Work, unless and until Agency provides such approval and confirmation.

3.3 Payment Terms.

3.3.1. Advance Payment in Full. Upon execution and delivery of this Agreement by Agency, Agency will deposit with CSXT a sum equal to the Reimbursable Expenses, as shown by the Estimate. Agency shall pay CSXT for Reimbursable Expenses in the amount set forth in CSXT Schedule PA attached hereto, a copy of which shall accompany the advance payment. If CSXT anticipates that it may incur Reimbursable Expenses in excess of the deposited amount, CSXT will request an additional deposit equal to the then remaining Reimbursable Expenses which CSXT estimates that it will incur. CSXT shall request such additional deposit by delivery of invoices to Agency. Agency shall make such additional deposit within thirty (30) days following delivery of such invoice to Agency.

3.3.2. Following completion of all Engineering Work, CSXT shall reconcile the total Reimbursable Expenses incurred by CSXT against the total payments received from Agency and shall submit to Agency a final invoice if required. Agency shall pay to CSXT the amount by which actual Reimbursable Expenses exceed total payments, as shown by the final invoice, within thirty (30) days following delivery to Agency of the final invoice. CSXT will provide a refund of any unused deposits if the deposit exceeds the incurred Reimbursable Expenses for the Project.

3.3.3. In the event that Agency fails to pay CSXT any sums due CSXT under this Agreement: (i) Agency shall pay CSXT interest at the lesser of 1.0% per month or the maximum rate of interest permitted by applicable law on the delinquent amount until paid in full; and (ii) CSXT may elect, by delivery of notice to Agency: (A) to immediately cease all further work on the Project, unless and until Agency pays the entire delinquent sum, together with accrued interest; and/or (B) to terminate this Agreement.

3.4 Effect of Termination. Agency's obligation to pay CSXT Reimbursable Expenses in accordance with this Section shall survive termination of this Agreement for any reason.

4. Appropriations. Agency represents to CSXT that: (i) Agency has obtained appropriations sufficient to reimburse CSXT for the Reimbursable Expenses encompassed by the initial Estimate; (ii) Agency shall use its best efforts to obtain appropriations necessary to cover Reimbursable Expenses encompassed by subsequent Estimates approved by Agency; and (iii) Agency shall promptly notify CSXT in the event that Agency is unable to obtain such additional appropriations.

5. Termination.

5.1 By Agency. Agency may terminate this Agreement, for any reason, by delivery of notice to CSXT. Such termination shall become effective upon the expiration of fifteen (15) calendar days following delivery of notice to CSXT or such later date designated by the notice.

5.2 By CSXT. CSXT may terminate this Agreement (i) as provided pursuant to Section 3.3.3., or (ii) upon Agency's breach of any of the terms of, or its obligations under, this Agreement and such breach continues without cure for a period of ninety (90) days after written notification from CSXT to Agency of such breach.

5.3 Consequences of Termination. If the Agreement is terminated by either party pursuant to this Section or any other provision of this Agreement, the parties understand that it may be impractical to immediately stop the Engineering Work. Accordingly, both parties agree that, in such instance a party may continue to perform Engineering Work until it

has reached a point where it may reasonably and/or safely suspend the Engineering Work. Agency shall reimburse CSXT pursuant to this Agreement for the Engineering Work performed, plus all costs reasonably incurred by CSXT to discontinue the Engineering Work and all other costs of CSXT incurred as a result of the Project up to the time of full suspension of the Engineering Work. Termination of this Agreement or Engineering Work on the Project, for any reason, shall not diminish or reduce Agency's obligation to pay CSXT for Reimbursable Expenses incurred in accordance with this Agreement. In the event of the termination of this Agreement or the Engineering Work for any reason, CSXT's only remaining obligation to Agency shall be to refund to Agency payments made to CSXT in excess of Reimbursable Expenses in accordance with Section 2.

6. Subcontracts. CSXT shall be permitted to engage outside consultants, counsel and subcontractors to perform all or any portion of the Engineering Work.

7. Notices. All notices, consents and approvals required or permitted by this Agreement shall be in writing and shall be deemed delivered (i) on the expiration of three (3) days following mailing by first class U.S. mail, (ii) on the next business day following mailing by a nationally recognized overnight carrier, or (iii) on the date of transmission, as evidenced by written confirmation of successful transmission, if by facsimile or other electronic transmission if sent on a business day (or if not sent on a business day, then on the next business day after the date sent), to the parties at the addresses set forth below, or such other addresses as either party may designate by delivery of prior notice to the other party:

If to CSXT: CSX Transportation, Inc.
500 Water Street, J301
Jacksonville, Florida 32202
Attention: _____

If to Agency: _____

8. Entire Agreement. This Agreement embodies the entire understanding of the parties, may not be waived or modified except in a writing signed by authorized representatives of both parties, and supersedes all prior or contemporaneous written or oral understandings, agreements or negotiations regarding its subject matter. In the event of any inconsistency between this Agreement and the Exhibits, the more specific terms of the Exhibits shall be deemed controlling.

9. Waiver. If either party fails to enforce its respective rights under this Agreement, or fails to insist upon the performance of the other party's obligations hereunder, such failure shall not be construed as a permanent waiver of any rights or obligations in this Agreement.

10. Assignment. CSXT may assign this Agreement and all rights and obligations herein to a successor in interest, parent company, affiliate, or future affiliate. Upon assignment of this Agreement by CSXT and the assumption by CSXT's assignee of CSXT's obligations under this Agreement, CSXT shall have no further obligations under this Agreement. Agency shall not assign its rights or obligations under this Agreement without CSXT's prior written consent, which consent may be withheld for any reason.

11. Applicable Law. This Agreement shall be governed by the laws of the [State or Commonwealth] of [*PROJECT LOCATION], exclusive of its choice of law rules. The parties further agree that the venue of all legal and equitable proceedings related to disputes under this Agreement shall be situated in Duval County, Florida, and the parties agree to submit to the personal jurisdiction of any State or Federal court situated in Duval County, Florida.

IN WITNESS WHEREOF, the parties have caused this Agreement to be executed in duplicate, each by its duly authorized officers, as of the date of this Agreement.

[AGENCY]

By: _____

Print Name: _____

Title: _____

CSX TRANSPORTATION, INC.

By: _____

Print Name: _____

CSXT Schedule PA
(Advance Payment – Preliminary Engineering Agreement)

PAYMENT SUBMISSION FORM

Payment is hereby provided in accordance with the terms of Section 3.3 of the Agreement dated _____,
20____, between Agency and CSXT.

A copy of this Payment Submission Form shall accompany all payments delivered by Agency to CSXT which shall be
forwarded to the following address:

CSX Transportation, Inc.
P. O. Box 116651
Atlanta, GA 30368-6651

Payment due within ten (10) days of Agency's receipt of fully executed agreement

(All information below to be completed by Agency providing Payment)

Payment Date

Payment Amount

Check No.

Date: _____ By: _____

Name: _____

Title: _____

Phone: _____

Email: _____

APPENDIX

CSX Transportation

CONSTRUCTION AGREEMENT

Public Projects Group
Jacksonville, FL
Date Issued: October 1, 1999

CONSTRUCTION AGREEMENT

This Construction Agreement ("Agreement") is made as of _____, 20____, by and between CSX TRANSPORTATION, INC., a Virginia corporation with its principal place of business in Jacksonville, Florida ("CSXT"), and [PUBLIC AGENCY], a body corporate and political subdivision of the State of _____ ("Agency").

EXPLANATORY STATEMENT

1. Agency has proposed to construct, or to cause to be constructed, [PROJECT DESCRIPTION] (the "Project").
2. Agency has obtained, or will obtain, all authorizations, permits and approvals from all local, state and federal agencies (including Agency), and their respective governing bodies and regulatory agencies, necessary to proceed with the Project and to appropriate all funds necessary to construct the Project.
3. Agency acknowledges that: (i) by entering into this Agreement, CSXT will provide services and accommodations to promote public interest in this Project, without profit or other economic inducement typical of other Agency contractors; (ii) neither CSXT nor its affiliates (including their respective directors, officers, employees or agents) will incur any costs, expenses, losses or liabilities in excess of payments made to CSXT, by or on behalf of Agency or its contractors, pursuant to this Agreement; and (iii) CSXT retains the paramount right to regulate all activities affecting its property and operations.
4. It is the purpose of this Agreement to provide for the terms and conditions upon which the Project may proceed.

NOW, THEREFORE, in consideration of the foregoing Explanatory Statement and other good and valuable consideration, the receipt and sufficiency of which are acknowledged by the parties, the parties agree as follows:

1. PROJECT PLANS AND SPECIFICATIONS

Preparation and Approval. Pursuant to Exhibit A of this Agreement, all plans, specifications, drawings and other documents necessary or appropriate to the design and construction of the Project shall be prepared, at Agency's sole cost and expense, by Agency or CSXT or their respective contractors. Project plans, specifications and drawings prepared by or on behalf of Agency shall be subject, at CSXT's election, to the review and approval of CSXT. Such plans, specifications and drawings, as prepared or approved by CSXT, are referred to as the "Plans", and shall be incorporated and deemed a part of this Agreement. Plans prepared or submitted to and approved by CSXT as of the date of this Agreement are set forth in Exhibit B to this Agreement.

Effect of CSXT Approval or Preparation of Plans. By its review, approval or preparation of Plans pursuant to this Agreement, CSXT signifies only that such Plans and improvements constructed in accordance with such Plans and improvements constructed in accordance with such Plans satisfy CSXT's requirements. CSXT expressly disclaims all other representations and warranties in connection with the Plans, including, but not limited to, the integrity, suitability or fitness for the purposes of Agency or any other persons of the Plans or improvements constructed in accordance with the Plans.

Compliance with Plans. The Project shall be constructed in accordance with the Plans.

2. ALLOCATION AND CONDUCT OF WORK

Work in connection with the Project shall be allocated and conducted as follows:

2.1 CSXT Work. Subject to timely payment of Reimbursable Expenses as provided by Section 4, CSXT shall provide, or cause to be provided, the services as set forth by Exhibit A to this Agreement. Agency agrees that CSXT shall provide all services that CSXT deems necessary or appropriate (whether or not specified by Exhibit A) to preserve and maintain its property and operations, without impairment or exposure to liability of any kind and in compliance with all applicable federal, state and local regulations and CSXT's contractual obligations, including, but not limited to, CSXT's existing or proposed third party agreements and collective bargaining agreements.

2.2 Agency Work. Agency shall perform, or cause to be performed, all work as set forth by Exhibit A, at Agency's sole cost and expense.

2.3 Conduct of Work. CSXT shall commence its work under this Agreement following: (i) delivery to CSXT of a notice to proceed from Agency; (ii) payment of Reimbursable Expenses (as provided by Section 4.1) as required by CSXT prior to the commencement of work by CSXT; (iii) issuance of all permits, approvals and authorizations necessary or appropriate for such work; and (iv) delivery of proof of insurance acceptable to CSXT, as required by Section 9. The initiation of any services by CSXT pursuant to this Agreement, including, but not limited to, the issuance of purchase orders or bids for materials or services, shall constitute commencement of work for the purposes of this Section. The parties intend that all work by CSXT or on CSXT property shall conclude no later than [INSERT DATE], unless the parties mutually agree to extend such date.

3. SPECIAL PROVISIONS

Agency shall observe and abide by, and shall require its contractors (“Contractors”) to observe and abide by the terms, conditions and provisions set forth in Exhibit C to this Agreement (the “Special Provisions”). To the extent that Agency performs Project work itself, Agency shall be deemed a Contractor for purposes of this Agreement. Agency further agrees that, prior to the commencement of Project work by any third party Contractor, such Contractor shall execute and deliver to CSXT Schedule I to this Agreement to acknowledge Contractor’s agreement to observe and abide by the terms and conditions of this Agreement.

4. COST OF PROJECT AND REIMBURSEMENT PROCEDURES

4.1 Reimbursable Expenses. Agency shall reimburse CSXT for all costs and expenses incurred by CSXT in connection with the Project, including, without limitation: (1) all out of pocket expenses, (2) travel and lodging expenses, (3) telephone, facsimile, and mailing expenses, (4) costs for equipment, tools, materials and supplies, (5) sums paid to CSXT’s consultants and subcontractors, and (6) CSXT labor in connection with the Project, together with CSXT labor overhead percentages established by CSXT pursuant to applicable law (collectively, “Reimbursable Expenses”). Reimbursable Expenses shall also include expenses incurred by CSXT prior to the date of this Agreement to the extent identified by the Estimate provided pursuant to Section 4.2.

4.2 Estimate. CSXT has estimated the total Reimbursable Expenses for the Project as shown on Exhibit D (the “Estimate”, as amended or revised). In the event CSXT anticipates that actual Reimbursable Expenses for the Project may exceed such Estimate, it shall provide Agency with the revised Estimate of the total Reimbursable Expenses, together with a revised Payment Schedule (as defined by Section 4.3.1), for Agency’s approval and confirmation that sufficient funds have been appropriated to cover the total Reimbursable Expenses of such revised Estimate. CSXT may elect, by delivery of notice to Agency, to immediately cease all further work on the Project, unless and until Agency provides such approval and confirmation.

4.3 Payment Terms.

4.3.1 Agency shall pay CSXT for Reimbursable Expenses in the amounts and on the dates set forth in the Payment Schedule as shown on Exhibit E (the “Payment Schedule”, as revised pursuant to Section 4.2). CSXT agrees to submit invoices to Agency for such amounts and Agency shall remit payment to CSXT at the later of thirty (30) days following delivery of each such invoice to Agency or, the payment date (if any) set forth in the Payment Schedule.

4.3.2 Following completion of the Project, CSXT shall submit to Agency a final invoice that reconciles the total Reimbursable Expenses incurred by CSXT against the total payments received from Agency. Agency shall pay to CSXT the amount by which Reimbursable Expenses exceed total payments as shown by the final invoice, within thirty (30) days following delivery of such invoice to Agency. In the event that the payments received by CSXT from Agency exceed the Reimbursable Expenses, CSXT shall remit such excess to Agency.

4.3.3 In the event that Agency fails to pay CSXT any sums due CSXT under this Agreement: (i) Agency shall pay CSXT interest at the lesser of 1.0% per month or the maximum rate of interest permitted by applicable law on the delinquent amount until paid in full; and (ii) CSXT may elect, by delivery of notice to Agency: (A) to immediately cease all further work on the Project, unless and until Agency pays the entire delinquent sum, together with accrued interest; and/or (B) to terminate this Agreement.

4.3.4 All invoices from CSXT shall be delivered to Agency in accordance with Section 16 of this Agreement. All payments by Agency to CSXT shall be made by certified check and mailed to the following address or such other address as designated by CSXT's notice to Agency:

CSX Transportation, Inc.
P. O. Box 116551
Atlanta, GA 30368-6651

4.4 Effect of Termination. Agency's obligation to pay to CSXT Reimbursable Expenses in accordance with Section 4 shall survive termination of this Agreement for any reason.

5. APPROPRIATIONS

Agency represents to CSXT that: (i) Agency has appropriated funds sufficient to reimburse CSXT for the Reimbursable Expenses encompassed by the Estimate attached as Exhibit D; (ii) Agency shall use its best efforts to obtain appropriations necessary to cover Reimbursable Expenses encompassed by subsequent Estimates approved by Agency; and (iii) Agency shall promptly notify CSXT in the event that Agency is unable to obtain such appropriations.

6. EASEMENTS AND LICENSES

6.1 Agency Obligation. Agency shall acquire all necessary licenses, permits and easements required for the Project.

6.2 Temporary Construction Licenses. Insofar as it has the right to do so, CSXT hereby grants Agency a nonexclusive license to access and cross CSXT's property, to the extent necessary for the construction of the Project (excluding ingress or egress over public grade crossings), along such routes and upon such terms as may be defined and imposed by CSXT and such temporary construction easements as may be designated on the Plans approved by CSXT.

Permanent Easements. Insofar as it has the right to do so, CSXT shall grant, without warranty to Agency, easements for the use and maintenance of the Project wholly or partly on CSXT property as shown on the Plans approved by CSXT, if any, on terms and conditions and at a price acceptable to the parties. Upon request by CSXT, Agency shall furnish to CSXT descriptions and plat plans for the easements.

7. PERMITS

At its sole cost and expense, Agency shall procure all permits and approvals required by any federal, state, or local governments or governmental agencies for the construction, maintenance and use of the Project, copies of which shall be provided to CSXT.

8. TERMINATION

8.1 By Agency. For any reason, Agency may, as its sole remedy, terminate this Agreement by delivery of notice to CSXT. Agency shall not be entitled to otherwise pursue claims for consequential, direct, indirect or incidental damages or lost profits as a consequence of CSXT's default or termination of this Agreement or Work on the Project by either party.

8.2 By CSXT. In addition to the other rights and remedies available to CSXT under this Agreement, CSXT may terminate this Agreement by delivery of notice to Agency in the event Agency or its Contractors fail to observe the terms or conditions of this Agreement and such failure continues more than ten (10) business days following delivery of notice of such failure by CSXT to Agency.

8.3 Consequences of Termination. If the Agreement is terminated by either party pursuant to this Section or any other provision of this Agreement, the parties understand that it may be impractical for them to immediately stop the Work. Accordingly, they agree that, in such instance a party may continue to perform Work until it has reached a point where it may reasonably and safely suspend the Work. Agency shall reimburse CSXT pursuant to this Agreement for the Work performed, plus all costs reasonably incurred by CSXT to discontinue the Work and protect the Work upon full suspension of the same, the cost of returning CSXT's property to its former condition, and all other costs of CSXT incurred as a result of the Project up to the time of full suspension of the Work. Termination of this Agreement or Work on the Project, for any reason, shall not diminish or reduce Agency's obligation to pay CSXT for Reimbursable Expenses incurred in accordance with this Agreement. In the event of the termination of this Agreement or the Work for any reason, CSXT's only remaining obligation to Agency shall be to refund to Agency payments made to CSXT in excess of Reimbursable Expenses in accordance with Section 4.

9. INSURANCE

In addition to the insurance that Agency requires of its Contractor, Agency shall acquire or require its Contractor to purchase and maintain insurance in compliance with CSXT's insurance requirements attached to this Agreement as Exhibit F. Neither Agency nor Contractor shall commence work on the Project until such policy or policies have been submitted to and approved by CSXT's Risk Management Department.

10. OWNERSHIP AND MAINTENANCE

[CSXT UTILIZES VARIOUS LANGUAGE IN COMPLETING THIS SECTION DESCRIBING BOTH MAINTENANCE RESPONSIBILITIES FOR CSXT AND AGENCY WHICH IS DEPENDENT UPON THE PROJECT WORK SCOPE, PROVISIONS OF LAW OR REGULATORY ORDERS, PROJECT NEGOTIATIONS AND OTHER FACTORS – FINAL LANGUAGE TO BE DETERMINED]

10.1 By Agency.

10.2 By CSXT.

10.3 Alterations. Agency shall not undertake any alteration, modification or expansion of the Project, without the prior written approval of CSXT, which may be withheld for any reason, and the execution of such agreements as CSXT may require.

11. INDEMNIFICATION

11.1 Generally. To the maximum extent permitted by applicable law, Agency and its Contractors shall indemnify, defend, and hold CSXT and its affiliates harmless from and against all claims, demands, payments, suits, actions, judgments, settlements, and damages of every nature, degree, and kind (including direct, indirect, consequential, incidental, and punitive damages), for any injury to or death to any person(s) (including, but not limited to the employees of CSXT, its affiliates, Agency or its Contractors), for the loss of or damage to any property whatsoever (including but not limited to property owned by or in the care, custody, or control of CSXT, its affiliates, Agency or its Contractors, and environmental damages and any related remediation brought or recovered against CSXT and its affiliates), arising directly or indirectly from the negligence, recklessness or intentional wrongful misconduct of the Contractors, Agency, and their respective agents, employees, invitees, contractors, or its contractors' agents, employees or invitees in the performance of work in connection with the Project or activities incidental thereto, or from their presence on or about CSXT's property. The foregoing indemnification obligation shall not be limited to the insurance coverage required by this Agreement, except to the extent required by law or otherwise expressly provided by this Agreement.

11.2 Compliance with Laws. Agency shall comply, and shall require its Contractors to comply, with any federal, state, or local laws, statutes, codes, ordinances, rules, and regulations applicable to its construction and maintenance of the Project. Agency's Contractors shall indemnify, defend, and hold CSXT and its affiliates harmless with respect to any fines, penalties, liabilities, or other consequences arising from breaches of this Section.

11.3 "CSXT Affiliates". For the purpose of this Section 11, CSXT's affiliates include CSX Corporation and all entities, directly or indirectly, owned or controlled by or under common control of CSXT or CSX Corporation and their respective officers, directors, employees and agents.

11.4 Notice of Incidents. Agency and its Contractor shall notify CSXT promptly of any loss, damage, injury or death arising out of or in connection with the Project work.

11.5 Survival. The provisions of this Section 11 shall survive the termination or expiration of this Agreement.

12. INDEPENDENT CONTRACTOR

The parties agree that neither Agency nor its Contractors shall be deemed either agents or independent contractors of CSXT. Except as otherwise provided by this Agreement, CSXT shall exercise no control whatsoever over the employment, discharge, compensation of, or services rendered by Agency or Agency's Contractors, or the construction practices, procedures, and professional judgment employed by Agency or its Contractor to complete the Project. Notwithstanding the foregoing, this Section 12 shall in no way affect the absolute authority of CSXT to prohibit Agency or its Contractors or anyone from entering CSXT's property, or to require the removal of any person from its property, if it determines, in its sole discretion, that such person is not acting in a safe manner or that actual or potential hazards in, on or about the Project exist.

13. "ENTIRE AGREEMENT"

This Agreement embodies the entire understanding of the parties, may not be waived or modified except in a writing signed by authorized representatives of both parties, and supersedes all prior or contemporaneous written or oral understandings, agreements or negotiations regarding its subject matter. In the event of any inconsistency between this Agreement and the Exhibits, the more specific terms of the Exhibits shall be deemed controlling.

14. WAIVER

If either party fails to enforce its respective rights under this Agreement, or fails to insist upon the performance of the other party's obligations hereunder, such failure shall not be construed as a permanent waiver of any rights or obligations in this Agreement.

15. ASSIGNMENT

CSXT may assign this Agreement and all rights and obligations herein to a successor in interest, parent company, affiliate, or future affiliate. Upon assignment of this Agreement by CSXT and the assumption of CSXT's assignee of CSXT's obligations under this Agreement, CSXT shall have no further obligation under this Agreement. Agency shall not assign its rights or obligations under this Agreement without CSXT's prior consent, which consent may be withheld for any reason.

16. NOTICES

All notices, consents and approvals required or permitted by this Agreement shall be in writing and shall be deemed delivered upon personal delivery, upon the expiration of three (3) days following mailing by first class U.S. mail, or upon the next business day following mailing by a nationally recognized overnight carrier, to the parties at the addresses set forth below, or such other addresses as either party may designate by delivery of prior notice to the other party:

If to CSXT:

If to Agency:

17. SEVERABILITY

The parties agree that if any part, term or provision of this Agreement is held to be illegal, unenforceable or in conflict with any applicable federal, state, or local law or regulation, such part, term or provision shall be severable, with the remainder of the Agreement remaining valid and enforceable.

18. APPLICABLE LAW

This Agreement shall be governed by the laws of the State of _____, exclusive of its choice of law rules. The parties further agree that the venue of all legal and equitable proceedings related to disputes under this Agreement shall be situated in Duval County, Florida, and the parties agree to submit to the personal jurisdiction of any State or Federal court situated in Duval County, Florida.

IN WITNESS WHEREOF, the parties have caused this Agreement to be executed in duplicate, each by its duly authorized officers, as of the date of this Agreement.

[PUBLIC AGENCY]

By _____

Print Name _____

Title _____

CSX TRANSPORTATION, INC.

By _____

Print Name _____

Title _____

EXHIBIT A

ALLOCATION OF WORK

Subject to Section 2.1, work to be performed in connection with the Project is allocated as follows:

A. Agency shall let by contract to its Contractors:

CSXT shall perform or cause to be performed:

EXHIBIT B

PLANS AND SPECIFICATIONS

Plans, Specifications and Drawings:

As of the date of this Agreement, the following plans, specifications and drawings have been submitted by Agency to CSXT for its review and approval:

[INSERT PLAN DESCRIPTION HERE]

EXHIBIT C

CSXT SPECIAL PROVISIONS

EXHIBIT D

INITIAL ESTIMATE

EXHIBIT E PAYMENT SCHEDULE

Advance Payment in Full

Upon execution and delivery of notice to proceed with the Project, Agency will deposit with CSXT a sum equal to the Reimbursable Expenses, as shown by the Estimate. If CSXT anticipates that it may incur Reimbursable Expenses in excess of the deposited amount, CSXT will request an additional deposit equal to the then remaining Reimbursable Expenses which CSXT estimates that it will incur. CSXT shall request such additional deposit by delivery of invoices to Agency. Agency shall make such additional deposit within 30 days following delivery of such invoice to Agency

[NOTE: ALTERNATE PAYMENT PROVISIONS MAY BE ABLE TO BE CONSIDERED BY CSXT IF DEEMED ACCEPTABLE AND ARE SUBJECT TO NEGOTIATION BETWEEN CSXT AND AGENCY]

EXHIBIT F
INSURANCE REQUIREMENTS

SCHEDULE I

CONTRACTOR'S ACCEPTANCE

To and for the benefit of CSX Transportation, Inc. ("CSXT") and to induce CSXT to permit Contractor on or about CSXT's property for the purposes of performing work in accordance with the Agreement dated _____, 20__, between [PUBLIC AGENCY] and CSXT, Contractor hereby agrees to abide by and perform all applicable terms of the Agreement, including, but not limited to Exhibits C and F to the Agreement, and Sections 3, 9 and 11 of the Agreement.

Contractor: _____

By: _____

Name: _____

Title: _____

Date: _____

APPENDIX

CSX Transportation

TEMPORARY RIGHT OF ENTRY AGREEMENT

Public Projects Group
Jacksonville, FL
Date Issued: September 9, 2014

CSX Transportation, Inc.
Temporary Right of Entry Agreement

THIS AGREEMENT, made as of _____, 20____, by and between CSX TRANSPORTATION, INC., a Virginia corporation, whose mailing address is 500 Water Street, Jacksonville, Florida 32202, hereinafter called "**CSXT**," and (****), whose mailing address is (****), hereinafter called "**Licensee**," WITNESSETH:

WHEREAS, Licensee has submitted a written application to CSXT requesting permission to enter CSXT's property located within the (****) Division, (****) Subdivision, at DOT#: (****) MP (****). (STREET NAME) in(CITY), (COUNTY) County, (STATE), (the "**Property**"), for the purpose of (PROJECT DESCRIPTION), beginning (**) feet from the (****)right of way, (the "**Project**"); and

WHEREAS, CSXT is willing to grant to Licensee the limited right and permission to enter upon the Property for the limited purpose of performing the Project.

NOW THEREFORE, CSXT hereby grants to Licensee the right and permission to enter upon the Property for the purpose of performing said Project, subject to the terms and conditions set forth below:

1. PROJECT: The Project shall be performed at the entire cost and expense of Licensee, in accordance with good and sound engineering practices, to the satisfaction of CSXT's Division Engineer or his or her duly authorized representative ("Division Engineer") and in a manner to avoid accidents, damages, unnecessary delays to or interference with train traffic of CSXT. Prior to entry, Licensee shall notify the Division Engineer's representative and arrange for flagging protection in accordance to Sections 5 and 6 of this Agreement. Licensee shall not dig in the ballast line or within the tracks loading influence area, or otherwise disturb the track structure. Licensee and Licensee's employees, agents, contractors and other representatives (collectively, "Agents") shall maintain in their possession a copy of this Agreement at all times during their occupation of the Property.

2. INDEMNITY:

2.1 Licensee hereby assumes risk of and agrees to indemnify, defend, protect and save CSXT and CSXT's Affiliates harmless with respect to any and all attorneys' fees, liability, claims, demands, payments, suits, actions, recoveries, penalties, costs, legal expenses, judgments, settlements, and damages of every nature, degree, and kind (including direct, indirect, consequential, incidental, and punitive damages) for:

2.1.1 personal injury, including, but not limited to bodily injury to or death of any person or persons whomsoever, including the agents, servants, Affiliates or employees of the parties;

2.1.2 the loss or damage to any property whatsoever, including property owned or in the care, custody or control of the parties hereto or their respective Affiliates;

2.1.3 any environmental damage and any related remediation brought or recovered against CSXT or any of its Affiliates; and

2.1.4 any and all other losses or damages; arising directly or indirectly from the presence of Licensee or its Agents on or about the Property, whether or not attributable in whole or part to the negligence, gross negligence, or intentional misconduct of CSXT or its Affiliates.

2.2 The parties waive any and all right or opportunity to contest the enforceability of this Section and agree that, in the event this Section, or any part of this Section, is found unenforceable by the final, unappealable judgment of a court of competent jurisdiction, this Section shall be construed so as to be enforceable to the maximum extent permitted by applicable law. In the event that such court of competent jurisdiction finds that Florida statutory construction contract indemnity monetary limits apply to this Agreement with respect to Licensee's indemnification of CSXT and its Affiliates for liability caused in whole or in part by any act, omission or default by CSXT or its Affiliates, the parties hereto agree that such limit shall be equal to the limits (exclusive of deductibles) of the applicable insurance required by Sections 3 and 4 of this Agreement. The parties acknowledge and agree that this monetary limit, if required, bears a commercially reasonable relationship to this Agreement, in so far as, among other factors, the parties have taken into account the availability and cost of insurance and other risk transference devices, the scope of the Project, the risks associated with the Project, and the compensation and any other benefits exchanged between the parties in connection with this Agreement.

2.2.1 Licensee shall comply with any federal, state, or local laws, statutes, codes, ordinances, rules,

and regulations applicable to its presence or performance of any activity on the Property and agrees to indemnify, defend, and hold CSXT and its Affiliates harmless with respect to any fines, penalties, liabilities, or other consequences for its failure to so comply.

2.2.2 For the purpose of this Agreement, the term "Affiliates" includes all entities, directly or indirectly owned or controlled by, or under common control of a party or its respective officers, directors, employees and agents, and in the case of CSXT, includes CSX Corporation, CSXT and their Affiliates and their respective officers, directors, employees and agents.

2.2.3 The provisions of this Section shall survive the termination or expiration of this Agreement.

3. GENERAL LIABILITY INSURANCE: Licensee shall procure and maintain, at its expense: (i) statutory Worker's Compensation and Employers Liability Insurance with available limits of not less than \$1,000,000.00, which insurance must contain a waiver of subrogation against CSXT and its Affiliates; (ii) Commercial General Liability coverage (inclusive of contractual liability) with available limits of not less than \$5,000,000.00 in combined single limits for bodily injury and property damage and covering the contractual liabilities assumed under this Agreement; (iii) business automobile liability insurance with available limits of not less than \$1,000,000.00 combined single limit for bodily injury and/or property damage per occurrence; and (iv) such other insurance as CSXT may reasonably require. Upon request, Licensee shall provide CSXT with a copy of Licensee's applicable insurance policies. A policy endorsement naming CSXT as an additional insured and specifying such coverage shall be furnished to CSXT prior to the execution of this Agreement, and the required coverage will be kept in force until all of Licensee's obligations under this Agreement have been fully discharged and fulfilled, or until Licensee shall have been specifically released by a written instrument signed by an authorized officer of CSXT. Licensee shall also provide CSXT with a copy of the insurance policies. The insurance policies shall provide that the insurance carrier must give CSXT notice at least thirty (30) days in advance of cancellation of coverage, of any change in coverage, or of cancellation of the policy. Notwithstanding any provisions of this Section, the liability assumed by Licensee shall not be limited to the required insurance coverage.

4. RAILROAD PROTECTIVE LIABILITY INSURANCE: Licensee agrees to purchase Railroad Protective Liability Insurance in accordance with CSXT's requirements (attached as Exhibit A and incorporated into this Agreement) for the benefit of CSXT for Licensee's operations under this Agreement. Licensee shall furnish an appropriate Insurance policy (and required endorsements), as the case may be, with the return of this executed Agreement.

5. PRIOR NOTIFICATION: Licensee or Licensee's Agents shall notify CSXT's Roadmaster at least 10 days prior to requiring entry on the Property and shall abide by the instructions of the Division Engineer, or his or her authorized representative. The Roadmaster, (*****), can be contacted at: (*****), to schedule flagging services.

6. CLEARANCES: Neither Licensee nor Agents shall perform any Project or place or operate any equipment of Licensee or Agents at a distance closer than fifty (50) feet from the center of any track, without the prior approval of the Division Engineer. The Division Engineer may require protective services or such other services as deemed necessary or appropriate. Equipment shall be moved across CSXT's track(s) only at a public crossing unless prior arrangements have been made with the Division Engineer and a Private Crossing Agreement is fully executed and in place. Licensee and Agents shall take all precautions necessary to avoid interference with or damage to CSXT's property and signal and communication facilities during their performance of the Project.

7. PROTECTIVE SERVICES: If protective services, such as flagging protection, are required by CSXT, Licensee shall make arrangements with the Roadmaster to furnish such personnel, flagman or watchman, that in the Roadmaster's opinion may be necessary to protect the facilities and traffic of CSXT during the performance of the Project. Licensee shall pay for the cost of such services, including all applicable surcharges and additives. These services are estimated to be \$_____, as supported by the attached estimate.

8. PAYMENT FOR PROTECTIVE SERVICES: Payment shall be made by Licensee in accordance with the following designated option:

() **Option 1:** Licensee shall make an advance deposit of funds based on an estimate of the cost of protective or other services as determined by CSXT. The cost for CSXT's services shall then be assessed by CSXT against this advance deposit. Upon completion of the Project, any unused funding will be returned to Licensee. If CSXT's costs exceed the advance deposit(s), a request will be made to Licensee for additional funds or an invoice will be issued to Licensee for final payment. Licensee shall remit payment to CSXT within thirty (30) days of receipt of either a request for additional funds or an invoice.

() **Option 2:** Licensee shall promptly reimburse CSXT for the cost of protective or other services on an as-incurred basis, including all applicable surcharges, upon receipt of bill(s) therefor.

9. ENVIRONMENTAL: This Agreement does not include and expressly excludes the performance of any site investigation activities designed to determine environmental conditions on, about or beneath the Property.

Precluded activities include performing soil borings for purposes other than geotechnical investigation, obtaining soil, sediment, groundwater and surface water samples, and conducting field or laboratory analyses of any soil, sediment, groundwater or surface water samples obtained from CSXT property to identify chemical composition or environmental condition. If any type of environmental investigation is desired, a separate right of entry agreement issued through CSXT's Environmental Department must be secured.

10. CLAIMS: Licensee shall, or shall require Agents, to promptly notify the Division Engineer of any loss, damage, injury or death arising out of or in connection with the Project.

11. REMEDIATION: It is understood and agreed that, upon completion of the Project, the Property shall be left in a condition satisfactory to Division Engineer or his or her duly authorized representative.

12. SAFETY:

12.1 All personnel entering the Property must comply with CSXT safety rules and requirements to include, without exception, the wearing of hard hats and approved safety shoes and safety glasses with side shields. Anyone not in compliance with these rules and regulations will be asked to leave the Property.

12.2 Before performing any work authorized by this Agreement, Licensee, at its sole cost and expense, shall obtain all necessary permit(s) (including but not limited to zoning, building, construction, health, safety or environmental matters), letter(s) or certificate(s) of approval. Licensee expressly agrees and warrants that it shall conform and limit its activities to the terms of such permit(s), approval(s) and authorization(s), and shall comply with all applicable ordinances, rules, regulations, requirements and laws of any governmental authority (state, federal or local) having jurisdiction over Licensee's activities, including the location, contact, excavation and protection regulations of the Occupational Safety and Health Act (OSHA) (29 CFR 1926.651(b), et al.), and State "One Call" -"Call Before You Dig" requirements.

13. TERM: This Right-of-Entry Agreement and the permission conferred and the license granted by it does not constitute a grant of permanent easement and shall terminate upon completion of the Project or at midnight, _____, whichever occurs first, unless extended in writing by CSXT. In the event Licensee fails to comply with terms and provisions of this Agreement, Licensee agrees to pay and agrees that CSXT shall be entitled to recover costs and expenses incurred by CSXT, including legal fees and expenses, to enforce the terms of this Agreement.

14. SEVERABILITY: The parties agree that if any part, term or provision of the Agreement is held to be illegal, unenforceable or in conflict with any applicable federal, state, or local law or regulation, such part, term or provision shall be severable, with the remainder of the Agreement remaining valid and enforceable. If any provision or any part of a provision of the Agreement shall be finally determined to be superseded, invalid, illegal, or otherwise unenforceable pursuant to any applicable law, ordinance, rule or regulation, such determination shall not impair or otherwise affect the validity, legality, or enforceability of the remaining provision or parts of the provision of the Agreement, which shall remain in full force and effect as if the unenforceable provision or part were deleted.

15. ENTIRE AGREEMENT: This Agreement embodies the entire understanding of the parties, may not be waived or modified except in a writing signed by authorized representatives of both parties, and supersedes all prior or contemporaneous written or oral understandings, agreements or negotiations regarding its subject matter.

16. NOTICES: All notices, consents and approvals required or permitted by this agreement shall be in writing and shall be deemed delivered; upon personal delivery, upon the expiration of three (3) business days following mailing by U.S. first class mail, or upon the next business day following mailing by a nationally recognized overnight carrier, to the Licensee at the address above, and to Licensor at the address shown on Page 1, or at such other addresses as either party may designate by delivery of prior notice to the other party .

17. TERMINATION: CSXT shall have the right at any time and at its sole discretion to terminate this Agreement upon notice to Licensee.

18. WAIVER: If either party fails to enforce its respective rights under this Agreement, or fails to insist upon the performance of the other party's obligations hereunder, such failure shall not be construed as a permanent waiver of any rights or obligations in this Agreement.

19. GOVERNING LAW; VENUE: This Agreement shall be governed by and construed under the laws of the State of Florida, without regard to the choice of law provisions thereof. Venue for any action arising from, or brought to enforce, this Agreement, shall vest exclusively in the state or federal courts located in Duval County, Florida, and the parties agree to submit to the personal jurisdiction of any state or federal court located in Duval County, Florida.

20. NO ASSIGNMENT: Notwithstanding anything to the contrary contained in this Agreement, Licensee shall not permit Agents to enter the Property without first requiring Agents to agree in writing to comply with all of the terms of this Agreement. Notwithstanding the foregoing, Licensee shall continue to be responsible for insuring that Agents comply with all of the terms and conditions of this Agreement and shall indemnify and hold CSXT harmless for any damages described in Section 2 above caused in whole or in part by such subcontractor. Assignment of this Agreement to any party other than Agents in accordance with this Section shall not be permitted except upon the prior written consent of CSXT, which consent may be granted or withheld at CSXT's sole discretion. This Agreement shall be binding upon the parties and their respective successors and assigns.

IN WITNESS WHEREOF, the parties hereto have caused this Agreement to be executed as of the day and year first above written.

Witness for CSX Transportation:

CSX TRANSPORTATION, INC.

By: _____

Name:
Title:

Witness for: (*****)

(*****):

By: _____

Print/Type Name: _____

Print/Type Title: _____

Who, by the execution hereof, affirms that he/she has the authority to do so and to bind the [*] to the terms and conditions of this Agreement.

ATTACHMENT "A" INSURANCE REQUIREMENTS

Evidence required by CSX Transportation, Inc.

You are required to furnish Insurance to protect CSX Transportation, Inc. in connection with activities to be performed on or adjacent to CSX Transportation's Right of Way.

The following summarize CSXT's specifications for proper evidence of insurance:

1. Commercial General Liability coverage at their sole cost and expense with limits of not less than \$5,000,000 in combined single limits for bodily injury and/or property damage per occurrence, and such policies shall name CSXT as an additional insured.
2. Statutory Worker's Compensation and Employers Liability Insurance with limits of not less than \$1,000,000, which insurance must contain a waiver of subrogation against CSXT and its affiliates [if permitted by state law].
3. Commercial automobile liability insurance with limits of not less than \$1,000,000 combined single limit for bodily injury and/or property damage per occurrence, and such policies shall name CSXT as an additional insured.
4. Railroad protective liability insurance with limits of not less than \$5,000,000 combined single limit for bodily injury and/or property damage per occurrence and an aggregate annual limit of \$10,000,000, which insurance shall satisfy the following additional requirements:
 - a. The Railroad Protective Liability Insurance Policy must be on the ISO/RIMA Form of Railroad Protective Insurance - Insurance Services Office (ISO) Form CG 00 35.
 - b. CSX Transportation must be the named insured on the Railroad Protective Liability Insurance Policy. The address should be listed as:

CSX Transportation, Inc.
500 Water Street - C907
Jacksonville, FL 32202
 - c. Name and Address of Licensee must be shown on the Declarations page.
 - d. A description of operations and location must appear on the Declarations page and must match the Project description.
 - e. Authorized endorsements must include the Pollution Exclusion Amendment - CG 28 31, unless using form CG 00 35 version 96 and later.
 - f. Authorized endorsements may include:
 - (i) Broad Form Nuclear Exclusion - IL 00 21
 - (ii) 30-day Advance Notice of Non-renewal or cancellation
 - (iii) Required State Cancellation Endorsement
 - (iv) Quick Reference or Index - CL/IL 240
 - g. Authorized endorsements may not include:
 - (i) A Pollution Exclusion Endorsement except CG 28 31
 - (ii) A Punitive or Exemplary Damages Exclusion
 - (iii) A "Common Policy Conditions" Endorsement
 - (iv) Any endorsement that is not named in Section 4 (e) or (f) above.
 - (v) Policies that contain any type of deductible
5. All insurance companies must be A. M. Best rated A- and Class VII or better.
6. Such additional or different insurance as CSXT may require.

II. Additional Terms

1. Licensee must submit the original Railroad Protective Liability policy, Certificates of Insurance and all notices and correspondence regarding the insurance policies to:

insurancedocuments@csx.com

2. Licensee may not begin work on the Project until it has received CSXT's written approval of the required insurance.

APPENDIX

CSX Transportation

RIGHT OF ENTRY AND INDEMNITY AGREEMENT FOR BRIDGE PAINTING (AESTHETIC)

**Public Projects Group
Jacksonville, FL**

Date Issued: September 9, 2014

Project: City, County, State – Proposed Project Description and location; DOT #123456A; Milepost xxx-123.45; Division; Subdivision; OP _____

RIGHT OF ENTRY AND INDEMNITY AGREEMENT FOR BRIDGE PAINTING (AESTHETIC)

This Agreement is made and effective as of _____, by and between CSX TRANSPORTATION, INC., a Virginia corporation, with a mailing address of 500 Water Street, Jacksonville, Florida 32202, hereinafter called “CSXT,” and the Name of Agency, a public corporation, under the laws of the State of State, with a mailing address of Street Address, PO Box, City State and ZIP, hereinafter called “AGENCY”.

WHEREAS, CSXT controls and operates a right of way and bridge located within the ***** Division, ***** Subdivision, at DOT#: 123456A MP XXX-123.45. Street Name in City, County County, State (“the Property”);

WHEREAS, AGENCY has submitted a written request to enter the Property and to clean and paint the facing of the bridge (the “Project”) as described in Exhibit A, attached and incorporated by reference; and

WHEREAS, CSXT is willing to grant AGENCY the limited right and permission to enter upon the Property for the limited purpose of performing the Project;

NOW, THEREFORE, CSXT hereby grants to AGENCY the right and permission to enter upon the Property for the purpose of performing the Project, subject to the terms and conditions set forth below:

1. TERM AND SCOPE

From the period starting from the date of execution of this Agreement, through the date that is one year from such date unless further extended by mutual agreement of the parties (the “Term”), AGENCY, through its employees, agents, contractors, subcontractors, and/or other representatives (each, a “Designee” and collectively, “Designees”), may, only once (meaning not on a repetitive basis) enter the Property and perform the Project (the “Work”). Notwithstanding the foregoing, provided that CSXT shall first have approved the specifications therefore, as set forth in Section 2 hereof, AGENCY may also engage in periodic spot painting to remove graffiti (the “Spot Painting”).

2. PROJECT

A. All plans, specifications, drawings and other documents necessary or appropriate to the design and performance of the Project, including but not limited to paint color and temporary attachment specifications (if any), shall be prepared, at AGENCY’s sole cost and expense, by AGENCY or its Designees. Such plans shall be submitted to CSXT for review and approval of CSXT at least thirty (30) days prior to starting the Work or Spot Painting. The specifications for Spot Painting must include the paint color (which must be compatible with the most recent paint applied), application method (e.g. spray, brush, etc.), and structure access/reach equipment type (e.g. ladders, man lifts, etc.). CSXT may require paint removal prior to Spot Painting for safety reasons; if so, AGENCY must also submit a paint removal method (e.g. sand-blasting, chemical removal, etc.). **No Work or Spot Painting may begin until CSXT has approved the plans and specifications.** By its review or approval of plans pursuant to this Agreement, CSXT signifies only that such plans and performance of the Work and Spot Painting in accordance with such plans satisfy CSXT’s requirements.

B. Upon receipt of the specifications, CSXT’s authorized representative will determine and inform AGENCY whether a flagman need be present and whether AGENCY need implement any special protective or safety measures. If a flagman is required, AGENCY shall notify CSXT’s authorized representative and arrange for safety protection in accordance with this Agreement.

C. The Work and Spot Painting shall be performed in accordance with good and sound practices, to the satisfaction of CSXT’s authorized representative in a manner to avoid accidents, damages, unnecessary delays to or interference with the continuous and uninterrupted use of CSXT tracks or other operations, including train, signal, telephone and communication services, or damage to CSXT’s property, or to poles, wires, and other facilities of tenants on CSXT’s property or right-of-way. Under no circumstances shall Work or Spot Painting affect the operations or safety of trains. If conditions arising from or in connection with the Project require that immediate and unusual provisions be made to protect train operation or CSXT’s property, AGENCY shall make such provision.

Project: **City, County, State** – Proposed **Project Description and location**; DOT #**123456A**; Milepost **xxx-123.45**; Division; Subdivision; OP _____

D. The Project shall be designed and the Work and Spot painting performed at no cost, expense or liability to CSXT.

3. COMMENCEMENT OF WORK; AUTHORITY OF CSXT REPRESENTATIVE

A. AGENCY shall not commence any Work on CSXT Property until AGENCY has:

1. Notified CSXT in writing of the date that it expects Work or Spot Painting to commence on the Project. Such notice must be received by CSXT at least ten (10) business days in advance of the date AGENCY proposes to begin Work or Spot Painting on the Property. The notice must refer to this Agreement by date.
2. Obtain authorization from CSXT's authorized representative to begin Work on CSXT property, such authorization to include an outline of specific conditions with which AGENCY must comply.

B. CSXT retains the paramount right to regulate all activities affecting its property and operations. CSXT's authorized representative shall have final authority in all matters affecting the safe maintenance of CSXT operations and CSXT property, and his or her approval shall be obtained by AGENCY for methods of construction to avoid interference with CSXT operations and CSXT property and all other matters contemplated by the Agreement.

4. FLAGGING / INSPECTION SERVICE

A. CSXT has sole authority to determine the need for flagging required to protect its operations and property.

B. CSXT shall have the right to assign an individual to the site of the Project to perform inspection service whenever, in the opinion of CSXT's authorized representative, such inspection may be necessary.

C. Any CSXT expenses associated with flagging and inspection service shall be calculated, estimated, and reimbursed by AGENCY in the manner described in Section 10.

D. Should CSXT's authorized representative determine that flagging is necessary, AGENCY may attempt to coordinate the timing of the Work or Spot Painting with CSXT's authorized representative so that the Project may be performed during times that flagging is already ongoing at the Property.

5. SAFETY

A. CSXT will provide AGENCY with a copy of its safety rules and requirements prior to the commencement of the Work or Spot Painting. Any AGENCY personnel or Designee entering the Property must comply with CSXT's safety rules and requirements. Anyone not in compliance with these rules and regulations will be asked to leave the Property.

B. Before performing any Work authorized by this Agreement, AGENCY, at no expense to CSXT, will obtain all necessary permit(s) (including, but not limited to, zoning, building, construction, health, safety or environmental matters), letter(s) or certificate(s) of approval. AGENCY expressly agrees and warrants that it shall conform and limit activities to the terms of such permit(s), approval(s) and authorization(s), and shall comply with all applicable ordinances, rules, regulations, requirements and laws of any governmental authority (state, federal or local) having jurisdiction over the activities in the Project, including applicable provisions of the Occupational Safety and Health Act (OSHA) (29 CFR 1926.651(b), et al.).

6. ACCESS LIMITATIONS; STORAGE OF MATERIALS

A. This Agreement does not give AGENCY the right to cross CSXT property or tracks with vehicles, equipment or in any other matter other than at an existing and open public crossing. At no time will anyone performing the Work or Spot Painting be allowed beyond the bridge abutments on CSXT's property or be allowed on top of the bridge unless accompanied by CSXT personnel.

Project: **City, County, State** – Proposed **Project Description and location**; DOT #123456A; Milepost xxx-123.45; Division; Subdivision; OP _____

B. AGENCY shall not store materials or equipment on CSXT's property or where they may potentially interfere with CSXT's operations, unless AGENCY has received prior written permission from CSXT's authorized representative.

7. ENVIRONMENTAL

A. This Agreement does not include and expressly excludes the performance of any site investigation activities designed to determine environmental conditions on, about or beneath the Property.

B. AGENCY shall comply with all federal, state and local environmental laws and regulations in its work at the Property and shall perform the Work or Spot Painting in an environmentally protective manner, and shall prevent releases and spills of any materials that could harm human health or the environment, including but not limited to, hydrocarbon products, anti-freeze, spent mechanical draining, solvents, hazardous substances and hazardous wastes as defined in the Comprehensive Environmental Response, Compensation and Liability Act and the Resource Conservation and Recovery Act, respectively ("Environmental Substances"). AGENCY, at its expense, shall assume all responsibility for the investigation and cleanup of any release or discharge of any Environmental Substance at the Property that arises from the performance of any work, presence or other activity at the Property by AGENCY or its Designees. In addition to other liability terms contained in this Agreement, AGENCY agrees to indemnify, defend and hold harmless CSXT and CSXT's Affiliates from and against all environmental costs and expenses, including without limitation, all environmental analysis and cleanup expenses, fines and claims, or penalties arising from any work, presence or activity of the AGENCY or its Designees at the Property.

8. REMEDIATION AND CLEAN-UP

AGENCY, upon completion of the Work or Spot Painting, shall (i) remove from the Property any equipment, surplus materials, or rubbish belonging to AGENCY or AGENCY's Designee; and (ii) leave CSXT Property to its original condition, satisfactory to CSXT's authorized representative.

9. INSURANCE AND WAIVERS

AGENCY shall (i) acquire or require AGENCY's Designee to purchase and maintain insurance in compliance with CSXT's insurance requirements attached to this Agreement as Exhibit B; (ii) require any individual not employed by AGENCY to execute the Waiver and Release Form attached hereto as Exhibit C; and (iii) require any Designee to execute the Acceptance by AGENCY Designee Form attached hereto as Exhibit D prior to entering CSXT property and/or commencing any Work or Spot Painting. Neither AGENCY nor AGENCY's Designee shall commence the Work or Spot Painting until such insurance policy or policies and forms have been submitted to and approved by CSXT's Risk Management Department.

10. CSXT'S COSTS AND EXPENSES; REIMBURSEMENT PROCEDURES

A. Reimbursable Expenses. AGENCY shall reimburse CSXT or shall cause AGENCY's Designee to reimburse CSXT for all costs and expenses incurred by CSXT in connection with the Project, Work or Spot Painting (the "Reimbursable Expenses").

B. Estimate. CSXT has estimated the total Reimbursable Expenses as shown on Exhibit E (the "Estimate", as amended or revised). In the event CSXT anticipates that actual Reimbursable Expenses may exceed such Estimate, it shall provide AGENCY with the revised Estimate of the total Reimbursable Expenses.

C. Payment Terms. Upon execution and delivery of this Agreement by AGENCY, AGENCY will deposit with CSXT a sum equal to the estimated Reimbursable Expenses, as shown by the Estimate. Following completion of the Project, CSXT shall submit to AGENCY a final invoice that reconciles the total costs incurred by CSXT against the total payments received from AGENCY. AGENCY shall pay to CSXT the amount by which expenses exceed total payments as shown by the final invoice, within thirty (30) days following delivery of such invoice to AGENCY. In the event that the payments received by CSXT from AGENCY exceed the estimated expenses, CSXT shall remit such excess to AGENCY.

11. INDEMNIFICATION.

A. As a material inducement for entering into this Agreement, and without which CSXT would not enter into the same, AGENCY covenants and agrees that to the extent permitted by law, AGENCY shall indemnify, defend, and hold CSXT and its affiliates harmless from and against all claims, demands, payments, suits, actions, judgments, settlements, and damages of every nature, degree, and kind (including direct, indirect, consequential, incidental, and punitive damages), for any injury to or death to any person(s) (including, but not limited to the employees of CSXT, its affiliates, AGENCY or its Designees), for the loss of or damage to any property whatsoever (including but not limited to property owned by or in the care, custody, or control of CSXT, its affiliates, AGENCY or its Designees), arising or resulting from the performance of this Agreement by AGENCY or any other person performing any work or service on the AGENCY's behalf on or about the Property. The foregoing indemnification obligation shall not be limited to the insurance coverage required by this Agreement, except to the extent required by law or otherwise expressly provided by this Agreement.

B. **Compliance with Laws.** AGENCY shall comply, and shall require its Designees to comply, with any federal, state, or local laws, statutes, codes, ordinances, rules, and regulations applicable to its construction and maintenance of the Project. AGENCY's Designees shall indemnify, defend, and hold CSXT and its affiliates harmless with respect to any fines, penalties, liabilities, or other consequences arising from breaches of this Section.

C. **"CSXT Affiliates"**. For the purpose of this Agreement, CSXT's affiliates include CSX Corporation and all entities, directly or indirectly, owned or controlled by or under common control of CSXT or CSX Corporation and their respective officers, directors, employees and agents.

D. **Survival.** The provisions of this Section shall survive the termination or expiration of this Agreement.

12. CLAIMS

AGENCY shall promptly notify the CSXT's authorized representative of any loss, damage, or injury arising out of or in connection with the Work or Spot Painting. AGENCY shall not create, permit or suffer any mechanic's or materialmen's liens of any kind or nature to be created or enforced against any property of CSXT for any such Work or Spot Painting performed.

13. MAINTENANCE

A. **By AGENCY.** Upon completion of the Project, AGENCY, or its Designee, shall be solely responsible for maintaining the aesthetic appearance of the Project, including taking any actions deemed necessary by CSXT, in its sole discretion, to address any damage or disfiguration due to vandalism or graffiti by Spot Painting, in accordance with Section 1. In the event AGENCY or its Designee fails to maintain the aesthetic appearance of the Project in a reasonable condition, as determined by CSXT in its sole discretion, CSXT, after due notice to AGENCY, may [(i) require AGENCY to remove or paint over the mural, (ii) at AGENCY Designee's sole cost and expense arrange for the mural to be removed or painted over, or (iii)] take such action as it deems appropriate to restore the railroad bridge to a condition acceptable to CSXT. For purposes of this Section, "due notice" shall mean thirty (30) days' notice unless CSXT, in its sole discretion, determines that an emergency condition exists, in which case, AGENCY or its Designee shall take immediate action.

B. **By CSXT.** CSXT shall not in any manner be restricted from (i) maintaining, repairing, replacing or renewing its tracks, all parts of the railroad bridge supports, signal and communication systems or any other rail facilities or its property as it deems appropriate or (ii) performing any actions required to reasonably support rail operations. Neither shall CSXT in any manner be responsible for any damage or disfiguration caused to the Project due to such work, actions, or railroad operations, nor shall CSXT be responsible for the aesthetic appearance of the mural or the area of the railroad bridge supports upon which the Project is painted, so long as AGENCY remains responsible for the maintenance of the Project.

C. **Alterations.** AGENCY shall not undertake any alteration, modification or expansion of the Project, without the prior approval of CSXT, which may be withheld for any reason, and the execution of such agreements as CSXT may require.

14. INDEPENDENT CONTRACTOR

The parties agree that neither AGENCY nor the AGENCY Designee shall be deemed either agents or independent contractors of CSXT. Except as otherwise provided by this Agreement, CSXT shall exercise no control whatsoever over the employment, discharge, compensation of, or services rendered by AGENCY or AGENCY’s Representative, or the construction practices, procedures, and professional judgment employed by AGENCY or AGENCY’s Representative to complete the Project. Notwithstanding the foregoing, this Section shall in no way affect the absolute authority of CSXT to prohibit AGENCY or AGENCY’s Representative or anyone from entering CSXT’s property, or to require the removal of any person from its property, if it determines, in its sole discretion, that such person is not acting in a safe manner or that actual or potential hazards in, on or about the Property exist.

15. INTERPRETATION

AGENCY and CSXT each acknowledge that the terms, covenants, conditions, and provisions of this Agreement have been negotiated between and jointly authored by the parties hereto, and in consequence of this joint authorship, the parties agree that no term, covenant, condition or provision hereunder shall be construed more strictly against one party or the other hereto.

16. SEVERABILITY

The parties agree that if any part, term or provision of the Agreement is held to be illegal, unenforceable or in conflict with any applicable federal, state, or local law or regulation, such part, term or provision shall be severable, with the remainder of the Agreement remaining valid and enforceable. If any provision or any part of a provision of the Agreement shall be finally determined to be superseded, invalid, illegal, or otherwise unenforceable pursuant to any applicable law, ordinance, rule or regulation, such determination shall not impair or otherwise affect the validity, legality, or enforceability of the remaining provision or parts of the provision of the Agreement, which shall remain in full force and effect as if the unenforceable provision or part were deleted.

17. ENTIRE AGREEMENT

This Agreement embodies the entire understanding of the parties, may not be waived or modified except in a writing signed by authorized representatives of all parties, and supersedes all prior or contemporaneous written or oral understandings, agreements or negotiations regarding its subject matter. No modification or alteration of the terms hereof shall be binding unless such modification or alteration is in writing and executed by the parties.

18. NOTICES

All notices, consents and approvals required or permitted by this agreement shall be in writing and shall be deemed delivered; upon personal delivery, upon the expiration of three (3) business days following mailing by U.S. first class mail, or upon the next business day following mailing by a nationally recognized overnight carrier, to the parties at the addresses set forth below, or such other addresses as either party may designate by delivery of prior notice to the other party.

TO CSXT: CSX Transportation, Inc.
500 Water Street, J301
Jacksonville, Florida 32202
Attention – Director Project Management, Public Projects

TO AGENCY: Name
Title
Agency
Street Address
City, State ZIP

19. TERMINATION

CSXT and AGENCY shall have the right to terminate this Agreement upon notice for any reason.

Project: City, County, State – Proposed Project Description and location; DOT #123456A; Milepost xxx-123.45; Division; Subdivision; OP _____

Termination of this Agreement or Work on the Project, for any reason, shall not diminish or reduce AGENCY’s obligation to pay CSXT for Reimbursable Expenses incurred in accordance with this Agreement. In the event of the termination of this Agreement or the Work for any reason, CSXT’s only remaining obligation to AGENCY shall be to refund to AGENCY payments made to CSXT in excess of Reimbursable Expenses in accordance with Section 10.

20. WAIVER

If any party fails to enforce its respective rights under this Agreement, or fails to insist upon the performance of the other party’s obligations hereunder, such failure shall in no way be construed as a permanent waiver of any rights or obligations in this Agreement, nor in any way to affect the validity of this Agreement or any part hereof or the right of either party to thereafter enforce each and every such provision and to exercise any such right or option. No waiver of any breach of this Agreement shall be held to be a waiver of any other or subsequent breach.

21. GOVERNING LAW; VENUE

This Agreement shall be governed by and construed under the laws of the State of Florida, without regard to the choice of law provisions thereof. Venue for any action arising from, or brought to enforce, this Agreement, shall vest exclusively in the state or federal courts located in Duval County, Florida, and the parties agree to submit to the personal jurisdiction of any state or federal court located in Duval County, Florida.

22. ASSIGNMENT

This Agreement shall be binding upon the parties hereto and upon all persons successor in interest to said parties. This Agreement shall not be assignable by AGENCY without the express written consent of CSXT.

[SIGNATURE PAGE FOLLOWS]

Project: City, County, State – Proposed Project Description and location; DOT #123456A; Milepost xxx-123.45; Division; Subdivision; OP _____

IN WITNESS WHEREOF, the parties have caused this Agreement to be executed as of the day and year first above written.

Agency

CSX TRANSPORTATION, INC.

Name / Title

Date: _____

Name:
Title:

Date: _____

APPROVED AS TO FORM AND LEGALITY:

AGENCY Attorney

Date: _____

Project: City, County, State – Proposed Project Description and location; DOT #123456A; Milepost xxx-123.45; Division; Subdivision; OP _____

EXHIBIT A
PROJECT PLANS AND SPECIFICATIONS

EXHIBIT B INSURANCE REQUIREMENTS

I. Insurance Policies:

Agency and its Designee, if and to the extent that either is performing work on or about CSXT's property, shall procure and maintain the following insurance policies:

1. Commercial General Liability (CGL) coverage at their sole cost and expense with limits of not less than \$5,000,000 in combined single limits for bodily injury and/or property damage per occurrence, and such policies shall name CSXT as an additional insured.
2. Statutory Worker's Compensation and Employers Liability Insurance with limits of not less than \$1,000,000, which insurance must contain a waiver of subrogation against CSXT and its affiliates [if permitted by state law].
3. Commercial Automobile Liability insurance with limits of not less than \$1,000,000 combined single limit for bodily injury and/or property damage per occurrence, and such policies shall name CSXT as an additional insured.
4. Railroad Protective Liability (RPL) insurance with limits of not less than \$5,000,000 combined single limit for bodily injury and/or property damage per occurrence and an aggregate annual limit of \$10,000,000, which insurance shall satisfy the following additional requirements:
 - a. The Railroad Protective Liability Insurance Policy must be on the ISO/RIMA Form of Railroad Protective Insurance - Insurance Services Office (ISO) Form CG 00 35.
 - b. CSX Transportation must be the named insured on the Railroad Protective Liability Insurance Policy. The named insured's address should be listed as:

CSX Transportation, Inc.
500 Water Street, C-907
Jacksonville, FL 32202
 - c. The Name and Address of the Designee and of the Project Sponsor/Involved Governmental Agency must be shown on the Declarations page.
 - d. A description of operations and location must appear on the Declarations page and must match the Project description.
 - e. Terrorism Risk Insurance Act (TRIA) coverage must be included.
 - f. Authorized endorsements must include:
 - (i) Pollution Exclusion Amendment - CG 28 31, unless using form CG 00 35 version 96 and later
 - g. Authorized endorsements may include:
 - (i) Broad Form Nuclear Exclusion - IL 00 21
 - (ii) Notice of Non-renewal or Cancellation
 - (iii) Required State Cancellation Endorsement
 - (iv) Quick Reference or Index - CL/IL 240
 - h. Authorized endorsements may not include:
 - (i) A Pollution Exclusion Endorsement except CG 28 31
 - (ii) An Endorsement that excludes TRIA coverage
 - (iii) An Endorsement that limits or excludes Professional Liability coverage

Project: City, County, State – Proposed Project Description and location; DOT #123456A; Milepost xxx-123.45; Division; Subdivision; OP _____

- (iv) A Non-Cumulation of Liability or Pyramiding of Limits Endorsement
- (v) A Known Injury Endorsement
- (vi) A Sole Agent Endorsement
- (vii) A Punitive or Exemplary Damages Exclusion
- (viii) A “Common Policy Conditions” Endorsement
- (ix) Policies that contain any type of deductible
- (x) Any endorsement that is not named in Section 4 (f) or (g) above that CSXT deems unacceptable

5. All insurance companies must be A. M. Best rated A- and Class VII or better.

6. Such additional or different insurance as CSXT may require.

II. Additional Terms

1. Contractor must submit the complete Railroad Protective Liability policy, Certificates of Insurance and all notices and correspondence regarding the insurance policies in an electronic format to:

insurancedocuments@csx.com

2. Neither Agency nor its Designee may begin work on or about CSXT property until written approval of the required insurance has been received from CSXT or CSXT's Insurance Compliance vendor, Ebix.

III. Provision of Required Insurance through CSXT's RPL Policy.

Notwithstanding the foregoing, and in order to fully satisfy the provisions of the RPL (but not CGL) insurance requirements herein, Agency or Agency's Designee may pay CSXT, at CSXT's current rate at time of request, the cost of adding this Project to CSXT's RPL Policy for the duration of the Project. This coverage is offered at CSXT's discretion and may not be available under all circumstances

Project: City, County, State – Proposed Project Description and location; DOT #123456A; Milepost xxx-123.45; Division; Subdivision; OP _____

EXHIBIT C

WAIVER AND RELEASE FORM

TEMPORARY LICENSE AGREEMENT

_____ shall indemnify and hold CSX Transportation, Inc. ("CSXT"), the owner or holder in interest of the tract of real property known as the CSX Transportation right of way under the _____, (the "Property"), harmless from all claims, damages, demands, causes of action, suits, expenses (including attorney's fees and costs), judgments and interest whatsoever arising from a project to clean up and paint the bridge supports on the Property.

Signature: _____

Date: _____

Note: AGENCY must require any member, volunteer or other person not employed by AGENCY to execute this Waiver and Release Form, Exhibit C, prior to entering CSXT property and/or commencing any work on the Project. A copy of all Waiver and Release Forms obtained from any member, volunteer or other person not employed by AGENCY must be sent to:

Jonathan McArthur
Risk Manager – Planning & Analysis
CSX Transportation
500 Water Street C-907
Jacksonville, FL 32202
Phone: 904-359-3394
Fax: 904-306-5325

Project: City, County, State – Proposed Project Description and location; DOT #123456A; Milepost xxx-123.45; Division; Subdivision; OP _____

EXHIBIT D

ACCEPTANCE BY AGENCY DESIGNEE

To and for the benefit of CSX Transportation, Inc. ("CSXT") and to induce CSXT to permit the AGENCY Designee on or about CSXT's property for the purposes of performing Work or Spot Painting in accordance with the Agreement dated _____, 20____, between AGENCY and CSXT, AGENCY Designee hereby agrees to abide by and perform all applicable terms of the Agreement, including, but not limited to Exhibit B and Exhibit C to the Agreement, and Sections 2, 3, 7, 8, 11, and 13 of the Agreement. Any notices required to be given to AGENCY Designee shall be in writing and delivered to the person identified below.

AGENCY Designee

By: _____

Print Name: _____

Title: _____

Date: _____

Notices shall be delivered to:

[name and address]

Project: City, County, State – Proposed Project Description and location; DOT #123456A; Milepost xxx-123.45; Division; Subdivision; OP _____

EXHIBIT E

ESTIMATE OF REIMBURSABLE EXPENSES

Attached

APPENDIX

CSX Transportation

CSXT SPECIAL PROVISIONS

Public Projects Group
Jacksonville, FL
Date Issued: May 9, 2011

CSXT SPECIAL PROVISIONS

AUTHORITY OF CSXT ENGINEER

The CSXT Representative shall have final authority in all matters affecting the safe maintenance of CSXT operations and CSXT property, and his or her approval shall be obtained by the Agency or its Contractor for methods of construction to avoid interference with CSXT operations and CSXT property and all other matters contemplated by the Agreement and these Special Provisions.

II. INTERFERENCE WITH CSXT OPERATIONS

A. Agency or its Contractor shall arrange and conduct its work so that there will be no interference with CSXT operations, including train, signal, telephone and telegraphic services, or damage to CSXT's property, or to poles, wires, and other facilities of tenants on CSXT's Property or right-of-way. Agency or its Contractor shall store materials so as to prevent trespassers from causing damage to trains, or CSXT Property. Whenever Work is likely to affect the operations or safety of trains, the method of doing such Work shall first be submitted to the CSXT Representative for approval, but such approval shall not relieve Agency or its Contractor from liability in connection with such Work.

B. If conditions arising from or in connection with the Project require that immediate and unusual provisions be made to protect train operation or CSXT's property, Agency or its Contractor shall make such provision. If the CSXT Representative determines that such provision is insufficient, CSXT may, at the expense of Agency or its Contractor, require or provide such provision as may be deemed necessary, or cause the Work to cease immediately.

III. NOTICE OF STARTING WORK. Agency or its Contractor shall not commence any work on CSXT Property or rights of-way until it has complied with the following conditions:

A. Notify CSXT in writing of the date that it intends to commence Work on the Project. Such notice must be received by CSXT at least ten business days in advance of the date Agency or its Contractor proposes to begin Work on CSXT property. The notice must refer to this Agreement by date. If flagging service is required, such notice shall be submitted at least thirty (30) business days in advance of the date scheduled to commence the Work.

B. Obtain authorization from the CSXT Representative to begin Work on CSXT property, such authorization to include an outline of specific conditions with which it must comply.

C. Obtain from CSXT the names, addresses and telephone numbers of CSXT's personnel who must receive notice under provisions in the Agreement. Where more than one individual is designated, the area of responsibility of each shall be specified.

IV. WORK FOR THE BENEFIT OF THE CONTRACTOR

A. No temporary or permanent changes to wire lines or other facilities (other than third party fiber optic cable transmission systems) on CSXT property that are considered necessary to the Work are anticipated or shown on the Plans. If any such changes are, or become, necessary in the opinion of CSXT or Agency, such changes will be covered by appropriate revisions to the Plans and by preparation of a force account estimate. Such force account estimate may be initiated by either CSXT or Agency, but must be approved by both CSXT and Agency. Agency or Contractor shall be responsible for arranging for the relocation of the third party fiber optic cable transmission systems, at no cost or expense to CSXT.

B. Should Agency or Contractor desire any changes in addition to the above, then it shall make separate arrangements with CSXT for such changes to be accomplished at the Agency or Contractor's expense.

V. HAUL ACROSS RAILROAD

A. If Agency or Contractor desires access across CSXT property or tracks at other than an existing and open public road crossing in or incident to construction of the Project, the Agency or Contractor must first obtain the permission of CSXT and shall execute a license agreement or right of entry satisfactory to CSXT, wherein Agency or Contractor agrees to bear all costs and liabilities related to such access.

B. Agency and Contractor shall not cross CSXT's property and tracks with vehicles or equipment of any kind or character, except at such crossing or crossings as may be permitted pursuant to this section.

VI. COOPERATION AND DELAYS

A. Agency or Contractor shall arrange a schedule with CSXT for accomplishing stage construction involving work by CSXT. In arranging its schedule, Agency or Contractor shall ascertain, from CSXT, the lead time required for assembling crews and materials and shall make due allowance therefor

B. Agency or Contractor may not charge any costs or submit any claims against CSXT for hindrance or delay caused by railroad traffic; work done by CSXT or other delay incident to or necessary for safe maintenance of railroad traffic; or for any delays due to compliance with these Special Provisions.

C. Agency and Contractor shall cooperate with others participating in the construction of the Project to the end that all work may be carried on to the best advantage.

D. Agency and Contractor understand and agree that CSXT does not assume any responsibility for work performed by others in connection the Project. Agency and Contractor further understand and agree that they shall have no claim whatsoever against CSXT for any inconvenience, delay or additional cost incurred by Agency or Contractor on account of operations by others.

VII. STORAGE OF MATERIALS AND EQUIPMENT

Agency and Contractor shall not store their materials or equipment on CSXT's property or where they may potentially interfere with CSXT's operations, unless Agency or Contractor has received CSXT Representative's prior written permission. Agency and Contractor understand and agree that CSXT will not be liable for any damage to such materials and equipment from any cause and that CSXT may move, or require Agency or Contractor to move, such material and equipment at Agency's or Contractor's sole expense. To minimize the possibility of damage to the railroad tracks resulting from the unauthorized use of equipment, all grading or other construction equipment that is left parked near the tracks unattended by watchmen shall be immobilized to the extent feasible so that it cannot be moved by unauthorized persons.

VIII. CONSTRUCTION PROCEDURES

A. General

1. Construction work on CSXT property shall be subject to CSXT's inspection and approval.
2. Construction work on CSXT property shall be in accord with CSXT's written outline of specific conditions and with these Special Provisions.
3. Contractor shall observe the terms and rules of the CSXT Safe Way manual, which Agency and Contractor shall be required to obtain from CSXT, and in accord with any other instructions furnished by CSXT or CSXT's Representative.

B. Blasting

1. Agency or Contractor shall obtain CSXT Representative's and Agency Representative's prior written approval for use of explosives on or adjacent to CSXT property. If permission for use of explosives is granted, Agency or Contractor must comply with the following:
 - a. Blasting shall be done with light charges under the direct supervision of a responsible officer or employee of Agency or Contractor.
 - b. Electric detonating fuses shall not be used because of the possibility of premature explosions resulting from operation of two-way train radios.
 - c. No blasting shall be done without the presence of an authorized representative of CSXT. At least 30 days' advance notice to CSXT Representative is required to arrange for the presence of an authorized CSXT representative and any flagging that CSXT may require.

d. Agency or Contractor must have at the Project site adequate equipment, labor and materials, and allow sufficient time, to (i) clean up (at Agency's expense) debris resulting from the blasting without any delay to trains; and (ii) correct (at Agency's expense) any track misalignment or other damage to CSXT's property resulting from the blasting, as directed by CSXT Representative, without delay to trains. If Agency's or Contractor's actions result in delay of any trains, including Amtrak passenger trains, Agency shall bear the entire cost thereof.

e. Agency and Contractor shall not store explosives on CSXT property.

2. CSXT Representative will:

a. Determine the approximate location of trains and advise Agency or Contractor of the approximate amount of time available for the blasting operation and clean-up.

b. Have the authority to order discontinuance of blasting if, in his or her opinion, blasting is too hazardous or is not in accord with these Special Provisions.

IX. MAINTENANCE OF DITCHES ADJACENT TO CSXT TRACKS

Agency or Contractor shall maintain all ditches and drainage structures free of silt or other obstructions that may result from their operations. Agency or Contractor shall provide erosion control measures during construction and use methods that accord with applicable state standard specifications for road and bridge construction, including either (1) silt fence; (2) hay or straw barrier; (3) berm or temporary ditches; (4) sediment basin; (5) aggregate checks; and (6) channel lining. All such maintenance and repair of damages due to Agency's or Contractor's operations shall be performed at Agency's expense.

X. FLAGGING / INSPECTION SERVICE

A. CSXT has sole authority to determine the need for flagging required to protect its operations and property. In general, flagging protection will be required whenever Agency or Contractor or their equipment are, or are likely to be, working within fifty (50) feet of live track or other track clearances specified by CSXT, or over tracks.

B. Agency shall reimburse CSXT directly for all costs of flagging that is required on account of construction within CSXT property shown in the Plans, or that is covered by an approved plan revision, supplemental agreement or change order.

C. Agency or Contractor shall give a minimum of 30 days' advance notice to CSXT Representative for anticipated need for flagging service. No work shall be undertaken until the flag person(s) is/are at the job site. If it is necessary for CSXT to advertise a flagging job for bid, it may take up to 90-days to obtain this service, and CSXT shall not be liable for the cost of delays attributable to obtaining such service.

D. CSXT shall have the right to assign an individual to the site of the Project to perform inspection service whenever, in the opinion of CSXT Representative, such inspection may be necessary. Agency shall reimburse CSXT for the costs incurred by CSXT for such inspection service. Inspection service shall not relieve Agency or Contractor from liability for its Work.

E. CSXT shall render invoices for, and Agency shall pay for, the actual pay rate of the flagpersons and inspectors used, plus standard additives, whether that amount is above or below the rate provided in the Estimate. If the rate of pay that is to be used for inspector or flagging service is changed before the work is started or during the progress of the work, whether by law or agreement between CSXT and its employees, or if the tax rates on labor are changed, bills will be rendered by CSXT and paid by Agency using the new rates. Agency and Contractor shall perform their operations that require flagging protection or inspection service in such a manner and sequence that the cost of such will be as economical as possible.

XI. UTILITY FACILITIES ON CSXT PROPERTY

Agency shall arrange, upon approval from CSXT, to have any utility facilities on or over CSXT Property changed as may be necessary to provide clearances for the proposed trackage.

XII. CLEAN-UP

Agency or Contractor, upon completion of the Project, shall remove from CSXT's Property any temporary grade crossings, any temporary erosion control measures used to control drainage, all machinery, equipment, surplus materials, falsework, rubbish, or temporary buildings belonging to Agency or Contractor. Agency or Contractor, upon completion of the Project, shall leave CSXT Property in neat condition, satisfactory to CSXT Representative.

XIII. FAILURE TO COMPLY

If Agency or Contractor violate or fail to comply with any of the requirements of these Special Provisions, (a) CSXT may require Agency and/or Contractor to vacate CSXT Property; and (b) CSXT may withhold monies due Agency and/or Contractor; (c) CSXT may require Agency to withhold monies due Contractor; and (d) CSXT may cure such failure and the Agency shall reimburse CSXT for the cost of curing such failure.

APPENDIX

CSX Transportation

CRITERIA FOR OVERHEAD BRIDGES

**Office of Director Fixed Plant Engineering
Jacksonville, FL**

Date Issued: September 14, 2007

CRITERIA FOR OVERHEAD BRIDGES

CSX Transportation (CSXT) has minimum requirements for outside parties constructing, rehabilitating, or replacing bridges over CSXT's railroad tracks. These requirements are intended to provide safe and continuous passage of all train traffic during and after construction of bridges over its tracks. Part of these requirements is for the outside party to submit a detailed plan of the project as well as provide details of the construction methodology. This document provides information on the requirements by CSXT for overhead bridges.

Plans and specifications for new or reconstructed bridges over CSXT's railroad tracks or right-of-way shall meet the following requirements:

I. GENERAL REQUIREMENTS:

- A. CSXT's valuation station and the distance from the nearest milepost at the intersection of the centerline of the track and the centerline of the bridge shall be shown on the General Plan.
- B. The existing and proposed minimum horizontal and vertical clearances shall be marked clearly on the General Plan and Elevation.
- C. At least one subsurface exploration boring for each substructure unit adjacent to the track shall be furnished to CSXT's during the design submittal. Borings shall provide enough information to design shoring and foundations.
- D. Prior to construction activities, all overhead bridge projects will require the procurement of the appropriate property rights from CSX Real Property and other construction agreement(s) with CSX Transportation.
- E. All lifting equipment and connection devices shall have capacity for 150% of the actual lifting load. The factor of safety provided by the manufacturer in the lifting capacity data shall not be considered in the 150% requirement. A licensed professional engineer, familiar with lifting and rigging, in the State where the construction work is proposed must sign and seal all plans and calculations related to critical lifting on the project.

II. CLEARANCES:

- A. Horizontal Clearance: Standard horizontal clearance from centerline of the track to the face of the pier or abutment shall typically be 25'-0" or greater, but never less than 18'-0", measured perpendicular to the track. Provisions for future tracks, access roads, other CSXT facilities, and drainage may require the minimum clearance be increased or use of multi-span structures. The toe of footings shall not be closer than 11'-0" from centerline of the track to provide adequate room for sheeting.
- B. Vertical Clearance: A standard vertical clearance of 23'-0" shall be provided, measured from top of high rail to lowest point of structure in the horizontal clearance area which extends 6'-0" either side of the centerline of track.
- C. Temporary Construction clearances to be used shall be subject to approval by CSXT. Typically reductions in clearance for construction are not permitted.
- D. CSXT shall be furnished as-built drawings showing actual clearances as constructed.

III. CRASHWALLS:

AREMA Specifications, Chapter 8, Article 2.1.5 covers the requirements for crashwalls. Crashwalls are required when face of the pier is closer than 25'-0" from centerline of the track, measured perpendicular to the track, except as noted below.

Crashwalls shall meet the following requirements:

- A. Crashwalls for single column piers shall be minimum 2'-6" thick and shall extend a minimum of 6'-0" above the top of high rail for piers located between 18'-0" and 25'-0" from the centerline of the nearest track. The wall shall extend minimum 6'-0" beyond the column on each side in the direction parallel to the track.
- B. For multi-column piers, the columns shall be connected with a wall of the same thickness as the columns or 2'-6" whichever is greater. The wall shall extend a minimum of 2'-6" beyond the end of outside columns in a direction parallel to the track.

C. Reinforcing steel to adequately anchor the crashwalls to the column and footing shall be provided. For piers of heavy construction, crashwalls may be omitted. Solid piers with a minimum thickness of 2'-6" and length of 20'-0", single column piers of minimum 4'-0" X 12'-6" dimensions or any other solid pier sections with equivalent cross sections and minimum 2'-6" thickness are considered as heavy construction.

IV. DRAINAGE:

Drainage from the bridge shall be preferably collected with drain pipes and drained away from CSXT's right-of-way. When open scuppers are provided on the bridge, none shall be closer than 25'-0" of the centerline of nearest track. Flow from the scuppers shall be directed away from CSXT's drainage ditches.

Projects including stormwater systems shall be designed for a 100-year storm event as a minimum. If stormwater is drained on or to CSXT's right-of-way, calculations must be submitted to CSXT to verify the 100-year storm event is properly handled. Improvements to the adjacent drainage systems may be required at project expense, to ensure the impacted system will meet the 100-year storm event minimum condition.

During and after completion of construction, the outside party or its contractor must clear CSXT's drainage ditches of all debris to the satisfaction of CSXT's construction engineering and inspection representative.

V. PROTECTIVE FENCING:

All highway structures shall have a protective barrier fence to extend at least 8'-0" from the top of the sidewalk or driving surface adjacent to the barrier wall. The fence may be placed on top of the barrier wall. The fence shall be capable of preventing pedestrians from dropping debris onto CSXT's right-of-way, and in particular, passing trains.

Openings in the fence shall not exceed 2"x2". Fencing should also include anti-climb shields or be of a configuration to minimize the likelihood of climbing on the outside of the protective fencing. A chain link fence option is shown below:

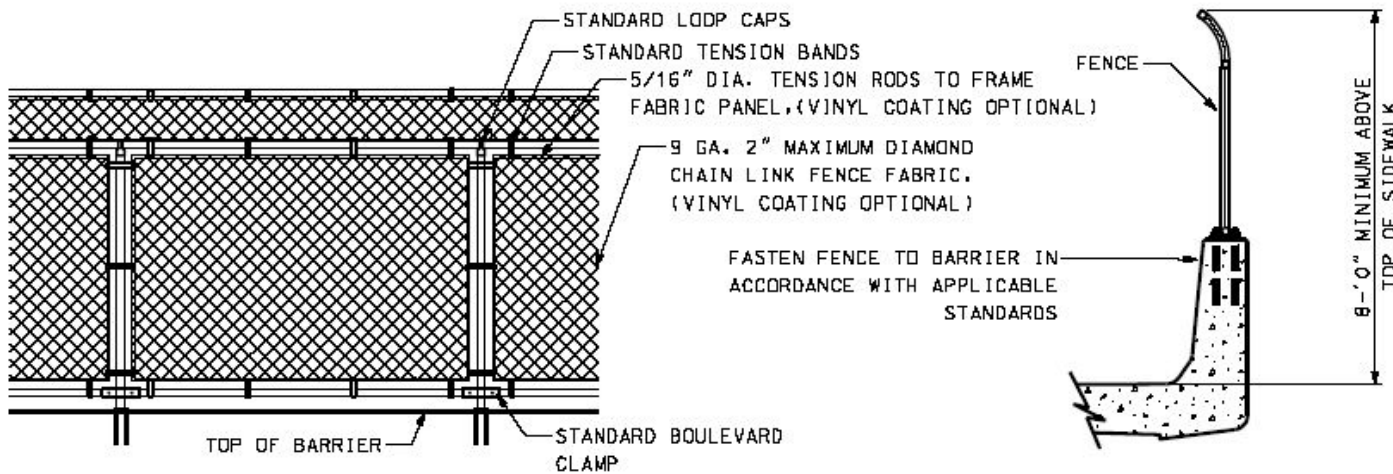

VI. STRUCTURE EXCAVATION AND SHORING:

Shoring protection shall be provided when excavating adjacent to an active track. Shoring will be provided in accordance with AREMA *Manual for Railway Engineering* Chapter 8 part 28, except as noted below.

Shoring will not be required if both the following conditions are satisfied:

1. Excavation does not encroach upon a 1 ½ horizontal: 1 vertical theoretical slope line starting 1'-6" below top of rail and at 12'-0" minimum from centerline of the track (live load influence zone).
2. Track is on level ground or in a cut section and on stable soil.

When the track is on an embankment, excavating the toe of the embankment without shoring may affect the stability of the embankment. Therefore, excavation of the embankment toe without shoring will not be permitted.

Preferred protection is the cofferdam type that completely encloses the excavation. Where dictated by conditions, partial cofferdams with open sides away from the track may be used. Cofferdams shall be constructed using steel sheet piling or steel soldier piles with timber lagging. Wales and struts shall be provided as needed. The following shall be considered when designing cofferdams:

- a. Shoring shall be designed to resist a vertical live load surcharge of 1,882 lbs. per square foot, in addition to active earth pressure. The surcharge shall be assumed to act on a continuous strip, 8'-6" wide. Lateral pressures due to surcharge shall be computed using the strip load formula shown in AREMA *Manual for Railway Engineering*, Chapter 8, Part 20.
- b. Allowable stresses in materials shall be in accordance with AREMA *Manual for Railway Engineering*, Chapter 7, 8, and 15.
- c. A construction procedure for temporary shoring shall be shown on the drawing.
- d. Safety railing shall be installed when temporary shoring is within 15'-0" of the centerline of the track.
- e. A minimum distance of 10 feet from centerline of the track to face of nearest point of shoring shall be maintained.

The contractor shall submit the following drawings and calculations for CSXT's review and approval.

1. Three (3) sets of detailed drawings of the shoring systems showing sizes of all structural members, details of connections, and distances from centerline of track to face of shoring. Drawing shall show a section showing height of shoring and track elevation in relation to bottom of excavation.
2. One set of calculations of the shoring design.

The drawings and calculations shall be prepared by a Licensed Professional Engineer in the State where shoring is to be constructed and shall bear his seal and signature. Shoring plans shall be approved by CSXT's construction engineering and inspection representative.

3. For sheeting and shoring within 18'-0" of the centerline of the track, the live load influence zone, and in slopes, the contractor shall use sheet pile. No sheet pile in slopes or within 18'-0" of the centerline of track shall be removed. Sheet piles shall be cut off 3'-0" below the finished ground line. The remaining 3'-0" shall be backfilled and compacted immediately after cut off.

VII. DEMOLITION OF EXISTING STRUCTURE:

The Contractor shall submit a detailed procedure for demolition of existing structures over or adjacent to CSXT's tracks or right-of-way. The procedure shall clearly indicate the capacity of cranes, location of cranes with respect to the tracks and calculated lifting loads (refer to Section I.E of this document). The demolition procedure must be approved by CSXT's construction engineering and inspection representative.

CSXT's tracks, signals, structures, and other facilities shall be protected from damage during demolition of existing structure or replacement of deck slab. As a minimum, both of the following methods shall be used:

A. During demolition of the deck, a protection shield shall be erected from the underside of the bridge over the track area to catch falling debris. The protection shield shall be supported from girders or beams. The deck shall be removed by cutting it in sections and lifting each section out. The protection shield shall be designed, with supporting calculations, for a minimum of 50 pounds per square foot plus the weight of the equipment, debris, personnel, and other loads to be carried.

Large pieces of deck shall not be allowed to fall on the protection shield

B. A ballast protection system consisting of geofabric or canvas shall be placed over the track structure to keep the ballast clean. The system shall extend along the track structure for a minimum of 25'-0" beyond the limits of the demolition work, or farther if required by CSXT's construction engineering and inspection representative.

C. The Contractor shall submit detailed plans, with supporting calculations, of the protection shield and ballast protection systems for approval prior to the start of demolition.

D. Blasting will not be permitted to demolish a structure over or within CSXT's right-of-way.

VIII. ERECTION PROCEDURE:

The Contractor shall submit a detailed procedure for erecting over or adjacent to CSXT's tracks or right-of-way. The procedure shall clearly indicate the capacity of cranes, location of cranes with respect to the tracks and calculated lifting loads (refer to Section. E of this document). The erection procedure must be approved by CSXT's construction engineering and inspection representative.

IX. PILE INSTALLATION:

A. For the installation of piles and sheeting for abutment foundations, pier foundations, retaining wall foundations, temporary and permanent shoring and other structures on or adjacent to CSXT's right-of-way, the contractor may be required to submit a detailed track monitoring program for CSXT's approval prior to performing any work near CSXT's right-of-way.

B. The program shall specify the survey locations, the distance between the location points, and frequency of monitoring before, during, and after construction. CSXT shall have the capability of modifying the survey locations and monitoring frequency as needed during the project.

C. If any settlement is observed, CSXT's construction engineering and inspection representative shall be immediately notified. CSXT, at its sole discretion, shall have the right to immediately require all contractor operations to be ceased, have the excavated area immediately backfilled and/or determine what corrective action is required. Any corrective action required by CSXT or performed by CSXT including the monitoring of corrective action of the contractor will be at project expense.

X. PEDESTRIAN OVERHEAD:

Pedestrian overhead bridges shall be governed by this document in its entirety with the following exceptions:

A. Pedestrian overhead bridges shall span the entire width of CSXT's right-of-way. Intermediate piers or other supports will not be permitted.

B. Pedestrian overhead bridges shall be completely enclosed with protective canopy or by other means to prevent users from dropping debris onto CSXT's right-of-way.

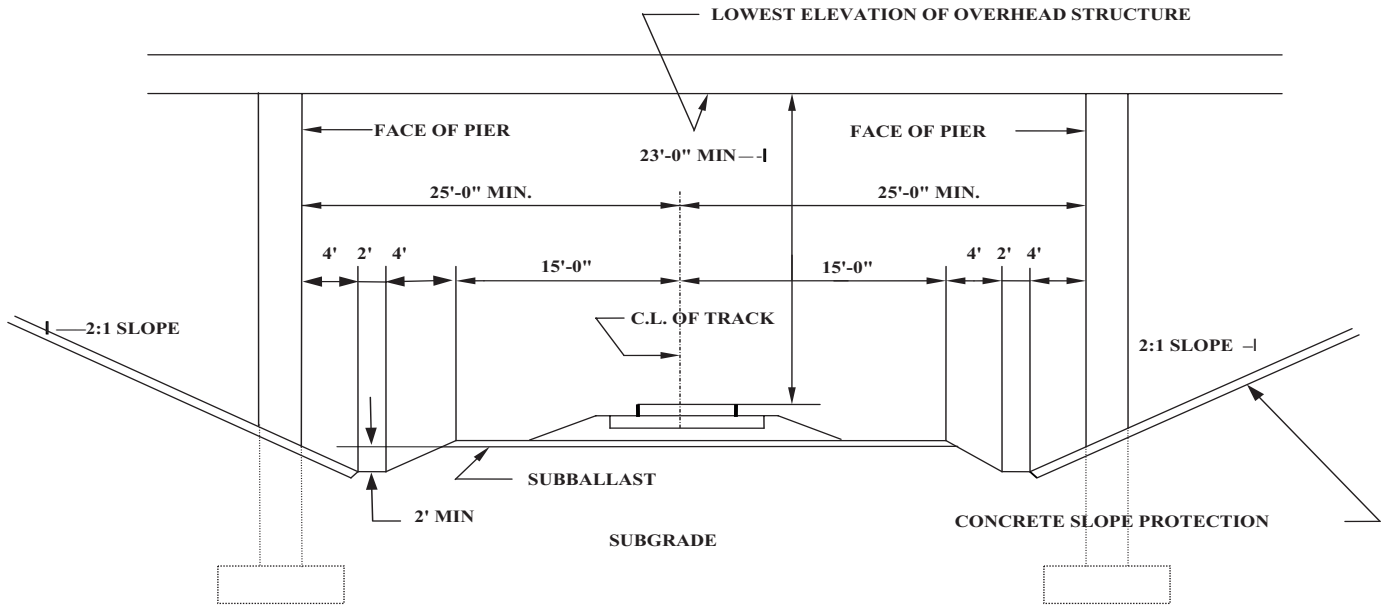

**CLEARANCES REQUIRED FOR OVERHEAD STRUCTURES
TYPICAL ROADBED SECTION WITH STANDARD DITCHES**

NOTE: FOR MULTIPLE TRACKS, STANDARD TRACK CENTERS IS 15'-0". AN ADDITIONAL 8'-0" WIDE ACCESS ROAD MAY BE REQUIRED TO PROVIDE 33'-0" MINIMUM DISTANCE FROM CENTERLINE OF TRACK TO FACE OF PIER.

CSX ENGINEERING DEPARTMENT
STANDARD CLEARANCES FOR OVERHEAD STRUCTURES

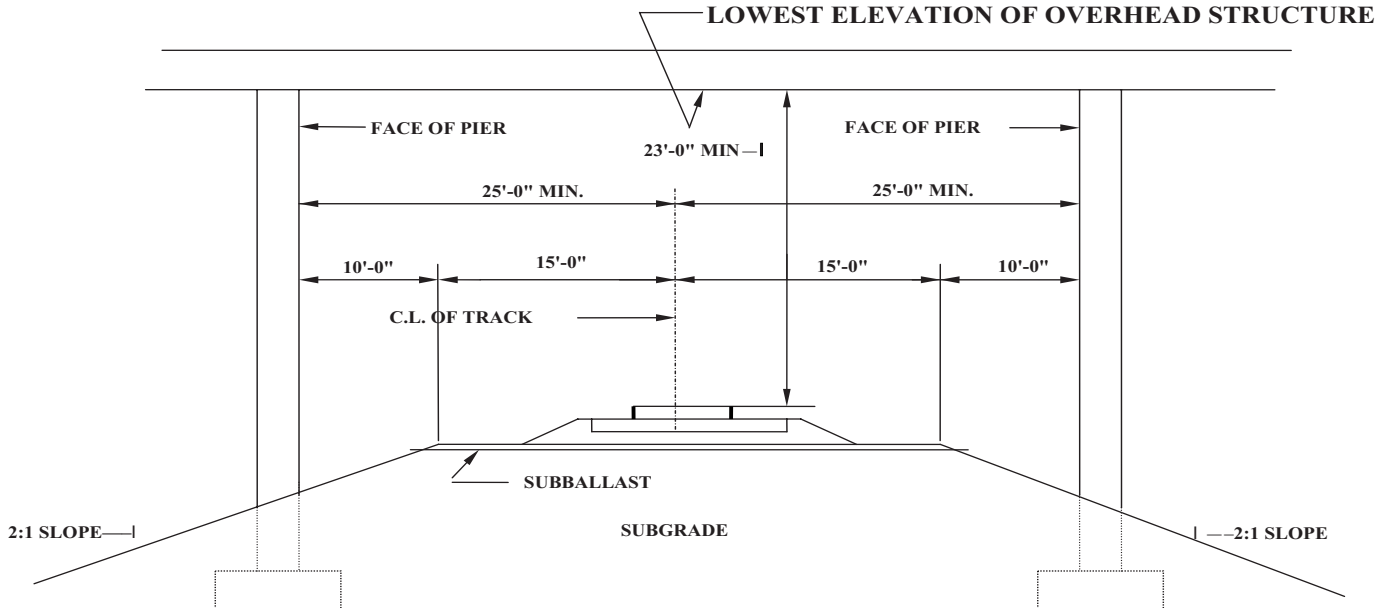

**CLEARANCES REQUIRED FOR OVERHEAD STRUCTURES
TYPICAL SECTION FOR ROADBED IN FILL**

(WHERE NO DEFINED DITCHES ARE NEEDED)

CSX ENGINEERING DEPARTMENT
STANDARD CLEARANCES FOR OVERHEAD STRUCTURES

DECK DRAINS AND SCUPPERS PROHIBITED.
ALL DRAINAGE MUST BE DIRECTED AWAY FROM CSXT PROPERTY.

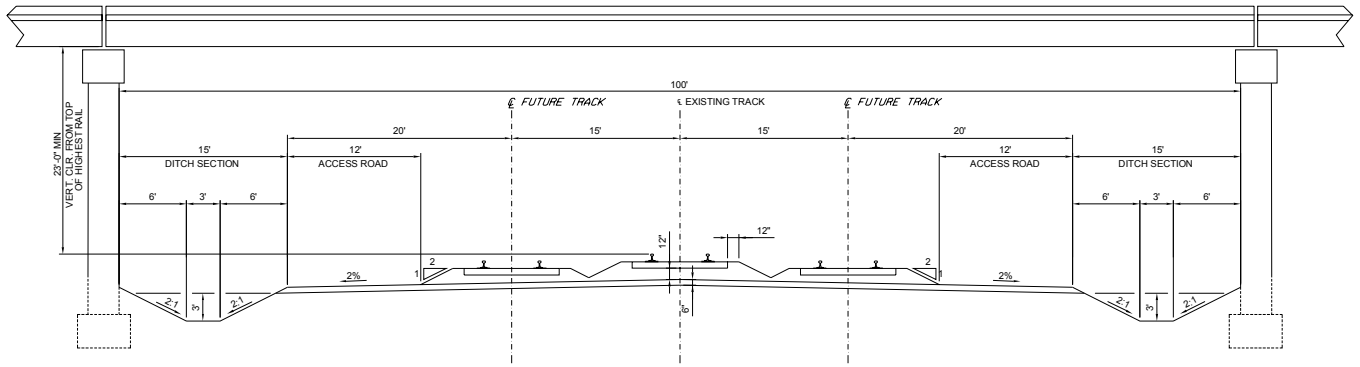

TYPICAL TRACK CROSS SECTION FOR OVERHEAD BRIDGE DESIGNS
NTS

NOTES:

1. CLEAR SPAN WIDTH SHOULD ACCOUNT FOR THE NUMBER OF EXISTING TRACKS AT SPECIFIC PROJECT SITE. EACH ADDITIONAL TRACK ADDS 15' TO THE CLEAR SPAN WIDTH CALCULATION.
2. HORIZONTAL DIMENSIONS SHOWN ARE PERPENDICULAR TO ∇ OF TRACK.
3. CRASHWALLS MAY BE REQUIRED BASED ON SITE SPECIFIC PARAMETERS.
4. ACTUAL REQUIRED HORIZONTAL CLEARANCES MAY NEED TO BE INCREASED DUE TO EXISTING ROADBED SECTION, LOCATION OF PARALLEL DITCHES, HYDROLOGICAL CONDITIONS, AND **FUTURE TRACK REQUIREMENTS**.
5. THEORETICAL TOE OF SLOPE IS BASED ON THE STANDARD ROADBED SECTION. ACTUAL TOE OF SLOPE MAY VARY DUE TO EXISTING GROUND LINE.
6. THE DITCH SECTION SHOWN IS THE MINIMUM ACCEPTABLE SECTION.
7. THE DITCH SECTION IS TO BE INCREASED AS REQUIRED BY LOCAL CONDITIONS, BASED ON HYDROLOGICAL AND HYDRAULIC STUDIES.
8. HORIZONTAL DIMENSIONS SHOWN ARE THE MINIMUM WHICH WILL ALLOW THE CONSTRUCTION OF CSXT'S STANDARD ROADBED SECTION.

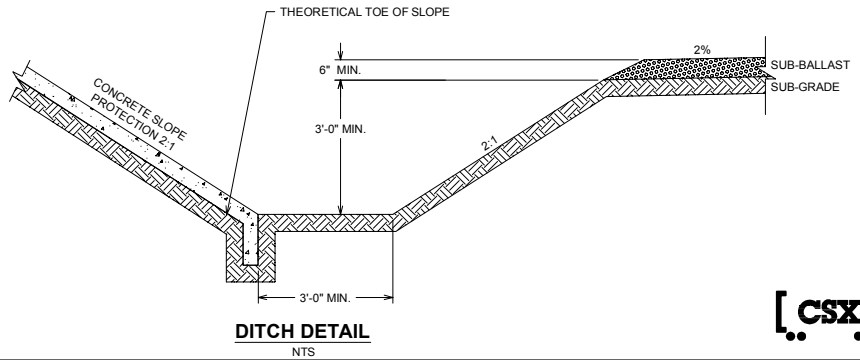

Filename: P:\020\0601 CSXT SEC 20 PROJECTS\PRELIMINARY ENGINEERING\0001 - 39903042 - CSX CONSTRUCTION CRITERIA\003\DRAWINGS\TYPICALS.DWG

APPENDIX

CSX Transportation

UNDERGRADE BRIDGE CRITERIA INCLUDING BALLAST DECKS

Public Projects Group
Jacksonville, FL
Date Issued: October 1, 1999

CRITERIA FOR BALLAST DECK RAILROAD BRIDGES

PURPOSE AND SCOPE

These criteria modify and supplement the applicable sections of the AREMA Manual of Recommended Practice in connection with the design of ballasted deck railway bridges.

I. SPECIFICATIONS:

A. Design Specifications: American Railway Engineering and Maintenance-of-Way Associations (AREMA) Manual for Railway Engineering, Current Edition.

Chapter 7.	Timber Structures
Chapter 8.	Concrete Structures and Foundations
Chapter 15.	Steel Structures
Chapter 29.	Waterproofing

B. Construction Specifications:

1. Use AREMA Manual recommendations for fabrication and erection of structural steel (Chapter 15).
2. Use AREMA Manual recommendations for Concrete Structures and foundations (Chapter 8).
3. Use AREMA Manual recommendations for dampproofing and deck waterproofing (Chapter 29).
4. CSXT Standard Specifications and Special Specifications shall be used where appropriate. Items not covered by CSXT Standard and Special Specifications should use the Standard Highway Specifications for the State where the bridge is being constructed.

II. BRIDGE LAYOUT

While preparing the initial layout of the bridge the following shall be considered:

- A. The layout of the bridge shall show the Railroad Valuation Stations at face of backwalls and at centerline of the bridge. Distance from centerline of the bridge to nearest milepost shall be shown on plan.
- B. For bridges on curves, the girders, abutments and piers shall be located with reference to chords.
- C. Provide horizontal clearance on the bridge as shown in Figure 1-1, Chapter 15 of the AREMA Manual. For curved track, increase the required clearance 1 ? inches per degree of curvature. On the inside of the curve, the required clearance shall be measured from the centerline of the track projected at right angles to the plane of the superelevation. No reduction in required clearances shall be made on outside of the curve due to superelevation. If State legal clearance requirements exceed Railroad requirements; the State legal requirements shall govern. When bridge is on tangent track but the track is curved within 80 feet of the end of bridge, the lateral clearances in Figure 1-1 shall be increased as mentioned above.
- D. Bridges over public roadways shall have walkways on both sides of the track. Preferably bridges shall be made wide enough to accommodate walkways on inside of the bridge girders.
- E. For multiple track bridges, the width of the bridge must provide proper clearances measured from centerline of each outside track. In addition adequate room shall be provided for a future 15'- 0" center to center of each track.
- F. On ballast deck bridges, timber roadway ties 7" thick, 9" wide and 8' 6" long, spaced at 1' 9" centers shall be used. Alternatively, concrete ties may be used at 2'-0" centers. Minimum ballast depth is 8" measured at the centerline of the low rail.

III. DESIGN LOADS

Railroad Bridges shall be designed for all loads specified in Chapters 8 and 15 of the AREMA Specifications. The following live loads shall be used.

Non Composite Design:	Coopers E-80 loading with full diesel impact and the Alternate Live Load.
Composite Design:	Coopers E-80 loading with full diesel impact and the Alternate Live Load.
	Coopers E-65 with full diesel impact for steel alone.

In computing dead load of structure, include the weight of an additional 6" of ballast. This allows for future track surfacing.

IV. MATERIAL REQUIREMENTS

A. STRUCTURAL STEEL:

1. Structural Steel shall be ASTM A709 Gr36, Gr50 or Gr50W. The toughness shall be T2 for non-fracture critical members or F2 for fracture critical members. Other types of steel may be used if approved by the CSX Director Structural Engineering. Thickness of flange plates shall not exceed 3 inches.
2. The engineer shall call out all fracture critical members on the plans.
3. Structural Steel shall be in accordance with CSX Transportation "Specifications for Structural Steel".
4. Structural Steel shall be painted in accordance with CSX Transportation "Specifications for Painting Structural Steel".

B. CONCRETE: Concrete shall be air entrained. Cement shall be Portland Cement, ASTM-C150, Type I or IA. Concrete shall have a minimum 28-day compressive strength of:

- 4000 psi – Substructure
- 5000 psi – Superstructure

Use of Fly Ash in concrete is not acceptable. Concrete admixtures other than air entrainment must be approved by CSX's Director Structural Engineering prior to use.

Concrete shall be in accordance with the current CSX Transportation Specifications for "Cast-In-Place Concrete."

C. REINFORCING STEEL: Deformed bars of billet steel conforming to ASTM 615, Grade 60 shall be used.

V. SUPERSTRUCTURE

A. GENERAL

1. The thickness of steel deck plate shall be as follows:

Plate Thickness	Max. Clear Distance Between Beams
?"	1'-6"
5/8"	2'-0"
?"	2'-4"

2. The steel deck plates shall be shop welded with a pair of 5/16" continuous fillet welds to each floorbeam or deck beam. Deck units shall be shop assembled with two or three beams per unit. Deck plates are not permitted to overhang the beam when these units are fabricated.
3. The closing deck plate between adjacent deck units shall be fillet welded to the beams with continuous 5/16" fillet weld at each beam. After deck plates are welded to beam, fill space between deck plates at joint with bituminous mastic.
4. For welded plate girders no more than two flange section transitions will be permitted without special permission. A full penetration groove weld shall be used for flange to web connection.
5. Intermediate stiffeners shall consist of two angles, one on each side of the web, and shall be bolted to the web. End bearing stiffeners may be plates or angles, welded or bolted.
6. Provide ?" thick, 31 ply, preformed elastomeric shock pads (MIL-C-882C specifications) between bearings and masonry.
7. Superstructures for multiple track bridges, constructed without detour tracks, shall be designed such that the superstructure can be rolled into place in segments while the temporary structure for at least one track remains intact.
8. The bottom lateral bracing system, if required by the AREMA Manual recommendations, shall be bolted to the girders.

9. Continuous spans will not be permitted.

- B. The following criteria apply to through plate girder bridges with steel deck plates and closely spaced floorbeams:
1. Floorbeam brackets (or knee braces) shall be weldments that are bolted to the top flange of the floorbeams and to vertical stiffeners on the girder. The slope of the bracket shall be 4 inches in 12 inches where possible.
 2. End floorbeams shall frame into the end stiffeners. An additional connection angle shall be provided where welded stiffener plates are used. End floorbeams and connections shall be designed such that the bridge can be jacked up by placing jacks under the end floorbeams. Jacking stiffeners shall be provided at points of jacking.
 3. Intermediate floorbeams shall frame into the girder web using double connection angles and high strength steel bolts. At brackets or at other locations where there is an intermediate stiffener, the stiffener on the inside of the girder shall be terminated 1" minimum above the top of the floorbeam.
 4. Through plate girder spans are limited to single and double track bridges only.

- C. The following criteria apply to bridges with multiple deck girders with steel deck plates.
1. Provide a welded field splice in the deck plates at or near the centerline of bearing of the girders. Provide a closing deck plate from the abutment to this field splice that is normal to the girders and normal to the long direction of the main deck plates. This will avoid splicing deck plates over the backwall.
 2. Steel fascia girders may be used in addition to the load carrying girders. The depth of fascia girders shall be 1/12 of the span length. The depth shall also be enough to place the top flange 3 inches above the top of high rail when a handrail is placed along the girder or 38 inches above the top of high rail when no handrail is used. The web of the fascia girder shall be 1/170 of the depth with ? inch minimum. The flanges shall be 12"x 1" minimum.
 3. If fascia girders are not used, girders shall be spaced such that deck plates will not overhang the flange of the outside girders by more than 2 inches and a concrete parapet wall shall be provided. The wall shall be securely anchored to the deck plate and have a minimum thickness of 12 inches at the top. The height of the wall shall be as specified for fascia girders.

- D. The following criteria apply to deck girder bridges with reinforced concrete deck slabs.
1. Minimum thickness of slabs shall be:
 - 12" for composite design
 - 8" for non composite designThe deck slab shall be wide enough to provide room for walkways. This may be accomplished by providing a full width ballast trough or ballast trough with raised concrete walkways.
 2. Epoxy coated reinforcing bars shall be used throughout the slab.
 3. The outside edge of the slab shall be not more than 1' – 6" from the centerline of the outside girder. Provide a ?" drip bead on the bottom face of slab.
 4. Provide a concrete parapet wall on each side of deck slab. Wall to have a minimum thickness of 12" at the top with reinforcing anchored into the slab. Top of wall shall be 3" above top of high rail if a handrail is provided and 38" above top of high rail without handrail.
 5. For composite design, the following minimum reinforcing shall be provided in the slab:
 - Transverse direction - #5 at 6" c. to c.
 - Longitudinal direction - #5 at 9" c. to c.

VI. DECK DRAINAGE

1. Top surface of waterproofing protection shall have a transverse slope of 1" with a crown under centerline of each track. Use an underlayment with a minimum thickness of 3 ?" of portland cement concrete with welded wire fabric or 1" bituminous mastic underlayment to provide required slope on steel decks. Underlayments shall be in accordance with the requirements of AREMA, Chapter 29, Section 2.5 Underlayment. Concrete decks shall be cast to provide desired slope. Use longitudinal half round deck drains and pans at ballast retainers and between tracks to collect discharge.

2. Top surface of waterproofing protection shall have a minimum longitudinal slope of 0.5%. When the deck is level or slopes less than 0.5%, underlayment be used to provide longitudinal slope also. Concrete decks shall be cast to provide required slope. Use longitudinal half round deck drains and pans at ballast retainers and between tracks.
3. Deck drains and bottom pans shall be 12 gage, galvanized and bituminous coated.
4. For concrete deck bridges where membrane waterproofing is not used, Ductile Iron pipe drains through the deck with Ductile Iron or stainless steel collection system may be used in lieu of the surface drainage system using half round drains.
5. For longer bridges, intermediate drains at the piers may be required. Use six-inch diameter; Schedule 40 steel pipe for these drains. All pipe, connections, hanger and brackets shall be galvanized or stainless steel. Field connections shall be made with Style 77 Victaulic coupling or equal. Each ballast drain shall have a downspout to a collector on the substructure. Provide a one-inch gap between downspouts and the collector piping.
6. Two feet of porous backfill, measured horizontally, shall be provided behind all abutments and wingwalls. Provide perforated pipe drains behind abutment at bottom to remove drainage. Half-round deck drains shall be connected by downspouts to the perforated pipe at the bottom of porous backfill. This pipe and downspouts shall be 8 inch, 16 gage corrugated metal pipe, galvanized and bituminous coated. The perforated pipe shall be connected to a non-perforated 8 inch, 16 gage corrugated metal, galvanized and bituminous-coated pipe prior to exiting from behind abutments. The non-perforated pipe shall be drained away from the bridge with a 1% minimum slope.

VII. DECK WATERPROOFING

A. GENERAL

1. All steel bridge decks shall be waterproofed using membrane waterproofing.
2. Concrete bridge decks shall be waterproofed using membrane waterproofing when the bridge is located in areas subject to frequent freeze and thaw cycles. In areas not subject to frequent freeze and thaw cycles, the deck surface may be dampproofed. Railroad's Director Structural Engineering shall have final authority as to which system will be used.
3. All deck joints between spans shall be watertight.
4. Waterproofing or dampproofing shall be applied to the entire surface of deck and inside faces of parapets or curb plates. Materials and construction to be in accordance with AREMA Manual recommendations, Chapter 29 plus requirements as follows.

B. MEMBRANE WATERPROOFING:

1. Use 3/32" thick Butyl Rubber Membrane waterproofing conforming to the requirements of Article 2.3.5 on the entire deck and ballast retainers.
2. Adhesive must be applied to the entire surface to be waterproofed.
3. No. 3, tongue and groove splice, shown in AREMA Chapter 29, Figure 2-2, shall be used for splicing Butyl Rubber Membrane.

C. WATERPROOFING PROTECTION:

Two layers of asphaltic panels, conforming to AREMA Article 2.4.7, total thickness not less than 1 inch and placed with staggered joints and set in compatible adhesive, shall be used to protect Butyl Rubber Membrane on deck and ballast retainers. Ballast shall be placed as soon as practicable following placement of the panels to prevent distortion from sunlight. Edges and protrusions of panels are to be coated in accordance with Article 2.9.4.6. (A).

VIII. SUBSTRUCTURE:

A. ABUTMENT:

1. The abutment shall be designed in accordance with requirements of Chapter 8 of the AREMA Manual
2. The abutment shall be wide enough to provide for a 15' – 0" shoulder measured from the centerline at the nearest track, on each side. In case of multiple track bridges, the abutment width shall be sufficient to provide for standard 15' – 0" shoulder on both sides and future 15' – 0" center to center between tracks. Wingwalls shall be designed to support 2 horizontal : 1 vertical embankment slope.

3. Provide four inches minimum clearance between end of structural steel and face of backwall.
4. Use front face of backwall and centerline of track as reference for abutment layout.
5. Provide waterstops of all construction joints. Waterstops shall be PVC 9" X 3/8" Hollow Bulb (Bulb ?" I. D., 1 ?" O. D.) continuous across joint.
6. Provide minimum edge distance of six inches from edge of masonry plate or shoe to edge of abutment.

B. PIER:

1. Provide a minimum edge distance of six inches from the front edge or back edge of masonry plate or shoe. In addition, provide a minimum edge distance of six inches from the corner of masonry plate or shoe
2. Provide four inches minimum clear between ends of structural steel.
3. Provide a minimum of eighteen inches beyond the outside edge of the masonry plate or shoe to the end of the pier.
4. Length of pier shall be sufficient to provide for future 15'-0" center to center of tracks, when multiple tracks are supported on one pier.
5. Thickness of pier shall be minimum 4'-0" width measured at the stem.

IX. MAINTENANCE OF RAILROAD TRAFFIC

A. GENERAL

1. It is essential that the construction be performed with a minimum interference with rail traffic. Continuity of safe rail operations will be required for the duration of the project.
2. The Design Engineer should contact Railroad's Division manager in the preliminary design stage to determine Railroad Operational requirements.
3. The most effective method of maintaining traffic is to temporarily reroute traffic around the construction site using detour tracks. Detour tracks will be required where feasible. Railroad's Chief Engineer Design and Construction, will furnish design requirements.
4. If detour tracks cannot be provided, the new superstructure shall be constructed adjacent to final location and rolled into place. Temporary bridges will be required to maintain traffic. Construction plans shall show complete details of temporary bridges and roll-in structure.
5. A detailed construction procedure for maintaining traffic shall be shown on the plans. When construction requires total interruption of rail traffic, an estimate of the time required will be shown in the procedure. This interval must be within the approved time frame furnished by Railroad's Division Manager.
6. Prior to the start of construction, written approval from the Railroad for the procedure of construction must be secured.

X. PLAN PREPARATION AND SUBMITTAL

A. PRELIMINARY PLANS

Provide four (4) sets of type, size and location (T.S.&L.) plans to Railroad for approval. The T.S.&L. plan shall show plan view, elevation and typical cross section of the proposed structure. Furnish cross sections or topographic map with contours and soil exploration data along with T.S.&L. plans. Obtain Railroad approval before proceeding with final design. Railroad will assign a bridge designation when T.S.&L. plans are reviewed. This bridge designation shall be shown on all drawings.

B. FINAL PLANS

Provide four (4) sets of detailed final plans and one set of design calculations for Railroad approval. Submit special provisions or special specifications along with final plans for Railroad approval.

After plans are approved and construction contract is awarded, a copy of the contract shall be provided to the Railroad. Provide one (1) set of original plans or Mylar reproducible tracings (not sepias) of the as built design plans for the Railroad files, after job completion.

C. SHOP DRAWINGS

Provide two (2) complete sets of shop drawings for Railroad review. Welding procedures shall be submitted with the structural steel shop drawings. After completion of the job, furnish one set of original or Mylar reproducible tracings of the shop drawings for Railroad Files.

D. COFFERDAMS AND SHORING PLANS

During construction of the bridge, shoring may be required to support detour track or cofferdams may be needed to construct abutments and piers. Contractor shall submit detailed plans of the cofferdams and/or shoring, along with the construction procedure and one set of calculations to the Railroad and shall secure approval in writing prior to the start of the construction. Plans shall be prepared by a registered Professional Engineer in the State where the cofferdam or shoring is being constructed and shall bear his seal and signature. All pertinent soil data shall be sent to Railroad along with the plans for the shoring or cofferdam.

Shoring to protect Railroad traffic shall be designed to resist a vertical live load surcharge of 1800 lbs per square foot, in addition to active earth pressure. The surcharge shall be assumed to act on a continuous strip, 8'-6" wide. Lateral pressures due to surcharge shall be computed using the strip load formula shown in AREMA Manual, Chapter 8, part 20.

APPENDIX

CSX Transportation

CONSTRUCTION SUBMISSION CRITERIA

Public Projects Group
Jacksonville, FL
Date Issued: February 23, 2015

TABLE OF CONTENTS

INTRODUCTION

SECTION I:	Definitions
SECTION II:	Construction Submissions
SECTION III:	Hoisting Operations
SECTION IV:	Demolition Procedure
SECTION V:	Erection Procedure
SECTION VI:	Temporary Excavation and Shoring
SECTION VII:	Track Monitoring

INTRODUCTION

The intent of this document is to guide outside agencies and their Contractors when performing work on, over, or with potential to impact CSXT property (ROW). Work plans shall be submitted for review to the designated CSXT Engineering Representative for all work which presents the potential to affect CSXT property or operations; this document shall serve as a guide in preparing these work plans. All work shall be performed in a manner that does not adversely impact CSXT operations or safety; as such, the requirements of this document shall be strictly adhered to, in addition to all other applicable standards associated with the construction. Applicable standards include, but are not limited to, CSXT Standards and Special Provisions, CSXT Insurance Requirements, CSXT Pipeline Occupancy Criteria, as well as the governing local, county, state and federal requirements. It shall be noted that this document and all other CSXT standards are subject to change without notice, and future revisions will be made available at the CSXT website: www.csx.com.

I. DEFINITIONS

1. *Agency* – The project sponsor (i.e., State DOT, Local Agencies, Private Developer, etc.)
2. *AREMA* – American Railway Engineering and Maintenance-of-Way Association – the North American railroad industry standards group. The use of this term shall be in specific reference to the AREMA Manual for Railway Engineering.
3. *Construction Submission* – The Agency or its representative shall submit six (6) sets of plans, supporting calculations, and detailed means and methods procedures for the specific proposed activity. All plans, specifications, and supporting calculations shall be signed/sealed by a Professional Engineer as defined below.
4. *Controlled Demolition* – Removal of an existing structure or subcomponents in a manner that positively prevents any debris or material from falling, impacting, or otherwise affecting CSXT employees, equipment or property. Provisions shall be made to ensure that there is no impairment of railroad operations or CSXT's ability to access its property at all times.
5. *Contractor* – The Agency's representative retained to perform the project work.
6. *Engineer* – CSXT Engineering Representative or a GEC authorized to act on the behalf of CSXT.
7. *Flagman* – A qualified CSXT employee with the sole responsibility to direct or restrict movement of trains, at or through a specific location, to provide protection for workers.
8. *GEC* – General Engineering Consultant who has been authorized to act on the behalf of CSXT.
9. *Horizontal Clearance* – Distance measured perpendicularly from centerline of any track to the nearest obstruction at any elevation between TOR and the maximum vertical clearance of the track.
10. *Professional Engineer* – An engineer who is licensed in State or Commonwealth in which the project is to occur. All plans, specifications, and supporting calculations shall be prepared by the Licensed Professional Engineer and shall bear his/her seal and signature.
11. *Potential to Foul* – Work having the possibility of impacting CSXT property or operations; defined as one or more of the following:
 - a. Any activity where access onto CSXT property is required.
 - b. Any activity where work is being performed on CSXT ROW.
 - c. Any excavation work adjacent to CSXT tracks or facilities, within the Theoretical Railroad Live Load Influence Zone, or where the active earth pressure zone extends within the CSXT property limits.
 - d. The use of any equipment where, if tipped and laid flat in any direction (360 degrees) about its center pin, can encroach within twenty five feet (25'-0") of the nearest track centerline. This is based upon the proposed location of

- the equipment during use, and may be a function of the equipment boom length. Note that hoisting equipment with the potential to foul must satisfy the 150% factor of safety requirement for lifting capacities.
- e. Any work where the scatter of debris, or other materials has the potential to encroach within twenty five feet (25'-0") of the nearest track centerline.
 - f. Any work where significant vibration forces may be induced upon the track structure or existing structures located under, over, or adjacent to the track structure.
 - g. Any other work which poses the potential to disrupt rail operations, threaten the safety of railroad employees, or otherwise negatively impact railroad property, as determined by CSXT.
12. *ROW – Right of Way*; Refers to CSXT Right-of-Way as well as all CSXT property and facilities. This includes all aerial space within the property limits, and any underground facilities.
 13. *Submission Review Period* - a minimum of thirty (30) days in advance of start of work. Up to thirty (30) days will be required for the initial review response. Up to an additional thirty (30) days may be required to review any/all subsequent submissions or resubmission.
 14. *Theoretical Railroad Live Load Influence Zone* – A 1½ horizontal to 1 vertical theoretical slope line starting 18 inches (1'-6") below top of tie elevation and twelve feet (12'-0") from the centerline of the nearest track.
 15. *TOR – Top of Rail*. This is the base point for clearance measurements. It refers to the crown (top) of the steel rail; the point where train wheels bear on the steel rails.
 16. *Track Structure* – All load bearing elements which support the train. This includes, but is not limited to, the rail, ties, appurtenances, ballast, sub-ballast, embankment, retaining walls, and bridge structures.
 17. *Vertical Clearance* – Distance measured from TOR to the lowest obstruction within six feet (6'-0") of the track centerline, in either direction.

II. GENERAL SUBMISSION REQUIREMENTS

- A. A construction work plan is required to be submitted by the Agency or its Contractor, for review and acceptance, prior to accessing or performing any work with Potential to Foul.
- B. The Agency or its representative shall submit six (6) sets of plans, specifications, supporting calculations, and detailed means and methods procedures for the specific proposed work activity.
- C. Construction submissions shall include all information relevant to the work activity, and shall clearly and concisely explain the nature of the work, how it is being performed, and what measures are being taken to ensure that railroad property and operations are continuously maintained.
- D. All construction plans shall include a map of the work site, depicting the CSXT tracks, the CSXT right of way, proposed means of access, proposed locations for equipment and material staging (dimensioned from nearest track centerline), as well as all other relevant project information. An elevation drawing may also be necessary in order to depict clearances or other components of the work.
- E. Please note that CSXT will not provide pricing to individual contractors involved in bidding projects. Bidding contractors shall request information from the agency and not CSXT.
- F. The Contractor shall install a geotextile fabric ballast protection system to prevent construction or demolition debris and fines from fouling ballast. The geotextile ballast protection system shall be installed and maintained by the Contractor to the satisfaction of the Engineer.
- G. The Engineer shall be kept aware of the construction schedule. The Contractor shall provide timely communication to the Engineer when scheduling the work such that the Engineer may be present during the work. The Contractor's schedule shall not dictate the work plan review schedule, and flagging shall not be scheduled prior to receipt of an accepted work plan.

H. At any time during construction activities, the Engineer may require revisions to the previously approved procedures to address weather, site conditions or other circumstances that may create a potential hazard to rail operations or CSXT facilities. Such revisions may require immediate interruption or termination of ongoing activities until such time the issue is resolved to the Engineer's satisfaction. CSXT and its GEC shall not be responsible for any additional costs or time claims associated with such revisions.

I. Blasting will not be permitted to demolish a structure over or within CSXT's right-of-way. When blasting off of CSXT property but with Potential to Foul, vibration monitoring, track settlement surveying, and/or other protective measures may be required as determined by the Engineer.

J. Blasting is not permitted adjacent to CSXT right-of-way without written approval from the Chief Engineer, CSXT.

K. Mechanical and chemical means of rock removal must be explored before blasting is considered. If written permission for the use of explosives is granted, the Agency or Contractor must submit a work plan satisfying the following requirements:

1. Blasting shall be done with light charges under the direct supervision of a responsible officer or employee of the Agency or Contractor.
2. Electronic detonating fuses shall not be used because of the possibility of premature explosions resulting from operation of two-way train radios.
3. No blasting shall be done without the presence of an authorized representative of CSXT. Advance notice to the Engineer is required to arrange for the presence of an authorized CSXT representative and any flagging that CSXT may require.
4. Agency or Contractor must have at the project site adequate equipment, labor and materials, and allow sufficient time, to clean up debris resulting from the blasting and correct any misalignment of tracks or other damage to CSXT property resulting from the blasting. Any corrective measures required must be performed as directed by the Engineer at the Agency's or Contractor's expense without any delay to trains. If Agency's or Contractor's actions result in the delay of any trains including passenger trains, the Agency or Contractor shall bear the entire cost thereof.
5. The Agency or Contractor may not store explosives on CSXT property.
6. At any time during blasting activities, the Engineer may require revisions to the previously approved procedures to address weather, site conditions or other circumstances that may create a potential hazard to rail operations or CSXT facilities. Such revisions may require immediate interruption or termination of ongoing activities until such time the issue is resolved to the Engineer's satisfaction. CSXT and its GEC shall not be responsible for any additional costs or time claims associated with such revisions.

III. HOISTING OPERATIONS

A. All proposed hoisting operations with Potential to Foul shall be submitted in accordance with the following:

1. A plan view drawing shall depict the work site, the CSXT track(s), the proposed location(s) of the lifting equipment, as well as the proposed locations for picking, any intermediate staging, and setting the load(s). All locations shall be dimensioned from centerline of the nearest track. Crane locations shall also be dimensioned from a stationary point at the work site for field confirmation.
2. Computations showing the anticipated weight of all picks. Computations shall be made based upon the field-verified plans of the existing structure. Pick weights shall account for the weight of concrete rubble or other materials attached to the component being removed; this includes the weight of subsequent rigging devices/components. Rigging components shall be sized for the subsequent pick weight.
3. All lifting equipment, rigging devices, and other load bearing elements shall have a rated (safe lifting) capacity that is greater than or equal to 150% of the load it is carrying, as a factor of safety. Supporting calculations shall be furnished to verify the minimum capacity requirement is maintained for the duration of the hoisting operation.

4. Dynamic hoisting operations are prohibited when carrying a load with the Potential to Foul. Cranes or other lifting equipment shall remain stationary during lifting. (i.e., no moving picks).
5. For lifting equipment, the manufacturer's capacity charts, including crane, counterweight, maximum boom angle, and boom nomenclature is to be submitted.
6. A schematic rigging diagram must be provided to clearly call out each rigging component from crane hook to the material being hoisted. Copies of catalog or information sheets shall be provided to verify rigging weights and capacities.
7. For built-up rigging devices, the contractor shall submit the following:
 - i. Details of the device, calling out material types, sizes, connections and other properties.
 - ii. Load test certification documents and/or design computations bearing the seal and signature of a Professional Engineer. Load test shall be performed in the configuration of its intended use as part of the subject demolition procedure.
 - iii. Copies of the latest inspection reports of the rigging device. The device shall be inspected within one (1) calendar year of the proposed date for use.
8. A detail shall be provided showing the crane outrigger setup, including dimensions from adjacent slopes or facilities. The detail shall indicate requirements for bearing surface preparation, including material requirements and compaction efforts. As a minimum, outriggers and/or tracks shall bear on mats, positioned on level material with adequate bearing capacity.
9. A complete written narrative that describes the sequence of events, indicating the order of lifts and any repositioning or re-hitching of the crane(s).

IV. DEMOLITION PROCEDURE

- A. The Agency or its Contractor shall submit a detailed procedure for a controlled demolition of any structure on, over, or adjacent to the ROW. The controlled demolition procedure must be approved by the Engineer prior to beginning work on the project.
- B. Existing Condition of structure being demolished:
 1. The Contractor shall submit as-built plans for the structure(s) being demolished.
 2. If as-built plans are unavailable, the Contractor shall perform an investigation of the structure, including any foundations, substructures, etc. The field measurements are to be made under the supervision of the Professional Engineer submitting the demolition procedure. Findings shall be submitted as part of the demolition means and methods submittal for review by the Engineer.
 3. Any proposed method for temporary stabilization of the structure during the demolition shall be based on the existing plans or investigative findings, and submitted as part of the demolition means and methods for review by the Engineer.
- C. Demolition work plans shall include a schematic plan depicting the proposed locations of the following, at various stages of the demolition:
 1. All cranes and equipment, calling out the operating radii.
 2. All proposed access and staging locations with all dimensions referenced from the center line of the nearest track.
 3. Proposed locations for stockpiling material or locations for truck loading.
 4. The location, with relevant dimensions, of all tracks, other railroad facilities; wires, poles, adjacent structures, or buried utilities that could be affected, showing that the proposed lifts are clear of these obstructions.
 5. Note that no crane or equipment may be set on the CSXT rails or track structure and no material may be dropped on CSXT property.
- D. Demolition submittal shall also include the following information:
 1. All hoisting details, as dictated by Section III of this document.
 2. A time schedule for each of the various stages must be shown as well as a schedule for the entire lifting procedure. The proposed time frames for all critical subtasks (i.e., torch/saw cutting various portions of the superstructure or

substructure, dismantling splices, installing temporary bracing, etc.) shall be furnished so that the potential impact(s) to CSXT operations may be assessed and eliminated or minimized.

3. The names and experience of the key Contractor personnel involved in the operation shall be included in the Contractor's means and methods submission.
 4. Design and supporting calculations shall be prepared, signed, and sealed by the Professional Engineer for items including the temporary support of components or intermediate stages shall be submitted for review. A guardrail will be required to be installed in a track in the proximity of temporary bents or shoring towers, when located within twelve feet (12'-0") from the centerline of the track. The guardrail will be installed by CSXT forces, at the expense of the Agency or its contractor.
- E. Girders or girder systems shall be stable at all times during demolition. Temporary bracing shall be provided at the piers, abutments, or other locations to resist overturning and/or buckling of the member(s). The agency shall submit a design and details of the proposed temporary bracing system, for review by the Engineer. Lateral wind forces for the temporary conditions shall be considered in accordance with AREMA, Chapter 8, Section 28.6.2. The minimum lateral wind pressure shall be fifteen pounds per square foot (15 psf).
- F. Existing, obsolete, bridge piers shall be removed to a minimum of three feet (3'-0") below the finished grade, final ditch line invert, or as directed by the Engineer.
- G. A minimum quantity of twenty five (25) tons of CSXT approved granite track ballast may be required to be furnished and stockpiled on site by the Contractor, or as directed by the Engineer.
- H. The use of acetylene gas is prohibited for use on or over CSXT property. Torch cutting shall be performed utilizing other materials such as propane.
- I. CSXT's tracks, signals, structures, and other facilities shall be protected from damage during demolition of existing structure or replacement of deck slab.
- J. Demolition Debris Shield
1. On-track or ground-level debris shields (such as crane mats) are prohibited for use by CSXT.
 2. Demolition Debris Shield shall be installed prior to the demolition of the bridge deck or other relevant portions of the structure. The demolition debris shield shall be erected from the underside of the bridge over the track area to catch all falling debris. The debris shield shall not be the primary means of debris containment.
 - i. The demolition debris shield design and supporting calculations, all signed/sealed by a Professional Engineer, shall be submitted for review and acceptance.
 - ii. The demolition debris shield shall have a minimum design load of 50 pounds per square foot (50 psf) plus the weight of the equipment, debris, personnel, and all other loads.
 - iii. The Contractor shall verify the maximum particle size and quantity of the demolition debris generated during the procedure does not exceed the shield design loads. Shield design shall account for loads induced by particle impact; however the demolition procedure shall be such that impact forces are minimized. The debris shield shall not be the primary means of debris containment.
 - iv. The Contractor shall include installation/removal means and methods for the demolition debris shield as part of the proposed Controlled Demolition procedure submission.
 - v. The demolition debris shield shall provide twenty three feet (23'-0") minimum vertical clearance, or maintain the existing vertical clearance if the existing clearance is less than twenty three feet (23'-0").
 - vi. Horizontal clearance to the centerline of the track should not be reduced unless approved by the Engineer.
 - vii. The Contractor shall clean the demolition debris shield daily or more frequently as dictated either by the approved design parameters or as directed by the Engineer.
- K. Vertical Demolition Debris Shield
1. This type of shield may be required for substructure removals in close proximity to CSXT track and other facilities, as determined by the Engineer.
 2. The Agency or its Contractor shall submit detailed plans with detailed calculations, prepared, signed, and sealed by a Professional Engineer, of the protection shield.

V. ERECTION PROCEDURE

- A. The Agency or its Contractor shall submit a detailed procedure for erection of a structure with Potential to Foul. The erection procedure must be approved by the Engineer prior to beginning work on the project.
- B. Erection work plans shall include a schematic plan depicting the following, at all stages of the construction:
1. All proposed locations of all cranes and equipment, calling out the operating radii.
 2. All proposed access and staging locations with all dimensions referenced from the center line of the nearest track.
 3. All proposed locations for stockpiling material or locations for truck loading.
 4. The location, with relevant dimensions, of all tracks, other railroad facilities; wires, poles, adjacent structures, or buried utilities that could be affected, showing that the proposed lifts are clear of these obstructions.
- C. No crane or equipment may be set on the CSXT rails or track structure and no material may be dropped on CSXT property.
- D. For erection of a structure over the tracks, the following information shall be submitted for review and acceptance by the Engineer, at least thirty (30) days prior to erection:
1. As-built beam seat elevations – field surveyed upon completion of pier/abutment construction.
 2. Current Top of Rail (TOR) elevations – field measured at the time of as-built elevation collection.
 3. Computations verifying the anticipated minimum vertical clearance in the final condition which accounts for all deflection and camber, based upon the current TOR and as-built beam seat elevations. The anticipated minimum vertical clearance shall be greater than or equal to that which is indicated by the approved plans. Vertical clearance (see definitions) is measured from TOR to the lowest point on the overhead structure at any point within six feet (6'-0") from centerline of the track. Calculations shall be signed and sealed by a Professional Engineer.
- E. Girders or girder systems shall be stable at all times during erection. No crane may unhook prior to stabilizing the beam or girder.
1. Lateral wind forces for the temporary conditions shall be considered in accordance with AREMA, Chapter 8, Section 28.6.2. The minimum lateral wind pressure shall be fifteen pounds per square foot (15 psf).
 2. Temporary bracing shall be provided at the piers, abutments, or other locations to resist overturning and/or buckling of the member(s). The agency shall submit a design and details of the proposed temporary bracing system, for review by the Engineer.
 3. Temporary bracing shall not be removed until sufficient lateral bracing or diaphragm members have been installed to establish a stable condition. Supporting calculations, furnished by the Professional Engineer, shall confirm the stable condition.
- F. Erection procedure submissions shall also include the following information:
1. All hoisting details, as dictated by Section III of this document.
 2. A time schedule for each of the various stages must be shown as well as a schedule for the entire lifting procedure. The proposed time frames for all critical subtasks (i.e., performing aerial splices, installing temporary bracing, installation of diaphragm members, etc.) shall be furnished so that the potential impact(s) to CSXT operations may be assessed and eliminated or minimized.
 3. The names and experience of the key Contractor personnel involved in the operation shall be included in the Contractor's means and methods submission.
 4. A guardrail will be required to be installed in a track in the proximity of temporary bents or shoring towers, when located within twelve feet (12'-0") from the centerline of the track. The guardrail will be installed by CSXT forces, at the expense of the Agency or its Contractor.
 5. Design and supporting calculations prepared by the Professional Engineer for items including the temporary support of components or intermediate stages shall be submitted for review.

VI. TEMPORARY EXCAVATION AND SHORING

- A. The Agency or its Contractor shall submit a detailed design and procedure for the installation of a sheeting/shoring system adjacent to the tracks. Shoring protection shall be provided when excavating with Potential to Foul, or as otherwise determined by CSXT. Shoring shall be provided in accordance with the AREMA, except as noted below.
- B. Shoring may not be required if all of the following conditions are satisfied:
1. The excavation does not encroach within the Theoretical Live Load Influence Zone. Please refer to Figure 1.
 2. The track structure is situated on level ground, or in a cut section, and on stable soil.
 3. The excavation does not adversely impact the stability of a CSXT facility (i.e. signal bungalow, drainage facility,

undergrade bridge, building, etc), or the stability of any structure on, over, or adjacent to CSXT property with potential to foul.

4. Shoring is not required by any governing federal, state, local or other construction code.

- C. Shoring is required when excavating the toe of an embankment. Excavation of any embankment which supports an active CSXT track structure without shoring will not be permitted.
- D. Trench boxes are not an acceptable means of shoring. Trench boxes are prohibited for use on CSXT property or within the Theoretical Railroad Live Load Influence Zone.
- E. Shoring shall be a cofferdam-type, which completely encloses the excavation. However, where justified by site or work conditions, partial cofferdams with open sides away from the track may be permissible, as determined by the Engineer.
- F. Cofferdams shall be constructed using interlocking steel sheet piles, or when approved by the Engineer, steel soldier piles with timber lagging. Wales and struts shall be included when dictated by the design.
- G. The use of tiebacks can be permissible for temporary shoring systems, when conditions warrant. Tiebacks shall have a minimum clear cover of 6'-0", measured from the bottom of the rail. Upon completion of the work, tiebacks shall be grouted, cut off, and remain in place.
- H. All shoring systems on, or adjacent to CSXT right-of-way, shall be equipped with railings or other fall protection, compliant with the governing federal, state or local requirements. Area around pits shall be graded to eliminate all potential tripping hazards.
- I. Interlocking steel sheet piles shall be used for shoring systems qualifying one or more of the following conditions:
 - 1. Within 18'-0" of the nearest track centerline
 - 2. Within the live load influence zone
 - 3. Within slopes supporting the track structure
 - 4. As otherwise deemed necessary by the Engineer.
- J. Sheet piles qualifying for one or more of the requirements listed in Section VI.I (above) of this document shall not be removed. Sheet piles shall be left in place and cut off a minimum of 3'-0" below the finished grade, the ditch line invert, or as otherwise directed by the Engineer. The ground shall be backfilled and compacted immediately after sheet pile is cut off.
- K. The following design considerations shall be considered when preparing the shoring design package:
 - 1. Shoring shall be designed to resist a vertical live load surcharge of 1,880 lbs. per square foot, in addition to active earth pressure. The surcharge shall be assumed to act on a continuous strip, eight feet six inches (8'-6") wide. Lateral pressures due to surcharge shall be computed using the strip load formula shown in *AREMA Manual for Railway Engineering*, Chapter 8, Part 20.
 - 2. Allowable stresses in materials shall be in accordance with AREMA Chapter 7, 8, and 15.3.
 - 3. A minimum horizontal clearance of ten feet (10'-0") from centerline of the track to face of nearest point of shoring shall be maintained, provided a twelve feet (12'-0") roadbed is maintained with a temporary walkway and handrail system.
 - 4. For temporary shoring systems with Potential to Foul, piles shall be plumb under full dead load. Maximum deflection at the top of wall, under full live load, shall be as follows:
 - i. One-half (1/2) inch for walls within twelve feet (12'-0") of track centerline (Measured from centerline of the nearest track to the nearest point of the supporting structure).
 - ii. One (1) inch for walls located greater than twelve feet (12'-0") from track centerline
- L. Shoring work plans shall be submitted in accordance with Section II of this document, as well as the following additional requirements:
 - 1. The work plan shall include detailed drawings of the shoring systems calling out the sizes of all structural members, details of all connections. Both plan and elevation drawings shall be provided, calling out dimensions from the face of shoring relative to the nearest track centerline. The elevation drawing shall also show the height of shoring, and track elevation in relation to bottom of excavation.
 - 2. Full design calculations for the shoring system shall be furnished.
 - 3. A procedure for cutting off the sheet pile, backfilling and restoring the embankment.

VII. TRACK MONITORING

- A. When work being performed has the potential to disrupt the track structure, a work plan must be submitted detailing a track monitoring program which will serve to monitor and detect both horizontal and vertical movement of the CSXT track and roadbed.
- B. The program shall specify the survey locations, the distance between the location points, and frequency of monitoring before, during, and after construction. CSXT reserves to the right to modify the survey locations and monitoring frequency as necessary during the project.
- C. The survey data shall be collected in accordance with the approved frequency and immediately furnished to the Engineer for analysis.
- D. If any movement has occurred as determined by the Engineer, CSXT will be immediately notified. CSXT, at its sole discretion, shall have the right to immediately require all contractor operations to be ceased, have the excavated area immediately backfilled and/or determine what corrective action is required. Any corrective action required by CSXT or performed by CSXT including the monitoring of corrective action of the contractor will be at project expense.

FIGURE 1: Theoretical Live Load Influence Zone

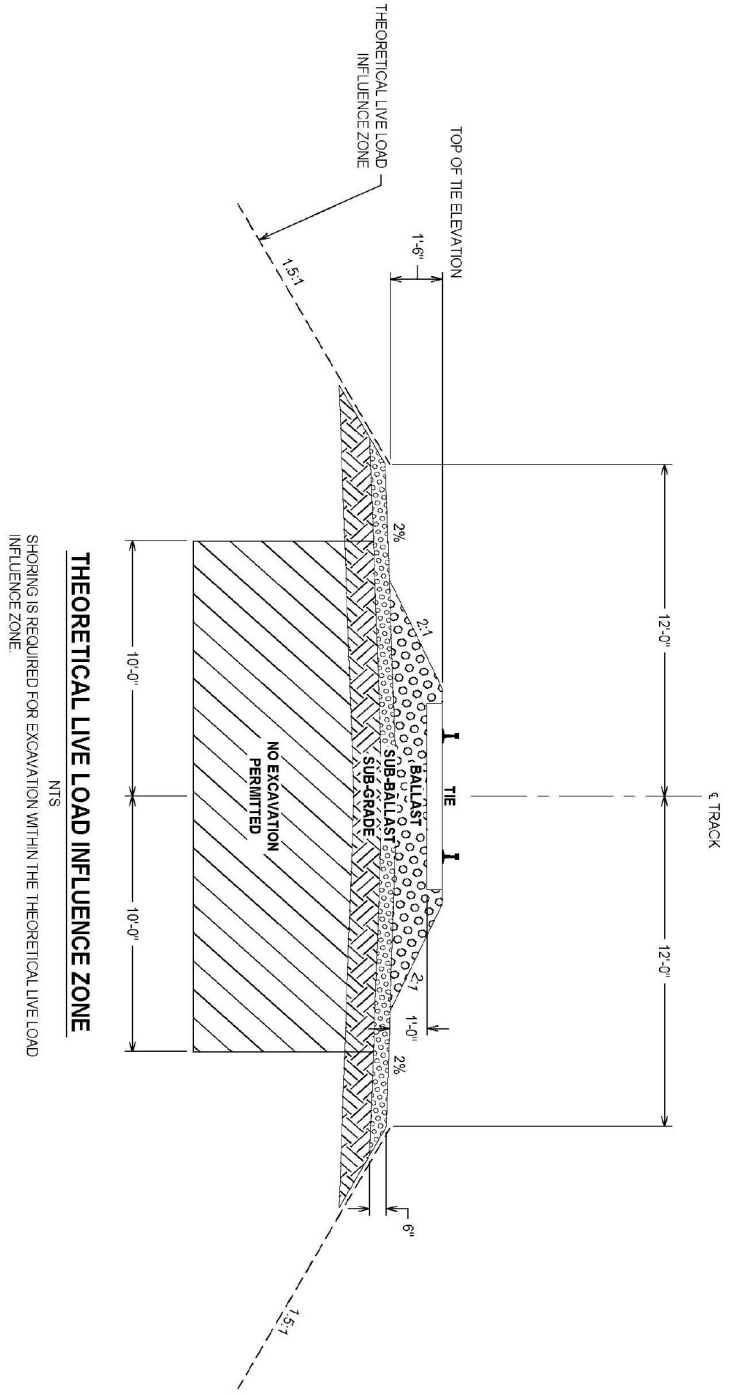

NOTES:

1. THEORETICAL LIVE LOAD INFLUENCE ZONE IS A $1 \frac{1}{2}$ HORIZONTAL TO 1 VERTICAL, THEORETICAL SLOPE STARTING 1'-6" BELOW TOP OF THE ELEVATION AND 12'-0" FROM THE CENTERLINE OF THE NEAREST TRACK.
2. REFER TO CONSTRUCTION SUBMISSION CRITERIA FOR ADDITIONAL REQUIREMENTS.
3. SHORING SHALL BE DESIGNED TO RESIST A VERTICAL LIVE LOAD SURCHARGE OF 1,880 LBS. PER SQUARE FOOT, IN ADDITION TO ACTIVE EARTH PRESSURE. THE SURCHARGE SHALL BE ASSUMED TO ACT ON A CONTINUOUS STRIP, 8'-6" WIDE. LATERAL PRESSURES DUE TO SURCHARGE SHALL BE COMPUTED USING THE STRIP LOAD FORMULA SHOWN IN AREMA MANUAL FOR RAILWAY ENGINEERING, CHAPTER 8, PART 2D.

APPENDIX

CSX Transportation

DRAINAGE CRITERIA

CSXT Design and Construction
Public Projects Group
Jacksonville, FL
Date Issued: September 9, 2014

TABLE OF CONTENTS

INTRODUCTION

SECTION I: Definitions

SECTION II: CSXT General Design Requirements

SECTION III: Plans

SECTION IV: Calculations & Reports

SECTION V: Construction Specifications .

INTRODUCTION

CSXT owns its right-of-way for the primary purpose of operating a railroad. All drainage occupancies shall therefore be designed and constructed so that rail operations and facilities are not interfered with, interrupted, or endangered. In addition, the proposed facility shall be located to minimize encumbrance to the right-of-way so that the railroad will have unrestricted use of its property for current and future operations.

The CSX Design & Construction Standard Specifications for Pipelines, last revised February 24, 2010 shall serve as the overarching authority for recommended practice in providing sufficient drainage and protective measures for projects on CSXT property. The intent of this document is to provide criteria which supplements, modifies and/or supersedes the applicable sections of the AREMA Manual when designing a project which can affect drainage on or about the CSXT ROW. Additionally, these requirements help guide an outside party through the necessary procedures for interacting with CSXT and delivering an acceptable design.

I. DEFINITIONS

1. *Agency* – The project sponsor (i.e. State DOT, Local Agencies, Private Developer, etc.)
2. *AREMA* – American Railway Engineering and Maintenance-of-Way Association – the North American railroad industry standards group. The use of this term shall be in specific reference to the *AREMA Manual for Railway Engineering*.
3. *Construction Submission* – The Agency or its representative shall submit six (6) sets of plans, supporting calculations, and detailed means and methods procedures for the specific proposed activity. All plans, specifications, and supporting calculations shall be signed/sealed by a Professional Engineer as defined below.
4. *Controlled Demolition* – Removal of an existing structure or subcomponents in a manner that positively prevents any debris or material from falling, impacting, or otherwise affecting CSXT employees, equipment or property. Provisions shall be made to ensure that there is no impairment of railroad operations or CSXT's ability to access its property at all times.
5. *Contractor* – The Agency's representative retained to perform the project work.
6. *Engineer* – CSXT Engineering Representative or a GEC authorized to act on the behalf of CSXT.
7. *Flagman* – A qualified CSXT employee with the sole responsibility to direct or restrict movement of trains, at or through a specific location, to provide protection for workers.
8. *GEC* – General Engineering Consultant who has been authorized to act on the behalf of CSXT. GECs perform preliminary engineering, construction inspection, and monitoring under the direction of the CSXT Engineering personnel. GEC personnel also perform day-to-day administration of certain types of projects.
9. *Horizontal Clearance* – Distance measured perpendicularly from centerline of any track to the nearest obstruction at any elevation between TOR and the maximum vertical clearance of the track.
10. *Professional Engineer* – An engineer who is licensed in State or Commonwealth in which the project is to occur. All plans, specifications, and supporting calculations shall be prepared by the Professional Engineer and shall bear his seal and signature.
11. *Potential to Encroach* – Work having the possibility of impacting CSXT property or operations; defined as one or more of the following:
 - a. Any activity where access onto CSXT property is required.
 - b. Any activity where work is being performed on CSXT ROW.
 - c. Any excavation work adjacent to CSXT tracks or facilities, within the Theoretical Railroad Live Load Influence Zone, or where the active earth pressure zone extends within the CSXT property limits.

- d. The use of any equipment where, if tipped and laid flat in any direction (360 degrees) about its center pin, can encroach within twenty five feet (25'-0") of the nearest track centerline. This is based upon the proposed location of the equipment during use, and may be a function of the equipment boom length. Note that hoisting equipment with the potential to foul must satisfy the 150% factor of safety requirement for lifting capacities.
- e. Any work where the scatter of debris or other materials has the potential to encroach within twenty five feet (25'-0") of the nearest track centerline.
- f. Any work where significant vibration forces may be induced upon the track structure or existing structures located under, over, or adjacent to the track structure.
- g. Any other work which poses the potential to disrupt rail operations, threaten the safety of railroad employees, or otherwise negatively impact railroad property, as determined by CSXT.

12. *ROW* – Right of Way; Refers to CSXT Right-of-Way as well as all CSXT property and facilities. This includes all aerial space within the property limits, and any underground facilities.

13. *Submission Review Period* - A minimum of 30 days will be required for the initial review response. Up to an additional 30 days may be required to review any/all subsequent submissions or resubmission.

14. *Theoretical Railroad Live Load Influence Zone* – A 1½ horizontal to 1 vertical theoretical slope line starting 1'-6" below TOR elevation and 12'-0" from the centerline of the nearest track.

15. *TOR* – Top of Rail. This is the base point for clearance measurements. It refers to the crown (top) of the steel rail; the point where train wheels bear on the steel rails. Use the higher of the two rails when track is superelevated.

16. *Track Structure* – All load bearing elements which support the train. This includes, but is not limited to, the rail, ties, appurtenances, ballast, sub-ballast, embankment, retaining walls, and bridge structures.

17. *Vertical Clearance* – Distance measured from TOR to the lowest obstruction, within six feet (6'-0") of the track centerline, in either direction.

II. CSXT GENERAL DESIGN REQUIREMENTS

A. Refer to CSX's Design & Construction Standard Specifications for Pipeline Occupancies, last dated February 24, 2010, for the design requirements for all pipes and drainage structures under the railroad.

B. All pipes, ditches, and other structures carrying surface drainage on CSXT property and/or under CSXT track(s) shall be designed to carry the run-off from a one hundred (100) year, 24-hour design storm without ponding of water against the roadbed.

C. Pipe(s) used to carry surface drainage on CSXT's right-of-way shall have a minimum diameter of 24 inches.

D. When calculating the capacity of existing or proposed drainage structures, under CSXT's track(s), the headwater calculation at the structure shall not be greater than one (1):

$$HW/D \leq 1.$$

E. Rate and quantity of storm water runoff from any proposed development shall not exceed the rate and quantity of runoff prior to development. This standard shall be maintained for all design storms up to the 100 year storm event.

F. Pipes (casing or carrier) placed under CSXT tracks shall not be less than 5.5 feet from base of rail to top of pipe at its shallowest point.

G. Pipelines laid longitudinally on CSXT's right-of-way, 50 feet or less from centerline of track shall be buried not less than 4 feet from ground surface to top of pipe. Where the pipeline is laid more than 50 feet from centerline of track, the minimum cover shall be at least 3 feet.

H. Erosion prevention methods shall be used to protect railroad ditches and other drainage facilities during construction on and adjacent to CSXT's right-of-way.

- I. Permanent erosion and sediment pollution control facilities shall be designed for the 100-year storm. Provide calculations and details of any riprap outlet protection and channel linings as needed within CSXT right-of-way.
- J. Pipes and culverts within the live load influence shall conform to current AREMA Recommendations and ASTM Specifications. All such structures shall be designed to carry Cooper's E-80 loading with diesel impact. Refer to CSX's Design & Construction Standard Specifications for Pipeline Occupancies approved material types and specifications.
- K. CSXT right-of-way shall not be utilized for retention, detention or settling basins. Also, the railroad embankment must not be used as any part of a detention pond structure.
- L. Track roadbed fills shall not be used as dams or levees for retention of runoff.
- M. Temporary sediment basins/traps shall not be constructed against track roadbed fill.
- N. Formal approval of the proposed design, by the appropriate governmental agency having jurisdiction, shall be submitted to CSXT for their review and acceptance.
- O. Pipes and culverts are not to be located within the limits of a turnout or nor closer than 45 feet to any railroad bridge, building or any other important structure.
- P. When excavation for a pipeline or other structure will be within the theoretical railroad embankment line of an adjacent track, interlocking steel sheet piling will be required to protect the track(s). Trench Boxes are prohibited for use on CSXT within the Theoretical Railroad Live Load Influence Zone. Please refer to the CSX Transportation, Construction Submission Criteria for further details regarding sheeting.
- Q. Blasting is not permitted on or adjacent to CSXT right-of-way without prior written approval from the Chief Engineer, CSXT.
- R. Crossing of tracks at grade by equipment and personnel is prohibited except by prior arrangement with and as directed by, CSXT.
- S. Temporary Track Supports may be required when jacking, boring or tunneling method of installation is used, and depending upon the size and location of the drainage crossing. The Agency's contractor shall furnish and supply the CSX approved track supports, with the installation and removal performed by CSXT employees. The Agency shall reimburse CSXT for all costs associated with the installation and removal of the track supports.
- T. Plans submitted to CSXT for approval shall be prepared by a Professional Engineer and should indicate design, suitable topographic plan, and outline of total drainage area.
- U. If the drainage is to discharge into an existing drainage channel on CSXT's right-of-way and/or through a drainage structure under CSXT's track(s), the computations must include the hydraulic analysis of any existing ditch and/or structure.
- V. Extension of pipes, culverts and other drainage structures previously installed under CSXT owned track shall be made with culvert or drainage structure having the same size, shape, and dimensions, as the existing pipe. In no case shall the existing drainage structure be extended so that the hydraulic capacity is decreased or obstructed. In some cases, it may be necessary to extend existing outlets with pipe or culvert of a larger size. Details of connections to mismatched culverts shall be submitted for CSXT approval.
- W. Agency may be required to provide reasonable corrective measures to alleviate an existing drainage problem within CSXT property which may be affected by the proposed development. It shall be the responsibility of the Agency to obtain all drainage easements and permits. CSXT shall be indemnified and held harmless of any liability.
- X. Agency is to provide information on groundwater recharge if infiltration is proposed adjacent to CSXT property. Soils testing and certification by a registered professional engineer shall be required.
- Y. Emergency spillways discharging onto CSXT property are to be designed and constructed so that the basin berm is protected against erosion.
- Z. Energy dissipating devices are to be placed at all outlets discharging to CSXT property.

AA. Concrete end walls shall be placed at outlets discharging to CSXT property. All concrete outlet pipes on CSXT property must be equipped with a trash rack.

BB. Under no conditions shall any person be allowed to modify, alter or change a previously approved storm water management (SWM) facility discharging to CSXT property unless an approved alternate facility is approved by CSXT.

CC. Design of the drainage system, including alterations of the existing drainage system on CSXT right-of-way, is the responsibility of the Agency. Drainage shall not be diverted, directed toward CSXT, or increased in quantity without prior approval and agreement with CSXT.

DD. Supporting calculations must be provided for all proposed drainage and storm water management facilities that discharge onto or impact CSXT property.

EE. Occupancies shall be designed, and their construction shall be accomplished, so that adequate and uninterrupted drainage of CSXT's rights-of way is maintained.

FF. If, in the course of construction, it may be necessary to block a ditch, pipe, or other drainage facility, temporary pipes, ditches, or other proposed drainage facilities shall be installed to maintain adequate drainage, as approved by CSXT. Upon completion of the Project, the temporary facilities shall be removed and the permanent facilities restored.

GG. Temporary and permanent erosion control and sedimentation (E&S) devices must be provided to prevent the flow of sediment onto and adjacent to CSXT property.

HH. The design shall take into account and provide upstream areas within the entire watershed in computing discharge, sizing of pipes, inlets, and other structures.

II. When applicable, Agency is to provide maintenance and operation of E&S/Storm water facilities.

III. PLANS

A. Plans shall include the following, but not limited to:

1. Existing property boundaries, easements, etc.
2. Existing drainage features and topography.
3. Existing utility locations
4. Existing structures, tracks, roads, features, etc.
5. Existing topography including wetlands and all environmental features.
6. Delineate & Dimension proposed property acquisition or property easements.
7. Dimension distances from all temporary and proposed E&S and storm water management facilities to CSXT's property line and/or easement.
8. Dimension distances from all temporary and proposed E&S and storm water management facilities to CSXT's tracks
9. Dimension all temporary and proposed encroachments within CSXT's property
10. Show existing contours
11. Provide TOR elevations.
12. Provide proposed contours, site grading and drainage facilities
13. Provide proposed improvements, including easements and property lines and limit of disturbance

14. Details for all temporary and proposed drainage structures, SWM and E&S Best Management Practices (BMP) devices
15. Detail proposed E&S, SWM, drainage collection & conveyance systems (pipes, ditches, etc.)
 - i. Provide location, size, slope & type of pipe.
 - ii. Ditch cross sections
 - iii. Invert elevations
 - iv. Grate and rim elevations
16. If applicable, identify the 100-year floodplain if project is within a specified flood zone.
17. Provide E&S Plans in compliance with all State and Local requirements.
18. Signature and Seal of State Licensed PE

IV. CALCULATIONS & REPORTS

A. Design Calculations:

1. Pre and post development Drainage Area Maps
 - i. Provide soils boundary lines & soil types
 - ii. Delineate drainage areas
 - iii. Time of Concentration (Tc) flow path
 - iv. Provide weighted CN and c-values (as applicable to design method)
2. Pre-development 100-year runoff volume and flows for all facilities draining to or on CSXT ROW
3. Post-development 100-year runoff volume and flows for all facilities draining to or on to CSXT ROW
 - i. Verify no increase in rate or quantity of runoff to CSXT property from Pre-Development conditions
 - ii. Provide hydraulic analysis (depth and velocity calculations) for all facilities draining to or on CSXT ROW (existing and proposed) and verify sufficient capacity for proposed flow is provided.
4. Design of proposed collection & conveyance systems (pipes, ditches, etc.)
 - i. CSXT requires capacity for a 100 year, 24 hour storm
 - ii. CSXT requires a minimum diameter of 24-inches for pipes within CSXT ROW
5. Provide all temporary and permanent E&S and SWM BMP calculations
6. Signature and Seal of State Licensed PE

B. Project narrative/summary describing proposed improvements, drainage design, SWM and E&S methodologies, site soil and geological conditions (if known), flooding characteristics (if applicable) and State and Local requirements used to produce designs.

C. Recommended: Photographs of the site and adjacent CSXT property, as well as discharge locations and drainage facilities on CSXT property to receive runoff from the proposed development.

V. CONSTRUCTION SPECIFICATIONS

A. Construction shall be in accordance to the CSX Design & Construction Standard Specifications for Pipeline Occupancies, last revised February 24, 2010 or latest revision, under the Construction Requirements section.

B. All work on or near CSXT property shall be conducted in accordance with CSXT safety rules and regulations. Specifically all Agency's employees and Contractors, while on CSXT property, shall be required to wear a hard hat, safety glasses with side shields, 6" lace up boots with a distinct heel, shirts with sleeves, and long pants; additional personal protective equipment may be required based on certain operations. The Contractor and its employees shall comply with the CSXT safety rules at all times while occupying CSXT's property. Operations will be subject to CSXT inspection at any and all times. All personnel operating equipment must be qualified on it to perform task at hand.

C. For the installation of temporary or permanent shoring systems, including but not limited to soldier piles and lagging, and interlocked steel sheeting on or adjacent to CSXT's right-of-way, the contractor may be required to submit a detailed track monitoring program for CSXT's approval prior to performing any work near CSXT's right-of-way. Please refer to CSX Transportation, Construction Submission Criteria for additional information.

D. When water is known or expected to be encountered all plans and specifications must be submitted to the Engineer for approval before the process begins. Pumps of sufficient capacity to handle the flow shall be maintained at the site, provided the contractor has received approval from CSXT to operate them. Pumps in operation shall be constantly attended on a 24-hour basis until, in the sole judgment of CSXT, the operation can be safely halted. When dewatering, a process for monitoring for any settlement of track or structures must be in place.

E. If any track movement has occurred as determined by the Engineer, CSXT will be immediately notified. CSXT, at its sole discretion, shall have the right to immediately require all contractor operations to be ceased, have the excavated area immediately backfilled and/or determine what corrective action is required. Any corrective action required by CSXT or performed by CSXT including the monitoring of corrective action of the contractor will be at project expense.

F. Installation by the open cut method is not approved under CSXT's mainline tracks, tracks carrying heavy tonnage or tracks carrying passenger trains. Also, open cut shall not be used within the limits of a highway/railroad grade crossing or its approaches, 25 feet either side of traveled way, where possible.

CSX TRANSPORTATION, INC.
500 Water Street
Jacksonville, FL 32202
www.csx.com

HOW TOMORROW MOVES

