

CHAPTER 2

GEOMETRIC

DESIGN CRITERIA

TDOT ROADWAY DESIGN GUIDELINES
CHAPTER 2 GEOMETRIC DESIGN CRITERIA

English

Revised: 04/24/2023

CHAPTER 2 GEOMETRIC DESIGN CRITERIA

Table of Contents

INTRODUCTION	vi
SECTION 1 – CONTROLLING GEOMETRIC DESIGN CRITERIA	1
2-100.00 CONTROLLING CRITERIA FOR DESIGN	1
2-101.00 HORIZONTAL DESIGN	1
2-101.01 HORIZONTAL CURVE RADIUS AND SUPERELEVATION RATES.....	1
2-101.02 TRAVEL, THROUGH, AND TURN LANE WIDTHS	3
2-101.03 SHOULDER WIDTHS.....	3
2-101.04 CROSS SLOPES	4
2-102.00 VERTICAL DESIGN.....	4
2-102.01 VERTICAL GRADES.....	5
2-102.02 STOPPING SIGHT DISTANCE	5
2-102.03 STOPPING SIGHT DISTANCE ON HORIZONTAL AND VERTICAL INTERSECTIONS.....	5
2-102.04 STOPPING SIGHT DISTANCE ON HORIZONTAL AND VERTICAL CURVES	5
2-102.05 VERTICAL CLEARANCES FOR BRIDGES.....	7
2-103.00 DESIGN SPEED.....	8
2-104.00 DESIGN LOADING STRUCTURAL CAPACITY.....	8
2-105.00 DESIGN EXCEPTION REQUESTS.....	8
SECTION 2 – NON-CONTROLLING GEOMETRIC DESIGN CRITERIA	18
2-200.00 NON-CONTROLLING GEOMETRIC DESIGN CRITERIA.....	18
2-200.01 PASSING SIGHT DISTANCE.....	18
2-200.02 VERTICAL CURVES	18
2-200.03 ROADSIDE SLOPE DEVELOPMENT	19
2-200.04 CLEAR ZONE	20
2-200.05 DESIGN VEHICLE	21
2-200.06 MULTIMODAL FACILITIES	22
2-201.00 DESIGN WAIVER REQUESTS	22
SECTION 3 – INTERSECTIONS	29

TDOT ROADWAY DESIGN GUIDELINES
CHAPTER 2 GEOMETRIC DESIGN CRITERIA

English

Revised: 04/24/2023

2-300.00	INTERSECTIONS.....	29
2-301.00	LANE DROP AFTER INTERSECTION	29
2-302.00	TURNING LANES AT INTERSECTIONS.....	32
2-303.00	J-TURN INTERSECTIONS	35
2-304.00	INTERSECTIONS LOCATED NEAR THE LIMITS OF CONSTRUCTION.....	36
SECTION 4 – INTERCHANGES.....		37
2-400.00	INTERCHANGES	37
2-400.01	INTERCHANGE RAMP DESIGN.....	37
2-400.02	TWO-LANE ENTRANCE RAMPS ON FREEWAYS AND EXPRESSWAYS ..	38
2-400.03	ACCESS CONTROL AT INTERCHANGE RAMPS.....	39
SECTION 5 – MEDIANS.....		40
2-500.00	MEDIANS	40
2-500.01	MEDIAN OPENING SPACING	40
2-500.02	MEDIAN OPENING SPACING - EXAMPLES	40
2-500.03	LEFT TURN LANES IN MEDIANS.....	44
SECTION 6 – STRUCTURAL DESIGN.....		47
2-600.00	CONCRETE BOX AND SLAB TYPE CULVERTS AND BRIDGES	47
2-600.01	TYPE DESIGNATION.....	47
2-600.02	PAVED APRON FOR BOX CULVERT AND BRIDGE OUTLETS	47
2-600.03	CONCRETE BOX AND SLAB TYPE CULVERTS AND BRIDGES IN SHALLOW FILLS.....	47
2-600.04	STEEL BAR REINFORCEMENT (ROADWAY)	53
2-601.00	HAUL ROADS	53
2-601.01	HAUL ROAD DESIGN CONSIDERATIONS	53
2-601.02	HAUL ROAD COMPENSATION.....	54
2-601.03	HAUL ROAD TYPICAL SECTION	55
SECTION 7 – EARTHWORK DESIGN		56
2-700.00	EARTHWORK CONSIDERATIONS.....	56
2-701.00	EARTHWORK BALANCES ON WIDENING OF EXISTING ROADWAYS	58
2-702.00	SHRINKAGE AND SWELL FACTORS	58
2-703.00	GRADING LINE THROUGH SOLID ROCK	59

TDOT ROADWAY DESIGN GUIDELINES
CHAPTER 2 GEOMETRIC DESIGN CRITERIA

English

Revised: 04/24/2023

2-704.00	PRESPLITTING OF ROCK EXCAVATION	60
2-705.00	CAPPING ROCK FILLS.....	60
2-706.00	EARTHWORK BALANCES IN PLANS.....	60
2-707.00	TOPSOIL REQUIREMENTS FOR EARTHWORK BALANCES	61
2-708.00	ESTIMATED GRADING QUANTITIES TABULATED BLOCK.....	62
2-709.00	GRADING REPORT	64
SECTION 8 – TRUCK CLIMBING LANES		65
2-800.00	TRUCK CLIMBING LANE DESIGN	65
2-800.01	LOCATION GUIDELINES.....	65
2-800.02	CAPACITY ANALYSIS	66
2-800.03	CRITICAL LENGTH OF GRADE	66
2-800.04	DESIGN CRITERIA	72
2-800.05	DOWNGRADES.....	76
2-800.06	TRUCK SPEED PROFILE	76
SECTION 9 – RETAINING WALL DESIGN.....		81
2-900.00	RETAINING WALLS	81
2-900.01	RETAINING WALL SHEET NAMES, NUMBER, AND ORDER IN PLANS.....	81
2-900.02	DEVELOP THE RETAINING WALL GEOMETRIC LAYOUT SHEET	83
2-900.03	RETAINING WALL ASSESSMENT AT SITE REVIEW	91
2-900.04	GUIDELINES FOR CATEGORY ONE RETAINING WALLS.....	92
2-900.05	GUIDELINES FOR CATEGORY TWO RETAINING WALLS	93
2-900.06	DECORATIVE FACING ON RETAINING WALLS	94
2-900.07	RETAINING WALL QUANTITIES	94
2-900.08	R.O.W. FUNDING REQUEST AND R.O.W. REVISIONS	96
2-900.09	CONSTRUCTION FIELD REVIEW, SUBMITTAL, AND REVISIONS	97
2-900.10	RETAINING WALL FOOTNOTES ON CONSTRUCTION PLANS	97
2-900.11	RETAINING WALL BARRIER SYSTEM REQUIREMENTS.....	98
SECTION 10 - ROUNDABOUT DESIGN		99
2-1000.00	ROUNDABOUT DESIGN PRINCIPLES.....	99
2-1001.00	GENERAL ROUNDABOUT DESIGN CONSIDERATIONS	99

TDOT ROADWAY DESIGN GUIDELINES
CHAPTER 2 GEOMETRIC DESIGN CRITERIA

English

Revised: 04/24/2023

2-1001.01	DESIGN SPEED AND DESIGN VEHICLE SELECTION FOR ROUNDABOUTS	99
2-1001.02	HORIZONTAL ALIGNMENT CONSIDERATIONS FOR ROUNDABOUTS ..	100
2-1001.03	LONGITUDINAL GRADE CONSIDERATIONS FOR ROUNDABOUTS	101
2-1001.04	RIGHT-OF-WAY REQUIREMENTS FOR ROUNDABOUTS.....	101
2-1001.05	CONSIDERATIONS FOR HIGH SPEED APPROACHES AND RURAL LOCATIONS FOR ROUNDABOUTS	102
2-1001.06	GRADING AND DRAINAGE CONSIDERATIONS FOR ROUNDABOUTS ..	103
2-1002.00	GEOMETRIC DESIGN ELEMENTS FOR ROUNDABOUTS.....	104
2-1003.00	ROUNDABOUT DESIGN CHECKS AND MEASUREMENTS	108
2-1004.00	ROADWAY DESIGN CONSIDERATIONS FOR ROUNDABOUTS	117
2-1004.01	DETERMINING ROUNDABOUT LOCATION	117
2-1004.02	ROUNDABOUT PROXIMITY TO OTHER INTERSECTIONS.....	117
2-1004.03	ACCESS MANAGEMENT AND PRIVATE DRIVEWAYS AT ROUNDABOUTS	117
2-1004.04	RAILROAD CROSSINGS AT ROUNDABOUTS.....	118
2-1004.05	SERIES OF ROUNDABOUTS.....	118
2-1004.06	ROUNDABOUTS USED AT INTERCHANGES	118
2-1005.00	PEDESTRIAN, BICYCLE, AND PROWAG CONSIDERATIONS FOR ROUNDABOUTS	119
2-1006.00	SIGNING AND PAVEMENT MARKING FOR ROUNDABOUTS	121
2-1007.00	ROADWAY LIGHTING FOR ROUNDABOUTS.....	121
2-1008.00	LANDSCAPING GUIDELINES FOR ROUNDABOUTS.....	122
SECTION 11	– ROAD RECONFIGURATION AND ROAD DIET.....	124
2-1100.00	ROAD RECONFIGURATION.....	124
2-1101.00	ROAD DIET	124
SECTION 12	– DRIVEWAYS.....	124
2-1200.00	DRIVEWAYS	124
2-1201.00	DRIVEWAY TYPICAL SECTION AND DESIGN CRITERIA.....	128
2-1201.01	DRIVEWAY VERTICAL CURVES	128
2-1201.02	DRIVEWAY HORIZONTAL CURVES.....	129
2-1201.03	DRIVEWAY CROSS SLOPE	129

TDOT ROADWAY DESIGN GUIDELINES
CHAPTER 2 GEOMETRIC DESIGN CRITERIA

English

Revised: 04/24/2023

2-1201.04	DRIVEWAY EDGE	129
2-1201.05	DRIVEWAY APRONS	130
2-1201.06	DRIVEWAY SIDE DRAINS.....	130
2-1202.00	MULTIMODAL ROADWAY DESIGN IN DRIVEWAYS.....	130
2-1203.00	GUIDELINES FOR CONSTRUCTION AND RESURFACING OF DRIVEWAYS ON HIGHWAY PROJECTS	130
2-1203.01	GENERAL	130
2-1203.02	RESURFACING	131
2-1203.03	NEW OR RECONSTRUCTION	132

TDOT ROADWAY DESIGN GUIDELINES
CHAPTER 2 GEOMETRIC DESIGN CRITERIA

English

Revised: 04/24/2023

INTRODUCTION

ROADWAY DESIGN GUIDELINES AND STANDARD DRAWINGS

Roadway Design Guidelines and Standard Drawings have been created to ensure that there is consistency in TDOT projects across the state. The Roadway Design Guidelines and Standard Drawings indicate the current recognized design standards for new construction or reconstruction of existing highways and shall be utilized while giving due regard to topography, natural conditions, availability of road material, and prevailing traffic conditions.

Throughout these guidelines you will see the following terms used. To clarify the meanings intended in this guide by the use of these terms, the following definitions apply:

- **Designer** – HQ Design, Project Development, or Consultant Designer
- **Design Manager** – HQ Design, Project Development, or Consultant Design Manager
- **Design Team** – HQ Design, Project Development, or Consultant Design
- **Technical Report** – Transportation planning reports (i.e. Transportation Investment Reports (TIR), Transportation Planning Report (TPR)) developed by the Strategic Transportation Investments Division.

TDOT ROADWAY DESIGN GUIDELINES
CHAPTER 2 GEOMETRIC DESIGN CRITERIA

English

Revised: 04/24/2023

This page is left blank intentionally.

TDOT ROADWAY DESIGN GUIDELINES
CHAPTER 2 GEOMETRIC DESIGN CRITERIA

English

Revised: 04/24/2023

SECTION 1 – CONTROLLING GEOMETRIC DESIGN CRITERIA

2-100.00 CONTROLLING CRITERIA FOR DESIGN

The following sections define both horizontal and vertical design elements including the 10 controlling criteria for design as defined by the FHWA. The 10 controlling criteria can contribute substantial importance to the operation and safety performance of any highway. A formal written design exception process should be followed if any of the following criteria cannot be met. See [Section 2-105.00 Design Exception Requests](#) for further guidance on the process and required form. The 10 criteria are: Horizontal Curve Radius, Superelevation Rate, Lane Width, Shoulder Width, Cross Slopes, Maximum Grade, Stopping Sight Distance, Design Speed, Vertical Clearance, and Design Loading Structural Capacity.

2-101.00 HORIZONTAL DESIGN

The Horizontal Design consists of the horizontal alignment, typical section, slope development, and roadside design. The horizontal design elements are based off of several factors including design speed, rural or urban setting, type of terrain, AADT, and superelevation. The RD11-TS series - Typical Section and Design Criteria and RD11-SE series - Superelevation Details of the Roadway Standard Drawings shall be used to determine the horizontal curve radius, superelevation, lane width, shoulder width, cross slopes, and side slopes. The proposed design speed and road type are listed in the technical report but shall always be reviewed and compared to the standard drawings to ensure the correct typical section is listed based on road type.

2-101.01 HORIZONTAL CURVE RADIUS AND SUPERELEVATION RATES

Horizontal curves provide transitions between tangent sections of roadway. Refer to RD11-SE series - Superelevation Details of the Roadway Standard Drawings and Minimum Runoff Lengths RD11-LR series of the Roadway Standard Drawings to review requirements for horizontal curve radii based on speed of the road. Designers shall refer to these tables to determine the radius required when designing horizontal alignments. Curve data is generated for each horizontal curve by CADD software programs and shall be shown on all projects. The Designer shall fill in any missing data that is not automatically generated. See Figure 2-1, *Curve Data*.

TDOT ROADWAY DESIGN GUIDELINES
CHAPTER 2 GEOMETRIC DESIGN CRITERIA

English

Revised: 04/24/2023

I-40
CURVE SC10
PI 652+08.49
N 599,076.3989
E 1,514,512.9360
Δ 3° 33' 33" (LT)
D 1° 00' 00"
R 5,729.58
L 355.92
T 178.02
SE 0.036 FT/FT
DESIGN SPEED 70 MPH
TRANS. LENGTH 228

Figure 2-1
Curve Data

Superelevation rates and run-off for horizontal curves are also shown in the RD11-SE series – Superelevation Details of the Roadway Standard Drawings and RD11-LR series - Minimum Runoff Lengths of the Roadway Standard Drawings. For urban projects, the maximum desired superelevation rate is 0.04 ft/ft. For rural projects, the maximum desired superelevation rate is 0.08 ft/ft. If the design superelevation rates cannot be met due to existing conditions, R.O.W. limitations, or other factors, a Design Exception is required. See [Section 2-105.00 Design Exception Requests](#) for further guidance.

The most common type of horizontal curve is a simple circular curve; however, a spiral curve can be used to provide a gradual transition between tangent sections and circular curves. This allows vehicles to more easily transition into and out of a curve while staying within the travel lane. The superelevation tables in the RD11-LR series define when spiral curves shall be placed on projects. Spirals are recommended for curves 50 MPH or greater and superelevation of three percent or greater. In *Table 2-1, Example of Urban Superelevation Table Spiral Curves*, the first entry for a 50 MPH curve that requires a spiral curve is for a Radius of 2,290'.

TDOT ROADWAY DESIGN GUIDELINES
CHAPTER 2 GEOMETRIC DESIGN CRITERIA

English

Revised: 04/24/2023

e d		E MAX = 0.04 DESIRABLE																																																																
		V = 20 (MPH)						V = 25 (MPH)						V = 30 (MPH)						V = 35 (MPH)						V = 40 (MPH)						V = 45 (MPH)						V = 50 (MPH)																												
		R	Number of Lanes					R	Number of Lanes					R	Number of Lanes					R	Number of Lanes					R	Number of Lanes					R	Number of Lanes					R	Number of Lanes																											
(%)	MIN. (FT)	2	3	4	5	6	MIN. (FT)	2	3	4	5	6	MIN. (FT)	2	3	4	5	6	MIN. (FT)	2	3	4	5	6	MIN. (FT)	2	3	4	5	6	MIN. (FT)	2	3	4	5	6	MIN. (FT)	2	3	4	5	6	MIN. (FT)	2	3	4	5	6																		
NC	107	0	0	0	0	0	198	0	0	0	0	0	333	0	0	0	0	0	510	0	0	0	0	0	762	0	0	0	0	0	1039	0	0	0	0	0	1220	0	0	0	0	0	1494	0	0	0	0	0	1720	0	0	0	0	0	1980	0	0	0	0	0						
2	92	32	40	49	57	65	167	34	43	51	60	69	273	36	45	55	64	73	408	39	48	58	68	78	593	41	52	62	72	83	794	44	55	67	78	89	994	48	60	72	84	96	1220	53	66	79	92	106	1494	58	72	86	101	116	1720	62	78	94	109	125	1980	67	84	101	118	135
2.2	91	36	44	54	62	72	165	38	47	57	66	76	270	40	50	60	70	80	404	43	53	64	75	86	586	46	57	68	80	91	785	49	61	73	86	98	994	53	66	79	92	106	1220	58	72	86	101	116	1494	62	78	94	109	125	1720	67	84	101	118	135						
2.4	91	39	48	58	68	78	164	41	51	62	72	83	268	44	54	65	76	88	400	46	58	70	81	93	580	50	62	74	87	100	776	53	66	80	93	107	994	58	72	86	101	116	1220	62	78	94	109	125	1494	67	84	101	118	135												
2.6	90	42	52	63	74	85	163	45	55	67	78	90	265	47	59	71	83	95	396	50	63	75	88	101	573	54	67	81	94	108	767	58	72	87	101	116	994	62	78	94	109	125	1220	67	84	101	118	135																		
2.8	89	45	57	68	79	91	161	48	60	72	84	96	263	51	63	76	89	102	393	54	67	81	95	109	567	58	72	87	101	116	758	62	77	93	109	125	994	67	84	101	118	135																								
3	89	49	61	73	85	98	160	51	64	77	90	103	261	55	68	82	95	110	389	58	72	87	102	117	561	62	77	93	109	125	750	67	83	100	117	134	994	72	90	108	126	145																								
3.2	88	52	65	78	91	104	159	55	68	82	96	110	259	58	72	87	102	117	385	62	77	93	108	124	556	66	82	99	116	133	742	71	89	107	124	143	994	77	96	115	134	154																								
3.4	88	55	69	83	96	111	158	58	73	87	102	117	256	62	77	93	108	124	382	66	82	99	115	132	550	70	88	106	123	141	734	76	94	113	132	152	994	82	102	122	143	164																								
3.6	87	58	73	88	102	117	157	62	77	93	108	124	254	65	81	98	115	132	378	70	87	105	122	140	544	74	93	112	130	150	726	80	100	120	140	161	994	86	108	130	151	174																								
3.8	87	62	77	92	108	124	155	65	81	98	114	131	252	69	86	104	121	139	375	74	92	110	129	148	539	79	98	118	138	158	718	84	105	127	148	170	994	91	114	137	160	183																								
4	86	65	81	97	114	130	154	69	85	103	120	138	250	73	91	109	127	146	371	77	96	116	135	156	533	83	103	124	145	166	711	89	111	133	156	179	926	96	120	144	168	193																								

METHOD 2 ← → METHOD 5
4

Table 2-1
Example of Urban Superelevation Table Spiral Curves

On isolated bridge replacement projects, intersection improvements, widening of existing roadways, etc., where use of spirals would provide no real benefit and/or would be difficult to construct, spirals will not be required. It will still be necessary to provide superelevation and superelevation lengths as shown on RD11-LR series.

2-101.02 TRAVEL, THROUGH, AND TURN LANE WIDTHS

The RD11-TS Series – Typical Sections and Design Criteria Roadway Standard Drawings show the lane width requirement for travel, through, and turn lanes for each road classification. If the lane widths cannot be met due to R.O.W. restrictions, existing conditions, existing structures, etc., a Design Exception Request form shall be submitted. See [Section 2-105.00 Design Exception Requests](#) for further guidance. Design Exceptions are generally not needed at the beginning and ending of a project where lane widths transition down to existing conditions (example twelve feet proposed lanes transition down to existing eleven feet lanes). However, for other roads specified in the Design Exception criteria, the designer shall refer to the typical section standards and evaluate all available information on the road to ensure the best, most economical lane width is proposed. If the Designer has questions or concerns due to the lane width, they should discuss it immediately with the Design Manager and Design Team as well as the Strategic Transportation Investment Division (STID) who furnished the technical report.

2-101.03 SHOULDER WIDTHS

Widths for outside and inside (if applicable) shoulders are defined in each of the RD11-TS Series – Typical Sections and Design Criteria Roadway Standard Drawings based on road classification. If the shoulder width needs to be reduced due to R.O.W. restrictions, existing conditions, existing structures, etc., a Design Exception Request form shall be submitted. See [Section 2-105.00, Design Exception Requests](#), for further guidance.

TDOT ROADWAY DESIGN GUIDELINES
CHAPTER 2 GEOMETRIC DESIGN CRITERIA

English

Revised: 04/24/2023

For lower volume roads, the outside shoulder may be graded only and not paved. For most rural designs, the shoulder will have a greater portion that is paved with a 2' portion that is not. (12' shoulder will have 10' paved; 6' shoulder will have 4' paved; shoulders less than 6' should be fully paved). It is sometimes economical to pave out the additional 2' and this should be discussed at the R.O.W. field review.

When calculating drainage spread, the inside and/or outside shoulder may be used to carry a portion or all of the water. Often, initial drainage calculations include the entire shoulder width plus one-half of a travel lane for spread. On projects where the existing shoulders are used for spread on a closed drainage system, the Designer shall ensure that the reduced shoulder width can still accommodate the flow without increasing the spread more than the amount allowed into the travel lane.

2-101.04 CROSS SLOPES

The cross slopes of travel lanes and shoulders are defined in each of the RD11-TS Series – Typical Sections and Design Criteria Roadway Standard Drawings based on road classification. If the cross slope does not match the standard drawing, a Design Exception Request and Justification form shall be submitted. See [Section 2-105.00 Design Exception Requests](#) for further guidance. The cross slope of a road is normal crown (-0.02 ft/ft) unless it is in a superelevated section. Shoulder cross slopes are usually -0.04 ft/ft. The slopes of the shoulder and roadway pavement shall not exceed an algebraic difference of 0.07 ft/ft.

Designers shall refer to the appropriate RD11-TS Series – Typical Sections and Design Criteria Roadway Standard Drawings to determine what the change in cross slope should be for more than two travel lanes in the same direction. The Designer shall evaluate the drainage for all widening and new alignment projects to ensure the cross slope will drain the road and not cause ponding issues. This is especially critical on interstate widening projects where drainage occurs along a median barrier wall and the existing inside shoulder width may be reduced to accommodate additional lanes.

2-102.00 VERTICAL DESIGN

The Vertical Design consists of the vertical alignment and components of grade, stopping sight distance, passing sight distance, and vertical clearance. The vertical alignment and how it coincides with the horizontal alignment is reflected in the RD11-TS Series-Typical Sections and Design Criteria Roadway Standard Drawings. These standards shall be used to determine maximum grades for specific design speeds and terrain types, minimum stopping sight distance, and minimum passing sight distance.

There are often times when some of the vertical design criteria cannot be met for a portion of the road on a project. A Design Exception shall be requested for the following vertical

TDOT ROADWAY DESIGN GUIDELINES
CHAPTER 2 GEOMETRIC DESIGN CRITERIA

English

Revised: 04/24/2023

components: maximum grade, stopping sight distance, or vertical clearance. See [Section 2-105.00 Design Exception Requests](#) for further guidance.

2-102.01 VERTICAL GRADES

The RD11-TS Series - Typical Sections and Design Criteria Roadway Standard Drawings list the maximum vertical grade based on design speeds and terrain types. If the maximum grade is exceeded, a Design Exception is required. See [Section 2-105.00 Design Exception Requests](#) for further guidance. However, if the grades exceed the maximum recommendations where the Designer is matching existing vertical grade at the beginning and end of the project, a Design Exception is not needed. If there is a question of whether or not a Design Exception is needed, they shall contact the Roadway Design Division at TDOT.Design@tn.gov.

The Designer shall consider constructability of the road, side roads, and private drives when designing the vertical grade. Large cuts and fills are very difficult to construct. If this is unavoidable, the Designer shall discuss traffic control options at the R.O.W. field review.

2-102.02 STOPPING SIGHT DISTANCE

Stopping Sight Distance is the distance that a motorist needs to be able to stop before colliding into something in the road such as another vehicle, pedestrian, debris, etc. Stopping sight distance requirements are incorporated into the RD11-TS Series – Typical Sections and Design Criteria Roadway Standard Drawings. If the criteria for K-values for Stopping Sight Distance are not met, a Design Exception is required. See [Section 2-105.00 Design Exception Requests](#) for further guidance.

2-102.03 STOPPING SIGHT DISTANCE ON HORIZONTAL AND VERTICAL INTERSECTIONS

Designers shall evaluate stopping sight distance and understand the correlation between horizontal and vertical components. Stopping Sight Distance shall be determined for both horizontal and vertical curves at intersections. The Designer shall ensure that intersection sight distance is provided in addition to adequate stopping sight distance at all intersections, railroad crossings without train activated warning devices, and commercial drives. The Designer can calculate the line of sight in these cases. Refer to the RD11-SD Series – Intersection Sight Distance Roadway Standard Drawings- for line of sight calculations and tables.

2-102.04 STOPPING SIGHT DISTANCE ON HORIZONTAL AND VERTICAL CURVES

Sight distance should be determined for both horizontal and vertical curves at intersections. *Figure 2-2, Line of Sight for Stopping Sight Distance for Horizontal Curve*, depicts

TDOT ROADWAY DESIGN GUIDELINES
CHAPTER 2 GEOMETRIC DESIGN CRITERIA

English

Revised: 04/24/2023

a situation where the driver is traveling around a curve and the line of sight needed to ensure the other car is visible. If vegetation or other obstacles were in the designated clear zone area, the motorists would not be able to see the car. Designers shall always evaluate the line of sight for areas such as this and where guardrail, median barrier, retaining walls, vegetation, utility poles, and other roadside elements may cause a sight distance issue which in turn causes a stopping sight distance problem.

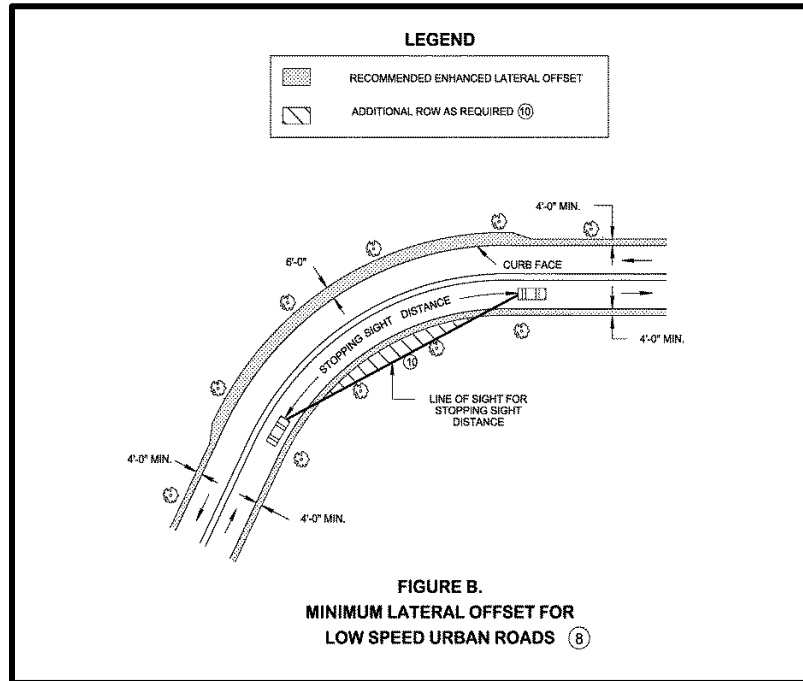

Figure 2-2
Line of Sight for Stopping Sight Distance for Horizontal Curve

Figure 2-3, Line of Sight for Stopping Sight Distance for Vertical Curve, depicts a situation where the driver is traveling over a hill and the road hazard is on the downgrade. Designers shall always evaluate the stopping sight distance on vertical curves where factors such as signalized intersections, side roads, driveway entrances, etc. could cause sight distance issues.

TDOT ROADWAY DESIGN GUIDELINES
CHAPTER 2 GEOMETRIC DESIGN CRITERIA

English

Revised: 04/24/2023

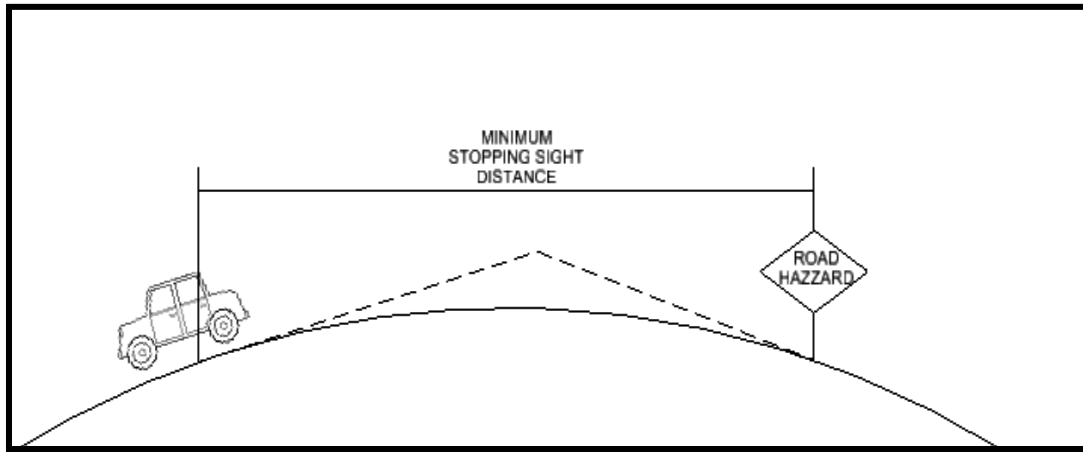

Figure 2-3
Line of Sight for Stopping Sight Distance for Vertical Curve

When designing traffic control plans, stopping sight distance should also be evaluated. When possible, lane drops should be avoided on horizontal and/or vertical curves so that drivers are in a tangent section during the lane drop. Also, designers should ensure that signing is adequate when there are existing stopping sight distance issues or when the construction may be impairing stopping sight distance.

2-102.05 VERTICAL CLEARANCES FOR BRIDGES

The minimum vertical clearance for all structures on all systems shall not be less than 16 feet over the entire roadway width, including the usable width of shoulder. The vertical clearance to sign trusses and pedestrian overpasses shall be 17 feet because of their reduced resistance to impacts. The vertical clearance from the deck to the cross bracing on through truss structures shall also be a minimum of 17 feet. The minimum vertical clearance for railroad crossings from the structure to the top of the rails shall be 23 feet. An allowance of 6 inches shall be added to all vertical clearances to accommodate future resurfacing.

If the length for Stopping Sight Distance is not met, a Design Exception is required. See [Section 2-105.00 Design Exception Requests](#) for further guidance. On crossings of low volume roadways where the cost of providing 16 feet of clearance might be considered unreasonable and may justify an exception, the Design Manager and Structures Division personnel shall complete a joint cost analysis justifying a reduction in vertical clearance. This cost analysis shall be submitted to the Director of the Structures Division for approval.

TDOT ROADWAY DESIGN GUIDELINES
CHAPTER 2 GEOMETRIC DESIGN CRITERIA

English

Revised: 04/24/2023

2-103.00 DESIGN SPEED

The design speed is different from the other controlling criteria in that it is a design control, rather than a specific design element. In other words, the selected design speed establishes the range of design values for many of the other geometric elements of the roadway. Generally, Design Exceptions are requested when the design speed cannot be maintained for the entire project. An example would be that a horizontal or vertical curve could not be designed to meet the proposed design speed. When this occurs, a Design Exception shall be requested for that curve. The project shall be signed with the appropriate advisory speed at locations on the plans where this occurs.

2-104.00 DESIGN LOADING STRUCTURAL CAPACITY

Safe load-carrying capacity for all State unrestricted legal loads or routine permit loads and, in the case of bridges and tunnels on the Interstate, all Federal legal loads is a controlling criteria and shall be evaluated. The Structures Division verifies the loading structural capacity of structures on the roadway. If the proposed design loading structural capacity is not met, a Design Exception shall be requested.

2-105.00 DESIGN EXCEPTION REQUESTS

Despite the range of flexibility that exists with respect to the controlling elements of design, there are situations in which the accepted criteria are not applicable to the project circumstances or cannot reasonably be met. For such instances, when it is appropriate, the [design exception](#) process allows for the use of criteria other than the accepted values. Design exceptions can be viewed as opportunities to add practicality or value to the design and should not necessarily be considered as violation of policy.

The design exception process requires formal approval for exceptions relating to the following 10 controlling criteria of design:

Type I Exception to Controlling Criteria

- Design Speed
- Design Loading Structural Capacity

For exceptions based on Type I Criteria, all roadways on the **NHS** may require FHWA's review. The Roadway Design Division Director provides final approval. Exceptions to Type I criteria are rare and additional information shall be provided.

TDOT ROADWAY DESIGN GUIDELINES
CHAPTER 2 GEOMETRIC DESIGN CRITERIA

English

Revised: 04/24/2023

Type II Exception to Controlling Criteria

- Lane Width
- Horizontal Curve Radius
- Stopping Sight Distance
- Shoulder Width
- Cross Slopes
- Vertical Clearance
- Superelevation Rate
- Maximum Grade

For exceptions based on Type II Criteria, all roadways on the **NHS** with design speeds ≥ 50 mph may require FHWA's review. The Roadway Design Division Director provides final approval.

All other roadways (non-NHS) exceptions to controlling criteria do not require FHWA's review; the Roadway Design Division Director provides final approval.

Projects designated as Limited Scope do not require a design exception.

Note:

Roadways on the Appalachian Development Highway System, or FHWA Projects of Division Interest (PODI) may require FHWA's review for design exceptions regardless of the controlling criteria.

Design exception requests for projects shall be submitted to the Regional Director of Project Development using the Design Exception Form, shown in *Figure 2-4, Design Exception Form*. Once reviewed and recommended for approval, the Regional Director of Project Development shall forward the design exception request form to the Roadway Design Division Director, who will either provide final approval or forward to FHWA for final approval, as appropriate.

Approved design exceptions **shall** be noted, with approval date, in the lower right corner of the title sheet as well as on the cover sheet for the R.O.W. and Construction checklist.

All applicable material from the following list shall be addressed in narrative form on the Design Exception Request Form, shown in *Figure 2-4, Design Exception Form*, by the Designer. For locally developed projects, the highest local official responsible for the project is responsible for this task.

1. Accident experience or data.
2. The effect of the variance from the design standard on safety and operation of the facility.
3. Any safety mitigation measures considered and provided to minimize the effect of the reduced design.
4. The compatibility of the design and operation with adjacent sections.
5. The comparative cost of the full standard versus the reduced design being proposed.
6. The long-term effect of the reduced design as compared to the full standard.

TDOT ROADWAY DESIGN GUIDELINES
CHAPTER 2 GEOMETRIC DESIGN CRITERIA

English

Revised: 04/24/2023

7. The difficulty in obtaining the full standard such as right-of-way restriction, delays, environmental impacts, etc.
8. Any capacity reductions or operational problems caused by the proposed exception.
9. Level of service for full standards versus the reduced design.
10. The cumulative effect of more than one standard that is being reduced.
11. The possibility of improving or correcting the reduced design feature in the future.

TDOT ROADWAY DESIGN GUIDELINES
CHAPTER 2 GEOMETRIC DESIGN CRITERIA

English

Revised: 04/24/2023

DESIGN EXCEPTION REQUEST FORM



TO: Choose One

FROM: Choose One

DATE: [Click here to enter a date.](#)

This form is to be used on projects requesting a Design Exception where roadway projects do not meet the 10 controlling elements of the geometric design criteria.

Design Exception:

Type I Exception to Controlling Criteria

- Design Speed
- Design Loading Structural Capacity

For exceptions based on Type I Criteria, all roadways on the **NHS** may require FHWA's review. The Roadway Design Division Director provides final approval. Exceptions to Type I criteria are rare and additional information shall be provided.

Type II Exception to Controlling Criteria

• Lane Width	• Cross Slopes
• Horizontal Curve Radius	• Vertical Clearance
• Stopping Sight Distance	• Superelevation Rate
• Shoulder Width	• Maximum Grade

For exceptions based on Type II Criteria, all roadways on the **NHS** with design speeds \geq 50 mph may require FHWA's review. The Roadway Design Division Director provides final approval.

All other roadways (non-NHS) exceptions to controlling criteria do not require FHWA's review; the Roadway Design Division Director provides final approval.

Note:
Roadways on the Appalachian Development Highway System, or FHWA Projects of Division Interest (PODI) may require FHWA's review for design exceptions regardless of the controlling criteria.

DOCUMENTATION

A design **exception** is a variance based on one or more of the controlling criteria (either Type I or Type II). **All requests shall be documented on this form.** Plan sheets, location map, and supplemental information (i.e. Google maps) must be enclosed for a timely review by the Department. All design exception requests must be justified based on the objective and context demonstrating compliance with accepted transportation engineering principles and reasons for the decisions. The proposed variation shall not

Page 1 of 7

02/11/20

Figure 2-4
Design Exception Request Form

TDOT ROADWAY DESIGN GUIDELINES
CHAPTER 2 GEOMETRIC DESIGN CRITERIA

English

Revised: 04/24/2023

diminish the existing operation and safety of the facility. Historical in-service performance or a traffic engineering study (on site or simulation) may be required.

Type I Exception to Controlling Criteria requires additional documentation:

- Design Speed exceptions. Length of section with reduced design speed compared to overall length of project. Measures used in transitions to adjacent sections with higher or lower design or operating speeds.
- Design Loading Structural Capacity exceptions. Verification of safe load-carrying capacity (load rating) for all State unrestricted legal loads or routine permit loads, and in the case of bridges and tunnels on the Interstate, all Federal legal loads.

Type II Exception to Controlling Criteria requires additional documentation:

- Specific design criteria that will not be met.
- Existing roadway characteristics.
- Alternatives considered.
- Comparison of the safety and operational performance of the roadway and other impacts such as right-of-way, community, environmental, cost, and usability by all modes of transportation.
- Proposed mitigation measures.
- Compatibility with adjacent sections of roadway.

Additional guidance can be found in the Highway Capacity Manual, Highway Safety Manual, Performance Based Practical Design, and Flexibility in Design. Design Exception Requests located within the city limits require a letter from the local agency approving the request.

All other geometric design variances on facilities outside the category I and II criteria shall be documented on a Design Waiver Request form.

Figure 2-4 (Continued)
Design Exception Request Form

TDOT ROADWAY DESIGN GUIDELINES
CHAPTER 2 GEOMETRIC DESIGN CRITERIA

English

Revised: 04/24/2023

PROJECT DATA	
Current Project Phase	Planning <input type="checkbox"/> Design <input type="checkbox"/> Construction <input type="checkbox"/> Scope change <input type="checkbox"/> (Evaluate NEPA impact)
County/ City	
PIN	
Federal Project No.	
State Project No.	
Project Limits	
Local Program Project	Yes <input type="checkbox"/> No <input type="checkbox"/> If yes, then
State Let	Yes <input type="checkbox"/> No <input type="checkbox"/>
Local Let	Yes <input type="checkbox"/> No <input type="checkbox"/>
Project Type	New Alignment <input type="checkbox"/> Reconstruction <input type="checkbox"/> Resurfacing <input type="checkbox"/> Road Diet/Road Reconfiguration <input type="checkbox"/> (Note: Road Diet Evaluation form may be required) Maintenance <input type="checkbox"/> Road Safety Audit <input type="checkbox"/> Bridge Repair <input type="checkbox"/> Bridge Rehabilitation <input type="checkbox"/> Signalization <input type="checkbox"/> Other <input type="checkbox"/>
US Route/NHS	Yes <input type="checkbox"/> No <input type="checkbox"/>
State Route	Yes <input type="checkbox"/> No <input type="checkbox"/>
Appalachian Development Highway System	Yes <input type="checkbox"/> No <input type="checkbox"/>
FHWA PODI Project	Yes <input type="checkbox"/> No <input type="checkbox"/>
Project Scope (Briefly describe the objective of project)	
Project Commitments	

Figure 2-4 (Continued)
Design Exception Request Form

TDOT ROADWAY DESIGN GUIDELINES
CHAPTER 2 GEOMETRIC DESIGN CRITERIA

English

Revised: 04/24/2023

ROADWAY GEOMETRIC DESIGN DATA	
Highway Functional Classification: (See Green Book 2011 Section 1.3)	Freeway <input type="checkbox"/> Arterial <input type="checkbox"/> Collector <input type="checkbox"/> Local Road/Street <input type="checkbox"/>
Rural or Urban Context	Rural <input type="checkbox"/> Rural Town (city limits) <input type="checkbox"/> Suburban (initially designed as rural but currently in city limits) <input type="checkbox"/> Urban (city limits) <input type="checkbox"/> Urban Core (in the metropolitan government jurisdiction) <input type="checkbox"/>
Roadway Typical Section Standard Drawing:	_____
Existing Design Speed:	_____ <small>Contact the Plans Sales Office to find original plans stating the design speed or use existing design elements to reverse engineer the design speed.</small>
Existing Posted Speed:	_____
Proposed Design Speed:	_____
Proposed Posted Speed:	_____
Type of Terrain:	Level <input type="checkbox"/> Rolling <input type="checkbox"/> Mountainous <input type="checkbox"/>
Traffic Data:	ADT (20XX): _____ D: <u> / </u> ADT (20XX): _____ T: _____ % DHV: _____
Access Control	None <input type="checkbox"/> Partial <input type="checkbox"/> Full <input type="checkbox"/>
Multimodal Design Elements Included in the scope of the Project	Pedestrian <input type="checkbox"/> Curb Ramps <input type="checkbox"/> Pedestrian Signals <input type="checkbox"/> Shared-Use Path <input type="checkbox"/> New sidewalks <input type="checkbox"/> Non-motorized Enhancement <input type="checkbox"/> Bicycle <input type="checkbox"/> (including bike route/lane, tract addition to existing roadway facility)
Bus Route	Yes <input type="checkbox"/> No <input type="checkbox"/>

Figure 2-4 (Continued)
Design Exception Request Form

TDOT ROADWAY DESIGN GUIDELINES
CHAPTER 2 GEOMETRIC DESIGN CRITERIA

English

Revised: 04/24/2023

GEOMETRIC DESIGN CONTROLLING CRITERIA Design Exception Requests			
Controlling elements must be completed for items where an exception is requested.			
	Existing	Proposed	Exception
Design Speed:			
Design Loading structural capacity:			
Lane width:			
Shoulder width (inside/outside):			
Cross Slope:			
Superelevation Rate:			
Horizontal Curve Radius:			
Stopping Sight Distance:			
Maximum Grade:			
Vertical Clearance:			
Navigational			
Waterway:			
Grade separation:			
Railroad crossing:			

BRIDGE DESIGN FEATURES				
Complete if the bridge feature values differ from those listed in the Geometric Design Controlling Criteria Section.				
	Existing	Proposed	Exception	REQ
Traffic Lane Widths:				<input type="checkbox"/>
Outside Shoulder Widths:				<input type="checkbox"/>
Inside Shoulder Widths:				<input type="checkbox"/>
Sufficiency Rating:				<input type="checkbox"/>

CRASH HISTORY SUMMARY REPORT			
Years Reviewed	Total Crashes	Fatal Crashes	Injury Crashes

TDOT DIRECTIVES TO BE CONSIDERED FOR THE EXCEPTION REQUEST			
	YES	NO	N/A
SAFETY			
Crash history data has been reviewed and is enclosed.	<input type="checkbox"/>	<input type="checkbox"/>	<input type="checkbox"/>
All roadway and roadside safety mitigation measures have been considered and provided.	<input type="checkbox"/>	<input type="checkbox"/>	<input type="checkbox"/>
The proposed variance from the minimum roadway design standards does not adversely affect the safety of the facility.	<input type="checkbox"/>	<input type="checkbox"/>	<input type="checkbox"/>
The Highway Safety Manual was used to justify the design exception.	<input type="checkbox"/>	<input type="checkbox"/>	<input type="checkbox"/>
OPERATIONS			

Figure 2-4 (Continued)
Design Exception Request Form

TDOT ROADWAY DESIGN GUIDELINES
CHAPTER 2 GEOMETRIC DESIGN CRITERIA

English

Revised: 04/24/2023

The operation of the proposed typical cross-section is comparable with operation of the adjacent cross-sections.	<input type="checkbox"/>	<input type="checkbox"/>	<input type="checkbox"/>
The proposed design does not cause a reduction in capacity or adversely affect traffic flow of the facility.	<input type="checkbox"/>	<input type="checkbox"/>	<input type="checkbox"/>
The proposed design does not adversely affect long-term operations.	<input type="checkbox"/>	<input type="checkbox"/>	<input type="checkbox"/>
The proposed design does not impact the existing access control.	<input type="checkbox"/>	<input type="checkbox"/>	<input type="checkbox"/>
Travel demand management solutions have been evaluated.	<input type="checkbox"/>	<input type="checkbox"/>	<input type="checkbox"/>
ROADWAY DESIGN			
It is not feasible to meet the minimum roadway design standards due to right-of-way restrictions, environmental impacts, etc.	<input type="checkbox"/>	<input type="checkbox"/>	<input type="checkbox"/>
The proposed design maintains the same level of service compared to the design based on minimum roadway design standards.	<input type="checkbox"/>	<input type="checkbox"/>	<input type="checkbox"/>
The proposed design results in a significant cost savings compared to the design based on minimum roadway design standards.	<input type="checkbox"/>	<input type="checkbox"/>	<input type="checkbox"/>
ENVIRONMENTAL (Consult TDOT Environmental Division, if needed)			
Does the request affect the NEPA environmental boundary?	<input type="checkbox"/>	<input type="checkbox"/>	<input type="checkbox"/>
Does the request affect environmental permit requirements? (TDEC/TVA/CORPs/TWRA, etc.)	<input type="checkbox"/>	<input type="checkbox"/>	<input type="checkbox"/>
Does the request affect Historical Section 106?	<input type="checkbox"/>	<input type="checkbox"/>	<input type="checkbox"/>
WORK ZONE			
Will the proposed variation affect the TMP?	<input type="checkbox"/>	<input type="checkbox"/>	<input type="checkbox"/>

DESCRIBE THE REASONING AND JUSTIFICATION OF THE DESIGN EXCEPTION REQUEST:
 (Address project needs, with consideration of all transportation modes, community engagement, safety, and with consistency towards long term planning and vision. Provide an explanation of the requested design exception and describe other nationally recognized guidance that is met and that the design is based upon. Attach documentation of the specific design guidance met.)

DESIGN EXCEPTION REQUEST – JUSTIFIED BASED ON GUIDANCE FROM THE FOLLOWING:					
Design Guidance Source	Design Guidance Met				Source Reference if answered "Yes" (page, section, drawing, etc.)
	YES	NO	N/A	Do Not Know	
AASHTO Publication	<input type="checkbox"/>	<input type="checkbox"/>	<input type="checkbox"/>	<input type="checkbox"/>	
Highway Safety Manual	<input type="checkbox"/>	<input type="checkbox"/>	<input type="checkbox"/>	<input type="checkbox"/>	
Highway Capacity Manual	<input type="checkbox"/>	<input type="checkbox"/>	<input type="checkbox"/>	<input type="checkbox"/>	
FHWA Publication	<input type="checkbox"/>	<input type="checkbox"/>	<input type="checkbox"/>	<input type="checkbox"/>	
NCHRP Publication	<input type="checkbox"/>	<input type="checkbox"/>	<input type="checkbox"/>	<input type="checkbox"/>	
TRB Publication	<input type="checkbox"/>	<input type="checkbox"/>	<input type="checkbox"/>	<input type="checkbox"/>	
TDOT Design Guidelines	<input type="checkbox"/>	<input type="checkbox"/>	<input type="checkbox"/>	<input type="checkbox"/>	
TDOT Standard Drawings	<input type="checkbox"/>	<input type="checkbox"/>	<input type="checkbox"/>	<input type="checkbox"/>	
Guidance from other states	<input type="checkbox"/>	<input type="checkbox"/>	<input type="checkbox"/>	<input type="checkbox"/>	
Other					

Page 6 of 7

02/11/20

Figure 2-4 (Continued)
Design Exception Request Form

TDOT ROADWAY DESIGN GUIDELINES
CHAPTER 2 GEOMETRIC DESIGN CRITERIA

English

Revised: 04/24/2023

DESCRIBE THE ALTERNATIVES CONSIDERED
(Provide an explanation of proposed mitigation measures to offset impact such as cost, ROW, environmental, multimodal, safety and operation, community and usability, or compatibility with adjacent section of the roadway)

DESIGN EXCEPTION IS REVIEWED AND RECOMMENDED FOR APPROVAL BY:

_____ Click here to enter a date.
Regional Project Development Director Date

DESIGN EXCEPTION APPROVED BY:

_____ Click here to enter a date.
Roadway Design Division Director Date

Reviewer Comments Attached
 Additional Design Exception Information Attached

Page 7 of 7

02/11/20

Figure 2-4 (Continued)
Design Exception Request Form

TDOT ROADWAY DESIGN GUIDELINES
CHAPTER 2 GEOMETRIC DESIGN CRITERIA

English

Revised: 04/24/2023

SECTION 2 – NON-CONTROLLING GEOMETRIC DESIGN CRITERIA

2-200.00 NON-CONTROLLING GEOMETRIC DESIGN CRITERIA

In addition to the 10 controlling criteria designated by FHWA, there are other criteria that are critical to the geometric design. Any deviation from the standards for these design elements will require a [Design Waiver](#) as opposed to a Design Exception.

2-200.01 PASSING SIGHT DISTANCE

Passing sight distance requirements are incorporated into the RD11-TS Series – Typical Sections and Design Criteria Roadway Standard Drawings. Sufficient passing sight distance is a major factor when designing a two-lane road. The Designer shall ensure both the horizontal and vertical design is sufficient to provide passing zones. The motorist needs vertical sight distance as well as horizontal passing zone length. Refer to *A Policy on Geometric Design of Highways and Streets*, AASHTO, 2011, Chapter 3.

2-200.02 VERTICAL CURVES

A vertical curve provides a transition between two different roadway profile grades, allowing the vehicle to negotiate the elevation rate change at a gradual rate rather than a sharp angle (see *Figure 2-5, Vertical Curves*). The design of the curve is dependent on the intended design speed for the roadway, as well as drainage, slope acceptable rate of change, and friction. Refer to *A Policy on Geometric Design of Highways and Streets*, AASHTO, 2011, Chapter 3. Proper design of vertical curves helps minimize and balance cut and fill; provides sufficient sight distance; and maintains adequate drainage. See the Roadway Design Typical Section and Design Criteria standard drawings for maximum grades, minimum stopping sight distances, design stopping sight distances, and minimum “K” values for crest, sag and passing sight distance for crest curves.

TDOT ROADWAY DESIGN GUIDELINES
CHAPTER 2 GEOMETRIC DESIGN CRITERIA

English

Revised: 04/24/2023

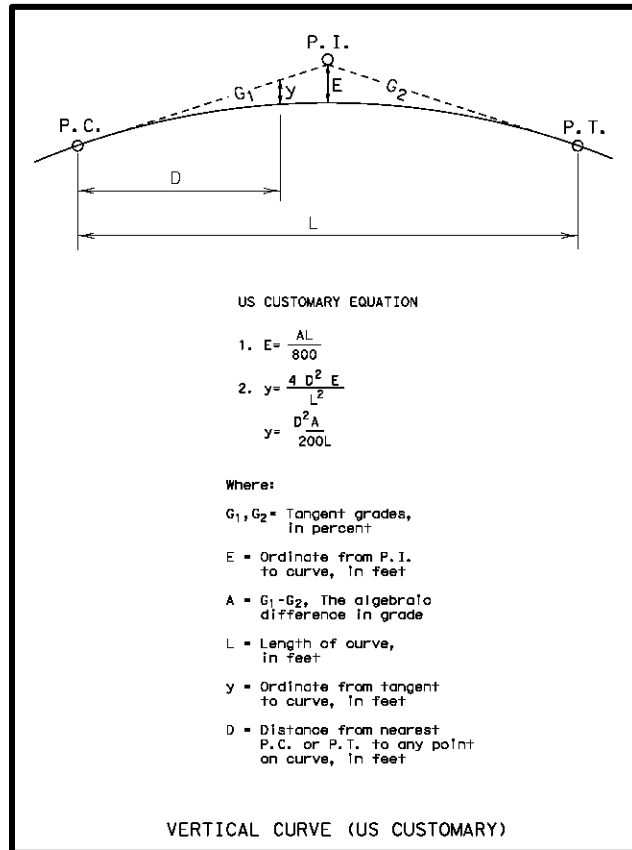

Figure 2-5
Vertical Curves

2-200.03 ROADSIDE SLOPE DEVELOPMENT

As discussed in Section 4-201.02, Soils and Geology, Designers shall request a Soils and Geotechnical analysis in the Initial Studies request. Information from this report will provide the Designer with alternate slopes that may be needed that differ from the Standard Drawings and/or information on other measures that may be needed for slope stabilization, such as the addition of a rock pad, rock buttress, etc.

Roadside slopes are generally classified as a recoverable, traversable, non-traversable or critical slope.

- Traversable slopes consist of a slope that is 3:1 or flatter and free of obstructions in the clear zone.
- Recoverable slopes consist of a slope that is 4:1 or flatter and free of obstructions in the clear zone.

TDOT ROADWAY DESIGN GUIDELINES
CHAPTER 2 GEOMETRIC DESIGN CRITERIA

English

Revised: 04/24/2023

- Non-traversable slopes are either steeper than 3:1 or have obstructions in the clear zone.
- Critical slopes consist of a slope that is non-traversable and shall be protected by guardrail, retaining wall, barrier rail, cable barrier, etc.

2-200.04 CLEAR ZONE

Clear zone is the unobstructed traversable portion of the roadside that allows a driver who has lost control of their vehicle to re-gain control and stop safely. Clear zone criteria are defined in the S-CZ Series – Clear Zone and Safety Plans Roadway Standard Drawings. If at all possible, nothing shall be located within this area. However, the standard drawings take the Designer through the steps to determine what to do to a hazard that is located in the clear zone. Options are removal, relocation, making the obstacle breakaway, shielding with barrier, or delineating the object. Designers often miss obvious roadside hazards such as endwalls, interstate sign poles located in medians, etc. Rigid roadside features such as abutments or bridge parapets shall be placed such that a minimum 24' clear path (both travel lanes + shoulder) is provided for large farm equipment on rural roadways. Refer to the *Roadside Design Guide*, AASHTO, current version, for further information for clear zone areas.

CLEAR ZONES IN URBAN AREAS BEHIND CURB AND GUTTERS

In rural areas, the typical sections for clear zones are easily defined based on the typical sections and distance between the edge of pavement line and ditch. Clear zones in urban areas are usually harder to determine because of the numerous factors such as whether a grass strip is located between the back of curb and the sidewalk or if the sidewalk is a larger shared-use path, etc. The S-CZ Series (Clear Zone and Safety Plans) and MM-SW-1 Roadway Standard Drawings clearly define what the clear zone is in several situations. The Designer shall ensure that ADA accessibility requirements are met if a pole must be placed in a sidewalk area because there are no other options. In this case, there has to be a minimum of four feet (4') clearance from the hazard to the edge of the sidewalk (See MM-SW-1 for more information). This shall be discussed at the R.O.W. field review with all utilities that are located within the project as well as the Traffic Operations Division if signals and/or lighting are proposed on the project.

CLEAR ZONES ON CURVED ALIGNMENTS

Designers shall evaluate the clear zone on curves. In Chapter 3 of the AASHTO *Roadside Design Guide*, a formula is given for an increase in clear zone on the outside of curves. The clear zone on a curved alignment is determined by increasing the value obtained from the *Roadside Design Guide* method for a tangent section of highway. The tangent section clear zone is increased by a curve correction factor, which is based on the degree of curvature and the design speed. No obstacles shall be located within the line of sight around the curve. It may be that additional R.O.W. is purchased to ensure that this criterion is met.

TDOT ROADWAY DESIGN GUIDELINES
CHAPTER 2 GEOMETRIC DESIGN CRITERIA

English

Revised: 04/24/2023

TABLE A. CLEAR ZONE DISTANCE (L _c) (FEET)							
DESIGN SPEED	DESIGN ADT	FORESLOPES (H:V)			BACKSLOPES (H:V)		
		6:1 OR FLATTER	5:1 TO 4:1	3:1	6:1 OR FLATTER	5:1 TO 4:1	3:1
40 MPH OR LESS	UNDER 750 (7)	7 - 10	7 - 10	(4)	7 - 10	7 - 10	7 - 10
	750 - 1500	10 - 12	12 - 14	(4)	12 - 14	12 - 14	12 - 14
	1500 - 6000	12 - 14	14 - 16	(4)	14 - 16	14 - 16	14 - 16
	OVER 6000	14 - 16	16 - 18	(4)	16 - 18	16 - 18	16 - 18
45-50 MPH	UNDER 750 (7)	10 - 12	12 - 14	(4)	10 - 12	8 - 10	8 - 10
	750 - 1500	14 - 16	16 - 20	(4)	14 - 16	12 - 14	10 - 12
	1500 - 6000	16 - 18	20 - 26	(4)	16 - 18	14 - 16	12 - 14
	OVER 6000	20 - 22	24 - 28	(4)	20 - 22	18 - 20	14 - 16
55 MPH	UNDER 750 (7)	12 - 14	14 - 18	(4)	10 - 12	10 - 12	8 - 10
	750 - 1500	16 - 18	20 - 24	(4)	16 - 18	14 - 16	10 - 12
	1500 - 6000	20 - 22	24 - 30	(4)	20 - 22	16 - 18	14 - 16
	OVER 6000	22 - 24	26 - 32 (3)	(4)	22 - 24	20 - 22	16 - 18
60 MPH	UNDER 750 (7)	16 - 18	(9)	(9)	14 - 16	12 - 14	10 - 12
	750 - 1500	20 - 24	(9)	(9)	20 - 22	16 - 18	12 - 14
	1500 - 6000	26 - 30	(9)	(9)	24 - 26	18 - 22	14 - 18
	OVER 6000	30 - 32 (3)	(9)	(9)	26 - 28	24 - 26	20 - 22
65-70 MPH	UNDER 750 (7)	18 - 20	(9)	(9)	14 - 16	14 - 16	10 - 12
	750 - 1500	24 - 26	(9)	(9)	20 - 22	18 - 20	12 - 16
	1500 - 6000	28 - 32 (3)	(9)	(9)	26 - 28	22 - 24	16 - 20
	OVER 6000	30 - 34 (3)	(9)	(9)	28 - 30	26 - 30	22 - 24

ADAPTED FROM TABLE 3.1 OF THE "ROADSIDE DESIGN GUIDE," AASHTO, 2011.

Figure 2-6
Clear Zone Distance (L_c)

The Designer must remember that the clear zone values (L_c), *Figure 2-6, Clear Zone Distance (L_c)*, are based on a constant side slope throughout the clear zone distance. In situations where the side slope changes within the calculated clear zone, the clear zone must be recalculated based on a weighted average of the side slopes.

2-200.05 DESIGN VEHICLE

Designers should consider the largest design vehicle that is likely to frequently use the road to determine the design vehicle. For urban areas, public transportation vehicles (CITY-BUS) shall be the design vehicle. For rural and suburban areas, a large school bus (S-BUS40) shall be the design vehicle. If the traffic report indicates 2% or more truck traffic, then a semi-truck (WB-67) size shall be evaluated for both rural and urban areas. Design vehicles should be carefully considered anywhere they are expected to make a turning movement through an intersection. For more information on design vehicles, see the AASHTO Green Book and Roadway Standard RD11-SD series. If the project design is unable to meet these design vehicles, a design waiver form should be submitted.

TDOT ROADWAY DESIGN GUIDELINES
CHAPTER 2 GEOMETRIC DESIGN CRITERIA

English

Revised: 04/24/2023

2-200.06 MULTIMODAL FACILITIES

The Designer shall refer to Chapter 3, Multimodal Design, for guidance on bicycle lanes. The MM-TS Series – Typical Sections and Design Criteria of the Roadway Standard Drawings provides width requirements for bicycle and pedestrian facilities for several applications.

2-201.00 DESIGN WAIVER REQUESTS

A Design Waiver is a variance not based on the 10 controlling design criteria. It is any variance from the TDOT Standard Drawings. These requests include, but are not limited to, clear zone width, passing sight distance, vertical curves, and multimodal features. A Design Waiver Request Form, see *Figure 2-7, Design Waiver Form*, shall be submitted for approval by the Regional Project Development Director and then approved by the Roadway Design Director (or Designee).

Approved design waivers **shall** be noted, with approval date, in the lower right corner of the title sheet as well as on the cover sheet for the R.O.W. and Construction checklist. Justification shall be provided on the Design Waiver Request Form.

TDOT ROADWAY DESIGN GUIDELINES
CHAPTER 2 GEOMETRIC DESIGN CRITERIA

English

Revised: 04/24/2023

DESIGN WAIVER REQUEST FORM



TO: Choose One

FROM: Choose One

DATE: [Click here to enter a date.](#)

This form is to be used on projects requesting a Design Waiver to non-controlling elements of design on any roadway project.

Design Waiver:

For non-controlling element deviations, a Design Waiver Request must be completed. These requests do not require FHWA's approval; the Roadway Design Division Director provides final approval. These requests include, but are not limited to, clear zone width, passing sight distance, vertical curves, and multimodal features.

DOCUMENTATION

Design Waivers to non-controlling criteria

A design *waiver* is a variance based on non-controlling criteria. All requests shall be documented on this form. Plan sheets, location map, and supplemental information (i.e. google maps) must be enclosed for a timely review by the Department. All design waivers must be justified based on the objective and context demonstrating compliance with accepted transportation engineering principles and reasons for the decisions. The proposed variation shall not diminish the existing operation and safety of the facility. Historical in-service performance or a traffic engineering study (on site or simulation) may be required.

Waivers to Non-Controlling Criteria typically require further evaluation of the design elements to support the request such as,

- Current design criteria that could not be met.
- Existing roadway characteristics.
- Alternatives considered.
- Comparison of the safety and operational performance of the roadway and other impacts such as right-of-way, community, environmental, cost, and usability by all modes of transportation.
- Proposed mitigation measures.
- Compatibility with adjacent sections of roadway.

Additional guidance can be found in the Highway Capacity Manual, Highway Safety Manual, Performance Based Practical Design, and Flexibility in Design. Design Waiver Requests located within the city limits require a letter from the local agency approving the request.

Page 1 of 6

02/11/20

Figure 2-7
Design Waiver Request Form

TDOT ROADWAY DESIGN GUIDELINES
CHAPTER 2 GEOMETRIC DESIGN CRITERIA

English

Revised: 04/24/2023

PROJECT DATA	
Current Project Phase	Planning <input type="checkbox"/> Design <input type="checkbox"/> Construction <input type="checkbox"/> Scope change <input type="checkbox"/> (Evaluate NEPA impact)
County/ City	
PIN	
Federal Project No.	
State Project No.	
Project Limits	
Local Program Project	Yes <input type="checkbox"/> No <input type="checkbox"/> If yes, then
State Let	Yes <input type="checkbox"/> No <input type="checkbox"/>
Local Let	Yes <input type="checkbox"/> No <input type="checkbox"/>
Project Type	New Alignment <input type="checkbox"/> Reconstruction <input type="checkbox"/> Resurfacing <input type="checkbox"/> Road Diet/Road Reconfiguration <input type="checkbox"/> (Note: Road Diet Evaluation form may be required) Maintenance <input type="checkbox"/> Road Safety Audit <input type="checkbox"/> Bridge Repair <input type="checkbox"/> Bridge Rehabilitation <input type="checkbox"/> Signilization <input type="checkbox"/> Other <input type="checkbox"/>
US Route/NHS	Yes <input type="checkbox"/> No <input type="checkbox"/>
State Route	Yes <input type="checkbox"/> No <input type="checkbox"/>
Appalachian Development Highway System	Yes <input type="checkbox"/> No <input type="checkbox"/>
FHWA PODI Project	Yes <input type="checkbox"/> No <input type="checkbox"/>
Project Scope (Briefly describe the objective of project)	
Project Commitments	

Figure 2-7 (Continued)
Design Waiver Request Form

TDOT ROADWAY DESIGN GUIDELINES
CHAPTER 2 GEOMETRIC DESIGN CRITERIA

English

Revised: 04/24/2023

ROADWAY GEOMETRIC DESIGN DATA	
Highway Functional Classification: <small>(See Green Book 2011 Section 1.3)</small>	Freeway <input type="checkbox"/> Arterial <input type="checkbox"/> Collector <input type="checkbox"/> Local Road/Street <input type="checkbox"/>
Rural or Urban Context	Rural <input type="checkbox"/> Rural Town (city limits) <input type="checkbox"/> Suburban (initially designed as rural but currently in city limits) <input type="checkbox"/> Urban (city limits) <input type="checkbox"/> Urban Core (in the metropolitan government jurisdiction) <input type="checkbox"/>
Roadway Typical Section Standard Drawing:	_____
Existing Design Speed:	_____
Existing Posted Speed:	_____ <small>Contact the Plans Sales Office to find original plans stating the design speed or use existing design elements to reverse engineer the design speed.</small>
Proposed Design Speed:	_____
Proposed Posted Speed:	_____
Type of Terrain:	Level <input type="checkbox"/> Rolling <input type="checkbox"/> Mountainous <input type="checkbox"/>
Traffic Data:	ADT (20XX): _____ D: <u> </u> / <u> </u> ADT (20XX): _____ T: _____ % DHV: _____
Access Control	None <input type="checkbox"/> Partial <input type="checkbox"/> Full <input type="checkbox"/>
Multimodal Design Elements Included in the scope of the Project	Pedestrian <input type="checkbox"/> Pedestrian Signals <input type="checkbox"/> Curb Ramps <input type="checkbox"/> Shared-Use Paths <input type="checkbox"/> New sidewalks <input type="checkbox"/> Non-motorized Enhancement <input type="checkbox"/> Bicycle <input type="checkbox"/> (including bike route/lane, tract addition to existing roadway facility)
Bus Route	Yes <input type="checkbox"/> No <input type="checkbox"/>

Figure 2-7 (Continued)
Design Waiver Request Form

TDOT ROADWAY DESIGN GUIDELINES
CHAPTER 2 GEOMETRIC DESIGN CRITERIA

English

Revised: 04/24/2023

GEOMETRIC DESIGN NON-CONTROLLING ELEMENT CRITERIA			
All applicable non-controlling elements must be completed for Design Waiver requests			
	Existing	Proposed	Waiver
Passing Sight Distance: Crest/Sag Vertical Curve: Design vehicle: Clear Zone width: Other:			

MULTIMODAL FEATURES			
	Existing	Proposed	Waiver
Facility Type: Roadway <input type="checkbox"/> Pedestrian <input type="checkbox"/> Bicycle <input type="checkbox"/> Shared-Use <input type="checkbox"/> Curb Shape: Curb Ramp: Sidewalk: Shared-use Path: Mid-block Crossing: RRFB or HAWK: Bike Lane: Bike Lane Buffer: Bike Route: Bike Lane at Intersection: Cycle Track: Transit Facility/Stop Other:			

CRASH HISTORY			
Years Reviewed	Total Crashes	Fatal Crashes	Injury Crashes

TDOT DIRECTIVES TO BE CONSIDERED FOR THE WAIVER REQUEST			
	YES	NO	N/A
SAFETY			
Crash history data has been reviewed and is enclosed.	<input type="checkbox"/>	<input type="checkbox"/>	<input type="checkbox"/>
All roadway and roadside safety mitigation measures have been considered and provided.	<input type="checkbox"/>	<input type="checkbox"/>	<input type="checkbox"/>
The proposed variance from the minimum roadway design standards does not adversely affect the safety of the facility.	<input type="checkbox"/>	<input type="checkbox"/>	<input type="checkbox"/>
The Highway Safety Manual was used to justify the Design Waiver.	<input type="checkbox"/>	<input type="checkbox"/>	<input type="checkbox"/>
OPERATIONS			
The operation of the proposed typical cross-section is comparable with operation of the adjacent cross-sections.	<input type="checkbox"/>	<input type="checkbox"/>	<input type="checkbox"/>

Page 4 of 6

02/11/20

Figure 2-7 (Continued)
Design Waiver Request Form

TDOT ROADWAY DESIGN GUIDELINES
CHAPTER 2 GEOMETRIC DESIGN CRITERIA

English

Revised: 04/24/2023

The proposed design does not cause a reduction in capacity or adversely affect traffic flow of the facility.	<input type="checkbox"/>	<input type="checkbox"/>	<input type="checkbox"/>
The proposed design does not adversely affect long-term operations.	<input type="checkbox"/>	<input type="checkbox"/>	<input type="checkbox"/>
The proposed design does not impact the existing access control.	<input type="checkbox"/>	<input type="checkbox"/>	<input type="checkbox"/>
Travel demand management solutions have been evaluated.	<input type="checkbox"/>	<input type="checkbox"/>	<input type="checkbox"/>
ROADWAY DESIGN			
It is not feasible to meet the minimum roadway design standards due to right-of-way restrictions, environmental impacts, etc.	<input type="checkbox"/>	<input type="checkbox"/>	<input type="checkbox"/>
The proposed design maintains the same level of service compared to the design based on minimum roadway design standards.	<input type="checkbox"/>	<input type="checkbox"/>	<input type="checkbox"/>
The proposed design results in a significant cost savings compared to the design based on minimum roadway design standards.	<input type="checkbox"/>	<input type="checkbox"/>	<input type="checkbox"/>
ENVIRONMENTAL (Consult TDOT Environmental Division, if needed)			
Does the request affect environmental permit requirements? (TDEC/TVA/CORPs/TWRA, etc.)	<input type="checkbox"/>	<input type="checkbox"/>	<input type="checkbox"/>
Does the request affect NEPA environmental boundary?	<input type="checkbox"/>	<input type="checkbox"/>	<input type="checkbox"/>
Does the request affect Historical Section 106 area?	<input type="checkbox"/>	<input type="checkbox"/>	<input type="checkbox"/>
WORK ZONE			
Will the proposed variation affect the TMP?	<input type="checkbox"/>	<input type="checkbox"/>	<input type="checkbox"/>

DESIGN WAIVER REQUEST – JUSTIFIED BASED ON GUIDANCE FROM THE FOLLOWING:					
Design Guidance Source	Design Guidance Met				Source Reference if answered "Yes" (page, section, drawing, etc.)
	YES	NO	N/A	Do Not Know	
AASHTO Publication	<input type="checkbox"/>	<input type="checkbox"/>	<input type="checkbox"/>	<input type="checkbox"/>	
Highway Safety Manual	<input type="checkbox"/>	<input type="checkbox"/>	<input type="checkbox"/>	<input type="checkbox"/>	
Highway Capacity Manual	<input type="checkbox"/>	<input type="checkbox"/>	<input type="checkbox"/>	<input type="checkbox"/>	
FHWA Publication	<input type="checkbox"/>	<input type="checkbox"/>	<input type="checkbox"/>	<input type="checkbox"/>	
NCHRP Publication	<input type="checkbox"/>	<input type="checkbox"/>	<input type="checkbox"/>	<input type="checkbox"/>	
TRB Publication	<input type="checkbox"/>	<input type="checkbox"/>	<input type="checkbox"/>	<input type="checkbox"/>	
TDOT Design Guidelines	<input type="checkbox"/>	<input type="checkbox"/>	<input type="checkbox"/>	<input type="checkbox"/>	
TDOT Standard Drawings	<input type="checkbox"/>	<input type="checkbox"/>	<input type="checkbox"/>	<input type="checkbox"/>	
Guidance from other states	<input type="checkbox"/>	<input type="checkbox"/>	<input type="checkbox"/>	<input type="checkbox"/>	
Other					

DESCRIBE THE REASONING AND JUSTIFICATION OF THE DESIGN WAIVER REQUEST:
 (Address project needs, with consideration of all transportation modes, community engagement, safety, and with consistency towards long term planning and vision. Provide an explanation of the requested design waiver and describe other nationally recognized guidance that is met and that the design is based upon. Attach documentation of the specific design guidance met. The justification may need to include details such as: cross slope, superelevation rate, horizontal curve radius, stopping site distance, maximum grade, vertical clearance, etc.)

Figure 2-7 (Continued)
Design Waiver Request Form

TDOT ROADWAY DESIGN GUIDELINES
CHAPTER 2 GEOMETRIC DESIGN CRITERIA

English

Revised: 04/24/2023

DESCRIBE THE ALTERNATIVES CONSIDERED
(Provide an explanation of proposed mitigation measures to offset impact such as cost, ROW, environmental, multimodal, safety and operation, community and usability, or compatibility with adjacent section of the roadway)

DESIGN WAIVER IS REVIEWED AND RECOMMENDED FOR APPROVAL BY:

Regional Project Development Director

Click here to enter a date.
Date

DESIGN WAIVER APPROVED BY:

Roadway Design Division Director or
Designee

Click here to enter a date.
Date

Reviewer Comments Attached
 Additional Design Waiver Information Attached

Page 6 of 6

02/11/20

Figure 2-7 (Continued)
Design Waiver Request Form

SECTION 3 – INTERSECTIONS

2-300.00 INTERSECTIONS

Intersections are either at-grade which means two roads meet and cross each other or are grade-separated such as an interchange. Intersections are either uncontrolled, controlled by traffic signals/signs, shared spaces (such as a roundabout), or are interchanges. Chapter 3, Multimodal Design, shall be used to ensure that bicycle, pedestrian, and transit are considered in addition to roadway traffic. The guidelines also ensure compliance with the Americans with Disabilities Act (ADA) and Public Rights-of-Way Accessibility Guidelines (PROWAG). For more information, please see the TDOT [Multimodal Project Scoping Manual](#).

2-301.00 LANE DROP AFTER INTERSECTION

Existing two-lane highways are often widened to a multi-lane section at intersections to provide additional capacity (especially at signalized locations). When this occurs, the lane may be dropped at the intersection at a cross road or may carry through and transition after the intersection.

In order to address the resulting lane drop situation, follow the schematic shown in *Figure 2-8, Minimum Length (X) for Lane Extensions through an Intersection Width*, which shows the minimum length for the additional through lanes required to adequately sign the lane drop and minimize lane changing within the intersection. Use *Table 2-2, Guidelines for Advance Placement of Warning Signs*, to help find the “d” value reflected in *Figure 2-8, Minimum Length (X) for Lane Extensions through an Intersection Width*. An example for computing the required transition lengths is also included with this figure.

TDOT ROADWAY DESIGN GUIDELINES
CHAPTER 2 GEOMETRIC DESIGN CRITERIA

English

Revised: 04/24/23

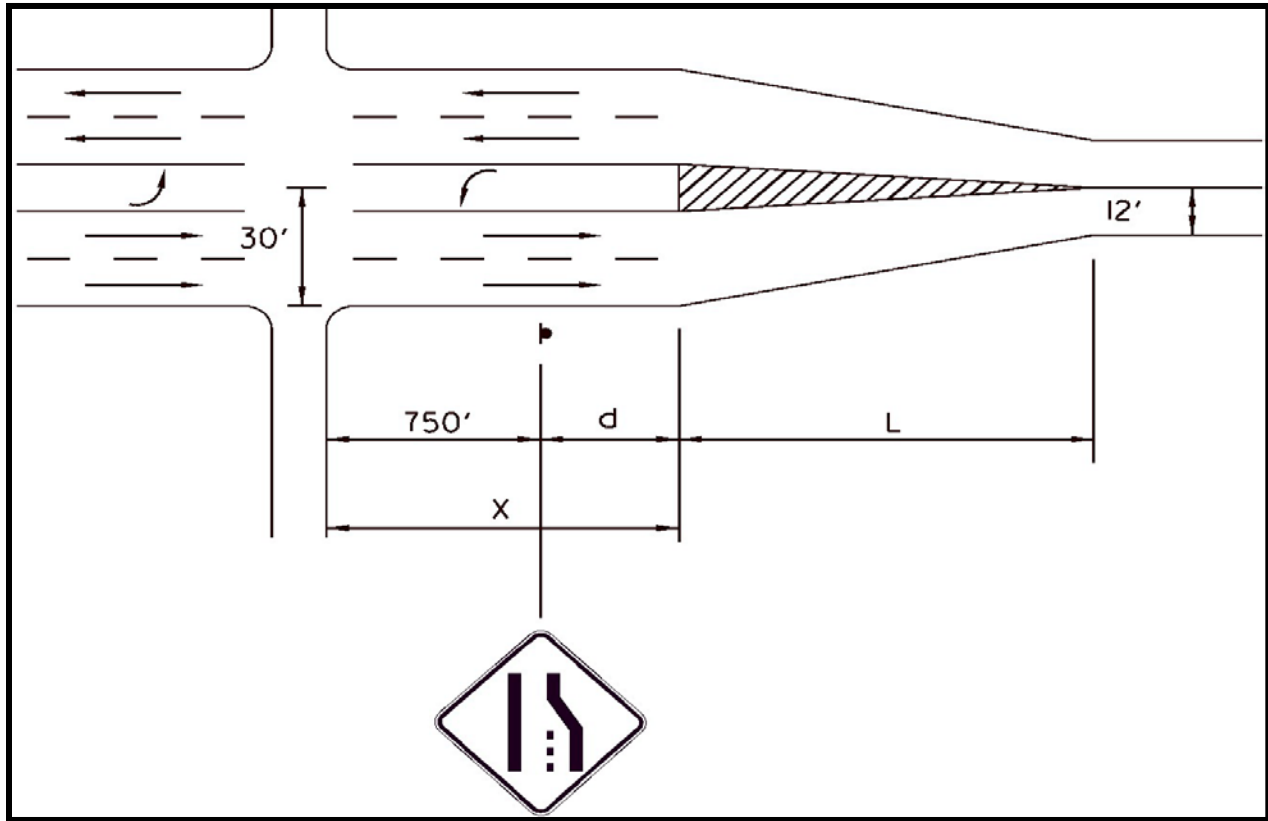

Figure 2-8
Minimum Length (X) for Lane Extensions through an Intersection Width

Lane Reduction Taper (L)

$$L = (S^2 \times W)/60 \text{ (for speed less than 45 mph)}$$

$$L = S \times W \text{ (for speed 45 mph or more)}$$

750 ft = Minimum distance at which sign is not visible to traffic approaching intersection (in order to minimize lane changing within intersection).

d = As required by *M.U.T.C.D.*, Sec. 2C.05, Table 2C-4, Condition A.

L = Transition length, as required by *M.U.T.C.D.*, Sec. 3B.09, Fig. 3B-14.

Note 1 Terminating the outside lane as a right-turn lane at an intersection may be considered subject to the review and approval of the TDOT Signal Section and the Design Manager.

Note 2 See *M.U.T.C.D* Section 2C.42 for guidance, options, and standard use of Lane Ends Signs.

TDOT ROADWAY DESIGN GUIDELINES
CHAPTER 2 GEOMETRIC DESIGN CRITERIA

English

Revised: 04/24/23

To find “d” use the following table:

Posted or 85th Percentile Speed	Advance Placement Distance ¹								
	Condition A: Speed reduction and lane changing in heavy traffic ²	Condition B: Deceleration to the listed Advisory Speed (mph) for the Condition							
		0 ³	10 ⁴	20 ⁴	30 ⁴	40 ⁴	50 ⁴	60 ⁴	70 ⁴
20 mph	225 ft	100 ft ⁶	N/A ⁵	-	-	-	-	-	-
25 mph	325 ft	100 ft ⁶	N/A ⁵	N/A ⁵	-	-	-	-	-
30 mph	460 ft	100 ft ⁶	N/A ⁵	N/A ⁵	-	-	-	-	-
35 mph	565 ft	100 ft ⁶	N/A ⁵	N/A ⁵	N/A ⁵	-	-	-	-
40 mph	670 ft	125 ft	100 ft ⁶	100 ft ⁶	N/A ⁵	-	-	-	-
45 mph	775 ft	175 ft	125 ft	100 ft ⁶	100 ft ⁶	N/A ⁵	-	-	-
50 mph	885 ft	250 ft	200 ft	175 ft	125 ft	100 ft ⁶	-	-	-
55 mph	990 ft	325 ft	275 ft	225 ft	200 ft	125 ft	N/A ⁵	-	-
60 mph	1,100 ft	400 ft	350 ft	325 ft	275 ft	200 ft	100 ft ⁶	-	-
65 mph	1,200 ft	475 ft	450 ft	400 ft	350 ft	275 ft	200 ft	100 ft ⁶	-
70 mph	1,250 ft	550 ft	525 ft	500 ft	450 ft	375 ft	275 ft	150 ft	-
75 mph	1,350 ft	650 ft	625 ft	600 ft	550 ft	475 ft	375 ft	250 ft	100 ft ⁶

Table 2-2
Guidelines for Advance Placement of Warning Signs

Reference: M.U.T.C.D. 2009 Manual (Table 2C-4 of Section 2C.05)

Notes:

¹The distances are adjusted for a sign legibility distance of 180 ft for Condition A. The distances for Condition B have been adjusted for a sign legibility distance of 250 feet, which is appropriate for an alignment warning symbol sign.

For Conditions A and B, warning signs with less than 6-inch legend or more than four words, a minimum of 100 feet should be added to the advance placement distance to provide adequate legibility of the warning sign.

²Typical conditions are locations where the road user must use extra time to adjust speed and change lanes in heavy traffic because of a complex driving situation. Typical signs are Merge and Right Lane Ends. The distances are determined by providing the driver a PRT of 14.0 to 14.5 seconds for vehicle maneuvers (2005 AASHTO Policy, Exhibit 3-3, Decision Sight Distance, Avoidance Maneuver E) minus the legibility distance of 180 feet for the appropriate sign.

³Typical condition is the warning of a potential stop situation. Typical signs are Stop Ahead, Yield Ahead, Signal Ahead, and Intersection Warning signs. The distances are based on the 2005 AASHTO Policy, Exhibit 3-1, Stopping Sight Distance, providing a PRT of 2.5 seconds, a deceleration rate of 11.2 feet/second², minus the sign legibility distance of 180 feet.

⁴Typical conditions are locations where the road user must decrease speed to maneuver through the warned condition. Typical signs are Turn, Curve, Reverse Turn, or Reverse Curve. The distance is determined by providing a 2.5 second PRT, a vehicle deceleration rate of 10 feet/second², minus the sign legibility distance of 250 ft.

⁵No suggested distances are provided for these speeds, as the placement location is dependent on site conditions and other signing. An alignment warning sign may be placed anywhere from the point of curvature up to 100 feet in advance of the curve. However, the alignment warning sign should be installed in advance of the curve and at least 100 feet from any other signs.

⁶The minimum advance placement distance is listed as 100 feet to provide adequate spacing between signs.

TDOT ROADWAY DESIGN GUIDELINES
CHAPTER 2 GEOMETRIC DESIGN CRITERIA

English

Revised: 04/24/23

EXAMPLE:

For Condition A: Speed Reduction and Lane Changing in Heavy Traffic:

Posted speed = 55 mph

$X = 750 \text{ feet} + d = 750 \text{ feet} + 990 \text{ feet} = 1,740 \text{ feet}$

$L = S \times W$ (for speed 45 mph or more) = $55 \times 18 = 990 \text{ feet}$

Where:

S = Posted speed (55 mph)

W= Transition Width (30 feet – 12 feet = 18 feet)

For Condition B: Deceleration from Posted speed of 55mph to speed of 30 mph:

$X = 750 \text{ feet} + d = 750 \text{ feet} + 200 \text{ feet} = 950 \text{ feet}$

$L = (S^2 \times W)/60$ (for speed less than 45 mph) = $(55^2 \times 18)/60 = 907.5 \text{ feet}$

Where: S = Posted speed (55 mph)

W= Transition Width (30 feet – 12 feet = 18 feet)

2-302.00 TURNING LANES AT INTERSECTIONS

Left and right turn lanes are added at intersections to increase capacity and improve safety and traffic flow.

The following guidelines are applicable to right and left-turn lanes and give procedures for desirable design. Design may be limited by geometric or other constraints, but these guidelines shall be followed as closely as possible. Figure 2-9 shows the terminology for turning lanes.

TDOT ROADWAY DESIGN GUIDELINES
CHAPTER 2 GEOMETRIC DESIGN CRITERIA

English

Revised: 04/24/23

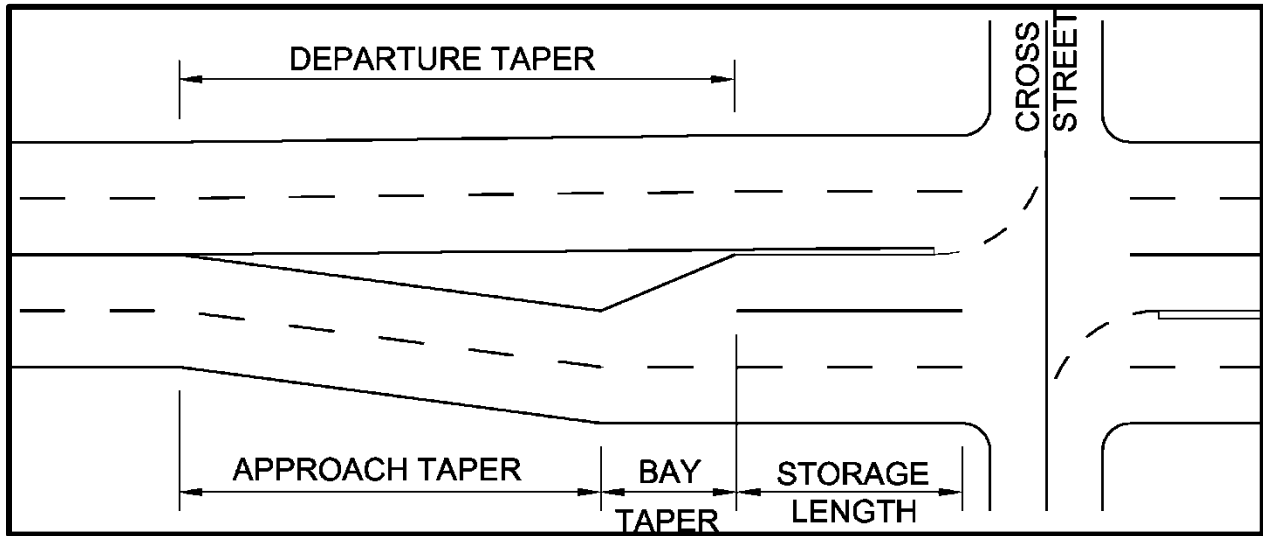

Figure 2-9
Turning Lane Terminology

1) APPROACH TAPER

(a) $L = W \times S$, Speed ≥ 45 mph

(b) $L = \frac{WS^2}{60}$, Speed < 45 mph

Where L = Length of Taper in feet

W = Width of Offset in feet

S = Design Speed in miles per hour

2) BAY TAPER

$L = \frac{WS}{3}$, L, W, S as defined for approach taper above.

3) STORAGE LENGTHS

a) Unsignalized Intersections

To determine a warrant for a required storage length, see *A Policy of Geometric Design of Highways and Streets*, AASHTO, 2011, Table 9-23, page 9-132. This table is a condensed

TDOT ROADWAY DESIGN GUIDELINES
CHAPTER 2 GEOMETRIC DESIGN CRITERIA

English

Revised: 04/24/23

version of the Harmelink charts for two-lane highways, or the designer can also refer to the [Harmelink Guide](#) for the Harmelink charts.

Select the appropriate chart for design speed and percentage of left turns. Use the total advancing volume for the approach (left, through, and right) on the bottom axis of the chart, and the total opposing volume on the left axis of the chart.

b) Signalized Intersections

Storage lengths at signalized intersections are a function of signal timings, volumes, and saturation flow rates. Assistance in determining storage lengths can be provided by the Traffic Operations Division, Signal and Lighting Section.

4) DEPARTURE TAPER

The departure taper begins at the end of the storage lane and ends at the beginning of the approach taper.

Additional Considerations:

- i) When the left-turn volume exceeds 300 vph, a double left-turn lane shall be considered. A capacity analysis will help determine the benefit of an additional lane. If a double left is proposed, use 60% of the turn volume to determine the storage length for each lane.
- ii) It is suggested in *A Policy of Geometric Design of Highways and Streets*, AASHTO, 2011, Chapter 9, that it is desirable to provide the appropriate deceleration distance for vehicles entering a left or right-turn lane. This distance can be considered to be the sum of the bay taper and the storage length for minimum design. These lengths are shown in *Table 2-3, Approximate Total Lengths Needed for Deceleration to a Stop from Design Speed*.

TDOT ROADWAY DESIGN GUIDELINES
CHAPTER 2 GEOMETRIC DESIGN CRITERIA

English

Revised: 04/24/23

Design Speed (mph)	Deceleration Length to Stop Condition for Less Than 3% Grade (ft)
30	160
40	275
50	425
60	605
70	820

Table 2-3
Approximate Total Lengths Needed for Deceleration to a Stop from Design Speed

Reference: A Policy on Geometric Design of Highways and Streets, AASHTO, 2011, Table 9-22
 For deceleration on grades greater than 3% see *Table 3-2, Stopping Sight Distance on Grades, A Policy on Geometric Design of Highways and Streets, AASHTO, 2011.*

Providing deceleration lengths is not normally feasible on urban facilities.

When the deceleration length is to be provided, and this length exceeds the bay taper plus storage length, the additional length shall be provided as storage and the bay taper kept constant.

- iii) As suggested in the *2016 Highway Capacity Manual*, TRB, page 19-33, exclusive right-turn lanes shall be considered when the right-turn volume exceeds 300 vph and the adjacent through-lane volume also exceeds 300 vphpl. A capacity analysis will also provide a measure of the benefits of a right-turn lane to the overall intersection operation.
- iv) It shall be noted that at some intersections, lengths of turn lanes may be more a function of queue lengths in through lanes that might block access to turn lanes, thus reducing turn lane efficiency.

2-303.00 J-TURN INTERSECTIONS

A J-turn intersection is an intersection that prevents direct crossing and left-turn movements from the minor approach roadway. This is a variation of the restricted crossing u-turn (RCUT). It is often used in areas where the crash rate is high due to motorists attempting to cross a median into oncoming traffic traveling at a high speed. *Figure 2-10, J Turn in Maury County, TN*, is a J-turn located on Canaan Road and US 43/SR 6 in Mt. Pleasant, Maury County, TN. This J-turn was constructed because there were several crashes at the intersection with over 50% involving right angle collisions and a posted speed of 55 mph. From the figure, the J-turn requires side road movements to be made indirectly by making a right turn into traffic (move 1) (opposite than the direction they want to travel), traveling about a quarter-mile on the divided main road (moves 2-3-4), turning left into the median (move 5), proceeding to the J-Turn area (move 6) until it is safe to proceed into traffic (move 7) in the original direction they want to go.

TDOT ROADWAY DESIGN GUIDELINES
CHAPTER 2 GEOMETRIC DESIGN CRITERIA

English

Revised: 04/24/23



Figure 2-10
J Turn in Maury County, TN

2-304.00 INTERSECTIONS LOCATED NEAR THE LIMITS OF CONSTRUCTION

On new construction or reconstruction projects when an intersection is located at the beginning or end limit of construction the project shall comply with the following:

- A. If design of the intersection is included in the scope of the project defined by the technical report, the Designer shall include the entire intersection (i.e. place the construction limit at a point beyond the stop bar on the far side of the intersection from the project.) **This includes installing updates to ensure all ADA and PROWAG measures are met.**
- B. If design of the intersection is not included in the scope of the work defined by the technical report, the Designer shall exclude the entire intersection (i.e. place the construction limit at a point no closer than the stop bar on the near side of the intersection from the project.)
- C. In no case shall the Designer place the construction limits between the stop bars of a signalized intersection.

SECTION 4 – INTERCHANGES

2-400.00 INTERCHANGES

There are several types of interchanges including diamond, directional, cloverleaf, single point urban interchanges (SPUI), and diverging diamonds. Information on Interchanges can be found in *A Policy of Geometric Design of Highways and Streets*, Chapter 10, AASHTO, 2011. See *Figure 2-11, Types of Interchanges*.

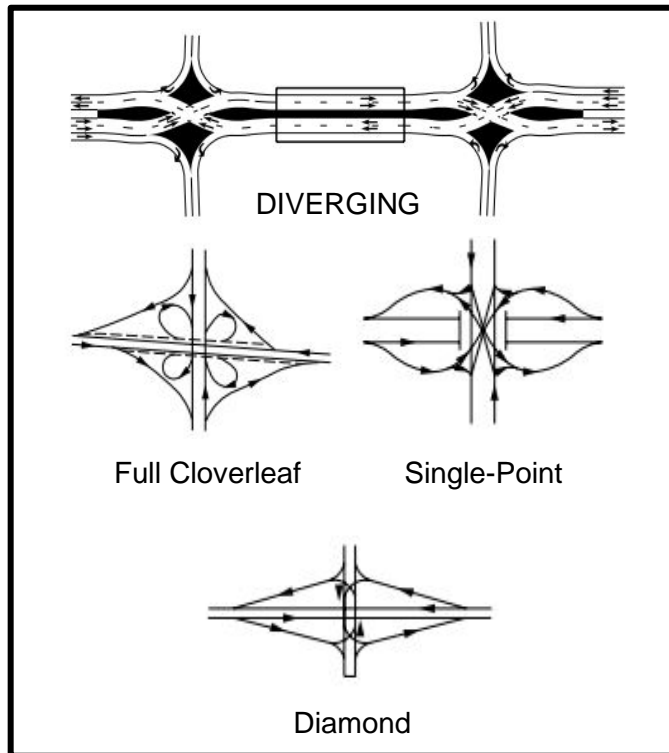

**Figure 2-11
Types of Interchanges**

2-400.01 INTERCHANGE RAMP DESIGN

A ramp is used to connect two or more legs at an interchange. They are composed of a terminal at each leg and a connecting road. See *A Policy of Geometric Design of Highways and Streets*, Section 10.9.6.1, AASHTO, 2011 for more information. See *Figure 2-12, Common Ramp Types*.

TDOT ROADWAY DESIGN GUIDELINES
CHAPTER 2 GEOMETRIC DESIGN CRITERIA

English

Revised: 04/24/23

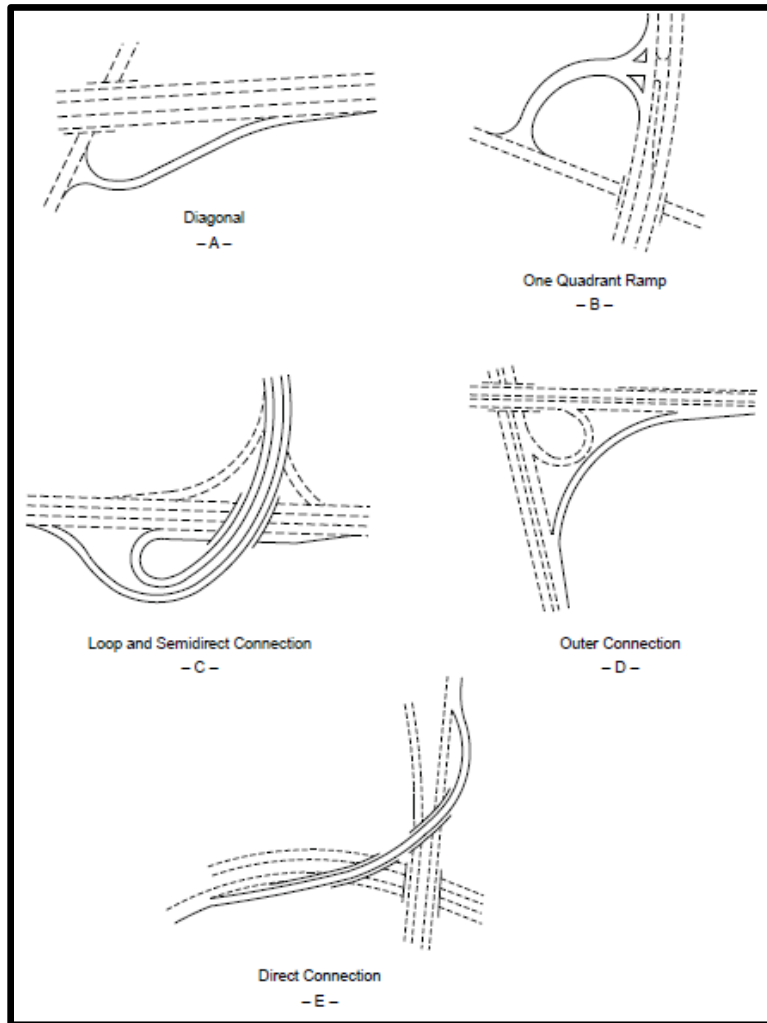

Figure 2-12
Common Ramp Types

2-400.02 TWO-LANE ENTRANCE RAMPS ON FREEWAYS AND EXPRESSWAYS

Designers shall use the parallel design when introducing two-lane entrance ramps to freeways and expressways. Parallel ramps are preferred on both single and multi-lane ramps.

The parallel design is preferable for two reasons: (1) past experience with the tapered design has been undesirable from an operational and safety standpoint; (2) uniformity of design due to the fact that most two-lane entrance ramps statewide are the parallel type.

For examples of the parallel design for two-lane entrance ramps, refer to *A Policy on Geometric Design of Highways and Streets*, AASHTO, 2011, Figure 10-73 and Figure 10-74.

TDOT ROADWAY DESIGN GUIDELINES
CHAPTER 2 GEOMETRIC DESIGN CRITERIA

English

Revised: 04/24/23

2-400.03 ACCESS CONTROL AT INTERCHANGE RAMPS

The extent of the access control for rural highways shall be 300 feet from the ramp terminal, treating each side of the crossroad independently. Thus, where the interchange ramp terminals at the crossroad are not opposite each other, the limits of access control will not be opposite; each being 300 feet from the ramp terminal which governs. For urban highways, the extent of access control shall be 100 feet. See *Geometric Design of Highways and Streets*, AASHTO, 2011, for more information.

TDOT ROADWAY DESIGN GUIDELINES
CHAPTER 2 GEOMETRIC DESIGN CRITERIA

English

Revised: 04/24/23

SECTION 5 – MEDIANS

2-500.00 MEDIANS

Safety and improved traffic operations dictate the need for providing roadways with medians in the State of Tennessee. Median widths are shown in the RD11-TS series - Typical Sections and Design Criteria section of the Roadway Standard Drawings. Due to safety concerns, many median divided roadways are access controlled and do not allow an opening for every private drive.

2-500.01 MEDIAN OPENING SPACING

Since the number of median openings per mile has a significant effect on crash potential, it is important that such openings be held to a reasonable minimum and in the interests of equity, are only permitted at predetermined uniformly spaced specific locations. This procedure will provide a high degree of safety to the motoring public and also permit reasonable access to abutting property owners. It is the policy of the Department to provide median openings at most existing city streets or county roads. It is also the policy of the Department to provide uniformly spaced openings between median openings for city streets or county roads for to allow vehicles to make a U-turn. The desirable uniform spacing is 1,320 feet (a range of 880 feet - 1,760 feet is acceptable) in rural areas and 660 feet (a range of 440 feet - 880 feet is acceptable) in urban areas.

Location of crossovers set by this policy shall be adjusted if safety considerations so dictate. An example is as follows: in order to minimize the potential for wrong way movements, adjustment of proposed crossover locations to align with an existing driveway shall be considered if the driveway centerline is within 75 feet of the proposed crossover centerline.

2-500.02 MEDIAN OPENING SPACING - EXAMPLES

Four example problems detailing the procedure to be used in determining the appropriate median opening spacing are as follows (See Figure 2-13, *Urban Section Example*, 2-14, *Median Opening Example*, and 2-15, *Rural Section Example*). Additional examples are available in the [Median Opening Spacing Examples](#) document located on the [Tutorials and Training Guides](#) webpage.

TDOT ROADWAY DESIGN GUIDELINES
CHAPTER 2 GEOMETRIC DESIGN CRITERIA

English

Revised: 04/24/23

Example No. 1 **Urban Section**

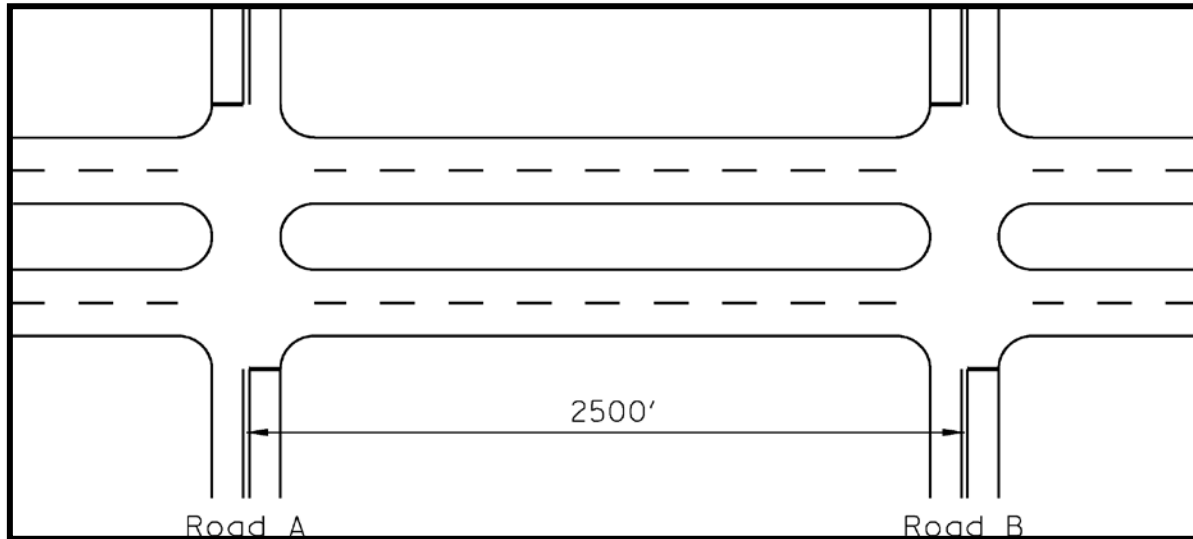

Figure 2-13
Urban Section Example

Total distance between Road A and Road B is 2,500 feet. Since this is within an urban section of roadway, the appropriate median opening spacing would be that which most closely approximates 660 feet. It shall not, however, be less than 440 feet nor more than 880 feet.

The first step in determining the proper spacing is to divide the total distance between the intersection openings (2,500 feet) by the desirable urban spacing (660 feet). This will tell us the approximate number of spaces required.

This calculates to 3 or 4 spacings (2 or 3 midblock median openings) between Road A and Road B. The number of midblock median openings is always one less than the number of spaces. Generally the whole number closest to the approximate number of spaces (4 for 3.79 above) will be the number of spaces which will yield the most appropriate median opening spacing (which is true in this particular example). However, this is not always the case (see Example No. 8 in the [Median Opening Spacing Examples](#) document).

The next step is to determine which condition would result in spacing nearest to 660 feet, but within the range of 440 feet to 880 feet. To do this, first divide the total distance between the intersections (2,500 feet) by the possible number of spacings (3 and 4). At the same time, check to see if the resulting distances are within the permissible range (440 feet - 880 feet). If the resulting distance is not within this range, discard it as an alternative.

$$\frac{2500}{3} = 833 \quad 440 < 833 < 880 \quad \text{OK}$$

TDOT ROADWAY DESIGN GUIDELINES
CHAPTER 2 GEOMETRIC DESIGN CRITERIA

English

Revised: 04/24/23

$$\frac{2500}{4} = 625 \quad 440 < 625 < 880 \quad \text{OK}$$

Both possible spacings (833 feet and 625 feet) are within the permissible range. Therefore, it must still be determined which is closest to 660 feet.

$$\begin{aligned} 833 - 660 &= 173 \\ 660 - 625 &= 35 \end{aligned}$$

Since 35 is less than 173, the most appropriate median opening spacing between Road A and Road B would be 625 feet. This would result in 3 midblock median openings 625 feet apart as shown in Figure 2-14, *Median Opening Example*.

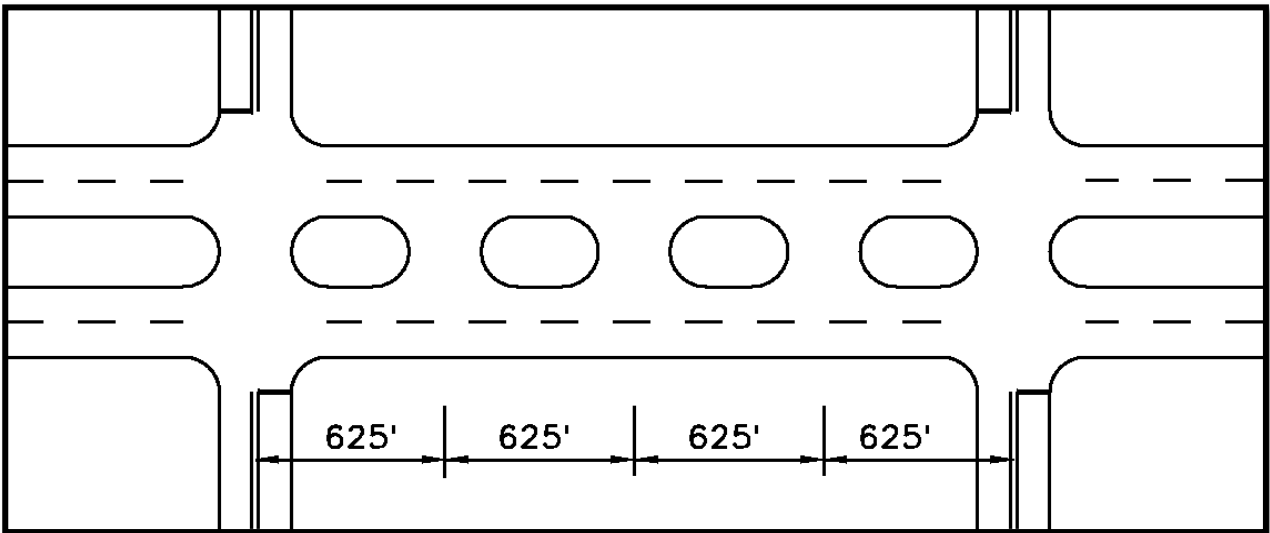

Figure 2-14
Median Opening Example

Example No. 2 **Urban Section**

Total distance between intersection openings is 1,100 feet.

$$\frac{1100}{660} = 1.7$$

$$\frac{1100}{1} = 1100 \quad 440 < 1100 > 880 \quad \text{Not Acceptable}$$

$$\frac{1100}{2} = 550 \quad 440 < 550 < 880 \quad \text{OK}$$

TDOT ROADWAY DESIGN GUIDELINES
CHAPTER 2 GEOMETRIC DESIGN CRITERIA

English

Revised: 04/24/23

The only acceptable spacing is 550 feet. Therefore, one midblock median opening shall be provided at a point 550 feet from each intersection.

Example No. 3 **Rural Section**

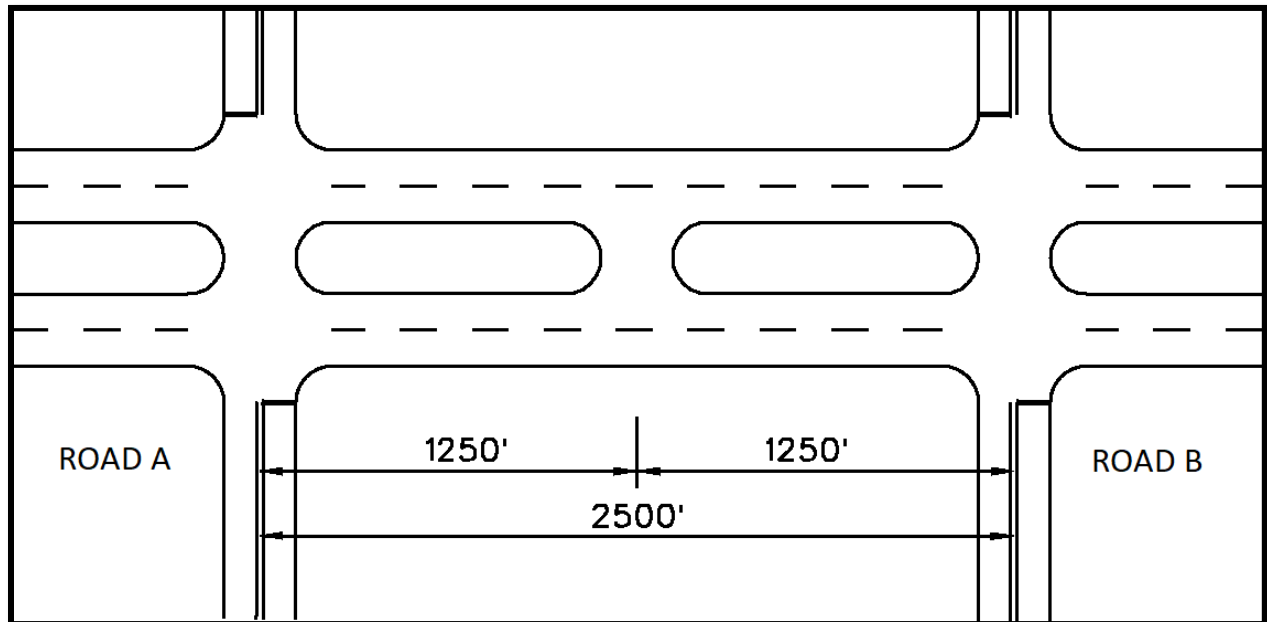

Figure 2-15
Rural Section Example

Total distance between Road A and Road B is shown in Figure 2-15 as 2,500 feet. The desirable rural spacing is 1,320 feet, with a range of between 880 feet and 1,760 feet.

$$\frac{2500}{1320} = 1.9$$

Therefore, there can be 1 or 2 spacing's (0 or 1 midblock median opening). However, it must be determined which condition would result in a spacing nearest 1,320 feet, but also be within the permissible range.

$$\frac{2500}{1} = 2500 \quad 880 < 2500 > 1760 \quad \text{Not Acceptable}$$

TDOT ROADWAY DESIGN GUIDELINES
CHAPTER 2 GEOMETRIC DESIGN CRITERIA

English

Revised: 04/24/23

$$\frac{2500}{2} = 1250 \quad 880 < 1250 < 1760 \quad \text{OK}$$

The only acceptable median opening spacing between Road A and Road B is 1,250 feet. Therefore, one midblock median opening shall be provided at a point 1,250 feet from each intersection.

Example No. 4 Rural Section

Total distance between intersection openings is 1,100 feet.

$$\frac{1100}{1320} = 0.8$$

$$\frac{1100}{0} = \infty \quad \infty < 1100 \quad \text{Not Acceptable}$$

$$\frac{1100}{1} = 1100 \quad 880 < 1100 < 1760 \quad \text{OK}$$

The only acceptable spacing is 1,100 feet and, therefore, no midblock median opening shall be installed.

2-500.03 LEFT TURN LANES IN MEDIANS

As discussed in *A Policy of Geometric Design of Highways and Streets*, Chapter 9, it is desirable to align left-turn lanes in medians – see *Figure 2-16, Left-Turn Lane Alignment*. The advantages of this placement are:

- a) Better visibility of opposing through traffic as left turners look for gaps.
- b) Decreased conflict between opposing left-turn vehicle paths.
- c) Increased numbers of left-turn vehicles served in a given period of time. The farther left the turn lane, the shorter the crossing distance for left-turn vehicles, allowing drivers to choose shorter gaps in opposing traffic and clear the intersection. There is also an increase in capacity at signalized intersections, due to more flexibility in left-turn phasing and shorter clearance intervals.

The following guidelines apply to four-lane divided highways with a maximum median width of 48 feet. For medians greater than 48 feet, designers should offset left turn lanes to reduce the length required for the left turn onto an intersecting road.

The centerline of left-turn lanes shall be placed along the centerline of the median, so that opposing left-turn lanes are directly opposite each other. Excess pavement area between the turn lane and adjacent through lane shall be marked with channelization striping (see *Figure 2-16, Left-Turn Lane Alignment*).

TDOT ROADWAY DESIGN GUIDELINES
CHAPTER 2 GEOMETRIC DESIGN CRITERIA

English

Revised: 04/24/23

The ADT criteria as shown in *Table 2-4, Future Traffic Signal Warrants*, can be used to estimate if a traffic signal will be warranted within five years of project opening. If the current major street ADT and minor street ADT both meet the criteria for Warrant 1 or Warrant 2, future signalization is probable, and the intersection design shall provide aligned left-turn lanes.

The number of approach lanes on the major street includes only through lanes. The same is true for the minor street, except in the case of "T"-intersections. For "T"-intersections, the number of approach lanes shall include left and right-turn lanes (if present) for the stem of the "T" as the minor street.

If the major street ADT differs on each side of the intersection, an average shall be used. For the minor street, use the higher ADT on the higher volume approach.

Be aware that there may be special conditions affecting signalization or geometric design. For those unusual conditions, the Traffic Operations Division can provide assistance.

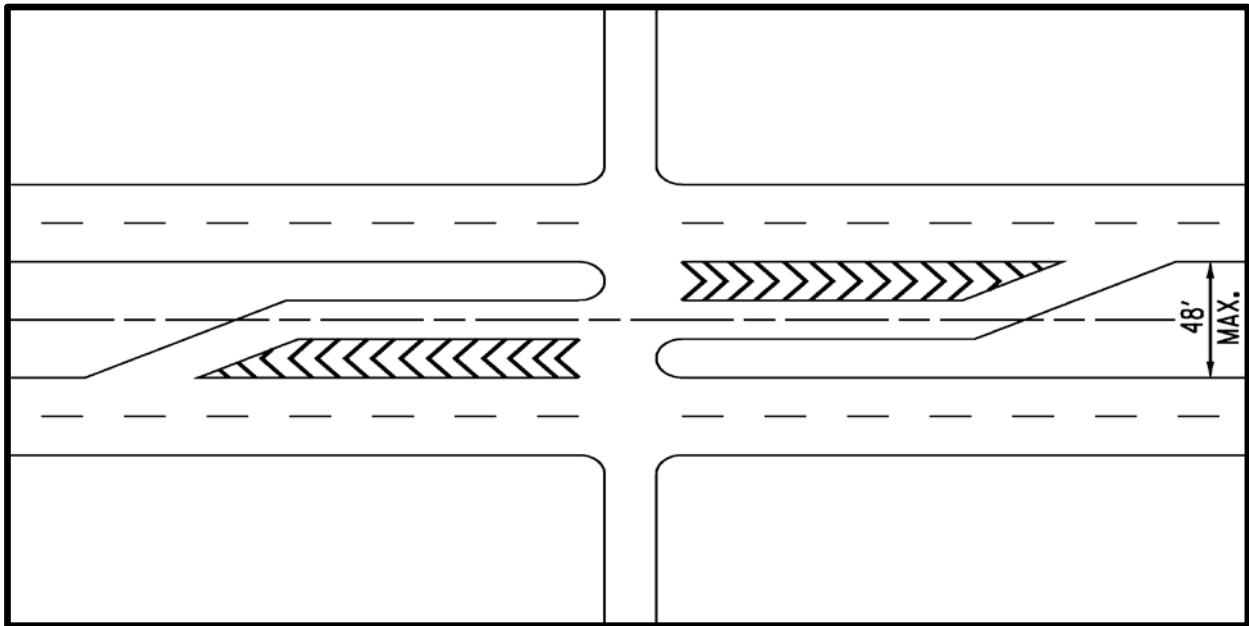

Figure 2-16
Left-Turn Lane Alignment

TDOT ROADWAY DESIGN GUIDELINES
CHAPTER 2 GEOMETRIC DESIGN CRITERIA

English

Revised: 04/24/23

NUMBER OF APPROACH LANES		WARRANT 1		WARRANT 2	
Major	Minor	Major ADT	Minor ADT	Major ADT	Minor ADT
1	1	5000	3000	7500	1500
2 or more	1	6000	3000	9000	1500
2 or more	2 or more	6000	4000	9000	2000
1	2 or more	5000	4000	7500	2000

Table 2-4
Future Traffic Signal Warrants

VOLUME WARRANTS FOR LEFT - TURN STORAGE LANES
AT UNSIGNALIZED GRADE INTERSECTIONS

CHART VALUE	% T _L = % TRUCKS IN V _L					
	0%	10%	20%	30%	40%	50%
75'	0	25'	25'	25'	50'	50'
100'	0	25'	25'	50'	50'	50'
125'	0	25'	25'	50'	50'	75'
150'	0	25'	50'	50'	75'	75'
175'	0	25'	50'	75'	75'	100'
200'	0	25'	50'	75'	100'	100'
250'	0	25'	50'	75'	100'	125'
300'	0	50'	75'	100'	125'	150'
350'	0	50'	75'	125'	150'	175'
400'	0	50'	100'	125'	175'	200'
450'	0	50'	100'	150'	200'	225'
500'	0	50'	100'	150'	200'	250'

Table 2-5
Storage Length to be Added to Chart Values of Left-Turn Lane Storage Lengths

TDOT ROADWAY DESIGN GUIDELINES
CHAPTER 2 GEOMETRIC DESIGN CRITERIA

English

Revised: 04/24/23

SECTION 6 – STRUCTURAL DESIGN

2-600.00 CONCRETE BOX AND SLAB TYPE CULVERTS AND BRIDGES

As structures are proposed or changed on projects, the impact to the environment shall be considered. Early consideration for the type of structure and construction of the structure shall be considered, especially when there are restrictions of piers being placed in the water or construction time restrictions. Precast, pre-stressed bridge deck panels will not be allowed to be used on concrete box or slab type culverts.

2-600.01 TYPE DESIGNATION

For each culvert or bridge, the plans must clearly indicate the type (box or slab) that should be used on the project. The type shall be shown and labeled on the plans along with corresponding quantities as noted in the checklists for each project stage.

The current Standard Drawings for box or slab type culverts or bridges are found in the Standard Structure Drawings. Special or new designs may be requested through the proper channels from the Structures Division.

For all projects having either concrete box and/or slab culverts or bridges projects, the Standard Drawing Index Sheet shall include the appropriate STD-17 series of drawings showing the particular structures that apply to the project.

2-600.02 PAVED APRON FOR BOX CULVERT AND BRIDGE OUTLETS

A paved apron may be used on concrete box culverts and bridges in selected locations as determined by the Design Manager if requested by the Structures or Construction Division. Standard Drawing STD-17-19 should be used when an apron is required.

The quantities shall be added to the concrete, steel, and foundation fill material quantities for the box culvert or slab bridge. Footnote these quantities to show the amount of concrete and steel bar reinforcement included for the paved aprons, when applicable. The steel bar reinforcement may be computed using a weight of 58 pounds per 100 square feet of apron, plus the weight of the A500 bars (use 3.13 pounds per bar).

2-600.03 CONCRETE BOX AND SLAB TYPE CULVERTS AND BRIDGES IN SHALLOW FILLS

On concrete box and slab type culverts and bridges where there is little or no fill to be placed on top of the structure and/or there are significant effects on construction due to grades, superelevation or curvature, the Designer shall place information on the plans as follows:

TDOT ROADWAY DESIGN GUIDELINES
CHAPTER 2 GEOMETRIC DESIGN CRITERIA

English

Revised: 04/24/23

- A. Where the horizontal curvature of the roadway, as opposed to the normally straight nature of the inlet and outlet, is sufficient that the guardrail may encroach on the shoulder and/or roadway (See *Figure 2-17, Potential Guardrail Encroachment*), the Designer shall investigate the need to have the inlet and outlet constructed on a curve parallel to the centerline of the roadway.

If curved inlets and/or outlets are required, a note similar to the one below shall be placed on the culvert section.

"The inlet and outlet ends of the box culvert at Sta. _____ shall be curved parallel to the centerline of the roadway."

- B. Where grades and/or superelevation cause significant effects on construction, the Designer shall show the following additional details and elevations on the culvert drainage section as shown in *Figure 2-18, Box Bridge or Culvert Elevation Details*:

1. Add detail of box showing flow line, top of wall and top of slab adjacent to vertical walls on both inlet and outlet ends.
2. Show elevations of top of curb and top of wingwalls to suit roadway grades and superelevation. The height of curb may vary; but shall not exceed a height of 2.5 feet above the top of the box. In the event this cannot be avoided, the Designer will contact the Hydraulics Section of the Structures Division to resolve the issue.

Provide a cross-section of the roadway on top of the box showing the asphalt paving needed on the box to obtain the roadway grade and proper pavement cross slope. See *Figure 2-19, Typical Cross-Section Information for Box and Slab Type Culverts and Bridges*.

3. Show crown or superelevation when the concrete top slab is to be the riding surface.
- C. Table 2-6, *Adjustment Factor for Estimating Additional Reinforcing Steel Quantities in the Vertical Walls of Concrete Box or Slab Type Culverts or Bridges* to determine the appropriate adjustment factor. (See associated *Figure 2-20, Typical Concrete Box or Slab Type Culvert or Bridge Modification*). The Structures Division will assist the Designer in these calculations, if assistance is requested.
- D. If the top slab is to be used as the riding surface and the design speed is less than 40 mph, the following note shall be added to the plans as a footnote for the concrete item for box bridges.

"Bridge deck finish to be burlap drag in accordance with method "A" as specified in Subsection 604.23 of the *Tennessee Department of Transportation Standard Specifications*."

TDOT ROADWAY DESIGN GUIDELINES
CHAPTER 2 GEOMETRIC DESIGN CRITERIA

English

Revised: 04/24/23

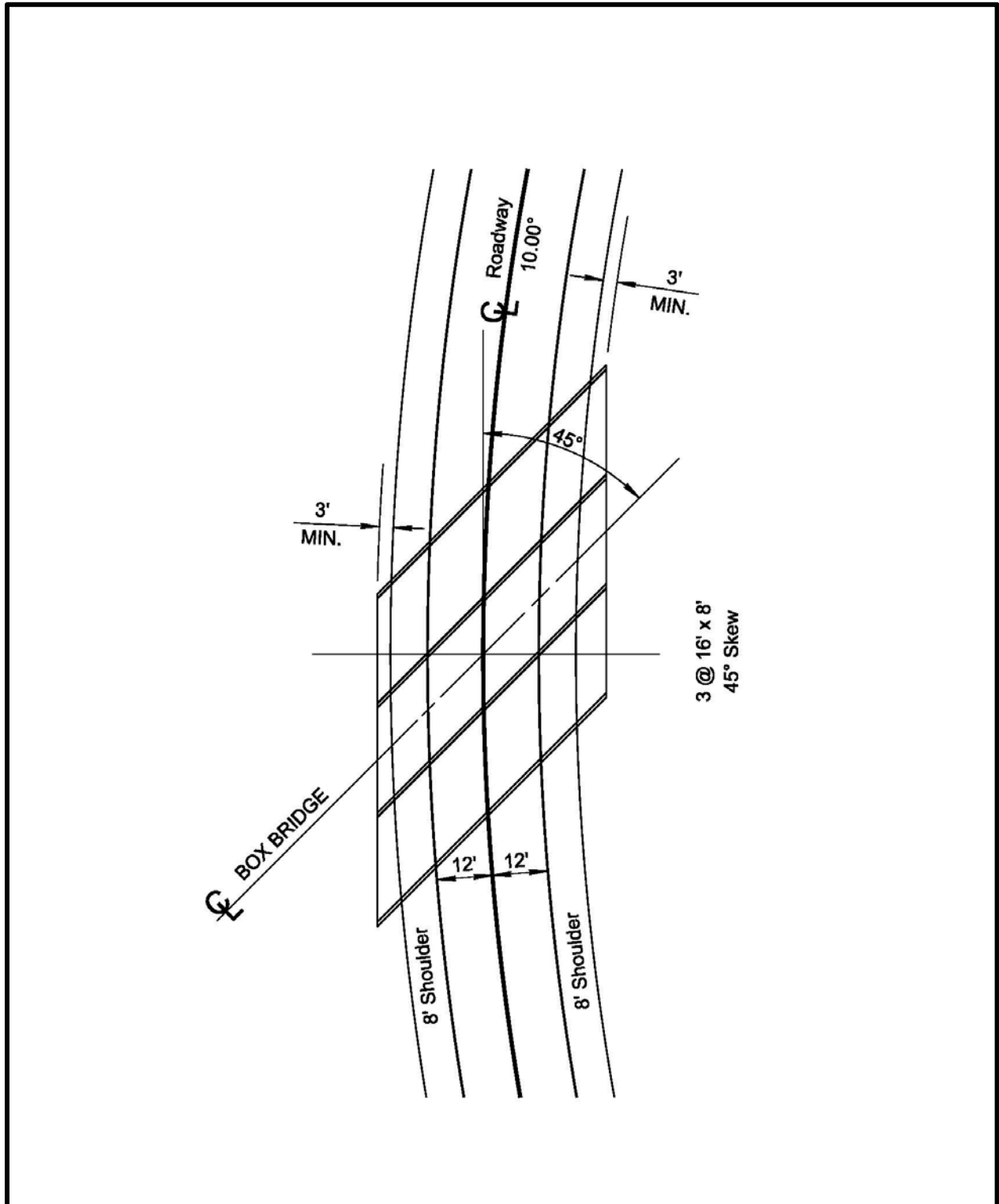

Figure 2-17
Potential Guardrail Encroachment

TDOT ROADWAY DESIGN GUIDELINES
CHAPTER 2 GEOMETRIC DESIGN CRITERIA

English

Revised: 04/24/23

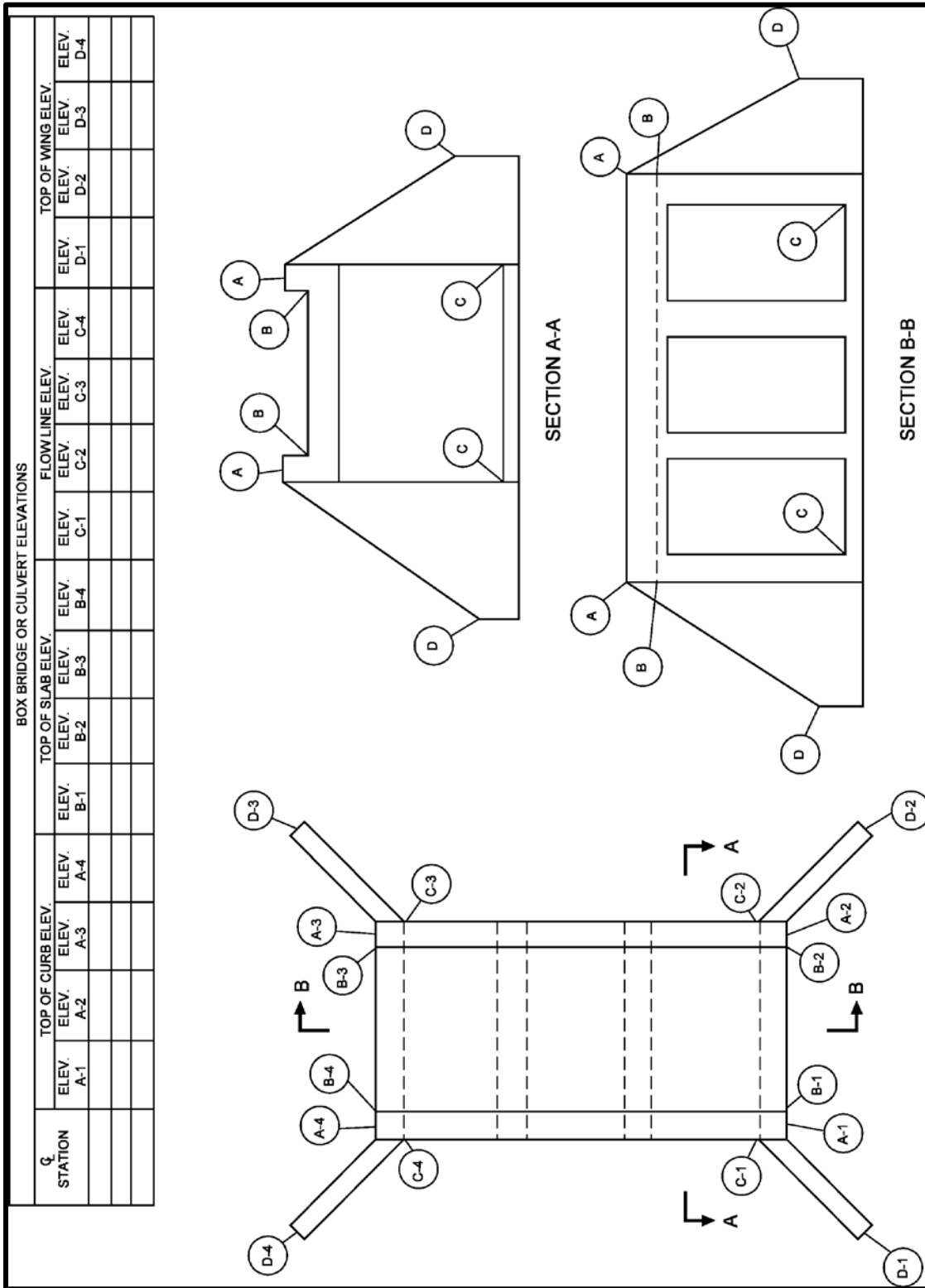

Figure 2-18
Box Bridge or Culvert Elevation Details

TDOT ROADWAY DESIGN GUIDELINES
CHAPTER 2 GEOMETRIC DESIGN CRITERIA

English

Revised: 04/24/23

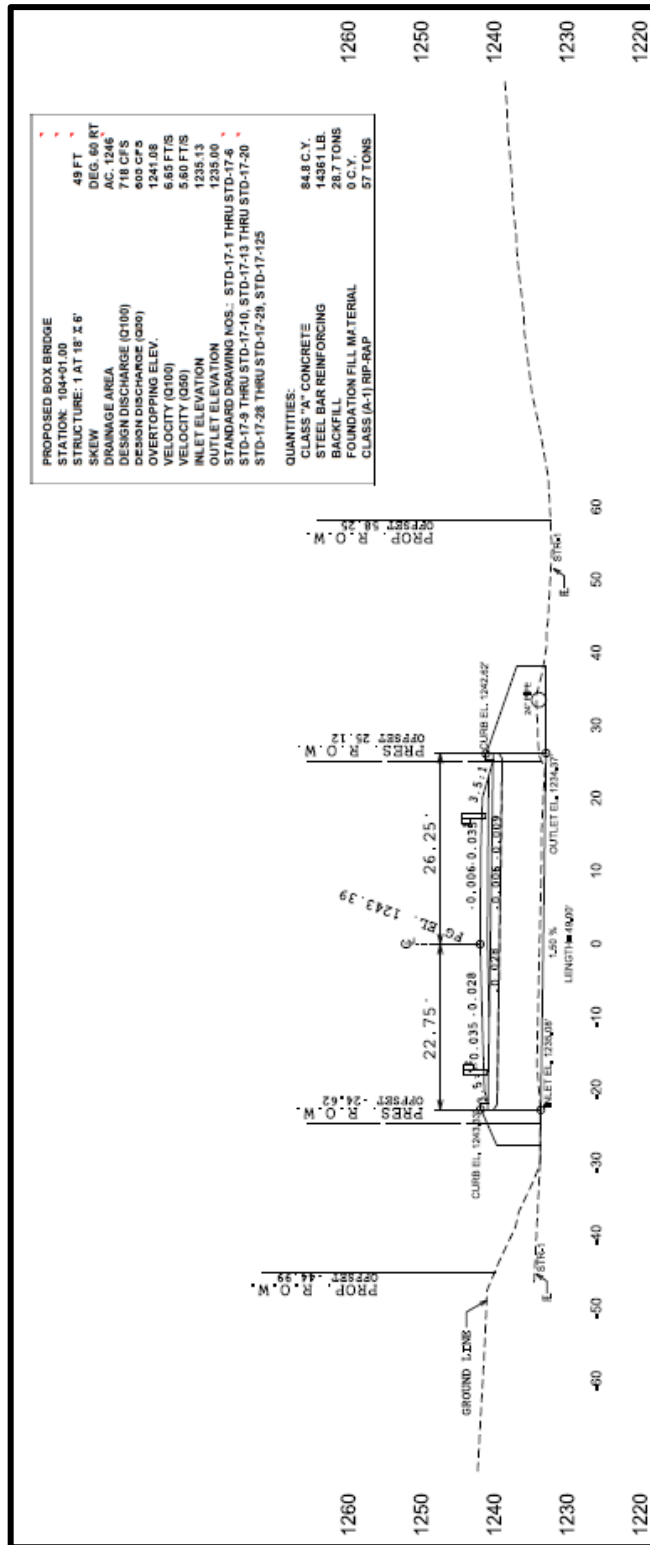

Figure 2-19

Typical Cross-Section Information for Box and Slab Type Culverts and Bridges

TDOT ROADWAY DESIGN GUIDELINES
CHAPTER 2 GEOMETRIC DESIGN CRITERIA

English

Revised: 04/24/23

ADJUSTMENT FACTOR FOR ESTIMATING ADDITIONAL REINFORCING STEEL QUANTITIES IN THE VERTICAL WALLS OF CONCRETE BOX OR SLAB TYPE CULVERTS OR BRIDGES					
SPAN IN FEET	WIDTH	*EXTERIOR IN LB./L.F./V.F.	WALL	*INTERIOR IN LB./L.F./V.F.	WALL
8		2.27		1.33	
10		2.45		1.50	
12		2.94		1.71	
14		3.94		2.17	
16		3.94		2.17	
18		3.94		2.17	

* ADDITIONAL POUNDS OF REINFORCING STEEL IN VERTICAL WALLS BASED ON POUNDS PER LINEAR FOOT ONE FOOT IN HEIGHT FOR ANY NUMBER OF BARRELS ON ANY SKEW. THIS TABLE IS GOOD FOR AN INCREASE IN WALL HEIGHT NOT EXCEEDING TWO FEET AND FILL HEIGHTS NOT EXCEEDING TWO FEET.

Table 2-6
Adjustment Factor for Estimating Additional Reinforcing Steel Quantities in the Vertical Walls of Concrete Box or Slab Type Culverts or Bridges

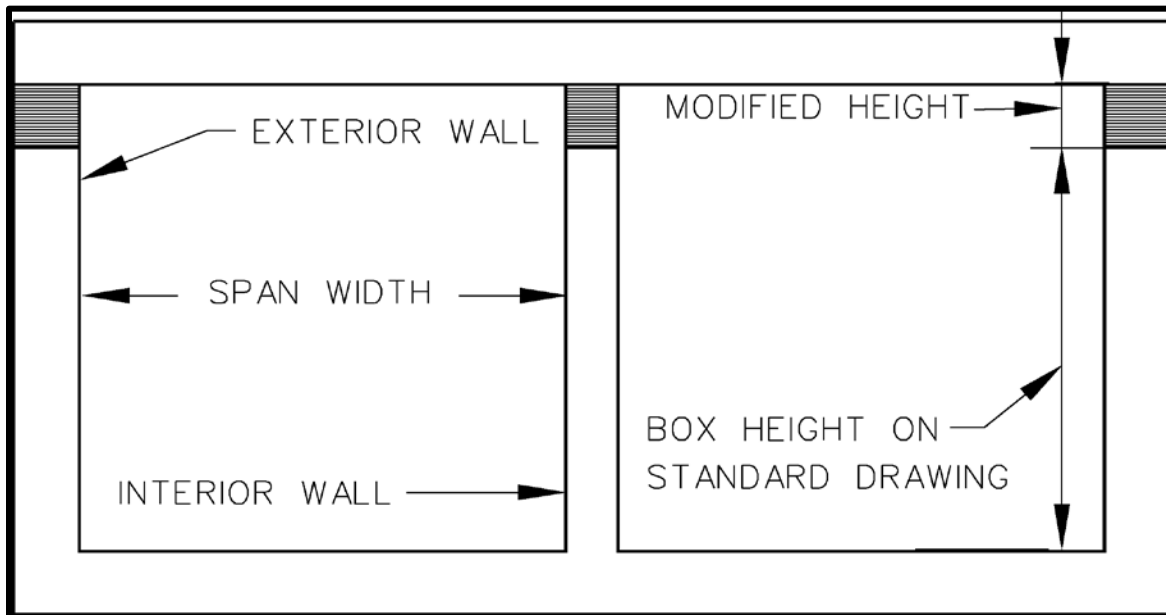

Figure 2-20
Typical Concrete Box or Slab Type Culvert or Bridge Modification

TDOT ROADWAY DESIGN GUIDELINES
CHAPTER 2 GEOMETRIC DESIGN CRITERIA

English

Revised: 04/24/23

2-600.04 STEEL BAR REINFORCEMENT (ROADWAY)

On all projects which include reinforced concrete box or slab type culverts or bridges, Standard Drawing STD-9-1, Standard Reinforcing Bar Support Details for Concrete Slabs, shall be listed on the appropriate culvert sheets and in the Structures Standard Drawing index.

If the top slab used on concrete box or slab type culverts or bridges is to be used as a riding surface or has less than 1 foot of fill over it, then epoxy-coated reinforcing steel is to be used in the top mat of the top slab and curbs, including tie bars for curbs and corner bars of the exterior walls. All other steel is to be in the form of black bars. The unit cost bid for Item Number 604-02.02, Steel Bar Reinforcement (Box Bridges), is to include any additional cost for epoxy-coated steel as noted on plans details or Standard Drawings.

If the project has a reinforced concrete deck bridge, STD-9-1 will appear in the bridge index and it will not be necessary to list it again in the roadway index.

2-601.00 HAUL ROADS

Haul roads are required to provide temporary access to facilitate the movement of equipment and materials on a project site during construction. Haul roads should encroach no further than the top of a stream bank. If access is needed to extend into or across a stream, this is considered a temporary stream crossing and Designers should refer to Standard Drawing EC-STR-25. For clarification purposes, this section is only referring to haul roads and not temporary stream crossings.

2-601.01 HAUL ROAD DESIGN CONSIDERATIONS

If a stream has Q50 discharge greater than or equal to 500 cfs, the Designer should request that the Hydraulics Section of the Structures Division prepare a hydraulic design of the haul road. Otherwise, Designers are responsible for designing the haul roads. Haul roads shall be shown on the Typical Section, Property Map, Present Layout, ROW Detail, Proposed Layout, Profile, Drainage Map, EPSC, Traffic Control, and Bridge Layout sheets. A separate sheet is not required for the haul road profile but if included with a side road, the sheet name shall be modified to include the haul road.

If the haul roads are strictly to be used for the transport of materials to the construction site, the haul road widths shall be a minimum of 22'-0". If the haul roads are also to be used for the staging of work, the haul road widths shall be increased to 38'-0", which should be adequate for most cranes with lift capacities up to 200 tons. The profile of haul roads above ground shall be at least 12". If the haul roads are to be constructed in a floodplain, the haul road profile shall be at least 12" above the 5-year storm event water surface elevation. The Designer shall seek additional guidance during field reviews from the Headquarters Construction Office and Regional Operations staff to determine the location and appropriate size of the haul roads. It is recommended to limit extending haul roads more than 25' along a stream top of bank.

TDOT ROADWAY DESIGN GUIDELINES
CHAPTER 2 GEOMETRIC DESIGN CRITERIA

English

Revised: 04/24/23

2-601.02 HAUL ROAD COMPENSATION

The cost of supplying and placing all materials for the initial construction of the haul road and cost for removal of the haul road shall be paid under Item Number 203-50 Construction of Haul Road and the unit of measure shall be Lump Sum. The cost for constructing the haul road includes the following items:

- Geotextile (Type IV)(Stabilization)
- ¹Borrow Excavation (Graded Solid Rock)
- ¹Machined Rip-Rap (Class A-1)
- ¹Machined Rip Rap (Class B)
- ¹Machined Rip Rap (Class C)
- ²Mineral Aggregate (Size 57)
- Temporary Drainage Pipe – May not be necessary on all haul roads

¹ If the haul road is constructed in a dry or unsaturated area, Borrow Excavation (graded solid rock) shall be used. If the haul road is constructed in water or in an area within the flood plain, Machined Rip-Rap (Class A-1, Class B, or, Class C) shall be used in place of Borrow Excavation.

² An additional ten (10) percent for Mineral Aggregate is included in Item 203-50. The additional ten (10) percent is for the maintenance of the haul road due to inclement weather events outside the contractor's control.

Item Number 203-50 shall be footnoted as shown below in the Roadway Estimated Quantities sheet:

FOOTNOTE:

ITEM NUMBER 203-50 SHALL INCLUDE GEOTEXTILE (TYPE IV), BORROW EXCAVATION (GRADED SOLID ROCK) OR MACHINED RIP-RAP (CLASS A-1, CLASS B, OR CLASS C), MINERAL AGGREGATE (SIZE 57), AND TEMPORARY DRAINAGE PIPE (IF APPLICABLE). THE MINERAL AGGREGATE INCLUDES AN ADDITIONAL TEN (10) PERCENT FOR MAINTENANCE.

Any item numbers needed for stabilization of the area due to the removal of the haul road shall be paid for separately.

TDOT ROADWAY DESIGN GUIDELINES
CHAPTER 2 GEOMETRIC DESIGN CRITERIA

English

Revised: 04/24/23

2-601.03 HAUL ROAD TYPICAL SECTION

The following haul road typical section (see *Figure 2-21, Haul Road Typical Section*) shall be shown and labeled with the appropriate width and depth based on the anticipated function and loads. The typical section shall be revised accordingly for haul roads constructed in a floodplain. The note shall also be shown.

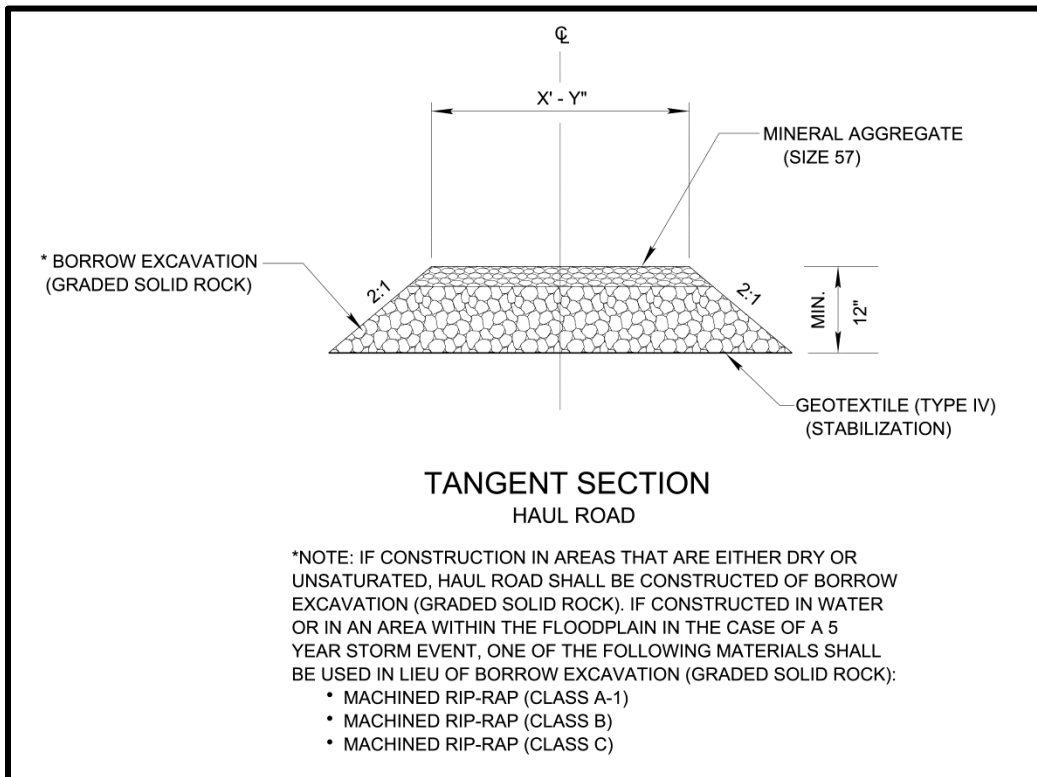

Figure 2-21
Haul Road Typical Section

Any changes to the haul road typical section in the field shall be approved by the Regional Operations Engineer. The Regional Operations Engineer shall request a revision from the Designer. The Designer shall check with the Regional Environmental Tech Group to determine if the permit needs to be modified due to the typical section revision.

TDOT ROADWAY DESIGN GUIDELINES
CHAPTER 2 GEOMETRIC DESIGN CRITERIA

English

Revised: 04/24/23

SECTION 7 – EARTHWORK DESIGN

2-700.00 EARTHWORK CONSIDERATIONS

The earthwork design is dependent on all the other roadway design elements, such as horizontal alignment, vertical alignment, roadway cross section, etc. The designer must use good engineering judgement to achieve an appropriate balance between all these elements to provide a final roadway design that meets all the constraints for a particular project. One of the major tasks in roadway construction is removing and placing earth materials to achieve the desired earth grade cross-section. The Designer should define where the roadway material is to be obtained, where it will be placed, and the amount of material to be excavated, etc. when developing plans. This section will discuss information that should be taken into consideration when a Designer is calculating earthwork and trying to balance their job.

The geotechnical report and geotechnical related drawings should be consulted by the Roadway Designer to determine what type of materials will be encountered during excavation and embankment construction for a project. The geotechnical report should provide enough information to determine the type materials described below and project specific recommendations for shrink and swell factors. It is recommended that the Designer contact the Geotechnical Engineering Section (TDOT.Geotech@tn.gov) of the Materials and Test Division as needed to clarify any questions arising regarding the nature of materials to be encountered and accounted for in the grading tabulations and bid quantities.

The following terms and definitions will be used by all TDOT Divisions so that a consistent definition is used in all phases of project development and in contract documents. Guidance to Designers as to the material breakdown to be shown on the plans and cross-sections should be found in the geotechnical report.

A. SOIL MATERIAL

Soil material is material that is predominantly made up of naturally occurring mineral particles which are fairly readily separated into relatively small pieces, and in which the mass may contain air, water, or organic materials. This material may contain rock pieces in the form of disconnected slabs, lenses, or boulders of less than approximately 0.5 cubic yards. The main soil groups consist of clay, silt, sand, gravel, cobbles, boulders (less than 0.5 cubic yard volume) or a combination of any of the constituents. For construction purposes, this material would typically be considered to be excavatable by conventional excavation machinery such as pans, track hoes, or front-end excavators/loaders. This material would have a shrink factor as given in the shrink factors shown in Section 2-405.05, Shrinkage and Swell Factors, of the Design Guidelines or as recommended by the Geotechnical Engineering Section of the Materials and Tests Division.

B. SOLID ROCK MATERIAL

Solid rock material is that naturally occurring material composed of mineral particles so firmly bonded together that relatively great effort is required to separate the particles (i.e. blasting or heavy crushing forces). For construction purposes, this material would typically have to be blasted to separate into pieces small enough to

TDOT ROADWAY DESIGN GUIDELINES
CHAPTER 2 GEOMETRIC DESIGN CRITERIA

English

Revised: 04/24/23

load and transport on earth moving trucks and which when subjected to proper pre-split and production blasting would result in a uniform stable rock cut face. Note that this material would not by definition necessarily be a proven source of any rock type aggregate such as solid rock, graded solid rock, rip rap, or other rock aggregate construction products. This material would have a significant swell factor as given in swell factors shown in *Section 2-405.05, Shrinkage and Swell Factors*, of the Design Guidelines or as recommended by the Geotechnical Engineering Section of the Materials and Tests Division.

C. SOFT ROCK OR DEGRADABLE ROCK

This material is that naturally occurring material composed of mineral particles that are so firmly bonded such that they are not fairly readily separated into small pieces yet has such relatively low bonding strength that would allow for separating into small pieces through moderate to heavy crushing forces. For construction purposes this material would have to be subjected to ripping type equipment, hoe rams, or rugged use of a large bulldozer in order to separate the material such that it can be readily loaded into earth moving trucks. These materials would typically be shales, claystones, siltstones, weathered sandstones, weathered schist and weathered gneiss. This material would have a relatively small shrink or swell factor depending on the type material and the degree of weathering, disintegration, or degradation.

D. TRANSITIONAL MATERIALS

This material is that material comprised of a combination of soil and rock (Materials A, B, and C as defined above) occurring in either non-uniform interbedded layers of the above materials (i.e. shale material with relatively thin layers of solid rock such as hard limestone) or erratic localized changes of material types both laterally and with depth (such as a geologic formation resulting in pinnacled rock columns, floating boulders or lenses intercalated with clay soil, a common occurrence in certain regions of Tennessee). For construction purposes, this material may have to be excavated using a combination of excavation methods such as blasting of rock pinnacles, layers or boulders along with a ripping of weathered rock and excavating of soil with track hoes or loaders all within a localized area. This material would not be suitable for the use of excavating pan type equipment.

E. COMMON EXCAVATION

Common excavation is that sum of materials excavated from a project inclusive of all those materials described in **A**, **C**, and **D** above. The grouping of these materials is to generally define those materials that would not generally be acceptable to permanently place on a pre-split, blasted face and also to define those materials that would not be considered a source of a defined fill material such as solid rock fill, graded solid rock, rip rap or other rock type aggregates. Typically the materials in this grouping would have either a shrink factor or a relatively low swell factor as compared to solid rock material described in B above.

F. UNCLASSIFIED EXCAVATION

Unclassified excavation is that sum of materials excavated from a project inclusive of all those items described in **A**, **B**, **C**, and **D** above. On most projects, road and drainage excavation will be listed as unclassified and is to be bid as one item

TDOT ROADWAY DESIGN GUIDELINES
CHAPTER 2 GEOMETRIC DESIGN CRITERIA

English

Revised: 04/24/23

regardless of the type material encountered. See Section 203.02(a) of the Standard Specifications for Road and Bridge Construction.

2-701.00 EARTHWORK BALANCES ON WIDENING OF EXISTING ROADWAYS

When balancing the earthwork on a project that involves a grade change on the existing roadway, attention needs to be paid to the construction sequencing. It is not possible to maintain traffic on the existing roadway and, at the same time, use material from that roadway to lower the grade, or conversely, to add material to raise the grade of the existing roadway.

When the Designer considers the need to stockpile material, detour traffic, or maintain traffic by other means, this shall be detailed in the traffic control plans, earthwork balances, or elsewhere as deemed appropriate.

When widening symmetrically along the existing roadway, please request HQ Geotech to core the existing roadway pavement to ensure that the pavement structure is adequate for the widening if additional measures and/or full depth replacement of the existing pavement is needed to meet the needs of the 20 year design.

2-702.00 SHRINKAGE AND SWELL FACTORS

Although the recommended shrink and swell factors to be used for each project are to be requested from the Geotechnical Engineering Section, below is some general guidance. Shrinkage and swell of earth and rock material vary with types of material, weather conditions, equipment used, depth of cuts and fills, and length of haul. Table 2-7, *Shrink and Swell Factors* are examples and are offered as a guide.

TDOT ROADWAY DESIGN GUIDELINES
CHAPTER 2 GEOMETRIC DESIGN CRITERIA

English

Revised: 04/24/23

Light Cut and Fills	
1 – 2 foot cut and fills	Earth 30% to 50% Chert 20% to 30%
2 – 4 foot cut and fills	Earth 25% to 30% Chert 10% to 15%
4-6 foot cut and fills	Earth 15% to 20% Chert 8% to 12%
Heavy Cut and Fills	Earth 10% Chert 0% to 8%
Heavy Cuts and Light Fills	
Cuts 12 feet+, Fills 1 - 2 feet (average)	Earth 15% to 20% Chert 5% to 10%
Cuts 12 feet+, Fills 2 – 4 feet (average)	Earth 10% to 15% Chert 5% to 10%
Shale and Slate	5% to 10% shrinkage; varies with type of material
Sandstone	0% shrinkage to 15% swell; varies with type of material and weather conditions
Limestone	If material is a small percentage and mixed with embankment, 0% shrinkage Heavy cuts and fills: 15% to 20% swell Light fills: 20% swell
Light work through wooded areas call for heavier shrinkage.	
Do not call for rock to be placed in fills less than 3 feet in height unless requested by the Geotechnical Engineering Section.	

Table 2-7
Shrink and Swell Factors

2-703.00 GRADING LINE THROUGH SOLID ROCK

Do not show a solid rock grading line on the typical sections. Specifications for excavation of rock at the subgrade and where rock slopes are to be seeded are covered in the [TDOT Standard Specifications for Road and Bridge Construction](#).

TDOT ROADWAY DESIGN GUIDELINES
CHAPTER 2 GEOMETRIC DESIGN CRITERIA

English

Revised: 04/24/23

2-704.00 PRESPLITTING OF ROCK EXCAVATION

On all projects having rock excavation, a quantity shall be included for pre-splitting the rock at the outside limits of the cut areas containing the rock. Pre-splitting shall not be required on slopes flatter than 1:1 as per Section 203 of the Standard Specifications.

The quantity of pre-splitting shall be computed from the roadway cross-sections and paid for under Item Number 203-01.11 Presplitting of Rock Excavation per S.Y. or Item Number 203-01.12 Oriented Presplitting of Rock Excavation per S.Y.

2-705.00 CAPPING ROCK FILLS

In areas where a solid rock fill is expected and grassed slopes are designed, provide road and drainage excavation (unclassified) or borrow excavation (unclassified) in sufficient quantity to cap these fills with a minimum of ± 9 inches of common material before placing topsoil and seeding.

2-706.00 EARTHWORK BALANCES IN PLANS

Earthwork balances shall be computed using average end areas. Examples of how to calculate earthwork balances are as follows:

1. Calculation procedure for balanced Earthwork.

250,000 C.Y.	Exc. (Common)
-13,000 C.Y.	Topsoil from exc. Areas
<u>- 5,000 C.Y.</u>	Topsoil from emb. Areas
232,000 C.Y.	Exc. (Common) available for balance

$\frac{\text{Exc. (Com)}}{1.15} + [\text{Exc. (Rock)} \times 1.15]$	vs. Emb.
$\frac{232,000}{1.15} + (45,000 \times 1.15)$	vs. 253,489 C.Y.
201,739 + 51,750	vs. 253,489 C.Y.
253,489 C.Y.	= 253,489 C.Y.

2. Calculation procedure for unbalanced Earthwork.

350,000 C.Y.	Exc. (Common)
--------------	---------------

TDOT ROADWAY DESIGN GUIDELINES
CHAPTER 2 GEOMETRIC DESIGN CRITERIA

English

Revised: 04/24/23

-13,000 C.Y. Topsoil from exc. Areas
- 5,000 C.Y. Topsoil for emb. Area
332,000 C.Y. Exc. (Common) available for balance

$$\frac{\text{Exc. (Com)}}{1.15} + [\text{Exc. (Rock)} \times 1.15] \text{ vs. Emb.}$$
$$\frac{332,000}{1.15} + (45,000 \times 1.15) \text{ vs. } 253,489 \text{ C.Y.}$$
$$340,446 \text{ C.Y. vs. } 253,489 \text{ C.Y.}$$

The 86,957 C.Y. of excess material has had the shrinkage factor applied to it (this assumes all excess material will be common). When this quantity is multiplied by the shrinkage factor (to "un-shrink" it), the excess then becomes 100,000 C.Y.

2-707.00 TOPSOIL REQUIREMENTS FOR EARTHWORK BALANCES

In areas to be seeded or sodded, compute the quantity of topsoil required based on a 3-inch ± thickness with 100% shrinkage.

A note shall be added to the plans below the earthwork tabulation block detailing any special areas where topsoil will not be required (such as rock fills not to be seeded). Include topsoil and seeding quantities for sodded or paved ditch areas on projects requiring topsoil and seeded slopes.

Topsoil shall be secured from within the proposed roadway balances where possible. If necessary, embankment areas shall be stripped in addition to excavation areas.

When final earthwork balances are calculated, the topsoil shall be taken into account in the following manner:

1. Calculate the topsoil needed and the topsoil available to see if all the topsoil can possibly be obtained from the proposed roadway areas.
2. Adjust the cross-section end areas as necessary to reflect the topsoil that is to be stripped. These adjusted areas are to be used to balance the job.
3. Balance the project using the proper shrinkage and swell factors.
4. Include the topsoil on the estimated grading quantities tabulated block.

If no topsoil can be secured from the project area to accommodate seeding/sodding, include Item Number 203-07 Furnishing & Spreading Topsoil per C.Y. in the estimated quantities.

TDOT ROADWAY DESIGN GUIDELINES
CHAPTER 2 GEOMETRIC DESIGN CRITERIA

English

Revised: 04/24/23

If adequate topsoil can be secured from the project area to accommodate seeding/sodding, include Item Number 203-04 Placing and Spreading Topsoil per C.Y. in the estimated quantities.

If adequate topsoil cannot be secured from the project area to accommodate seeding/sodding, include Item Number 203-04 Placing and Spreading Topsoil per C.Y. and Item Number 203-07 Furnishing & Spreading Topsoil per C.Y. in the estimated quantities.

Using the example in Section 2-707.00, *Earthwork Balances in Plans*, a total of 18,000 C.Y. of topsoil has been stripped from the project area. According to the [TDOT Standard Specifications for Road and Bridge Construction](#), payment for stripping and stockpiling of topsoil shall be paid for under Item Number 203-01, Road & Drainage Excavation (Unclassified). Given the 100% shrinkage factor, when placing and spreading topsoil, the thickness used in calculations should be 6" since the final thickness needs to be 3".

For example, 18,000 C.Y. of topsoil spread 6" thick will cover 22.31 acres. This will be paid for under Item Number 203-04, Placing and Spreading Topsoil, per C.Y. If the project area that needs topsoil is greater than 22.31 acres, then the additional topsoil will be paid for under Item Number 203-07, Furnishing & Spreading Topsoil.

2-708.00 ESTIMATED GRADING QUANTITIES TABULATED BLOCK

The Estimated Grading Quantities tabulated block should be shown on Sheet 2E, Tabulated Quantities Sheet. An example of the tabulated block is shown in *Table 2-8, Estimated Grading Quantities – Balanced Example* and *Table 2-9, Estimated Grading Quantities – Unbalanced Example*.

On all projects using Item No. 203-01, Road and Drainage Excavation (Unclassified), it is to be referred to as unclassified excavation. When the Designer has received the Soils and Geology Report stating approximately what portion is common and what portion is solid rock, the Designer is to include the quantities in the block, even if the quantity is zero. If the Designer does not know the composition of the material being excavated, the Designer should use write 'UNKNOWN' in the Rock cell.

TDOT ROADWAY DESIGN GUIDELINES
CHAPTER 2 GEOMETRIC DESIGN CRITERIA

English

Revised: 04/24/23

ESTIMATED GRADING QUANTITIES						
DESCRIPTION	UNADJUSTED VOLUMES (CY)		ADJUSTED VOLUMES (CY)	BALANCE SUMMARY		
	EXC.	EMB.	EXC.	SHRINK = 15 % SWELL = 15 %		
MAINLINE	219500	243000	190870	EXC. EMB. 253490 VS -253490 AVAILABLE = 0 WASTE MATERIAL = 0		
SIDE ROADS	12500	5490	10870			
PVT. DRIVES, BUSINESS AND FIELD ENTRANCES	0	0				
INDEPENDENT DITCHES	0	0				
TEMPORARY CONSTRUCTION EXITS	0	0				
OTHER	0	0				
PAVEMENT	0					
TOPSOIL (EMB.)	5000		4348			
TOPSOIL (EXC.)	13000		11305			
TOPSOIL (TO REPLACE STRIPPED TOPSOIL)		5000				
ROCK (C.Y.)	TOTALS (C.Y.)					
EXC. EMB.	EXC. (UNCL.)	EMB. (UNCL.)	EXC (COMMON)	EXC. (AVAIL.)	EXC. (ADJ.)	
45000 0	250000	253490	232000	201740	253490	

Table 2-8
Estimated Grading Quantities – Balanced Example

ESTIMATED GRADING QUANTITIES						
DESCRIPTION	UNADJUSTED VOLUMES (CY)		ADJUSTED VOLUMES (CY)	BALANCE SUMMARY		
	EXC.	EMB.	EXC.	SHRINK = 15 % SWELL = 15 %		
MAINLINE	319500	243000	277827	EXC. EMB. 340446 VS -253490 AVAILABLE = 86956 WASTE MATERIAL = 100000		
SIDE ROADS	12500	5490	10870			
PVT. DRIVES, BUSINESS AND FIELD ENTRANCES						
INDEPENDENT DITCHES						
TEMPORARY CONSTRUCTION EXITS						
OTHER						
PAVEMENT						
TOPSOIL (EMB.)	5000		4348			
TOPSOIL (EXC.)	13000		11305			
TOPSOIL (TO REPLACE STRIPPED TOPSOIL)		5000				
ROCK (C.Y.)	TOTALS (C.Y.)					
EXC. EMB.	EXC. (UNCL.)	EMB. (UNCL.)	EXC (COMMON)	EXC. (AVAIL.)	EXC. (ADJ.)	
45000 0	350000	253490	332000	288696	340446	

Table 2-9
Estimated Grading Quantities – Unbalanced Example

TDOT ROADWAY DESIGN GUIDELINES
CHAPTER 2 GEOMETRIC DESIGN CRITERIA

English

Revised: 04/24/23

2-709.00 GRADING REPORT

All grading report sheets shall show the federal and/or state project numbers, route numbers and/or street names and county on each sheet. The Designer should use the [Grading Report template](#). Each sheet shall be numbered to reflect both the individual sheet number as well as the total number of quantity sheets in the submission. See *Figure 2-22, Sample Grading Report*.

GRADING REPORT									
COMPUTED BY: AMY LORENTZ					SHEET 1 OF 1				
CHECKED BY: DAWN PRUETT					STATE NO.:83027-3221-94				
PIN: 124717.00					FEDERAL PROJECT NO: BR-STP-174(27)				
ROUTE NO. OR STREET: SR 174					COUNTY: SUMNER				
ESTIMATED GRADING QUANTITIES									
DESCRIPTION	UNADJUSTED VOLUME \$ (CY)			ADJUSTED VOLUME \$ (CY)			BALANCE SUMMARY		
	EXC.	EMB.		EXC.	EMB.		SHRINK = 20 %	SWELL = 20 %	
MAINLINE	4236	6578		3529					
SIDE ROADS	2341	654		1951					
PVT. DRIVES, BUSINESS AND FIELD ENTRANCES							EXC.	EMB.	
PAVEMENT	542			452			16883	VS.	-7232
TOPSOIL (EMB.)							AVAILABLE =		9651
TOPSOIL (EXC.)							WASTE MATERIAL =		11581
TOPSOIL (TO REPLACE STRIPPED TOPSOIL)									
TOTALS (C.Y.)									
ROCK	EXC. (UNCL.)	EMB. (UNCL.)	EXC. (COMMON)	EXC. (AVAIL)	EXC. (ADJ.)				
543	7118	7232	6576	5480	16883				

***** SR 174 *****									
Material Name	End Areas	Unadjusted	Adjusted	Mult	Mass	Accum	Accum	Accum	Accum
Station		(sq. ft.)	Volumes (cu. yd.)	Volumes (cu. yd.)	Factor	Ordinate	Unadj Vol (cu. yd.)	Adj Vol (cu. yd.)	
100+43.56 EARTH									
Excavation		20	0	0	0.85		0	0	
Fill		0	0	0	1.00	0	0	0	
100+50.00 EARTH									
Excavation		22	5	4	0.85		5	4	
Fill		0	0	0	1.00	4	0	0	
100+75.00 EARTH									
Excavation		51	34	29	0.85		39	33	
Fill		0	0	0	1.00	33	0	0	
101+00.00 EARTH									
Excavation		117	78	66	0.85		117	99	
Fill		0	0	0	1.00	99	0	0	
101+25.00 EARTH									
Excavation		185	140	119	0.85		257	218	
Fill		0	0	0	1.00	218	0	0	

Figure 2-22
Sample Grading Quantities Sheet

SECTION 8 – TRUCK CLIMBING LANES

2-800.00 TRUCK CLIMBING LANE DESIGN

It is desirable to provide a truck-climbing lane as an added lane for the upgrade direction of a highway where the grade, traffic volumes and heavy-vehicle volumes combine to degrade traffic operations from those on the approach to grade. This section discusses guidelines for determining the location of truck-climbing lanes, critical lengths of grade, design criteria for truck-climbing lanes and guidance on how to develop truck speed profiles. For additional guidance on these topics, see *AASHTO A Policy on Geometric Design of Highways and Streets*.

2-800.01 LOCATION GUIDELINES

A truck-climbing lane may be necessary to allow a specific upgrade to operate at an acceptable level of service. The following criteria will apply:

Two-Lane Highways – On a two-lane, two-way highway, a truck-climbing lane should be considered if the following conditions are satisfied:

- The upgrade traffic flow is in excess of 200 veh/h; and
- The heavy-vehicle volume (i.e., trucks, buses and recreational vehicles) exceeds 20 veh/h during the design hour; and

One of the following conditions exists:

- The critical length of grade is exceeded for the 10 mph speed reduction curve (see *Figure 2-23, Critical Length of Grade for Design*), or
- The level of service (LOS) on the upgrade is E or F, or
- There is a reduction of two or more LOS when moving from the approach segment to the upgrade; or
- The construction costs and the construction impacts (e.g., environmental, right-of-way) are considered reasonable.

Multi-lane Highways – A truck-climbing lane should be considered on a multi-lane highway if the following conditions are satisfied:

- The directional service volume for LOS D is exceeded on the upgrade; and
- The directional service volume exceeds 1000 veh/h/lane; and
- One of the following conditions exists:

TDOT ROADWAY DESIGN GUIDELINES
CHAPTER 2 GEOMETRIC DESIGN CRITERIA

English

Revised: 04/24/23

- The critical length of grade is exceeded for the 10 mph speed reduction curve (see *Figure 2-23, Critical Length of Grade for Design*), or
- The LOS on the upgrade is E or F, or
- There is a reduction of one or more LOS when moving from the approach segment to the upgrade; and
- The construction costs and the construction impacts (e.g., environmental, right-of-way) are considered reasonably.

Also, truck-climbing lanes should be considered where the above criteria are not met and if there is an adverse crash experience on the upgrade related to slow-moving heavy vehicles.

2-800.02 CAPACITY ANALYSIS

See the [Highway Capacity Manual 2016](#) for guidance on conducting capacity analyses for climbing lanes on two-lane and multi-lane highways.

2-800.03 CRITICAL LENGTH OF GRADE

The critical length of grade is the maximum length of a specific upgrade on which a truck can operate without an unreasonable reduction in speed. The highway gradient, in combination with the length of the grade, will determine the truck speed reduction on upgrades.

The following will apply to the critical length of grade:

1. Design Vehicle – *Figure 2-23, Critical Length of Grade for Design*, presents the critical length of grade for a 200 lb/hp truck. This vehicle is representative of size and type of a heavy vehicle normally used for design on main roads.
2. Criteria – *Figure 2-23, Critical Length of Grade for Design*, provides the critical lengths of grade for a given percent grade and acceptable truck speed reduction. Although these curves are based on an initial truck speed of 70 mph, they apply to any design or posted speed. For design purposes, use the 10 mph speed reduction curve in the figure to determine if the critical length of grade is exceeded.
3. Momentum Grades – Where an upgrade is preceded by a downgrade, trucks will often increase their speed to ascend the upgrade. A speed increase of 5 mph on moderate downgrades (3%-5%) and 10 mph on steeper downgrades (6%-8%) of sufficient length are reasonable adjustments to the initial speed. This assumption allows the use of a higher speed reduction curve in *Figure 2-23, Critical Length of Grade for Design*. However, the Designer should also consider that these speed increases may not always be attainable. If traffic volumes are sufficiently high, a truck may be behind another vehicle when descending the momentum grade, thereby restricting the increase in speed. Therefore, only consider these increases in speed if the highway has a LOS C or better.
4. Measurement – Vertical curves are part of the length of grade. *Figure 2-24, Measurement for Length of Grade*, illustrates how to measure the length of grade to

TDOT ROADWAY DESIGN GUIDELINES
CHAPTER 2 GEOMETRIC DESIGN CRITERIA

English

Revised: 04/24/23

determine the critical length of grade using *Figure 2-23, Critical Length of Grade for Design*.

5. Application – If the critical length of grade is exceeded, flatten the grade, if practical, or evaluate the need for a truck-climbing lane. Typically, only two-lane highways have operational problems that require truck-climbing lanes.

TDOT ROADWAY DESIGN GUIDELINES
CHAPTER 2 GEOMETRIC DESIGN CRITERIA

English

Revised: 04/24/23

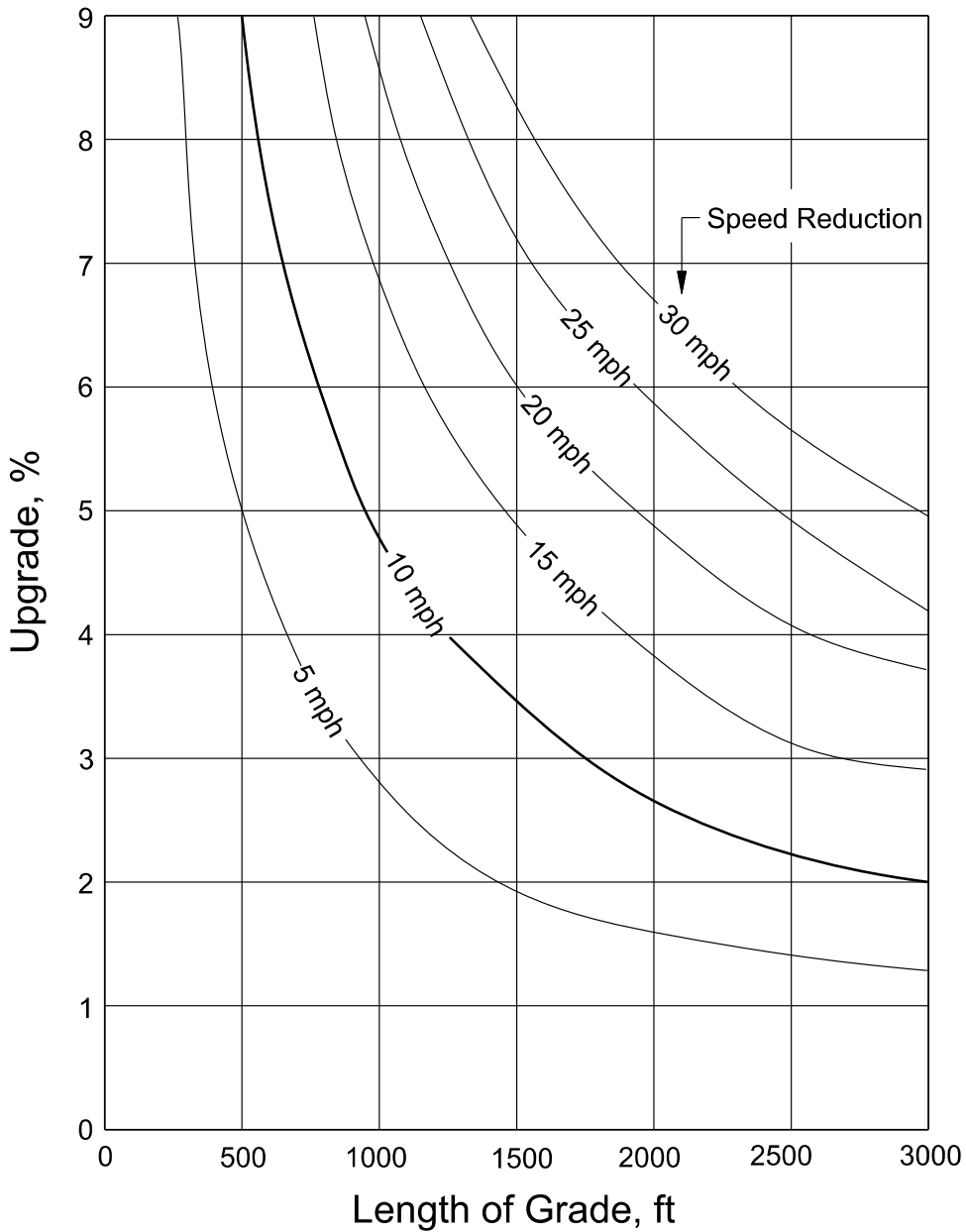

Notes:

1. Typically, the 10 mph curve will be used.
2. Figure is based on a truck with initial speed of 70 mph. However, it may be used for any design or posted speed.
3. This figure is based on a 200 lb/hp heavy vehicle.
4. Figure is from the AASHTO A Policy on Geometric Design of Highways and Streets.

Figure 2-23
Critical Length of Grade for Design

TDOT ROADWAY DESIGN GUIDELINES
CHAPTER 2 GEOMETRIC DESIGN CRITERIA

English

Revised: 04/24/23

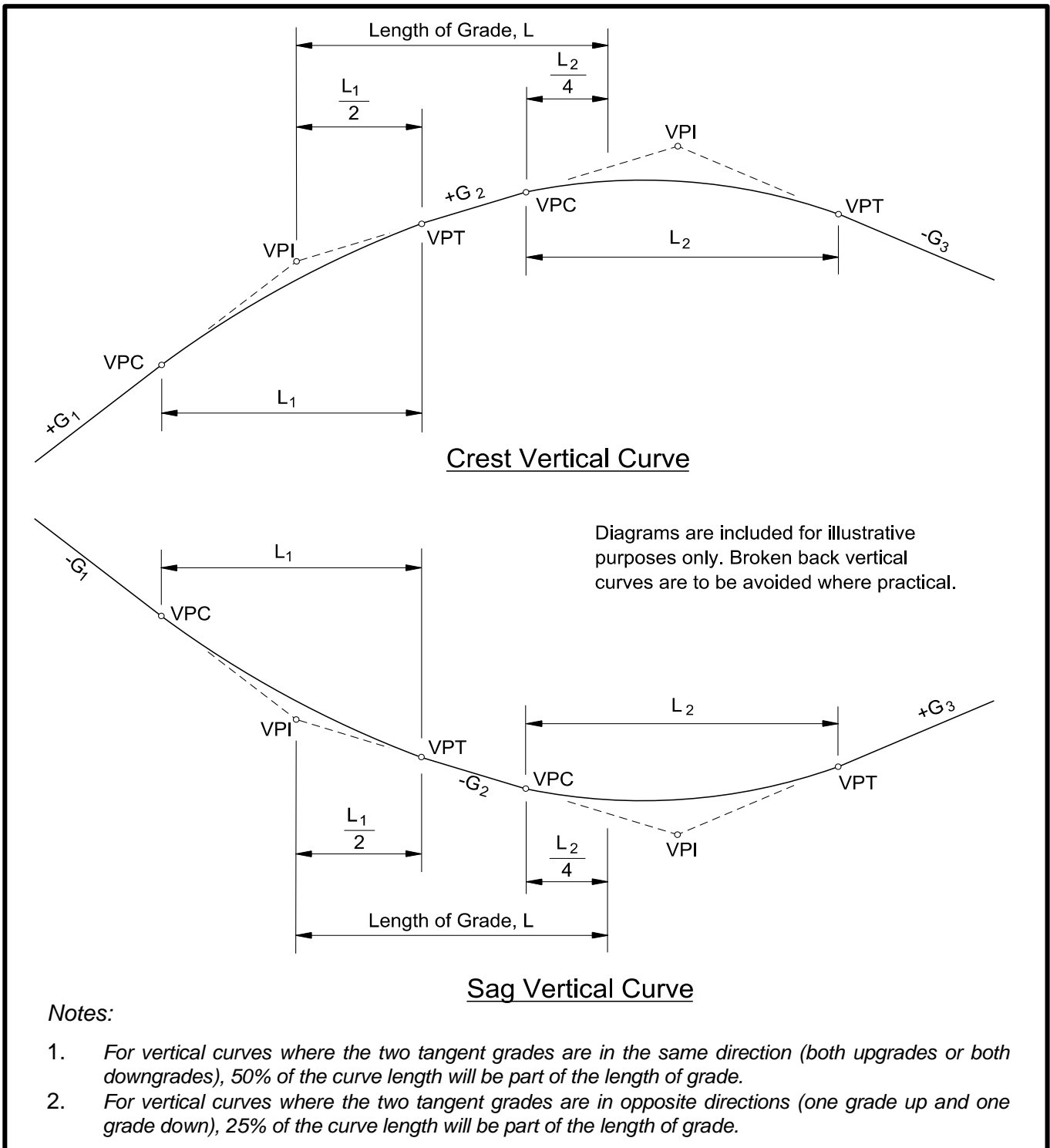

Figure 2-24
Measurement for Length of Grade

TDOT ROADWAY DESIGN GUIDELINES
CHAPTER 2 GEOMETRIC DESIGN CRITERIA

English

Revised: 04/24/23

Highway Types – The critical-length-of-grade criteria applies equally to two-lane or multi-lane highways, and applies equally to urban and rural facilities.

Alternative Critical Lengths of Grades – In many design situations, *Figure 2-23, Critical Length of Grade for Design*, may not be directly applicable to the determination of the critical length of grade for one of following reasons:

- The truck population for a given site may be such that a weight/power ratio is either less than or greater than the 200 lb/hp design vehicle (e.g., coal mining trucks, gravel trucks).
- The truck speed at the entrance to the grade may differ from the 70 mph assumed in *Figure 2-23, Critical Length of Grade for Design*.
- The profile may not consist of a constant percent grade.

For these situations, the Designer may want to consider using the software program Truck Speed Profile Model (TSPM) described in [NCHRP Report 505 Review of Truck Characteristics as Factors in Roadway Design](#) to determine the applicable critical length of grade. This program may be used to generate speed truck profiles for any specified truck weight/power ratio, initial truck speed, and sequence of grades.

Example Problems – Examples No. 1 and No. 2 illustrate the use of *Figure 2-23, Critical Length of Grade for Design*, to determine the critical length of grade. Example No. 3 illustrates the use of *Figure 2-23, Critical Length of Grade for Design*, and *Figure 2-24, Measurement for Length of Grade*. In the examples, the use of subscripts 1, 2, etc., indicate the successive gradients and lengths of grade on the highway segment.

Example No. 1

Given: Level Approach
G = +4%
L = 1500 ft (length of grade)
Rural Principal Arterial

Problem: Determine if the critical length of grade is exceeded.

Solution: *Figure 2-23, Critical Length of Grade for Design*, yields a critical length of grade of 1200 ft for a 10-mph speed reduction. The length of grade (L) exceeds this value. Therefore, flatten the grade, if practical, or evaluate the need for a truck-climbing lane.

Example No. 2

Given: Level Approach
G₁ = +4.5%
L₁ = 500 ft
G₂ = +2%

TDOT ROADWAY DESIGN GUIDELINES
CHAPTER 2 GEOMETRIC DESIGN CRITERIA

English

Revised: 04/24/23

$$L_2 = 700 \text{ ft}$$

Rural Arterial with a significant number of heavy trucks

Problem: Determine if the critical length of grade is exceeded for the combination of grades G_1 and G_2 .

Solution: From *Figure 2-23, Critical Length of Grade for Design*, G_1 yields a truck speed reduction of 5 mph. G_2 yields a speed reduction of approximately 3 mph. The total of 8 mph is less than the maximum 10 mph speed reduction. Therefore, the critical length of grade is not exceeded.

Example No. 3

Given: *Figure 2-25. Critical Length of Grade Calculations*, illustrates the vertical alignment on a low-volume, two-lane rural collector highway with no large trucks.

Problem: Determine if the critical length of grade is exceeded for G_2 or for the combination upgrade G_3 and G_4 .

Solution: Use the following steps:

Step 1: Determine the length of grade using the criteria in *Figure 2-25. Critical Length of Grade Calculations*. For this example, the following calculations are used:

$$L_2 = \frac{1000}{4} + 600 + \frac{800}{4} = 1050\text{ft}$$

$$L_3 = \frac{800}{4} + 700 + \frac{400}{2} = 1100\text{ft}$$

$$L_4 = \frac{400}{2} + 300 + \frac{600}{4} = 650\text{ft}$$

Step 2.: Determine the critical length of grade in both directions. Use *Figure 2-23, Critical Length of Grade for Design*, to determine the critical length of grade.

- For trucks traveling left to right, enter into *Figure 2-23, Critical Length of Grade for Design*, the value for G_3 (3.5%) and $L_3 = 1100$ ft. The speed reduction is 7.0 mph. For G_4 (2%) and $L_4 = 650$ ft., the speed reduction is approximately 3.5 mph. The total speed reduction on the combination upgrade G_3 and G_4 is 10.5 mph. This exceeds the maximum 10 mph speed reduction. However, on low-volume roads, one can assume a 5 mph increase in truck speed for the 3% “momentum” grade (G_2), which precedes G_3 . Therefore, a speed reduction may be as high as 15 mph before concluding that the combination grade exceeds the critical length of grade. Assuming the benefits of the momentum grade, this leads to the conclusion that the critical length of grade is not exceeded.
- For trucks traveling in the opposite direction, on *Figure 2-23, Critical Length of Grade for Design*, enter in the value for G_2 (3%) and determine the critical length

TDOT ROADWAY DESIGN GUIDELINES
CHAPTER 2 GEOMETRIC DESIGN CRITERIA

English

Revised: 04/24/23

of grade for the 10 mph speed reduction (i.e., 1700 ft). Because L_2 is less than 1700 ft (i.e., 1050 ft), the critical length of grade for this direction is not exceeded.

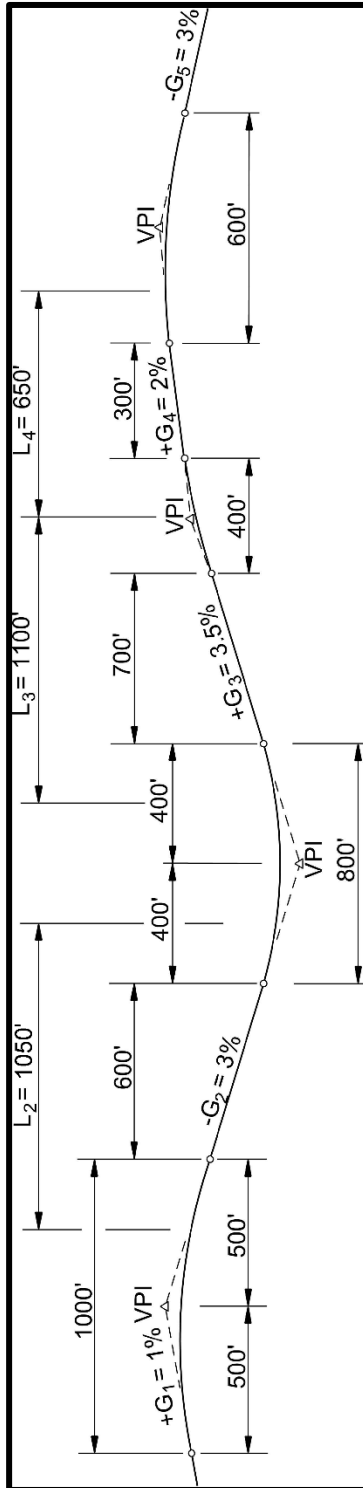

Figure 2-25
Critical Length Of Grade Calculations
(Example No. 3)

TDOT ROADWAY DESIGN GUIDELINES
CHAPTER 2 GEOMETRIC DESIGN CRITERIA

English

Revised: 04/24/23

2-800.04 DESIGN CRITERIA

Table 2-10, *Design Criteria for Truck-Climbing Lanes*, summarizes the design criteria for a truck-climbing lane. Also, consider the following:

1. Design Speed – For entering speeds equal to or greater than 70 mph, use 70 mph for the truck design speed. For speeds less than 70 mph, use the roadway design speed or the posted speed limit, whichever is less. Under restricted conditions, the Designer may want to consider the effect a momentum grade will have on the entering speed. See Section 2-800.03 for additional information on momentum grades. However, the maximum speed will be 70 mph.
2. Cross Slope – On tangent sections, refer to RD11-SE-1 for cross slope information on the truck-climbing lanes.
3. Superelevation – For horizontal curves, superelevate the truck-climbing lane at the same rate as the adjacent travel lane.
4. Performance Curves – *Figure 2-26, Performance Curves for Trucks*, presents the deceleration and acceleration rates for a 200 lb/hp truck.
5. End of Full-Width Lane – In addition to the criteria in Table 2-10, *Design Criteria for Truck-Climbing Lanes*, ensure that there is sufficient sight distance available to the point where the truck, RV, or bus will begin to merge back into the through travel lane. At a minimum, this will be stopping sight distance. Desirably, the driver should have decision sight distance available to the roadway surface (i.e., height of object = 0.0 ft.) at the end of the taper. See the AASHTO *A Policy on Geometric Design of Highways and Streets* for decision sight distance values.

The full-lane width should be extended beyond the crest vertical curve and not ended just beyond the crest of the grade. Desirably the full-lane width should not end on a horizontal curve.

6. Signing and Pavement Markings – Contact the Regional Project Delivery Signing Designer for signing and pavement marking guidance for truck-climbing lanes.

TDOT ROADWAY DESIGN GUIDELINES
CHAPTER 2 GEOMETRIC DESIGN CRITERIA

English

Revised: 04/24/23

Design Element	Desirable	Minimum
Lane Width	12 ft	Width of adjacent lane
Shoulder Width	Same width as approach shoulder	Interstate: 6 ft Other Highways: 4 ft
Cross Slope on Tangent	0.02 ft/ft	0.02 ft/ft
Beginning of Full-Width Lane ⁽¹⁾	Location where the truck speed has been reduced to 10 mph below the posted speed limit	Location where the truck speed has been reduced to 45 mph
End of Full-Width Lane ⁽²⁾	Location where truck has reached highway posted speed or 55 mph, whichever is less	Location where truck has reached 10 mph below highway posted speed limit
Entering Taper	25:1	300 ft
Exiting Taper	Interstate: 70:1 Other Highways: 600 ft	50:1
Minimum Full-Width Length	1000 ft or greater	Interstate Only: 1000 ft

Table 2-10
Design Criteria for Truck-Climbing Lanes

Notes:

1. Use Figure 2-26, Performance Curves for Trucks to determine truck deceleration rates. In determining the applicable truck speed, the Designer may consider the effect of momentum grades.

3. Use Figure 2-26, Performance Curves for Trucks to determine truck acceleration rates. Also, see Comment 5 in [Section 2-800.03](#).

TDOT ROADWAY DESIGN GUIDELINES
CHAPTER 2 GEOMETRIC DESIGN CRITERIA

English

Revised: 04/24/23

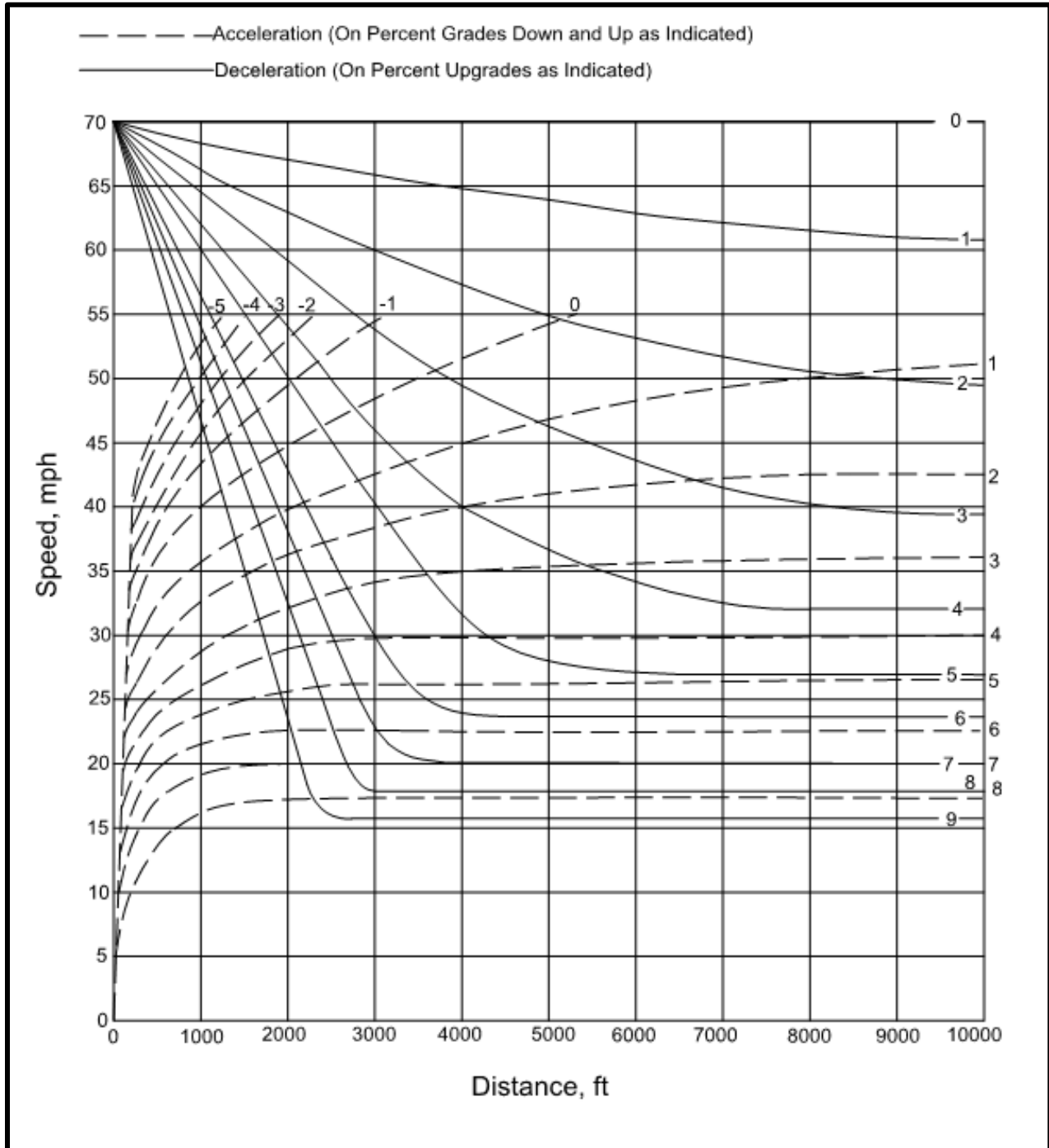

Notes:

1. For entering speeds equal to or greater than 70 mph, use an initial speed of 70 mph. For speeds less than 70 mph, use the design speed or posted speed limit as the initial speed.
2. Figure is from the AASHTO A Policy on Geometric Design of Highways and Streets.

Figure 2-26
Performance Curves for Trucks (200 lb/hp)

TDOT ROADWAY DESIGN GUIDELINES
CHAPTER 2 GEOMETRIC DESIGN CRITERIA

English

Revised: 04/24/23

2-800.05 DOWNGRADES

Truck lanes on downgrades are not typically considered. However, steep downhill grades may also have a detrimental effect on the capacity and safety of facilities with high traffic volumes and numerous heavy trucks. Although specific criteria have not been established for these conditions, trucks descending steep downgrades in low gear may produce nearly as great an effect on operations as an equivalent upgrade. The need for a truck lane for downhill traffic will be considered on a site-by-site basis.

2-800.06 TRUCK SPEED PROFILE

For highways with a single grade, the critical length of grade and deceleration and acceleration rates can be directly determined from *Figure 2-26, Performance Curves for Trucks*. However, most highways have a continuous series of grades. Often, it is necessary to find the impact of a series of significant grades in succession. If several different grades are present, then a speed profile may need to be developed. The following example illustrates how to construct a truck speed profile and how to use *Figure 2-26, Performance Curves for Trucks*.

Example No. 4

Given: Level Approach
 $G_1 = +3\%$ for 800 ft (VPI to VPI)
 $G_2 = +5\%$ for 3200 ft (VPI to VPI)
 $G_3 = -2\%$ beyond the composite upgrade (G_1 and G_2)
 $V = 60$ mph design speed with a 55 mph posted speed limit
 Rural Principal Arterial

Problem: Using the criteria in Table 2-10, *Design Criteria for Truck-Climbing Lanes*, and *Figure 2-26, Performance Curves for Trucks*, construct a truck speed profile and determine the beginning and ending points of the full-width climbing lane.

Solution: Apply the following steps:

Step 1: Determine the truck speed on G_1 using, *Figure 2-26, Performance Curves for Trucks*, and plot the truck speed at 200 ft increments. Assume an initial truck speed of 55 mph. Move horizontally along the 55 mph line to the 3% deceleration curve. This is approximately 2800 ft along the horizontal axis. This is the starting point for G_1 .

TDOT ROADWAY DESIGN GUIDELINES
CHAPTER 2 GEOMETRIC DESIGN CRITERIA

English

Revised: 04/24/23

Figure 2-27 Distance From VPI₁ (ft)	Horizontal Distance on Figure 2-26 (ft)	Truck Speed (mph)	Comments
0	2800	55	VPI ₁
200	3000	54	
400	3200	53	
600	3400	52	
800	3600	51	VPI ₂

Table 2-11
Truck Speed on G₁

TDOT ROADWAY DESIGN GUIDELINES
CHAPTER 2 GEOMETRIC DESIGN CRITERIA

English

Revised: 04/24/23

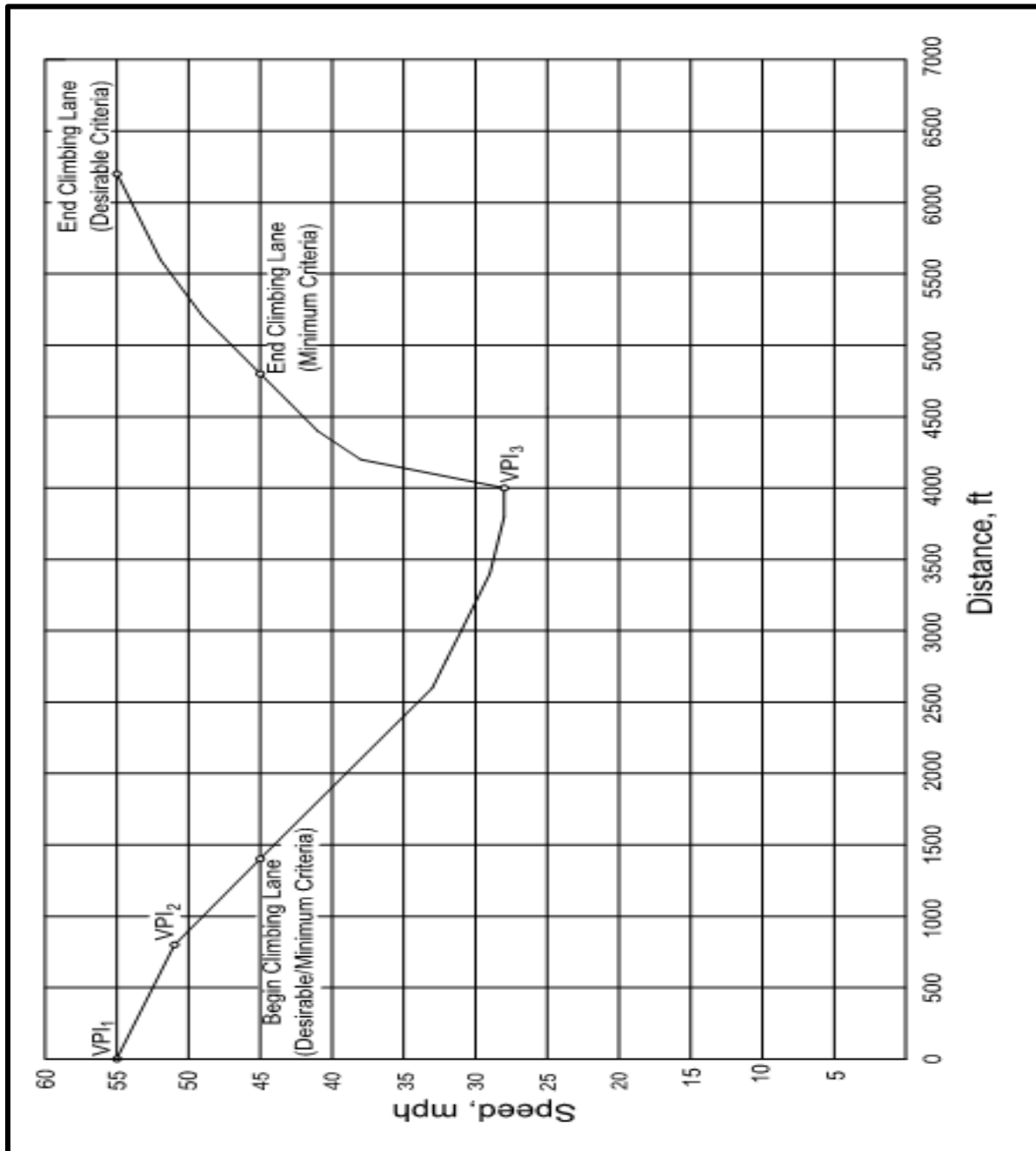

Step 2: Determine the truck speed on G_2 using *Figure 2-26, Performance Curves for Trucks* and plot the truck speed at 200 ft. increments in *Figure 2-27, Truck Speed Profile*. From Step 1, the initial speed on G_2 is the final speed from G_1 (i.e., 51 mph). Move right horizontally along the 51 mph line to the 5% deceleration curve. This is approximately 1900 ft. along the horizontal axis. This is the starting point for G_2 .

TDOT ROADWAY DESIGN GUIDELINES
CHAPTER 2 GEOMETRIC DESIGN CRITERIA

English

Revised: 04/24/23

Figure 2-27 Distance From VPI ₁ (ft)	Horizontal Distance on Figure 2-26 (ft)	Truck Speed (mph)	Comments
800	1900	51	VPI ₂
1000	2100	49	
1200	2300	47	
1400	2500	45	
1600	2700	43	
1800	2900	41	
2000	3100	39	
2200	3300	37	
2400	3500	35	
2600	3700	33	
2800	3900	32	
3000	4100	31	
3200	4300	30	
3400	4500	29	
3600	4700	29	
3800	4900	28	
4000	5100	28	VPI ₃

Table 2-12
Truck Speed on G₂

Step 3: Determine the truck speed on G₃ using *Figure 2-26, Performance Curves for Trucks*, until the truck has fully accelerated to 55 mph, and plot the truck speed at 200 ft. increments in *Figure 2-27, Truck Speed Profile*. The truck will have a speed of 28 mph as it enters the 2% downgrade at VPI₃. Read into *Figure 2-26, Performance Curves for Trucks*, at the 28 mph point on the vertical axis and move over horizontally to the - 2% line. This is approximately 150 ft. along the horizontal axis. This is the starting point for G₃.

TDOT ROADWAY DESIGN GUIDELINES
CHAPTER 2 GEOMETRIC DESIGN CRITERIA

English

Revised: 04/24/23

Figure 2-27 Distance From VPI ₁ (ft)	Horizontal Distance on Figure 2-26 (ft)	Truck Speed (mph)	Comments
4000	150	28	VPI ₃
4200	350	38	
4400	550	41	
4600	750	43	
4800	950	45	
5000	1150	47	
5200	1350	49	
5400	1550	50	
5600	1750	52	
5800	1950	53	
6000	2150	54	
6200	2350	55	

Table 2-13
Truck Speed on G₃

Step 4: Determine the beginning and end of the full-width climbing lane. From Table 2-10, *Design Criteria for Truck-Climbing Lanes*, the desirable and minimum beginning of the full-width lane will be where the truck has reached a speed of 45 mph (10 mph below the posted speed). This point occurs 1400 ft. beyond VPI₁.

For ending the full-width climbing lane, the desirable criterion from Table 2-10, *Design Criteria for Truck-Climbing Lanes*, is where the truck speed has reached the posted speed limit (55 mph) or 6200 ft. beyond the VPI₁. The minimum criterion is where the truck has reached a speed of 45 mph (10 mph below the posted speed). This occurs at 4800 ft. beyond VPI₁.

TDOT ROADWAY DESIGN GUIDELINES
CHAPTER 2 GEOMETRIC DESIGN CRITERIA

English

Revised: 04/24/23

SECTION 9 – RETAINING WALL DESIGN

2-900.00 RETAINING WALLS

During the development of many roadway design projects, a retaining wall is proposed due to right-of-way limitations, environmental impacts, drainage issues, or the need to reduce damage to adjacent properties. The development of a retaining wall involves TDOT personnel including Project Development, Structures, and the Geotechnical Engineering Section of the Materials and Tests Division. A consultant may also serve as the Designer in place of Project Development and/or Structures personnel. When biological, environmental, hazardous materials, historical, or archeological factors are involved, it shall be necessary to coordinate with the Environmental Division to ensure the affected area is properly identified and protected.

The following sections will define the role each TDOT Division has in designing retaining walls, the steps needed to create retaining wall sheets, and which sheets are mandatory for field reviews and plan submittals.

2-900.01 RETAINING WALL SHEET NAMES, NUMBER, AND ORDER IN PLANS

All Retaining Wall Detail Sheets shall be designated as an “R” series. Refer to Chapter One of the Roadway Design Guidelines for information on the correct placement of the sheets in the index and plan sets for R.O.W. and Construction projects.

NOTE: Sheets with retaining wall information shall no longer be part of the Roadway “2” series sheets in construction plans.

The following series of sheets shall be used for each retaining wall:

1. Retaining Wall (R)

The sheet title block shall be named: Retaining Wall Estimated Quantities

The sheet number will be *R.sht, RA.sht, RB.sht, etc.*

These sheet(s) shall be provided by the Structures Division and Geotechnical Engineering Section and include the quantities for all retaining walls.

2. Retaining Wall (R#)

The sheet title block shall be named: Retaining Wall (R#) Geotechnical Design Notes and Requirements

The sheet number will be *R1.sht, R2.sht, R3.sht, etc.*

TDOT ROADWAY DESIGN GUIDELINES
CHAPTER 2 GEOMETRIC DESIGN CRITERIA

English

Revised: 04/24/23

These sheet(s) shall be provided by the Structure Division and Geotechnical Engineering Section.

3. Retaining Wall (R#A)

The sheet title block shall be named: Retaining Wall (R#A) Geometric Layout

The sheet number will be *R1A.sht, R2A.sht, R3A.sht, etc.*

These sheet(s) shall be provided by the Designer.

4. Retaining Wall (R#B)

The sheet title block shall be named: Retaining Wall (R#B) Soil Profiles and Details

The sheet number will be *R1B.sht, R2B.sht, R3B.sht, etc.*

These sheet(s) shall be provided by the Structures Division and Geotechnical Engineering Section.

If additional sheets are needed, the following naming format will be used:

5. Retaining Wall (R#C, R#D, etc.)

If there is additional information needed for a wall that falls outside the normal sheet titles as shown in previous numbers 1-4, this sheet series can be used and named as needed by Structures or Geotechnical.

The sheet title block shall be named: Retaining Wall (R#C) XXXXXXXX

The sheet number will be *R1C.sht, R2C.sht, R3C.sht, etc.*

These sheet(s) shall be provided by the Structures Division and Geotechnical Engineering Section.

The following is an example of the retaining wall portion of the R.O.W. Index for a project with three retaining walls where the additional sheet (R#C) was not needed.

RETAINING WALL DETAILS..... R1-R3B

The order of sheets in the plans shall be the following:

R1, R1A, R1B, R2, R2A, R2B, R3, R3A, and R3B.

The following is an example of the retaining wall portion of the Construction Index for a project with three retaining walls where the additional sheet (R#C) was not needed.

RETAINING WALL ESTIMATE AND DETAILS.....*R,R1-R3B

The order of sheets in the plans shall be the following:

*R, R1, R1A, R1B, R2, R2A, R2B, R3, R3A, and R3B.

*Note that the Retaining Wall Estimates, sheet (R) is only in the construction plan set.

TDOT ROADWAY DESIGN GUIDELINES
CHAPTER 2 GEOMETRIC DESIGN CRITERIA

English

Revised: 04/24/23

2-900.02 DEVELOP THE RETAINING WALL GEOMETRIC LAYOUT SHEET

During preliminary plans development, the Designer shall determine if a retaining wall shall be considered. When it is, **Steps 1- 4** shall be followed to develop the *Retaining Wall (R#A) Geometric Layout* sheet, often referred to as the conceptual drawing.

STEP 1: PREPARE THE PLAN, PROFILE, AND CROSS SECTION SHEETS

The following sheets in the roadway plans shall include the proposed retaining wall(s):

Present Layout Sheet: The Designer shall show the retaining wall on the present sheet. The station and offset for beginning, ending, and all breakpoints along the wall shall be labeled.

Proposed Layout Sheet: The Designer shall show the retaining wall on the proposed sheet. The station and offset for beginning, ending, and all breakpoints along the wall shall be labeled.

Profile Sheet: The Designer shall show a profile view of the top and bottom of the wall. The bottom of the wall shall be 2' below the ground line. The station and elevation for beginning, ending, and all breakpoints along the wall shall be labeled.

Cross Sections: The Designer shall display the centerline of the retaining wall in the cross sections. The Present R.O.W. limits and Proposed R.O.W. limits shall also be displayed onto the cross sections. For walls that are 100' or greater in length, cross sections shall be cut at the beginning and end stations of the wall, at **50'** station increments along the wall, and additional cross sections at 10' increments 50' prior to the beginning and 50' after the end of the wall. This will aid the Structures Division in determining the exact location of the beginning and ending stations of the wall. For retaining walls less than 100' in length, cross sections shall be cut at the beginning and end stations of the wall, at **10'** station increments along the wall, and additional cross sections at 10' increments 50' prior to the beginning and 50' after the end of the wall. These cross sections will be submitted in the **nnnnnn-nn-RetainingWall.zip** file but shall not be part of the R.O.W. or Construction .zip submittal. These cross sections shall remain in the Designer's files for information purposes only.

TDOT ROADWAY DESIGN GUIDELINES
CHAPTER 2 GEOMETRIC DESIGN CRITERIA

English

Revised: 04/24/23

STEP 2: PREPARE THE RETAINING WALL (R#A) GEOMETRIC LAYOUT SHEET

In addition to sheets in the roadway plans, a Retaining Wall Detail Geometric Layout Sheet, as shown in *Figure 2-28, Example Retaining Wall Detail Geometric Layout Sheet*, shall be developed by the Designer for each proposed retaining wall that includes the retaining wall Plan View, Profile View, and Typical Section details.

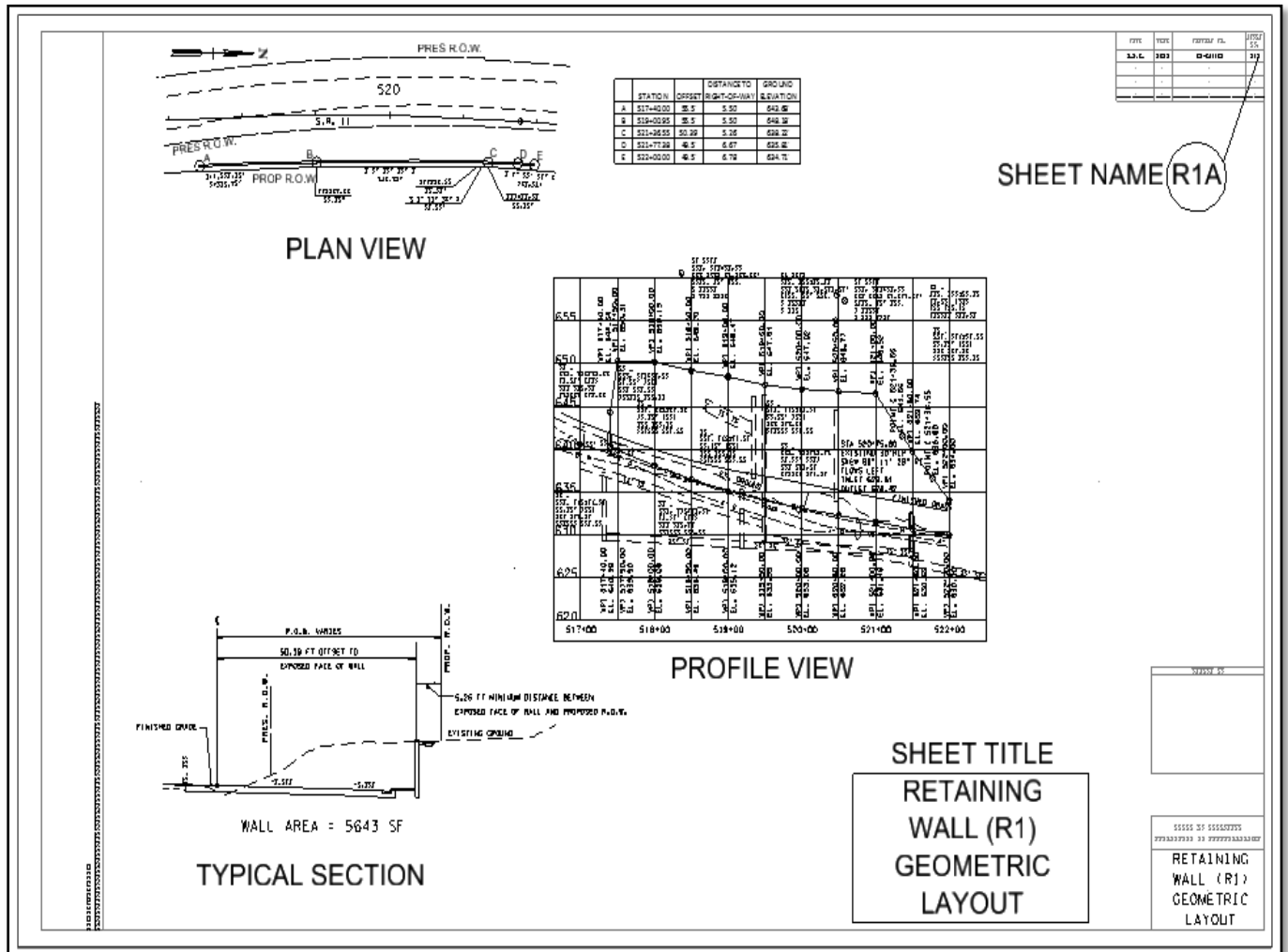

Figure 2-28
Example Retaining Wall Detail Geometric Layout Sheet

TDOT ROADWAY DESIGN GUIDELINES
CHAPTER 2 GEOMETRIC DESIGN CRITERIA

English

Revised: 04/24/23

Plan View: The Designer shall show the proposed layout of the retaining wall relative to the roadway centerline and Present and Proposed R.O.W. boundaries. All Proposed R.O.W. and/or easements shall be labeled. The layout shall show an alphabetical representation for the beginning, ending, and all breakpoints along the length of the wall. A chart shall be shown representing each of these points by stations based on the proposed centerline, offsets from proposed centerline to the exposed face of wall, distances between the exposed face of wall and Proposed R.O.W., and the ground elevations at the center of the wall. (Assume wall thickness is 1').

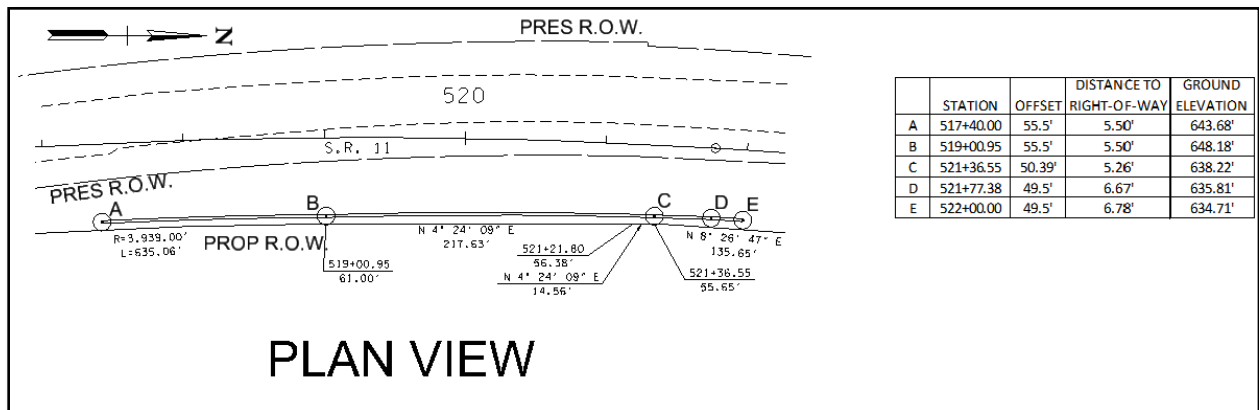

Figure 2-29
Example Retaining Wall Plan View

For clarity, the plan view used for the Retaining Wall (R#A) Geometric Layout Sheet shall not show any other features. The present and the proposed layout sheets shall have the retaining wall shown with additional features (existing and proposed utilities (if available), drainage structures, etc.).

Profile View: The Designer shall show a profile view of the top and bottom of the wall. The bottom of the wall shall be 2' below the ground line (this depth may change after review by the Structures Division). The stations and elevations for beginning, ending, and all breakpoints along the wall shall be labeled. The corresponding Points as shown in the Plan View shall also be shown in the profile. For this example, only Points C and D needed to be added. Because Point B at Sta. 519+00.95 was within 1' of the VPI at Sta. 519+00.00, the elevation was the same; thus, the point did not need to be labeled.

TDOT ROADWAY DESIGN GUIDELINES
CHAPTER 2 GEOMETRIC DESIGN CRITERIA

English

Revised: 04/24/23

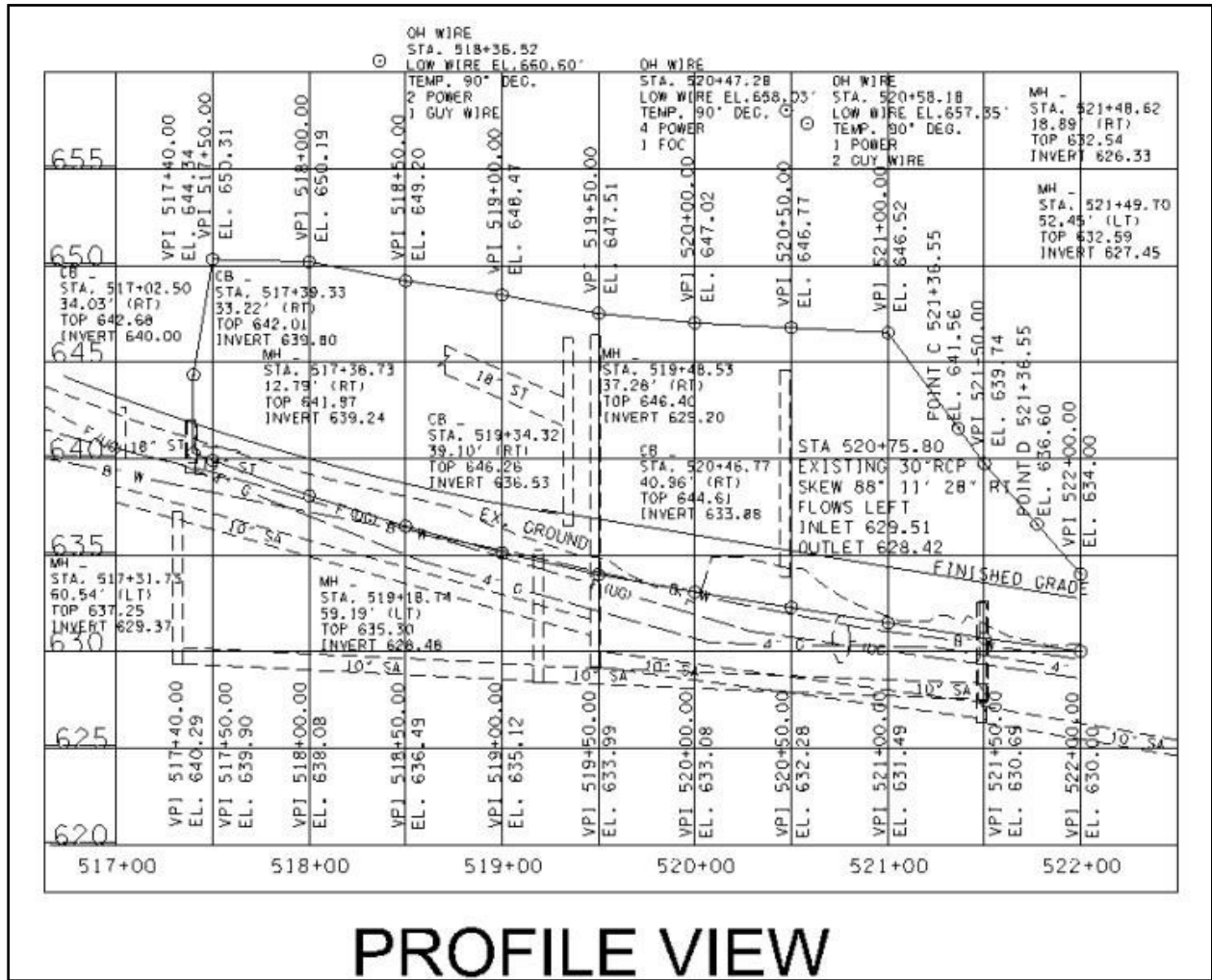

PROFILE VIEW

Figure 2-30
Example Retaining Wall Profile View

The example profile view displays existing drainage, utilities, etc. The designer shall make the decision to display additional features (existing and proposed utilities (if available), drainage structures, etc.) as long as clarity is not an issue. The profile sheet in the plans shall show all of these features.

Typical Section: The Designer shall show a typical section of the retaining wall. The chart shown in Plan View represents all stations and offsets for the beginning, ending, and all breakpoints along the wall. A typical section shall be shown at the station where the minimum distance between the exposed face of the wall and the Proposed R.O.W. occurs. For this example, the minimum distance (5.26') occurs at Sta. 521+36.55, Point "C". The Present and Proposed R.O.W. lines shall be shown and labeled with the distance between the centerline and Proposed R.O.W. labeled as "R.O.W. Varies" or as a defined distance for areas with fixed R.O.W. width. Slope and

TDOT ROADWAY DESIGN GUIDELINES
CHAPTER 2 GEOMETRIC DESIGN CRITERIA

English

Revised: 04/24/23

construction easements shall be shown and labeled if applicable. The offset from the roadway centerline to the exposed face of the retaining wall shall be labeled. The offset does not include wall thickness. **Note the location of the exposed face of the wall in a cut section.** The square footage of the wall shall be shown if applicable.

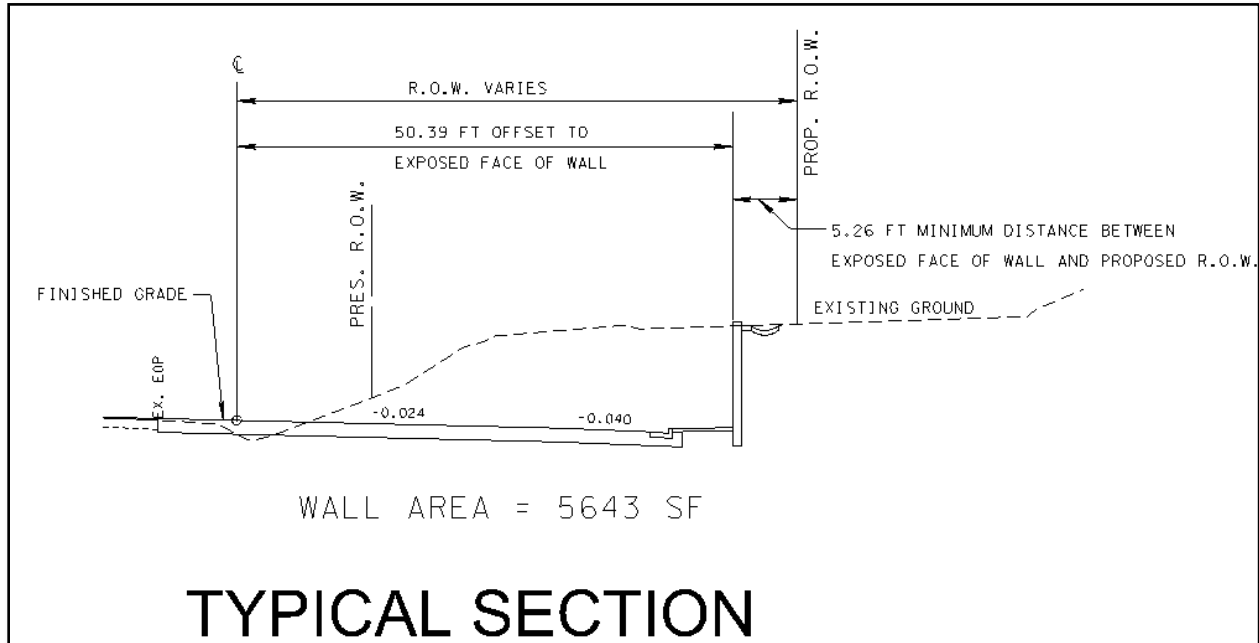

Figure 2-31
Example of Retaining Wall Typical Sections for Cut Section

The examples of walls shown in Fill and Cut Sections, see *Figure 2-32, Example of Retaining Wall Typical Sections for Fill Section* and *Figure 2-31, Example of Retaining Wall Typical Sections for Cut Section*. The typical section shall be shown to represent the section of the wall with the minimum distance between the exposed face of the wall and the Proposed R.O.W. The Present and Proposed R.O.W. lines shall be displayed and labeled with the distance between the centerline and Proposed R.O.W. labeled as "R.O.W. Varies" or as a defined distance for areas with fixed R.O.W. width. The offset from the roadway centerline to the exposed face of the retaining wall shall be labeled. **Note the location of the exposed face of the wall in a fill section.** The square footage of the wall shall also be shown, if applicable.

TDOT ROADWAY DESIGN GUIDELINES
CHAPTER 2 GEOMETRIC DESIGN CRITERIA

English

Revised: 04/24/23

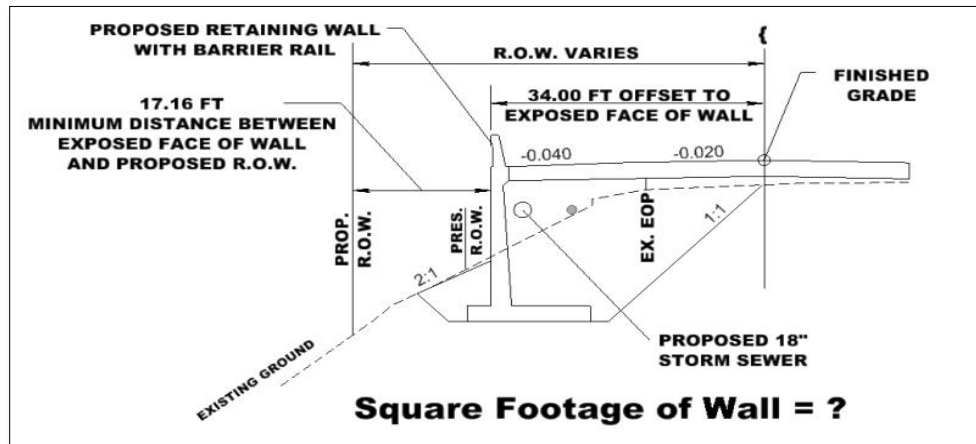

Figure 2-32
Example of Retaining Wall Typical Sections for Fill Section

See Roadway and Pavement Appurtenances - Wall Series Roadway Design Standard Drawings for additional information including retaining wall type restrictions on wall types that cannot be built within available ROW limits.

STEP 3: FILENET ARCHIVING

The Designer or Consultant Manager shall place the following files in a compressed file and place it on FileNet with the name:

nnnnnn-nn-Retainingwall.zip

- Roadway plan sheets including present, proposed, profile ,and cross-section as defined in Step 1(.tin and .gpk files)
- Survey, Proposed and Alignment Files, and cross sections cut at intervals as defined in Step 1
- Retaining Wall (R#A) Geometric Layout Sheet as defined in Step 2(.dgn)
- Retaining Wall Design Letter as shown in Step 4 (.docx)

STEP 4: RETAINING WALL DESIGN LETTER

The Project Development Manager shall email the Proposed Retaining Wall Design letter (see *Figure 2-33, Example Proposed Retaining Wall Design Letter*, for example) to the Retaining Wall email address of the Structures Division (TDOT.StructuresRW@tn.gov) and CC the Geotechnical Engineering Section (TDOT.Geotech@tn.gov) and the Designer. For projects where the wall crosses over a waterway or connects to a bridge over a waterway, the Hydraulic

TDOT ROADWAY DESIGN GUIDELINES
CHAPTER 2 GEOMETRIC DESIGN CRITERIA

English

Revised: 04/24/23

Section of the Structures Division (TDOT.Structures@tn.gov) shall also be included in the email distribution. Any additional requirements on the wall shall be noted in the letter (such as a barrier system, light and/or signal pole, sign, or ITS features incorporated into the wall). If there is proposed lighting or signals in proximity to the wall, TDOT.TrafficOps.Sign-Reviews@tn.gov and/or TDOT.TrafficOps.SNL-Reviews@tn.gov shall be included in the email distribution. If there is an ITS feature concerning the wall, TDOT.TrafficOps.ITS-Reviews@tn.gov shall be included in the email distribution.

The subject line in the email distribution shall be noted by:

Region X, County Name, Project Description (as shown in PPRM), Federal Project Number, State Project Number, PIN nnnnnn-nn, Retaining Wall Design

The Designer shall archive the Proposed Retaining Wall Design letter on FileNet as part of the zip file (Refer to Step 3: FileNet Archiving).

TDOT ROADWAY DESIGN GUIDELINES
CHAPTER 2 GEOMETRIC DESIGN CRITERIA

English

Revised: 04/24/23



PROPOSED RETAINING WALL DESIGN

TO: Structures Division, TDOT.StructuresRW@tn.gov
FROM: Project Development Manager
DATE: [Click here to enter a date.](#)
SUBJECT: COUNTY:
PIN:
PROJECT NO.
PROJECT DESCRIPTION:

During the development of the subject project, our office determined retaining walls shall be considered. I am requesting the Structures Division coordinate with the Geotechnical Section to evaluate each retaining wall to determine if the retaining wall is a feasible option for locations as shown on the plans and request that they coordinate the acquisition of soil surveys deemed necessary by the structural designer. Please notify our office immediately if a wall is deemed not to be a feasible solution.

The retaining wall information shown on the preliminary plans is conceptual in nature; therefore, any changes to the length, location, or footprint of proposed walls could affect R.O.W. in an already constrained location. Please note the following R.O.W. restrictions, known environmental constraints, or project commitments when determining your design and approved alternatives: (Designer to enter all R.O.W. restrictions, environmental constraints, and/or project commitments for each wall location here)

The *Retaining Wall Detail (R1A.sht, R2A.sht, etc.) Geometric Layout* sheet(s) and related files are on FileNet under the name: *nnnnn-nn-RetainingWall.zip*. For all walls, additional information or changes to all *Retaining Wall Detail (R1A.sht, R2A.sht, etc.) Geometric Layout* sheet(s) pertaining to wall length, location, or footprint of the wall shall be provided to the TDOT Project Development Designer or Consultant Designer by this date [Click here to enter a date.](#) (Designer to enter date three weeks prior to the date scheduled to print for the R.O.W. Field Review).

For each wall **designed** by the Structures Division, the Structures Division shall also provide *Preliminary Retaining Wall Details (R1.sht, R2.sht, etc.) Geotechnical Design Notes* sheet(s) for insertion into the plans for R.O.W. field review by this date [Click here to enter a date.](#) (Designer to enter date one week prior to the date scheduled to print for R.O.W. Field Review distribution). *Retaining Wall Details (R1B.sht, R2B.sht, etc.) Soil Profiles and Details* sheet(s) **shall not** be provided.

For each wall **not designed** by the Structures Division, the *Retaining Wall Details (R1.sht, R2.sht, etc.) Geotechnical Design Notes* and *Retaining Wall Details (R1B.sht, R2B.sht, etc.) Soil Profiles and Details* sheet(s) **shall not** be provided for the R.O.W. Field Review.

This project will have a Design Meeting (PPRM Activity #400) on [Click here to enter a date.](#)

For further information, please contact: _____, Phone: (_____) _____ - _____, Email: _____.

CC: Geotechnical Engineering Section: TDOT.Geotech@tn.gov
Project Delivery Designer (Enter Email)
Or Consultant Designer
Traffic Operations Division:
If plans include ITS Communication TDOT.TrafficOps.ITS-Reviews@tn.gov
If plans include signals and/or lighting TDOT.TrafficOps.SNL-Reviews@tn.gov

Figure 2-33
Example Proposed Retaining Wall Design Letter

TDOT ROADWAY DESIGN GUIDELINES
CHAPTER 2 GEOMETRIC DESIGN CRITERIA

English

Revised: 04/24/23

2-900.03 RETAINING WALL ASSESSMENT AT SITE REVIEW

A Site Review shall be held that occurs between the Preliminary and R.O.W. Field Reviews. The Site Review document is available to download from the [Standard Design CADD Files and Documents](#) webpage.

At the Site Review, the Structures Division and the Geotechnical Engineering Section will analyze all proposed retaining wall(s), ensure there are no other alternatives but to build the wall(s), and use the checklist (Figure 2-34, *Retaining Wall Constructability Check List in Site Review Document*) within the Site Review document to determine if the wall(s) are susceptible to constructability issues:

<p>Retaining Wall Number ____ Road Name/Sta. Range: _____</p> <p>1. Circle all of the following that may apply:</p> <ul style="list-style-type: none">a. The footprint of the wall is within 10' of R.O.W.b. Existing and/or Proposed Utilities (Signal Poles, TVA towers or fixed Structures) are near the footprint of the wallc. Existing and /or Proposed Drainage Structures are near the footprint of the walld. Foundation Improvement for the wall could affect traffic phasinge. This is a Top Down Constructed wall (Soldier Pile\Lagging, Soil Nail)f. This wall is needed to mitigate pyritic materialg. This wall will be greater than 10 feet in heighth. There are 2 or more traffic phases (affect when the wall is built)i. ITS Infrastructure is within 10 feet of the footprint of the wallj. There is a RR adjacent to the wall (RR usually does not want MSE wall)k. The wall is within the clear zonel. The proposed slope in front of the wall is 2:1 or steeper or zero percentm. There are environmental limitations (wetlands near or needs stream relocation, etc.) <p>When 3 or more are circled, the wall will be considered to be susceptible to constructability issues.</p>

Figure 2-34
Retaining Wall Constructability Check List in Site Review Document

TDOT ROADWAY DESIGN GUIDELINES
CHAPTER 2 GEOMETRIC DESIGN CRITERIA

English

Revised: 04/24/23

Once the analysis is complete, the wall is classified into one of these categories:

1. Category One -Retaining walls **WITH** constructability issues
2. Category Two- Retaining walls **WITHOUT** constructability issues

2-900.04 GUIDELINES FOR CATEGORY ONE RETAINING WALLS

For Category One retaining walls with constructability issues, the following guidance shall be used for each wall:

1. The Structures Division or a Structures Consultant **shall design** the wall.
2. The R.O.W. Field Review and R.O.W. plans **shall** contain the (Preliminary) **Retaining Wall (R#) Geotechnical Design Notes and Requirements** sheet(s). These sheets shall be delivered to Project Development by the date noted in the Retaining Wall Design Letter to allow the designer to print for R.O.W. Field Review Distribution. Updates to the sheet(s) as a result of comments from the R.O.W. Field Review shall be completed and returned to Project Development for insertion into R.O.W. plans.
3. The **Retaining Wall (R#) Geotechnical Design Notes and Requirements** sheet(s) shall list **only one** allowable wall type.
4. If there are R.O.W./Easement station ranges that shall remain clear of utilities or there are other restrictions, it shall be noted on the **Retaining Wall (R#) Geotechnical Design Notes and Requirements** sheet(s). Because this sheet is part of the submittal, it is not necessary to add the note to a Project Commitment sheet.
5. If an agreement has been made between the department and a city or county concerning a specific decorative wall finish, Project Development shall notify Structures and Geotech immediately for approval. A note shall be added to the **Retaining Wall (R#) Geotechnical Design Notes and Requirements** sheet(s) and can also be added as a project commitment. [See Section 2-900.06 Decorative Facing on Retaining Walls.](#)
6. The R.O.W. Field Review and R.O.W. plans **shall** contain the **Retaining Wall (R#A) Geometric Layout** sheet(s). The proposed square footage of the wall shall be shown on the sheet. Information for the sheet shall be delivered by the date noted in the Retaining Wall Design Letter to allow Project Development the time necessary to make any changes recommended by the Structures Division.
7. Any R.O.W revisions concerning the retaining wall shall be processed by Project Development with changes to the sheet(s) completed by the appropriate division(s).
8. The Construction Field Review plans shall contain the **Retaining Wall Estimated Quantities (R)** sheet(s), **Retaining Wall (R#) Geotechnical Design Notes and Requirements** sheet(s), **Retaining Wall R#A) Geometric Layout** sheet(s), and the **Retaining Wall (R#B) Soil Profiles and Details** sheet(s) for each wall. Project Development shall request sheets developed by the Structures Division a minimum of two months prior to the print date for Construction Field Review plans distribution. Updates

TDOT ROADWAY DESIGN GUIDELINES
CHAPTER 2 GEOMETRIC DESIGN CRITERIA

English

Revised: 04/24/23

shall be made to the sheet(s) as a result of comments from the Construction Field Review and Constructability Review held by Headquarters Construction and Regional Operations, if applicable. Project Development shall send the updated **Retaining Wall (R#A) Geometric Layout** sheet(s) for each wall to the Structures Division for insertion into the final Construction plans a minimum of two weeks prior to the Construction submittal date and shall not include the sheets in the Roadway plans submittal. The Structures Division shall seal and submit all sheets pertaining to retaining walls at Construction submittal.

9. Value Engineering change proposals shall not be accepted from contractors for category one retaining walls.

2-900.05 GUIDELINES FOR CATEGORY TWO RETAINING WALLS

For Category Two retaining walls without constructability issues, the following guidance shall be used for each wall:

1. The Structures Division **shall not design** the wall.
2. The R.O.W. Field Review and R.O.W. Plans shall contain the **Retaining Wall (R#A) Geometric Layout** sheet(s) only. The proposed square footage of the wall shall be shown on this sheet. Information for the sheet shall be delivered by the date noted in the Retaining Wall Design Letter to allow Project Development the time necessary to make any changes recommended by the Structures Division.
3. **Retaining Wall (R#) Geotechnical Design Notes and Requirements** sheet(s) shall not be completed for R.O.W. Field Review and R.O.W. plans; thus project commitments must be added to the project commitment sheet for the wall if there are R.O.W./easement station ranges that shall remain clear of utilities or other restrictions.
4. **Retaining Wall (R#) Geotechnical Design Notes and Requirements** sheet(s) shall not be completed for R.O.W. Field Review and R.O.W. plans; thus project commitments must be added if an agreement has been made between the department and a city or county concerning a specific decorative wall finish. Project Development shall notify Structures and Geotech immediately for approval. (See [Section 2-900.06 Decorative Facing on Retaining Walls.](#))
5. The Construction Field Review plans shall contain the **Retaining Wall Estimated Quantities (R)** sheet(s), **Retaining Wall (R#) Geotechnical Design Notes and Requirements** sheet(s), **Retaining Wall (R#A) Geometric Layout** sheet(s), and the **Retaining Wall (R#B) Soil Profiles and Details** sheet(s) for each wall. Project Development shall request sheets developed by the Structures Division and the Structure Estimate a minimum of two months prior to the proposed date to print Construction Field Review plans for distribution. Updates shall be made to the sheet(s) as a result of comments from the Construction Field Review.
6. Any project commitments added to the Project commitment sheets for R.O.W. submittal shall be removed and only be shown in the **Retaining Wall (R#) Geotechnical Design Notes and Requirements** sheet(s) to ensure that there is only one note pertaining to the

TDOT ROADWAY DESIGN GUIDELINES
CHAPTER 2 GEOMETRIC DESIGN CRITERIA

English

Revised: 04/24/23

wall and diminish the likelihood of conflicting notes. Structures and Project Development shall work together to ensure that the notes are covered in the correct sheets.

7. Project Development shall send the updated **Retaining Wall (R#A) Geometric Layout** sheet(s) for each wall to the Structures Division for insertion into the final Construction plans a minimum of two weeks prior to the Construction submittal date. This sheet shall not be turned in with the Roadway Plans. The retaining wall shall be designed by the contractor that was awarded the project. Walls designed and constructed by the contractor shall be limited to the approved alternatives for the wall as specified on the **Retaining Wall (R#) Geotechnical Design Notes and Requirements** sheet(s).
8. **See section 2-900.07 Retaining Wall Quantities**

2-900.06 DECORATIVE FACING ON RETAINING WALLS

If the outside entity requests a decorative facing on walls, TDOT shall recommend the acceptable wall types for that finish. The wall finish shall be compatible with the Department's acceptable wall types. However, if the decorative facing is compatible with the acceptable wall type but unique in appearance, the additional cost of the decorative facing shall be paid for by the county/city. An estimate for the additional cost of the decorative facing shall be calculated by the Structures Division. The Project Development Manager and the Structures Manager overseeing the wall design shall contact the Local Programs Development Office at Local.Programs@tn.gov to discuss a potential contract between TDOT and the entity for the additional costs of the decorative finish.

2-900.07 RETAINING WALL QUANTITIES

Accurate retaining wall quantities are necessary when preparing an estimate for the project during the lifetime of the project. Retaining wall quantities must be estimated as early as possible and included in the request for R.O.W. funding. The quantities must also be included in any R.O.W. revisions that include retaining wall quantities.

Project Development shall calculate the following **roadway items** as applicable associated with each retaining wall:

ITEM NUMBER	DESCRIPTION	QUANTITY
620-05	CONCRETE PARAPET WITH STRUCTURAL TUBING	L.F.
620-10	CONCRETE PARAPET WITH PEDESTRIAN RAILING	L.F.
711-05.70	32" SINGLE SLOPE CONCRETE BARRIER WALL	L.F.
711-05.71	51" SINGLE SLOPE CONCRETE BARRIER WALL	L.F.

TDOT ROADWAY DESIGN GUIDELINES
CHAPTER 2 GEOMETRIC DESIGN CRITERIA

English

Revised: 04/24/23

Structures and Geotech personnel shall calculate the quantity for each retaining wall. Each retaining wall shall be paid for separately utilizing Item Numbers 604-07.01 through 604-07.XX, as needed, with quantities calculated in square feet (S.F.).

ITEM NUMBER	DESCRIPTION	QUANTITY
*604-07.01 through 604-07.XX	RETAINING WALL (DESCRIPTION)	S.F.

NOTE: The description shall be filled in with the wall number, beginning and end station, and the location of the wall in reference to the centerline of the associated road, ramp, or side road left (LT) or right (RT).

Example: 604-07.01 RETAINING WALL (R1, STA. 500+00.00 to STA. 502+05.00, LT)

Example: 604-07.02 RETAINING WALL (R2, STA. 603+15.00 to STA. 604+55.00, RT)

The following quantities are **INCLUDED** in the square footage of the wall and shall not be listed as separate pay items:

ITEM NUMBER	DESCRIPTION	QUANTITY
203-40.10	TIE-BACK ANCHORS (SOIL)	L.F.
203-40.11	TIE-BACK ANCHORS (ROCK)	L.F.
203-40.12	TIE-BACK ANCHORS (3-STRAND UNCLASSIFIED)	L.F.
203-40.13	TIE-BACK ANCHORS (4-STRAND UNCLASSIFIED)	L.F.
203-40.14	TIE-BACK ANCHORS (5-STRAND UNCLASSIFIED)	L.F.
203-40.18	TIE-BACK ANCHORS (ABANDONED)	L.F.
604-01.52	CUSTOM ELASTOMERIC FORM LINER	LS
604-04.01	APPLIED TEXTURE FINISH (NEW STRUCTURES)	S.Y.
710-09.01	6" PERFORATED PIPE WITH VERTICAL DRAIN SYSTEM	L.F.

Structures and Geotech personnel shall calculate the foundation quantities associated with each Category 1 retaining wall **only**. For gravity type retaining walls, the Roadway Designer will use standard drawings and associated item numbers. **Foundation Items** for each retaining wall shall be paid for separately and are not included in the square footage of the wall. Foundation items include but are not limited to the following:

ITEM NUMBER	DESCRIPTION	QUANTITY
203-02.01	BORROW EXCAVATION (GRADED SOLID ROCK) (off site)	TON
203-02.02	BORROW EXCAVATION (GRADED SOLID ROCK) (on site)	C.Y.
203-03.01	BORROW EXCAVATION (SELECT MATERIAL)	C.Y.
203-03.05	BORROW EXCAVATION (SELECT MATERIAL)	TON
606-03.03	STEEL PILES (12 INCH)	L.F.

TDOT ROADWAY DESIGN GUIDELINES
CHAPTER 2 GEOMETRIC DESIGN CRITERIA

English

Revised: 04/24/23

606-03.05	STEEL PILES (12 INCH)COLUMN	L.F.
606-04.03	STEEL PILES (14 INCH)	L.F.
606-04.05	STEEL PILES (14 INCH)COLUMN	L.F.
625-02.01 through 625-02.06	DRILLED SHAFT-SOIL (DIA.)	V.F.
625-02.13 through 625-02.18	DRILLED SHAFT-ROCK (DIA.)	V.F.
625-02.25 through 625-02.30	DRILLED SHAFT CASING-PERMANENT (DIA.)	V.F.
625-02.40	DRILLED SHAFT (SH-SCC) CONCRETE	C.Y.
625-02.44	DRILLED SHAFT REINFORCING STEEL	LB.
626-01.01	AGGREGATE FOUNDATION SYSTEMS	L.S.
740-10.04	GEOTEXTILE (TYPE IV)(STABILIZATION)	S.Y.
930-08.26	LOADING TEST (SOIL NAILS)	EACH
Numerous Items	DRILLING	

2-900.08 R.O.W. FUNDING REQUEST AND R.O.W. REVISIONS

Accurate retaining wall quantities are necessary when preparing an estimate for the project. It is essential that the quantities are estimated as early as possible and included in the request for R.O.W. or Utilities Only funding and included in an updated estimate of R.O.W. when revisions to proposed walls occur that affect quantities.

Project Development requests R.O.W. or Utilities Only funding following the R.O.W. field review. All changes in retaining wall quantities as a result from the R.O.W. Field Review shall be addressed prior to requesting funding. An Estimated Roadway Quantity Excel file is included in the R.O.W. funding request submittal package. The Structures Division does not turn in an estimate for the R.O.W. phase; thus, it is essential that the Project Development Manager communicate with the Structures Manager to obtain applicable pay items for each wall to be included in the Estimated Roadway Quantity Excel file. At a minimum, the roadway items pertaining to the wall and square footage of the wall shall be in the Excel file (See [Section 2-900.07 Retaining Wall Quantities](#)). Any other available quantities provided by Structures shall be included in the Excel File.

If there are significant changes, additions, deletions, etc. to the retaining wall(s) after R.O.W. or Utilities Only submittal, a plans revision shall be distributed and shall include an updated Estimated Roadway Quantity Excel file. The Project Development Manager or Designer shall include the updated estimate in the R.O.W. revision email distribution to TDOT.Preliminary.Estimates@tn.gov and TDOT.PDSO@tn.gov. The email shall state that the estimate is updated and refer to the R.O.W. revision letter for additional information. If a proposed

TDOT ROADWAY DESIGN GUIDELINES
CHAPTER 2 GEOMETRIC DESIGN CRITERIA

English

Revised: 04/24/23

retaining wall was considered a Category Two wall in the R.O.W. submittal but becomes a Category One wall during the development of the project, a R.O.W. revision must be distributed with the additional sheets added to the plans.

2-900.09 CONSTRUCTION FIELD REVIEW, SUBMITTAL, AND REVISIONS

Project Development and Structures shall follow the steps as outlined in [Section 2-900.04, Guidelines for Category One Retaining Walls](#) and [Section 2-900.05, Guidelines for Category Two Retaining Walls](#) for both the Construction Field Review and Final Construction plans submittal. Project Development personnel shall ensure that all pay items except those specified as roadway items shall be removed from the Estimated Roadway Quantity Excel File.

If there are significant changes, additions, deletions, etc. to the retaining wall(s) after Construction submittal, a plans revision shall be distributed for sheet *(R) Retaining Wall Estimated Quantities* and shall include an updated Estimated Roadway Quantity Excel file for retaining wall roadway quantities, if applicable.

2-900.10 RETAINING WALL FOOTNOTES ON CONSTRUCTION PLANS

The Designer shall add the following footnote on the Estimated Roadway Quantity sheet for Construction Field Reviews and final Construction plans on all projects that have retaining walls:

1. ALL COST OF BUILDING AND INSTALLING THE RETAINING WALL, INCLUDING FOUNDATION PREPARATION, BACKFILLING, AND EXCAVATION, SHALL BE INCLUDED IN THE SQUARE FOOTAGE COST OF THE RETAINING WALL. QUANTITIES FOR FOUNDATION PREPARATION, BACKFILL, AND EXCAVATION ARE REFLECTED IN THE END AREA CALCULATIONS ON CROSS SECTIONS AND IN GRADING QUANTITY ROADWAY ITEM 203-01, ROAD AND DRAINAGE EXCAVATION (C.Y.). THE DESIGNER HAS NOTED THE PORTION OF THIS QUANTITY FOR THESE ITEMS ON THE PROFILE SHEET XX AND ON THE GRADING QUANTITY TABULATION SHEET. THE PORTION OF THIS QUANTITY HAS BEEN REMOVED FROM ROADWAY ITEM 203-01, ROAD AND DRAINAGE EXCAVATION (C.Y.). FOR FURTHER INFORMATION ON RETAINING WALLS AND QUANTITIES, SEE SHEET(S) *(R, R1, R1A, R1B, R2, R2A, R2B, etc.)*.

If a Concrete Parapet is on one retaining wall, the quantity shall be shown as a roadway item and the following footnote shall be added:

2. CONCRETE PARAPET IS LOCATED ON RETAINING WALL R# AND IS NOT INCLUDED IN THE COST OF THE RETAINING WALL.

If Concrete Parapet is on multiple retaining walls, the quantity shall be shown as a roadway item and the following footnote shall be added:

TDOT ROADWAY DESIGN GUIDELINES
CHAPTER 2 GEOMETRIC DESIGN CRITERIA

English

Revised: 04/24/23

3. CONCRETE PARAPET IS NOT INCLUDED IN THE COST OF THE RETAINING WALL. BREAKDOWN OF CONCRETE PARAPET FOR EACH WALL IS XX L.F. FOR R#, XX L.F. FOR R#, XX L.F. FOR R#, (ETC.)

If Concrete Barrier is on one retaining wall, the quantity shall be shown as a roadway item and the following footnote shall be added:

4. CONCRETE BARRIER IS LOCATED ON RETAINING WALL R# AND IS NOT INCLUDED IN THE COST OF THE RETAINING WALL.

If Concrete Barrier is on multiple retaining walls, the quantity shall be shown as a roadway item and the following footnote shall be added:

5. CONCRETE BARRIER IS NOT INCLUDED IN THE COST OF THE RETAINING WALL. BREAKDOWN OF CONCRETE BARRIER FOR EACH WALL IS XX L.F. FOR R#, XX L.F. FOR R#, XX L.F. FOR R#, (etc.)

2-900.11 RETAINING WALL BARRIER SYSTEM REQUIREMENTS

The Designer shall show proper barrier type associated with the acceptable wall type. See the Roadway and Pavement Appurtenances - Wall Series Roadway of Design Standard Drawings for type and placement of barrier.

Retaining walls in fill sections may require a barrier system due to the drop off. If there is sufficient room, the barrier system should be placed away from the wall. If the only option is to include the barrier as part of the wall, the Designer shall notify the Structures Division.

Retaining walls in cut sections may require a barrier system. Generally, all retaining wall types inside the clear zone require a concrete barrier. If the wall is outside of the clear zone, a retaining wall may not be required unless deemed appropriate by engineering judgment.

TDOT ROADWAY DESIGN GUIDELINES
CHAPTER 2 GEOMETRIC DESIGN CRITERIA

English

Revised: 04/24/23

SECTION 10 - ROUNDABOUT DESIGN

2-1000.00 ROUNDABOUT DESIGN PRINCIPLES

TDOT roundabout designs should consist of either a single lane or multi-lane facility for both urban and rural settings. The design of a roundabout requires balancing the needs of the existing and proposed traffic in a given location with providing intersection control that is efficient and user friendly for the traveling public. The design should provide for reduced and consistent speeds throughout the intersection. This will enhance both safety and operational performance at the intersection.

At a minimum, all TDOT roundabouts should follow these basic design principles:

- Provide a yield at all entry points
- Yield right-of-way to circulating vehicles
- Counterclockwise vehicular traffic passes to the right of the center island
- Splitter islands at all approaches providing channelized approaches
- Entry deflection required to control speed
- Maintain consistent speeds throughout
- Limit pedestrian traffic to designated locations at the approach legs
- Parking and private driveways prohibited within the circulatory roadway
- Provide proper sight distance, marking, signing, and visibility

Roundabout designs are site specific to each individual intersection and should not be considered as a template to be used at other locations. The Designer should be aware that there is not an absolute design for any given site. Each proposed location will require new information and analysis and may contain site specific design issues to overcome during the project development process.

The basis for these roundabout Design Guidelines is the Federal Highway Administration's (FHWA) Report No. FHWA-RD-00-067, [Roundabouts: An Informational Guide](#), dated June 2000. Available on-line, this document is widely considered the most comprehensive guide for planning and designing roundabouts; however, the Designer should not consider this document as the rule book for proper design. Other supplemental information and standards of practice have been adopted for these Design Guidelines.

2-1001.00 GENERAL ROUNDABOUT DESIGN CONSIDERATIONS

2-1001.01 DESIGN SPEED AND DESIGN VEHICLE SELECTION FOR ROUNDABOUTS

A roundabout operates most effectively when the final design results in a desired speed reduction and a consistent speed is maintained throughout the intersection. Design speed is

TDOT ROADWAY DESIGN GUIDELINES
CHAPTER 2 GEOMETRIC DESIGN CRITERIA

English

Revised: 04/24/23

fundamental to attaining desired operational performance at the intersection. The design speed of a roundabout is determined from the fastest vehicle path allowed by the geometry. Geometric and other design features should be properly selected and checked to ensure speeds are appropriately reduced at the approach, entry, circulating lanes, and exit of the intersection. A combination of all design elements working together is ultimately how the final design speed will be dictated. *Table 2-14, Recommended Entry Design Speed (R1) for Roundabouts*, provides the recommended design speed based on the type of roundabout.

Roundabout Type	Recommended Entry Design Speed R1 (mph)
Urban Single Lane	20
Urban Multi-Lane	25
Rural Single Lane	25
Rural Multi-Lane	30

Table 2-14
Recommended Entry Design Speed (R1) for Roundabouts

Reference: FHWA, *Roundabouts: An Informational Guide, 2000*

The choice of design vehicle should be based on the type of roadway, volume and type of vehicles expected, and the intersection location. For the purpose of most TDOT designs, the AASHTO WB-62 vehicle should be used for designing roundabouts, especially those located on the state highway system, freeway or other controlled access facility ramp terminals, or industrial areas where a high percentage of truck traffic is expected. The circulatory roadway width should readily accommodate a WB-50 design vehicle without the need to track onto the truck apron; however, larger vehicles (WB-62, etc...) are expected to track onto the truck apron.

In cases where a roundabout is being located in an area with minimal truck traffic, or where the roundabout is being located on an urban collector, local road, or where community sensitive design parameters are being used for design, the WB-50 design vehicle may be used for the entire design, including the turning movements check at the truck apron. Where over-sized trucks are expected, the Designer may want to consider designing the roundabout for a legal vehicle larger than the WB-62.

The design vehicle should be accommodated while maintaining a minimum 2-foot separation between the truck and the curb face. Additionally, the Designer should be aware that for multi-lane roundabouts, large trucks rarely track within the circulatory lanes marked on the pavement and may utilize both lanes, or possibly both lanes *and* the truck apron, while attempting to navigate through the intersection.

2-1001.02 HORIZONTAL ALIGNMENT CONSIDERATIONS FOR ROUNDABOUTS

All approaching roadway centerlines should pass near the center of the proposed circle, as close to a 90 degree angle as possible when projected across the intersection. This configuration should allow for necessary entry deflection without creating severe horizontal

TDOT ROADWAY DESIGN GUIDELINES
CHAPTER 2 GEOMETRIC DESIGN CRITERIA

English

Revised: 04/24/23

If there is a possibility for future expansion of a roundabout from a single lane to a multi-lane facility, the Designer should consider designing the roundabout to a multi-lane standard with provisions for expanding the initial roundabout included in the design. The intersection may be opened as a single lane roundabout and then enlarged toward the central island and splitter islands at a later date. Expansion should normally be inward, so the Designer should provide an adequately sized inscribed circle diameter and splitter islands if future expansion is expected.

2-1001.05 CONSIDERATIONS FOR HIGH SPEED APPROACHES AND RURAL LOCATIONS FOR ROUNDABOUTS

High speed approaches and rural roundabout locations require additional attention because of the need for speed reduction of the approaching vehicles. Any approach to a roundabout with a posted speed of 45 mph or greater should be considered a high speed approach, even if the project site is located in an urban or urbanizing area. At these locations, drivers may not be anticipating a roundabout or any other type of speed interruption. Drivers should be able to discern the impending intersection configuration and react to changing operational needs. Providing sufficient entry deflection is one of the most important design parameters for roundabouts with high speed approaches.

At high speed approaches or rural locations, the Designer may consider additional speed reducing design elements including:

- Providing visibility of the roundabout from a greater distance.
- Adding reverse curvature at the high speed approach leg. The reverse curves should have a broad radius at the first curve, moderate at the second, and a sharp radius at the last curve before the yield line. See Section 6.5 in [*Roundabouts: An Informational Guide*](#), FHWA for a graphical representation.
- Alignment and cross-sectional cues to alert drivers of the pending change in geometry, such as longer splitter islands for additional deceleration length (see AASHTO recommendations for required braking distance), adding curb or curb and gutter to both sides of the approach, and a transition section where the shoulders narrow for the curbed section.
- Additional signs and pavement markings to supplement geometric features, landscaping features to produce a “tunneling” effect, and roadway lighting.

Standard AASHTO guidelines for island design should be followed for the splitter island designs. This includes using larger nose radii at approach corners to maximize island visibility and offsetting curb lines at the approach ends to create a funneling effect. The funneling treatment also aids in reducing speeds as vehicles approach the roundabout.

For rural locations where a roadway shoulder is being used for a bike route or for urban areas designated as a bike lane, the shoulder should not continue through the roundabout. The roadway shoulder should end approximately 100 feet prior to the yield line and a bicycle ramp should be provided to allow cyclists the option of exiting the roadway to a multi-use path around the roundabout or remaining on the roadway. Riders choosing to continue through the roundabout will be required to merge with the vehicular traffic in both position and speed. The additional lane width of the circulatory roadway should be adequate to accommodate cyclists choosing to pass

TDOT ROADWAY DESIGN GUIDELINES
CHAPTER 2 GEOMETRIC DESIGN CRITERIA

English

Revised: 04/24/23

through the circle. The Designer should not specifically mark a shoulder or bike lane within the circulatory roadway.

2-1001.06 GRADING AND DRAINAGE CONSIDERATIONS FOR ROUNDABOUTS

The optimum grading scheme for a roundabout is to slope the circulatory roadway away from the central island (i.e. the center of the central island is the highest point in the intersection). This will aid in achieving the desired visibility of the central island to the approaching motorist. The Designer should accept the adverse superelevation for left turning and through vehicles in the travel lanes of the circulatory roadway.

While each location will be unique, grading a roundabout to slope away from the central island should follow these general guidelines:

- The ground slope of the central island should not exceed 6H:1V (per AASHTO *Roadside Design Guide*).
- The central island earthen area should always be raised, not depressed.
- The slope of the truck apron should not exceed 4 percent and should normally be between 2 and 3 percent, away from the central island. When the entire intersection is placed on a constant longitudinal grade, special attention should be given to ensure that the slope of the truck apron on the down-grade side of the center circle does not exceed 4 percent. Apron cross-slopes above 4 percent may lead to roll-over or load shifting within trucks.
- Roadway cross slope of the circulatory roadway should be a maximum of 2 percent sloping away from the center circle. Superelevation sloping toward the central island will normally result in increased vehicle speeds and will additionally result in the need to place stormwater inlets along the truck apron.
- The maximum grade in any direction of travel along the circulatory roadway should be 4 percent.

The Designer should note that by sloping the entire intersection away from the central island, visibility is improved since the center of the circle becomes the highest point in the intersection. Sloping the roadway inward is not preferred, unless the design is for a multi-lane roundabout in which one-third of the lane width can slope inwards and two thirds can slope outwards from the central island.

Stormwater runoff should be controlled to minimize sheet flow across the roundabout. The Designer should consider the vehicle wheel path traveling through the roundabout when considering placement of catch basins and inlets. The most desirable location of stormwater inlets is between the entrance and exits of the roundabout. Additional inlets in the roundabout may be required and installed above the splitter islands. Concentrated storm drainage that is directed towards a roundabout should be intercepted (where practical) prior to entering the circulatory roadway. The Designer should not place inlets or low points within crosswalks.

Drainage for the circulatory roadway should typically be toward the exterior of the intersection; away from the central island. Inlets should be placed in the outer curb line of the roundabout, away from, and up-slope, of crosswalks. When the roundabout is placed on a roadway with a constant grade that passes completely through the intersection, the Designer may

TDOT ROADWAY DESIGN GUIDELINES
CHAPTER 2 GEOMETRIC DESIGN CRITERIA

English

Revised: 04/24/23

be required to place an inlet adjacent to the central island. In rare cases where the central island is large enough and/or contains complex landscaping plans, the Designer may consider placing an area drain within the central island to minimize runoff to the roadway.

2-1002.00 GEOMETRIC DESIGN ELEMENTS FOR ROUNDABOUTS

A roundabout intersection incorporates a different group of geometric elements than a traditional signal or stop controlled intersection. Roundabout design ranges should not be considered absolute. Some locations may require the Designer to deviate slightly from the given design ranges on an as-needed basis. The following list of geometric features is generally considered the most basic of design elements for a simple roundabout intersection.

1. **Inscribed Circle Diameter (ICD)** is the basic diameter of the roundabout circle. The ICD is measured from curb face to curb face across the largest part of the circle. The ICD size can vary at different parts of the circle due to spirals on the inside lanes (see *Figure 2-35, Spirals for Multi-lane Roundabouts*). Larger ICDs may help to reduce circulating speeds but may also result in the need for additional right-of-way. Determining the optimal ICD size is typically an iterative process. The Designer may consider making minor changes in the size of the ICD, but should also be cautioned from deviating too much from the original requirements of the roundabout traffic model. See the RD-series Standard Drawings for ICD size.

The use of a smaller ICD may not adequately allow for the WB-62 to make a left or U-turn. Ultimately, the design vehicle selected will have a direct influence on the ICD, especially for single lane roundabouts where the ICD is most influenced by the vehicle selected. While a truck apron is required at all roundabouts, the width of the truck apron may be larger when the ICD is small.

2. **Circulatory Roadway Width** is the travelled way width of the roadway for vehicles circulating around the central island. This width is typically measured from the sloping curb face at the central island to the edge of the gutter of the ICD. The width of the circulatory roadway is directly dependent on the entry width into the roundabout, and is typically designed to be 1.0 to 1.2 times as wide as the width of the largest entry. The circulatory roadway width does not include the mountable truck apron.
3. **Spirals** are used to lead vehicles into their proper lane within the circulating roadway and are effective in keeping vehicles in the proper lane as they traverse the roundabout. A spiral is either a hard raised surface or painted line that develops at the central island and continues "spiraling out" until it ties into a circulating lane. Spirals should be considered for use when multiple left-turning lanes are present so that turning movements and through movements do not overlap. *Figure 2-35, Spirals for Multi-lane Roundabouts* depicts two options for providing spirals when used in a design at a multi-lane roundabout.

TDOT ROADWAY DESIGN GUIDELINES
CHAPTER 2 GEOMETRIC DESIGN CRITERIA

English

Revised: 04/24/23

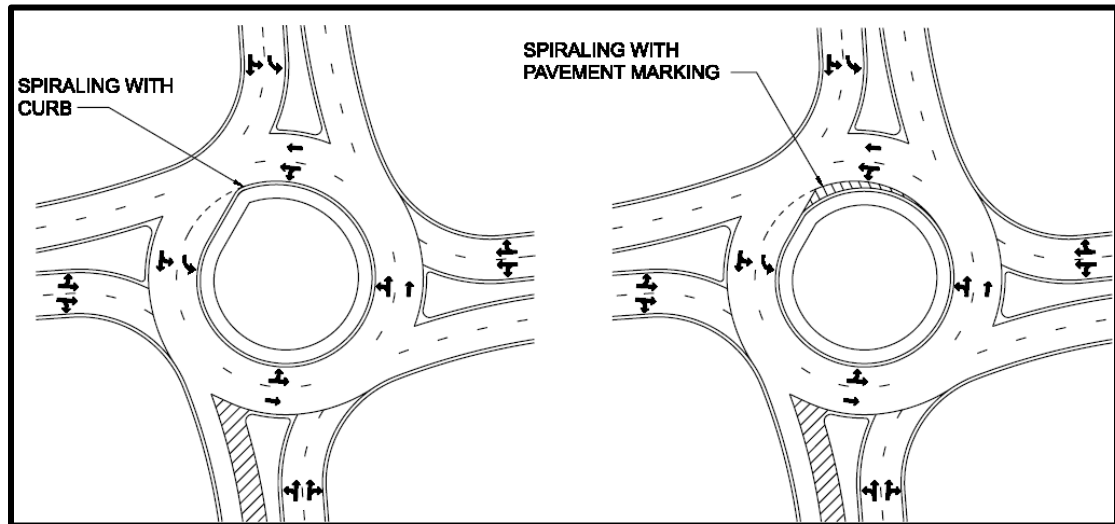

Spiral with Extended Central Island
(Preferred)

Spiral with Pavement Marking
(Acceptable)

Figure 2-35
Spirals for Multi-lane Roundabouts

- Entry Deflection** is the curvature (deflection) of the roadway as the roadway enters the roundabout. Deflection is used as a passive speed control measure for entering vehicles and should be applied prior to the yield line. Proper and adequate entry deflection promotes reduced entry speed and speed consistency. Deflection also positions the entering vehicle so that the driver can see the circulating vehicles already in the roundabout. Entry deflection has a direct correlation with fastest path speeds, phi angle, truck turning movements, and path overlap, and will ultimately affect all aspects of a roundabout. Deflection is also critical for preventing wrong way movements at the entries.

If the computed speed at the entry is high, the Designer should consider increasing the entry deflection. To gain additional area for entry deflection, the Designer can offset the roadway alignment of the approach leg to the left of the circle center. When used, a left-of-center offset is particularly beneficial to achieving desired deflection at roundabouts with small ICD's.

- Entry Width** is the width of the entering travelled way as it approaches the roundabout after the flare length has ended (flare length is the distance from approach width to entry width). Entry width is the largest determinant of a roundabout's capacity and has a direct correlation to the fastest path measurement and truck turning movements. The most accurate location for measuring entry width is typically at the end of the splitter island, beginning at the intersection of the yield line and the left edge of the travel way, measured to the right edge of travel way. This measurement should be taken perpendicular to the right (exterior) gutter. Design ranges for entry width are provided on the Standard Drawings.

TDOT ROADWAY DESIGN GUIDELINES
CHAPTER 2 GEOMETRIC DESIGN CRITERIA

English

Revised: 04/24/23

6. **Entry Radius** is the radius of the curve that leads vehicles into the roundabout. The entry radius is measured at the face of the outer curb line. The Designer should use a radius that is small enough to reduce vehicle speeds, but not so small that vehicle turning movements are compromised. Acceptable ranges for entry radius can be found on the Standard Drawings.
7. **Exit Width** is the width at the exit roadway from a roundabout measured from curb face to curb face. The exit width should correlate with the upstream entries and circulating roadway width to ensure that it is wide enough. The Designer should ensure that the exit width provided is not too narrow for vehicles as they attempt to leave the roundabout, resulting in possible delays. In general, the exit width should be no less than the entry width and it should transition to the full width cross-section of the receiving roadway.
8. **Exit Radius** is the radius of the curve that leads a vehicle out of the roundabout. The radius is measured along the face of the outer curb line. Exit radii are generally larger than entry radii to allow for smoother exits and minimize the potential for delays; however, to ensure low speeds at the downstream crosswalk, the exit path radius should not be significantly greater than the circulatory path radius either. Ideally, the exit curve should be tangential to the circulatory roadway. Design ranges for exit radius can be found on the Standard Drawings.
9. **Approach Width** is the width of the approach leg prior to the flare length. The approach width, or half width, is measured from edge of travel way to edge of travel way.
10. **Right-Turn Bypass Lane (Slip Lane)** is an exclusive lane used to accommodate a high right-turn volume; whereby, allowing right-turning traffic to bypass the roundabout. See *Figure 2-36, Typical Right-Turn Bypass Lane*, for a schematic of a typical right turn bypass lane. In areas that have a high volume of pedestrian traffic, additional attention should be given to the design of the right turn bypass lane to allow for pedestrians to have the right-of-way. The Designer should consider other options for accommodating anticipated right-turn volumes prior to using a bypass lane in an urban environment due to the potential for high pedestrian volumes. However, in some cases, the need for a multi-lane roundabout may be eliminated by providing a right-turn bypass lane.

For rural roundabouts, right-turn bypass lanes may be considered when their need is warranted. When used, the Designer should accommodate for greater vehicle speeds in the bypass lane and an increased risk to pedestrians crossing the quadrant of the intersection where the bypass lane is to be located. The project Designer should examine the present and projected pedestrian and bicycle demand at the rural location under consideration, and properly design pedestrian crossings, signalization, and signing at the bypass lane.

TDOT ROADWAY DESIGN GUIDELINES
CHAPTER 2 GEOMETRIC DESIGN CRITERIA

English

Revised: 04/24/23

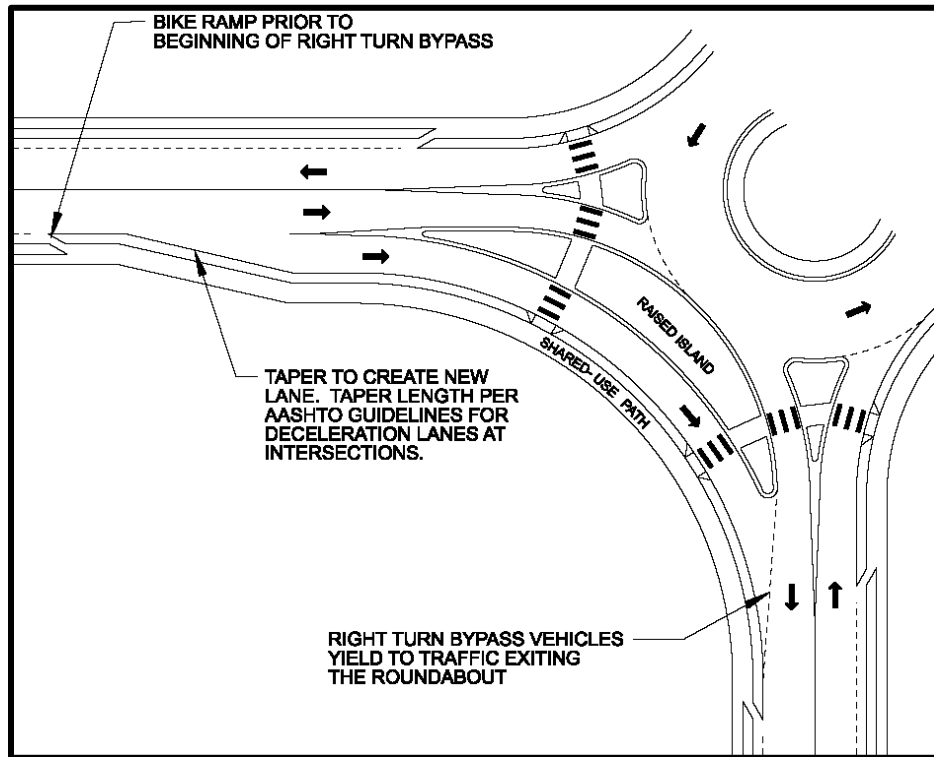

Figure 2-36
Typical Right-Turn Bypass Lane

Where a bypass lane is used, the following design criteria should be considered:

- Run a fastest path check through the bypass lane so that the bypass lane does not produce excessive speeds. Vehicle speeds in the bypass lane should be similar to those in the roundabout.
- Once a vehicle is committed to using the bypass lane, the design should not allow for access back into the circulating roadway.
- Minimizing the radius of the bypass lane may provide greater safety for crossing pedestrians; however, the design vehicle should be checked on all aspects of the bypass lane geometry.
- Traffic exiting the roundabout should be given the right-of-way over traffic exiting any bypass lanes. Providing a yield-controlled entrance onto the adjacent exit roadway from the bypass lane is required.
- In rural locations where right-of-way is available, an acceleration lane with appropriate taper rates based on AASHTO guidelines is the preferred merging method at the end of the bypass lane.
- Pedestrian crossing points should be designed per PROWAG guidelines in addition to the other requirements found in these roundabout guidelines.
- Proper lighting should be provided, where applicable.

Bypass lanes can potentially add a significant amount of required right-of-way area to the intersection design. The final decision to use a bypass lane should take into

TDOT ROADWAY DESIGN GUIDELINES
CHAPTER 2 GEOMETRIC DESIGN CRITERIA

English

Revised: 04/24/23

account pedestrian and right-of-way constraints. Proper analysis should ensure all right-turn bypass lanes have been justified prior to proceeding with a detailed design.

11. **Truck Apron** is a mountable circular concrete pad along the outer edge of the central island used to accommodate turning movements of larger vehicles. The truck apron is designed to allow the rear tires of large vehicles to traverse the apron as they are making through and left turn movements. The width of the truck apron should be in the range of 6 to 10 feet. Final truck apron design (width) should be based on truck turning analysis (design vehicle tracking) plus a recommended buffer of 2-feet in width for driver irregularity. Truck aprons should not be less than 6 feet wide.

The truck apron shall not be flush with the traffic lanes nor merely painted on the roadway surface. Truck aprons are not intended for passenger vehicles or small trucks; therefore, a sloping curb that provides enough vertical grade difference should be used so as to appear unappealing to the driver of a smaller vehicle.

It is preferable that the design of the truck apron provide a color or surface texture contrast from the circulatory roadway. This should normally be accomplished with an asphalt roadway and a concrete truck apron. Where the roadway surface is to be concrete, the Designer may consider the use of stamped or colored concrete or brick pavers to achieve this contrast. The use of asphalt on the truck apron should be avoided.

2-1003.00 ROUNDABOUT DESIGN CHECKS AND MEASUREMENTS

Roundabouts are generally considered a passive form of intersection control. Roundabouts create a situation in which drivers are expected to slow down as they enter the intersection through the use of visual cues and roadway geometry. Since a roundabout does not require a vehicle to completely stop, the design should ensure that vehicle speeds are reduced as the vehicle enters the roundabout. Vehicles entering at a slow, consistent, and controlled pace are essential to roundabout design, safety, and operation.

Design checks are measurements that are taken on various geometric elements of a roundabout to verify that the design will have sufficient entry angles, proper deflection and speed reduction, adequate area for turning movements, and adequate sight distance. Design checks are also necessary to show that the desired capacity and speed will be maintained for the types of vehicles that are expected to use the intersection. The design check process is essential to a roundabout design. Verifying the design through the use of design checks can be a tedious process, but is necessary for proper roundabout design.

The following design checks should be performed for proper roundabout design:

1. **Fastest Path** – The measure of a single vehicle’s shortest (smoothest) path through a roundabout given the absence of any other traffic and given that the driver ignores all lane markings, traverses the entry, and travels around the central island and through the exit. In order for the Designer to determine the maximum expected vehicle speeds at, and through the roundabout, fastest path measurements should be calculated. The fastest path should be measured at all

TDOT ROADWAY DESIGN GUIDELINES
CHAPTER 2 GEOMETRIC DESIGN CRITERIA

English

Revised: 04/24/23

approaches to a roundabout and should include path analysis for all left-turn, right-turn, and through movements at the intersection (i.e. a total of 12 measurements for a 4-leg intersection). Under certain circumstances, the critical path may be the right-turn movement; however, in most cases it will likely be the through movement. The longest of the fastest paths is typically the left-turn movement at the intersection.

Fastest path measurements are typically taken by constructing a b-spline (polyline) curve in a CADD program. The b-spline curve (See *Figure 2-37, Fastest Path for Through Movement at Single Lane Roundabout*) should represent the centerline of the vehicle that is attempting to traverse the roundabout at the highest rate of speed possible while ignoring other vehicles, pedestrians, pavement markings, and signing. Three b-spline curves should be constructed for each approach into a roundabout.

When laying out a b-spline curve, the Designer should use an assumed width for a vehicle of 6 feet and to maintain a minimum of 2-feet of clearance from the roadway centerline or any curb face. When constructing b-spline curves for the centerline of the vehicle path, maintain the following minimum offset distances:

- 5 ft. from face of a concrete curb (2' clearance + 3 ft to center of vehicle),
- 5 ft. from a roadway centerline, and
- 3 ft. from a painted edge line (if no curb is present).

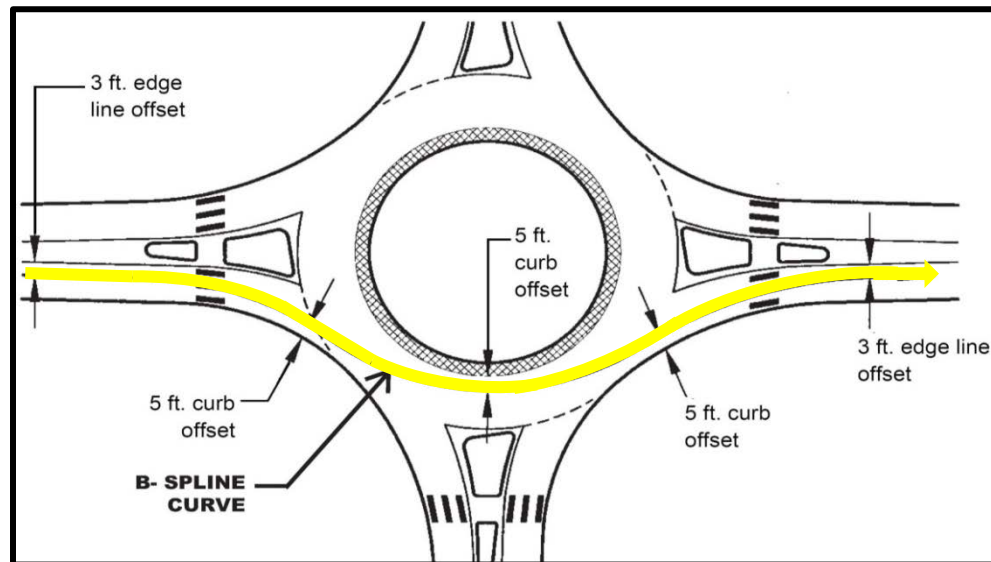

Figure 2-37
Fastest Path for Through Movement at Single Lane Roundabout

Adapted From: FHWA, *Roundabouts: An Informational Guide*

The through movement b-spline curve (as shown above in *Figure 2-37, Fastest Path for Through Movement at Single Lane Roundabout*) will be constructed to

TDOT ROADWAY DESIGN GUIDELINES
CHAPTER 2 GEOMETRIC DESIGN CRITERIA

English

Revised: 04/24/23

represent a vehicle entering a roundabout, passing to the right of the central island, and exiting the roundabout on the opposite side of the circle. The left-turn movement b-spline curve will be constructed to represent a vehicle entering a roundabout and making a left turn around the central island. The right-turn movement b-spline curve will be constructed to represent a vehicle entering a roundabout and then making an immediate right turn out of the roundabout. These movements are depicted in *Figure 2-38, Critical Path Radii at a Roundabout*.

Once the Designer has constructed b-spline curves for the through, left-turn, and right-turn movements for each approach to the roundabout, corresponding speeds can be computed from each critical (minimum) path radius measured along the b-spline curve. The five critical path radii in a roundabout are:

- R1 - The minimum radius on the through movement b-spline curve, typically measured prior to the yield line, but not more than 165' prior to yield line.
- R2 - The minimum radius on the through movement b-spline curve measured in the circulatory lanes around the central island.
- R3 - The minimum radius on the through movement b-spline curve measured at the exit to the roundabout.
- R4 - The minimum radius on the left-turn b-spline curve measured in the circulatory roadway around the central island.
- R5 - The minimum radius on the right-turn b-spline curve measured at the tightest point.

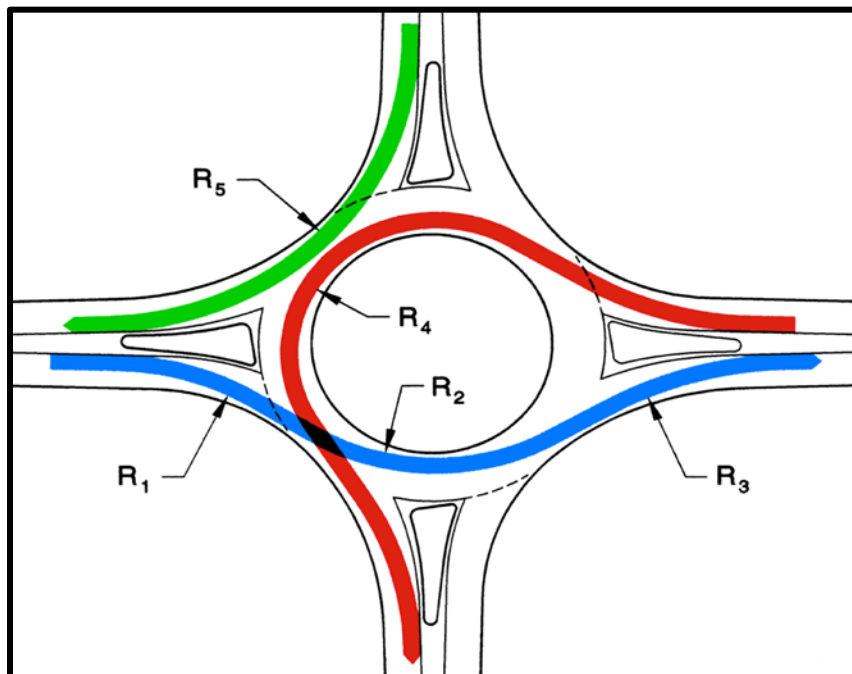

Figure 2-38
Critical Path Radii at a Roundabout

Reference: FHWA, Roundabouts: An Informational Guide

TDOT ROADWAY DESIGN GUIDELINES
CHAPTER 2 GEOMETRIC DESIGN CRITERIA

English

Revised: 04/24/23

It should be noted that the critical path radius does NOT equal curb radius. Each critical path radius should be measured in a CADD program; generally the Designer can draw a new curve on top of the b-spline curve in order to measure the critical radii. Speeds should be recorded for all critical radii. Once the critical path radii are measured, the Designer can determine the corresponding speed associated with each critical path radius using methodology in AASHTO's *A Policy on Geometric Design of Highways and Streets*. *Figure 2-39, Speed-Radius Relationship*, correlates the measured radius to a computed speed using the AASHTO methodology.

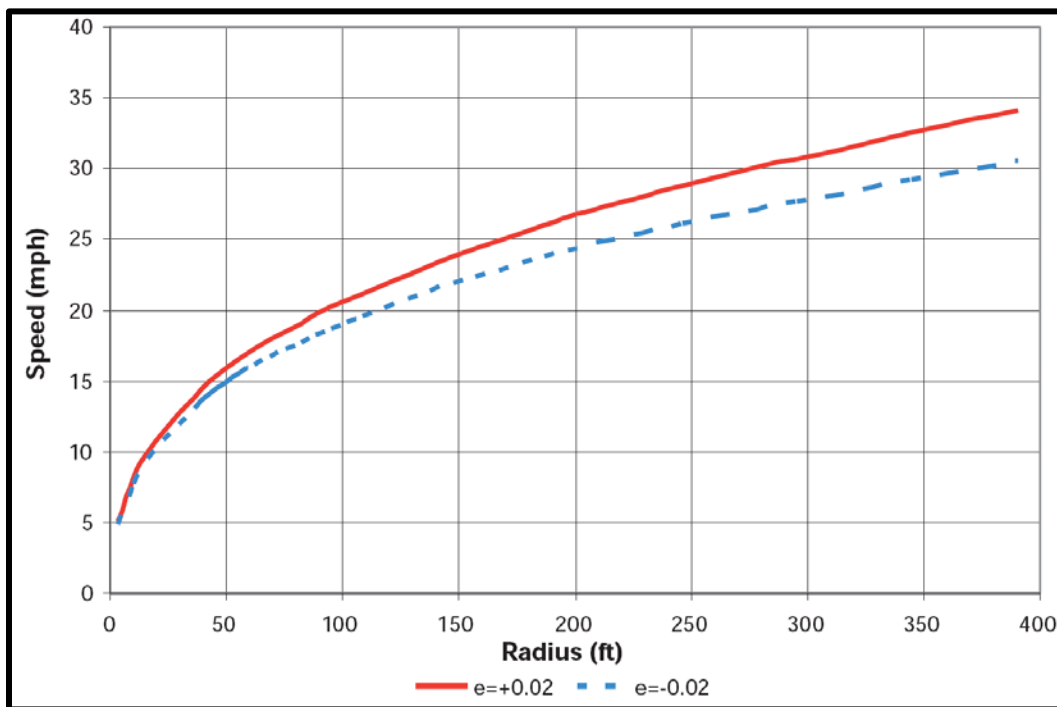

Figure 2-39
Speed-Radius Relationship

Reference: FHWA, Roundabouts: An Informational Guide

Figure 2-39, Speed-Radius Relationship, gives the Designer an estimate of the maximum speeds through the roundabout at various locations: entrance, circulatory roadway, and exit. Use the +0.02 curve for measurements at the entry and exit (R1, R3, and R5) and use the -0.02 curve for those around the central island (R2 and R4).

Speed consistency is critical and should be checked between all fastest path measurements. The Designer should attempt to minimize variations in vehicular speeds. If one path has a speed differential significantly higher than the other

TDOT ROADWAY DESIGN GUIDELINES
CHAPTER 2 GEOMETRIC DESIGN CRITERIA

English

Revised: 04/24/23

paths, that movement will tend to control the roundabout and the lower speed movements will be affected with longer queues. A speed differential of no more than 6 mph is preferred between all paths. Since this may not always be possible, a speed differential of 12 mph shall be considered the maximum allowable. It is preferable for R3 to be greater than R2, and R2 to be greater than R1 (i.e. the entrance has the lowest speed).

When the initial design will not produce adequate speed consistency, the Designer has several options for consideration to remedy the situation. The following is a list of options that the Designer may consider to correct a speed control problem:

- Adjust the size of the inscribed circle diameter a few feet, either making it smaller or larger as needed.
- Adjust the entry radius by a few feet by either making it smaller or larger.
- Re-design the entry or exit so that the entry angle changes, thus creating more or less deflection as needed.
- Move the entire circle in one direction to increase or decrease the entry deflection.
- Re-evaluate the modeling to determine if a different lane configuration will be acceptable.

Designers should be aware that any change to a geometric element will affect the previously computed roundabout design checks and all checks will need to be re-evaluated after geometric changes are made.

2. **Phi Angle** – The angle measured between the entering and exiting roadways. In the case of a three legged roundabout, it is the angle measured between the entering and circulatory roadway. When the angle is measured between the entering and exiting roadways, the actual phi angle is half the angle measured. In the case of an angle being measured between entering and circulatory roadways, the phi angle is the angle measured.

Phi angle is typically measured as a design check to verify that the entering roadway, in relation to the nearest exiting roadway, allows a driver to see oncoming traffic within the circle without the driver having to turn their head in an uncomfortable position. When a driver approaches the yield line, the roundabout geometry should allow for the driver to see oncoming vehicles within the circle without having to look over their left shoulder excessively; whereby producing driver discomfort. Acceptable values for the phi angle typically range from 16 to 40 degrees.

3. **Path Overlap** – A critical design issue for multi-lane roundabouts occurs when the natural paths of entering and exiting vehicles in adjacent lanes overlap or cross each other. This occurs when a vehicle enters a roundabout and is directed into an adjacent lane once inside the circulatory roadway as shown in *Figure 2-40, Example of Vehicle Path Overlap*. The existence of path overlap should be checked at both the entrance and exits.

TDOT ROADWAY DESIGN GUIDELINES
CHAPTER 2 GEOMETRIC DESIGN CRITERIA

English

Revised: 04/24/23

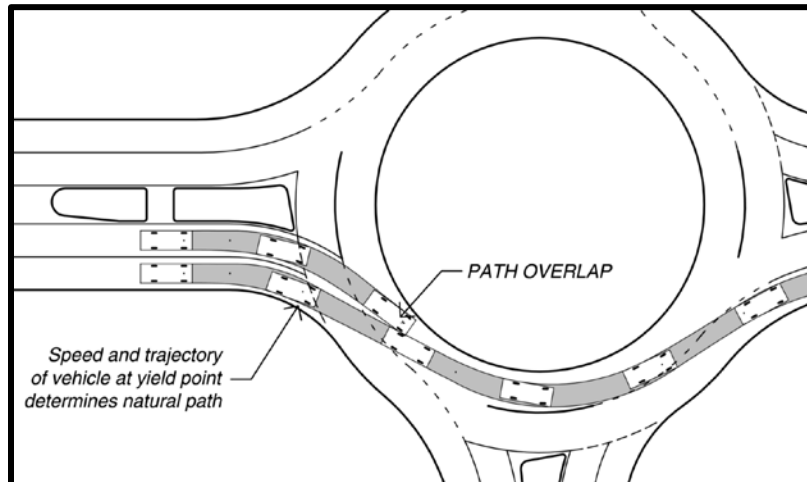

Figure 2-40
Example of Vehicle Path Overlap

Reference: KDOT, Kansas Roundabout Guide

Larger exit radii and/or tangential exits will aid in reducing the potential for exit path overlap. The Designer can minimize the potential for entry path overlap by providing adequate entry deflection and ensuring multi-lane vehicle entry paths are properly aligned with the circulatory lanes ahead at the yield line. To accomplish this, the Designer should locate the entry curve so that the projection of the inside entry lane at the yield line connects tangentially, or nearly tangentially, to the curb line ahead at the central island, as seen in *Figure 2-41 Good Path Alignment into Multi-Lane Roundabout*.

TDOT ROADWAY DESIGN GUIDELINES
CHAPTER 2 GEOMETRIC DESIGN CRITERIA

English

Revised: 04/24/23

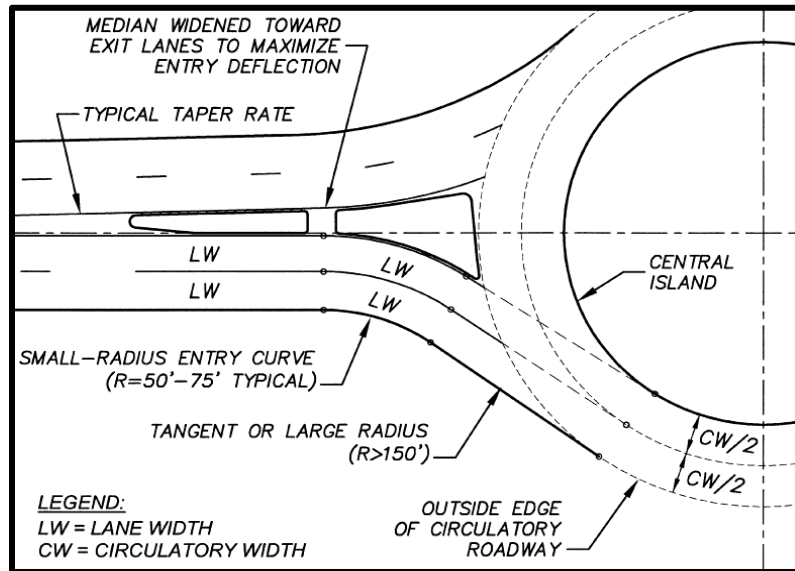

Figure 2-41
Good Path Alignment into Multi-Lane Roundabout

Reference: FHWA, *Roundabouts Technical Summary (FHWA-SA-10-006)*

Multi-lane roundabouts should be designed to minimize the potential for entry and exit path overlap which results in reduced operational performance due to unbalanced lane utilization on the approach. The Designer should be particularly aware of path overlap, since it can lead to a higher rate of side-swipe collisions and may be adverse to the desired capacity of the roundabout. FHWA's [Roundabouts: An Informational Guide, 2000](#); provides additional suggestions for eliminating path overlap at a multi-lane roundabout.

4. **Truck Turning Movements** – Truck movements should be reviewed for all roundabout designs to verify that the design vehicle can properly navigate all required turns. The right-turn movement tends to be the most challenging movement for a truck. The roundabout should be designed so that the truck tires do not track over the exterior concrete curbing or combined curb and gutter for the right-turn movement, nor over the splitter island curbing at the entry and exits. Trucks that are continuing through the roundabout or making a left turn can use the truck apron within the central island.

TDOT roundabouts should be designed to accommodate a WB-50 vehicle within the traffic lanes, with the WB-62 design vehicle (or larger) expected to have to track over the truck apron. The truck apron at the central island will allow larger vehicles to track around the central island.

5. **Stopping Sight Distance/Intersection Sight Distance** – Key elements to safety and operating speed of a roundabout. There are three critical types of stopping sight distance that should be measured at roundabout intersections. Approach stopping sight distance, stopping sight distance on the circulatory roadway, and stopping sight distance to a crosswalk. These distances are normally measured to

TDOT ROADWAY DESIGN GUIDELINES
CHAPTER 2 GEOMETRIC DESIGN CRITERIA

English

Revised: 04/24/23

verify that there are no obstructions within the sight lines (triangles). Refer to FHWA's [Roundabouts: An Informational Guide](#) or the Standard Drawings for diagrams on the proper method for measuring stopping sight distance.

When measuring intersection sight distance, there are two conflicting approaches for a vehicle entering the roundabout. Intersection sight distance with the conflicting upstream entry and intersection sight distance within the circulatory roadway should be determined. Each should be checked independently and each should be measured along the expected vehicular path on the roadway, not as a straight line. Studies have shown that providing the minimum intersection sight distance may actually aid in speed reduction at some locations; however for TDOT projects, speed should be controlled with geometric and other design elements, not by means of limiting sight distance. See [Section 2-1001.03, Longitudinal Grade Considerations for Roundabouts](#), for additional speed reduction design elements.

Stopping sight distance to crosswalks should be verified for both the entry and exit of the roundabout; especially at the exit crosswalk. NCHRP (Report 572, 2007) studies have shown that a higher percentage of drivers do not yield to pedestrians at the exit when compared to the entry. The proper design of the exit is essential to ensure adequate sight lines are provided between the driver and the pedestrian and that speeds are held to the desired amount. The Designer should consider additional design features that will provide improved safety to pedestrians at crosswalks.

The roundabout design process should be considered an iterative process throughout the design. There may be several acceptable designs for a given location that will meet the desired performance objectives; however, this is rarely achieved on the first design iteration. Because of this, it is advisable that the Designer prepare the preliminary layout drawings to a "sketch" level of detail. Design components are interrelated, and changing one affects others, so it is important that the Designer evaluate the performance of the entire intersection design as changes are made to ensure that the individual components are compatible. If a change is made to one component of a roundabout design, such as the ICD size, angle of approaches, or lane width, the Designer should verify that other components of the roundabout will still meet the design criteria.

The flow chart in *Figure 2-42, Typical Roundabout Design Procedure*, provides the general procedure and steps for designing a typical roundabout.

TDOT ROADWAY DESIGN GUIDELINES
CHAPTER 2 GEOMETRIC DESIGN CRITERIA

English

Revised: 04/24/23

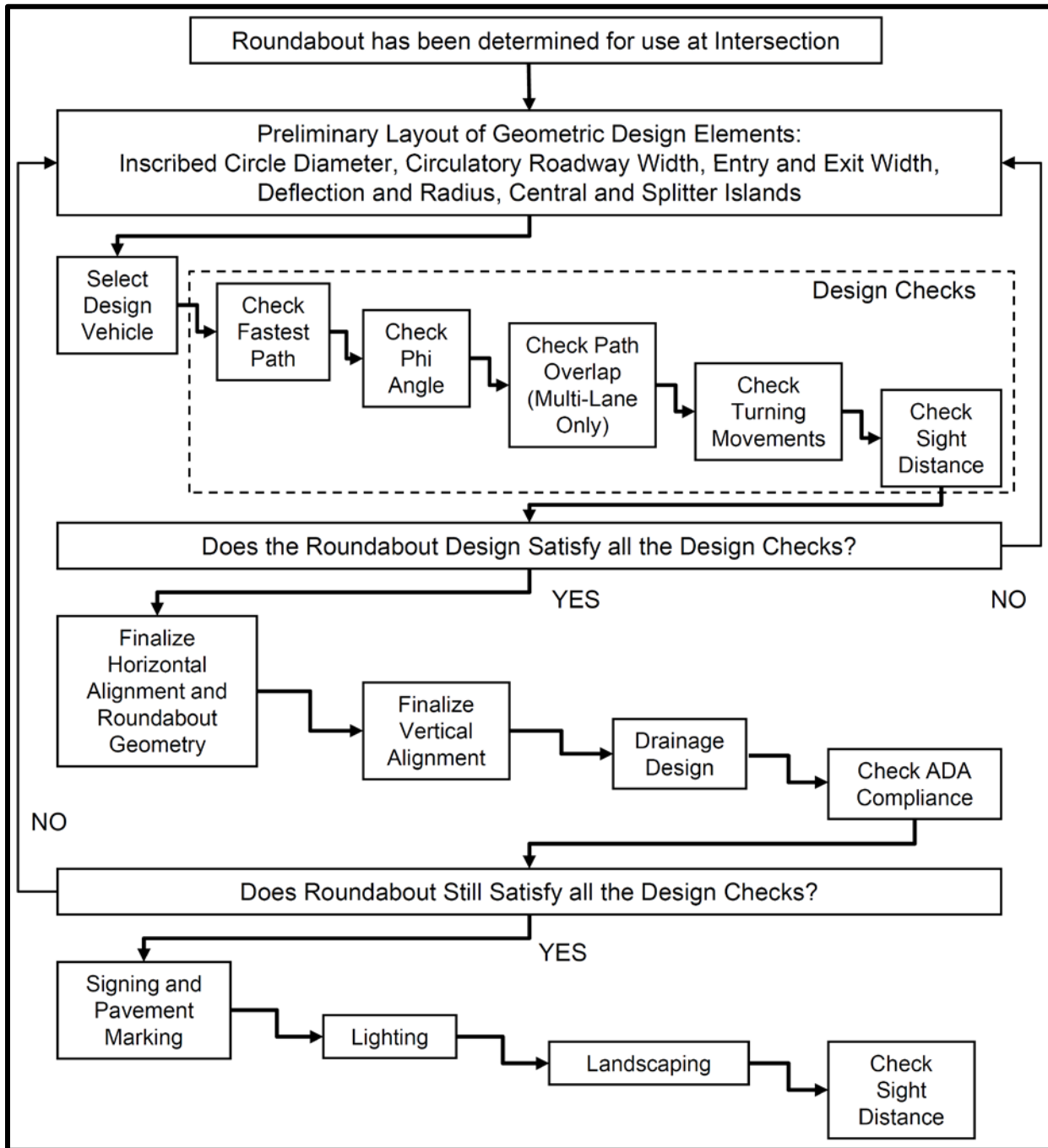

Figure 2-42
Typical Roundabout Design Procedure

TDOT ROADWAY DESIGN GUIDELINES
CHAPTER 2 GEOMETRIC DESIGN CRITERIA

English

Revised: 04/24/23

2-1004.00 ROADWAY DESIGN CONSIDERATIONS FOR ROUNDABOUTS

2-1004.01 DETERMINING ROUNDABOUT LOCATION

For projects utilizing a roundabout for intersection control, optimum location, project goals, and system considerations should be reviewed before formal design begins. These additional design considerations should take into account existing and proposed grades, availability and cost of right-of-way, proximity to other intersections (especially signalized intersections), railroad crossings, intersecting roadway skew angles, and private driveway locations.

2-1004.02 ROUNDABOUT PROXIMITY TO OTHER INTERSECTIONS

Roundabout proximity to other types of intersection control should be considered when determining a location for a roundabout. The typical spacing between intersections where one or more of the intersections is a roundabout will generally be shorter than a series of signalized or stop controlled intersections. There is no absolute minimum distance between a roundabout and another intersection. In order to determine a satisfactory distance, a queue length evaluation should be completed prior to commencing with design. This queue length evaluation should include all queue lengths associated with the roundabout and any adjacent signalized or stop controlled intersections.

2-1004.03 ACCESS MANAGEMENT AND PRIVATE DRIVEWAYS AT ROUNDABOUTS

Parking will not be allowed within the circulatory roadway of roundabouts designed by the Department. The Designer should attempt to minimize or avoid locating on-street parking areas within the splitter island area or within the transition to the splitter island. For new designs, parking should be terminated a minimum of 75 feet from the yield point, which is at the entrance to the circulatory roadway.

Where driveways are present, the Designer should consider methods for locating private driveways outside of the roundabout, so that a vehicle cannot take direct access to the circulatory roadway from the private property. Additionally, the Designer should avoid providing private driveways anywhere within the vicinity of the splitter island. Where this is unavoidable, the driveway connection should be designed with a small raised island restricting traffic to a right-in/right-out movement, and the Designer should check for proper sight distance to the left of the driveway for vehicles entering or exiting the roundabout. For most TDOT projects, driveway access between the crosswalk and yield line at the entrance (or exit) to the roundabout will not be permitted except under extraordinary circumstances.

Bus stops should be located as far away as possible from the entries and exits and should not be placed within the circulatory roadway or within the area of the splitter islands. Pedestrian crossing areas at the splitter islands should not be used for bus stop locations.

TDOT ROADWAY DESIGN GUIDELINES
CHAPTER 2 GEOMETRIC DESIGN CRITERIA

English

Revised: 04/24/23

2-1004.04 RAILROAD CROSSINGS AT ROUNDABOUTS

Roundabouts should not be designed at a location where the existing railroad line will pass through the center circle (or any portion) of the roundabout. The exception to this will be where an existing intersection is being reconstructed and an existing rail line currently passes through the intersection. Even in this case, the Designer should explore all options for re-locating the roundabout to a location that the rail line crosses only one leg in proximity to the roundabout. In all cases involving a project in close proximity to a railroad track, the Designer should acquire a queue length evaluation to ensure that vehicles will not queue onto the active rail line. Another option to minimize the possibility of a vehicle being on the railroad track is to pre-empt the roundabout with gates or flashing beacons at all the entrances and the exit feeding to the railroad track.

2-1004.05 SERIES OF ROUNDABOUTS

Roundabouts should be evaluated for installation along a corridor, because they have advantages and disadvantages over traditional signalized corridors and may provide for design flexibility in urban and developing areas. Traffic and planning studies should be evaluated before considering a corridor containing a series of roundabouts. Each roundabout in a corridor or ramp interchange should be designed as a completely new intersection, just as a Designer would treat a series of signalized intersections.

Roundabouts typically tend to have higher capacities and lower delays than traditional signalized intersections. This leads to shorter travel times through roundabout corridors than through signalized corridors.

2-1004.06 ROUNDABOUTS USED AT INTERCHANGES

Roundabouts may be considered as an acceptable design option for intersection control at interchange ramp locations. Unlike a typical stop or signal controlled interchange, roundabouts generally require less space between ramps. This may save on right-of-way costs when considering a new interchange, especially when right-of-way is constrained or when the interchange is located near a narrow structure such as an underpass or overpass. Additionally, when designing a roundabout in close proximity to an interstate or other controlled access route approved for large trucks, the WB-62 design vehicle should be used for analysis.

Sight distance should be a significant design parameter when designing tightly spaced roundabouts at interchanges. The Designer should verify that bridge abutments, piers, and/or bridge railings do not interfere with sight distance requirements. A full traffic analysis should be performed before a roundabout is considered at an interchange since roundabouts will be closely spaced. Additionally, an analysis should be performed to verify that required and appropriate signing can be adequately provided and visible to motorists at both new and retrofitted interchange locations.

TDOT ROADWAY DESIGN GUIDELINES
CHAPTER 2 GEOMETRIC DESIGN CRITERIA

English

Revised: 04/24/23

2-1005.00 PEDESTRIAN, BICYCLE, AND PROWAG CONSIDERATIONS FOR ROUNDABOUTS

The number of pedestrian/vehicle conflict points is reduced when a roundabout is used for intersection control. Since a roundabout may not have pedestrian signal phases or pedestrian push-buttons, and does not require vehicles to make a complete stop, other measures should be designed to ensure drivers and pedestrians are clearly able to see each other. Proper design should produce conditions needed to allow vehicles to yield to the pedestrians and at a reduced speed.

Since a goal of any roundabout is to reduce speeds without actually stopping the vehicles, a properly designed roundabout will reduce the risk of pedestrian/vehicle collisions due to the slow speeds expected. There are design elements that may be beneficial to pedestrian safety when designing the crosswalks at a roundabout. The following general design criteria should be considered for crosswalks at roundabouts:

- Minimized crossing distance to reduce pedestrian exposure to traffic.
- Where possible, crosswalks should be designed to provide pedestrians a straight walking path across the traffic lanes (90 degrees to traffic flow preferred), including any right-turn bypass lanes. This may not apply to small single-lane approaches where a straight crossing route can be provided regardless of splitter island or roadway deflection.
- To minimize out-of-direction travel for pedestrians, crosswalks should be located as close as possible to the intersection while still maintaining required queue space for vehicles. A mid-block pedestrian crossing near a roundabout is not recommended.
- At single-lane roundabouts, crosswalks should typically be located one vehicle length (approximately 20 feet minimum) behind the yield line; this gives the driver at the yield line the ability to concentrate on entering the roundabout.
- For multi-lane roundabouts, crosswalks may be located one vehicle length behind the yield line. A Designer may need to “bend” crosswalk alignments at the splitter island, where necessary to provide 90 degree crossings at the entrance/exit lanes.
- Splitter islands should be a minimum width of 6 feet at the narrow end of the island – 9.5 feet preferred. The refuge area (gap) within the splitter island should be 10’ long. Therefore, the minimum dimensions for the refuge area should be 6’ x 10’. See the standard drawings.
- The finished grade of the pedestrian crossing (refuge) areas within the splitter islands should be at or slightly above the elevation of the adjacent pavement. The Designer should avoid elevating the refuge area except the minimal amount needed for proper drainage.

Additional details for crosswalks can be found on the standard drawings. The standard drawings for curb ramps provide details for ramps at the exterior curb cuts for crosswalks. The splitter island refuge area should be wide enough to accommodate multiple modes of pedestrian traffic, including side-by-side wheelchairs, bicycles with trailers, pedestrians, and pedestrians with baby strollers.

Accommodating designs for visually impaired and disabled pedestrians should be a priority at roundabouts since those pedestrians tend to rely on audio signals more than other pedestrians. Roundabouts generally do not require audio devices for pedestrian crossings, but in special cases they may be needed at a roundabout. In addition, detectable warning surfaces

TDOT ROADWAY DESIGN GUIDELINES
CHAPTER 2 GEOMETRIC DESIGN CRITERIA

English

Revised: 04/24/23

should be provided at all paths, including the splitter island refuge area, leading to any traffic lane. The Roadway Design Division's curb ramp standard drawings and roundabout standard drawings provide detectable warning surface details. All pedestrian facilities should be designed to comply with the latest version of PROWAG. See Chapter 3 – Multimodal Design for additional information.

The TDOT bicycle and pedestrian policy requires consideration be given to providing provisions for bicycles to be integrated into new construction and reconstruction of roadway projects through design features appropriate for the context and function of the transportation facility.

Bicyclists should be given a choice when approaching a roundabout of either going through the roundabout and mixing with the vehicles in the circulatory stream, or exiting the roadway prior to entering the roundabout and continuing around the roundabout on a shared-use path (sidewalk) with pedestrians. To optimize safety and the most efficient operation of the roundabout, bicyclists should be provided with shared-use paths around the perimeter of the roundabout. For the purposes of most TDOT design projects, the Designer should provide bike ramps for exiting the roadway to the shared-use path, and then ramps for re-entering the roadway, bicycle lane, or roadway shoulder on the opposite side of the roundabout.

The bicycle exit ramp (the ramp the bicyclist uses to exit the roadway prior to the roundabout) should be provided prior to the pedestrian crossing or at least 100' prior to the yield line, whichever of the two is greater. At the exits, a bicycle entrance ramp should be provided after a pedestrian crosswalk or 100' from the exit, whichever is greater.

Bicycle ramps should be a minimum 6' wide between the roadway and the shared-use path. This width will be large enough to accommodate a bicycle pulling a child cart, but small enough to prevent a vehicle from using it. The bicycle exit and entrance ramp should typically be placed at a 20 to 45 degree departure angle from the roadway. A perpendicular bicycle ramp is not recommended since it would require a bicyclist to stop their forward momentum as they exit (or enter) the roadway. See the standard drawings for details of bicycle entrance and exit ramps.

Where cyclists prefer to pass through the roundabout, the Designer should treat them as a vehicle in the circulating stream. Any designated bike lanes on the approach to the roundabout should be terminated a minimum of 100 feet upstream of the yield line. This will allow the bicycle to mix with the traffic, both in lane position and speed. Specific pavement markings for bicycles should not be present within the circulatory roadway.

If the roundabout is being designed at a location where there is a designated shared-use path, the design should include those geometric features detailed on standard drawing MM-TS-3. To minimize confusion between bicycle ramps and pedestrian ramps, detectable warning surfaces should be placed at the top of the bicycle ramps rather than at the bottom as is the practice with pedestrian ramps. At rural and urban locations where current pedestrian and bicycle traffic is not significant, but expected to increase, the Designer should include measures in the plans to accommodate future needs or demands. These may include:

- Rough grading the perimeter of the roundabout to accommodate future sidewalks, landscaping buffer strip, shared-use paths, etc.
- Installing curb ramps or lowered curb at logical "future" locations along perimeter curbing
- Providing cut-throughs (gaps) at the splitter islands for future crosswalks

TDOT ROADWAY DESIGN GUIDELINES
CHAPTER 2 GEOMETRIC DESIGN CRITERIA

English

Revised: 04/24/23

- Obtaining adequate right-of-way to accommodate future measures, including lighting

Additionally, the Designer should refer to the *Guide for the Development of Bicycle Facilities*, AASHTO 2012.

2-1006.00 SIGNING AND PAVEMENT MARKING FOR ROUNDABOUTS

The concept for signing and marking a roundabout is similar to standard intersection signing and marking. The signing and marking plan should stress proper regulatory, advanced warning, and directional guidance to provide positive guidance to the motorist. Each roundabout design will be unique, and the signing and marking plans can become complex. Signing and marking needs are different for urban and rural applications and for varying types of roundabouts.

All signing and marking plans should conform to the current edition of the [*Manual on Uniform Traffic Control Devices*](#) (MUTCD), FHWA. The [*Roundabouts: An Informational Guide*](#), FHWA, the Traffic Operations Division's [*Traffic Design Manual*](#) and the Standard Drawings may be used for additional reference or guidance for signing roundabouts and the approaches to a roundabout.

The following additional sign criteria should be considered for roundabouts over that which may be present at a normal intersection:

- Roundabout ahead signs
- Advanced diagrammatic guide signs and markings
- Yield signs on more than one approach to an intersection
- Long chevron plate typically used in the center circle
- Exit guide signs

For urban roundabouts, the design will need to balance providing adequate signing for a more familiar user of the intersection with the tendency to use too many signs. Street name signs are typically considered a necessity for urban locations. For rural applications, where higher approach speeds are expected and normal signage and geometric features will not produce the desired reduction in speed, the Designer should consider the following additional measures:

- Large advanced warning signs
- Word markings on the pavement
- Speed reduction warning signs

Additional requirements for pavement markings and signs for bicycles can be found on the T-M-series Standard Drawings.

2-1007.00 ROADWAY LIGHTING FOR ROUNDABOUTS

Illumination may be requested at urban and suburban roundabouts and the design should be coordinated with local officials. The lighting of rural roundabouts is recommended, but may not be necessary in all circumstances. The decision to illuminate a rural intersection should be on a case-by-case basis and will depend on factors such as availability of a power source, volume of

TDOT ROADWAY DESIGN GUIDELINES
CHAPTER 2 GEOMETRIC DESIGN CRITERIA

English

Revised: 04/24/23

anticipated night-time vehicular or pedestrian traffic, and available sight distance. Regardless of lighting, a roundabout intersection should be signed and marked in accordance with the *Manual on Uniform Traffic Control Devices*. The design of roundabouts can vary greatly from project to project; therefore, specific illumination guidelines and design criteria is not appropriate. When lighted, the following features and guidance should be considered by the Designer for lighting a roundabout intersection:

- Roundabouts should be illuminated from the outside in towards the center circle. For vehicles approaching the intersection, this will improve the visibility of the central island and of the vehicles already in the circulating stream of the roundabout. Avoid placing light poles within the central island.
- Good illumination should be provided at the approach nose of splitter islands, all conflict areas where vehicles are entering the circulating stream, and at locations where traffic departs from the circulation to exit the roundabout.
- Pedestrian crossings and bicycle merging areas should be given special consideration. Light poles placed 10 to 30 feet in advance of a crosswalk is recommended to provide positive contrast on the pedestrians.
- Clear zone requirements from the *Roadside Design Guide, AASHTO* should be considered when lighting is provided. Illumination poles or masts should not be placed within small splitter islands, on the right-hand perimeter just downstream of an exit point, or on the central island directly opposite of an entry roadway.
- In rare cases when it is desired to illuminate objects within the central island, the Designer should consider using ground-level lighting that shines upward and away from the nearest edge of pavement. In these cases, a separate electrical disconnect should be provided for blackout protection.
- It is recommended that the approach and/or exit roadways serving the roundabout be illuminated up to 260 feet beyond the final trajectory changes at each exit, especially at rural sites where lighting is used.
- Short, dark areas between a series of roundabouts or dark areas between an illuminated roundabout and an existing illuminated roadway section should be avoided.

On projects developed for the Department with proposed lighting, the Designer (or consultant) should forward a set of preliminary plans to Traffic Operations, Signal and Lighting Section (TDOT.TrafficOps.SNL-Reviews@tn.gov) to determine the need (if any) for lighting, level of illumination, and pole locations at the time of the preliminary plans submittal.

2-1008.00 LANDSCAPING GUIDELINES FOR ROUNDABOUTS

Properly designed landscaping typically increases the efficiency of the roundabout and improves safety of the circulatory intersection. For urban areas, landscaping may be requested by the local entity to enhance the aesthetics of the intersection. Landscaping can improve intersection performance and safety for the following reasons:

- When used at the right and/or left of the approaches, vehicle speeds are typically reduced due to the tunneling effect perceived by motorists.
- Landscaping makes the central island more conspicuous (noticeable) to drivers; whereby indicating to the approaching driver that they cannot pass straight through the intersection.

TDOT ROADWAY DESIGN GUIDELINES
CHAPTER 2 GEOMETRIC DESIGN CRITERIA

English

Revised: 04/24/23

- Properly placed landscaping obstructs the motorists' view across the intersection; whereby forcing drivers to look in the standard left and right directions.
- In high pedestrian areas, landscaping will tend to channel pedestrians to designated crosswalk locations reducing unwanted pedestrian/vehicle conflict points. This is vital since roundabouts may not have pedestrian push-buttons and signals.

The central island, large splitter islands, and the approaches to the intersection present opportunity for landscaping; however, the landscaping should be designed to optimize safety and operation. The Designer should consider the following guidelines for developing a safe, effective, and low-maintenance landscaping plan for a roundabout:

- Maintain required stopping and intersection sight distance for the circulatory roadway around the central island. Keep the outside 6 feet of the central island (above the truck apron) free from significant landscaping features except very low-growth plants and grass (preferable) to maintain sight distance. In no case should this width be less than 6 feet; however the actual width may be greater and should be determined by computing the required circulatory roadway and intersection sight distances.
- Avoid landscaping in splitter islands except where the island is long and/or exceptionally wide. When used, the maximum height of landscaping features at maturity should not exceed 30 inches measured from the nearest pavement edge to the tallest point of the mature vegetation, including the curb height. See RD11-SD-2.
- Consider low-maintenance, drought-resistant grasses and hearty plant material in the raised center island, larger splitter islands, and buffer strips. Minimize fixed objects (trees, large boulders, walls, etc.) in as much as possible. Avoid trees with large canopies. The central island should be considered similar to a median, with all objects being breakaway.
- Splitter islands can be hardscaped (concrete, textured concrete, brick pavers, etc.) to reduce maintenance and maintain required sight distances. A hardscaping that is different from the sidewalk or shared-use path is recommended to ensure that pedestrians and bicyclists do not confuse the splitter island with a sidewalk.
- The Designer should avoid placing benches, street furniture, or plaques and monuments with small text in the central island so as not to attract pedestrians to the center island.

When landscaping is requested by the local government, the Designer should coordinate with the local agency for development of the landscaping plans and for specific landscaping features that may be requested at the intersection, especially for those located in urban or historic districts. Additional guidance regarding landscape design may be found in the [TDOT Landscape Design Guidelines](#), found on the [TDOT Environmental Division webpage](#).

TDOT ROADWAY DESIGN GUIDELINES
CHAPTER 2 GEOMETRIC DESIGN CRITERIA

English

Revised: 04/24/23

SECTION 11 – ROAD RECONFIGURATION AND ROAD DIET

2-1100.00 ROAD RECONFIGURATION

Road Reconfiguration is repurposing the existing available pavement width to improve safety and to accommodate non-motorized users to achieve systemic improvements by modifying roadway geometric design elements (lane width, number of lanes, shoulder width and speed). Road Reconfiguration provides the opportunity to address existing safety issues or multimodal accommodation in an expedited and cost-effective manner by using pavement markings only. Additional information regarding Multimodal Design can be found in the Roadway Design Guidelines [Chapter 3 – Multimodal Design Guidelines](#).

A Road Reconfiguration shall maintain the current Level of Service (LOS) without negatively impacting operational safety of the motorist and non-motorized users (both existing and new). All road reconfigurations must meet TDOT's roadway typical section design standards (Roadway Standard Drawing RD11-TS-Series) or require completion of [Design Exception request](#) or a [Design Waiver request](#) justifying the reason for the deviation. All Design Exception requests will be addressed by the Roadway Design Division as outlined under *Chapter 2-105.00 Design Exception Requests* and *Design Waiver requests* will be addressed by the Roadway Design Division as outlined under *Chapter 2-201.00 Design Waiver Requests*. A Road Reconfiguration request shall be coordinated with local agencies and a local agency coordination letter should be included in the Road Reconfiguration request.

2-1101.00 ROAD DIET

A Road Diet is the reduction of vehicular lanes of an existing four or six lane roadway to a three or five lane roadway to improve safety, and/or accommodate non-motorized users to achieve systemic improvements. Roadway projects identified as a candidate for a Road Diet must be evaluated using the Road Diet Guidance Manual. The identified project shall apply methods from [Chapter 3](#) concerning the American's with Disabilities Act. See the Road Diet Guidance Manual for evaluation criteria, required submittals, and more information about the process.

SECTION 12 – DRIVEWAYS

2-1200.00 DRIVEWAYS

TDOT ROADWAY DESIGN GUIDELINES
CHAPTER 2 GEOMETRIC DESIGN CRITERIA

English

Revised: 04/24/23

A driveway is defined as an improved area leading from a public road to private property. There are three types of driveways: private drives, business entrances, and field entrances. Driveways should be provided for the following:

- A. Where Existing Road is being improved
 - 1. Tie into existing driveway
 - 2. Relocate drive if connection to existing drive is too steep (see Limits of Vertical Grade)
 - 3. Tracts where there is no prior access

- B. New Roadway Construction
 - 1. Provide access to each tract if requested

All driveways on private and public side roads shall be shown on Present, Proposed, Profile, Signing and Marking, and Traffic Control sheets. The following section provides design requirements and considerations when creating a driveway. Designers will be required to add in ROW details for the driveway parcel in COGO. Designers will need to look at the grade sections to develop the correct construction easements. Designers should follow the standard guidance for construction easements of applying 10 ft for urban and 15 ft for rural. See *Figure 2-44, Rural Type Projects Typical Driveway Notation* and *Figure 2-45, Urban Type Projects Typical Driveway Notation* for examples of how to display driveways on plans. For additional information see also, [Manual for Constructing Driveway Entrances on State Highways, 2015](#) and the [Driveway Design Guide](#).

TDOT ROADWAY DESIGN GUIDELINES
CHAPTER 2 GEOMETRIC DESIGN CRITERIA

English

Revised: 04/24/23

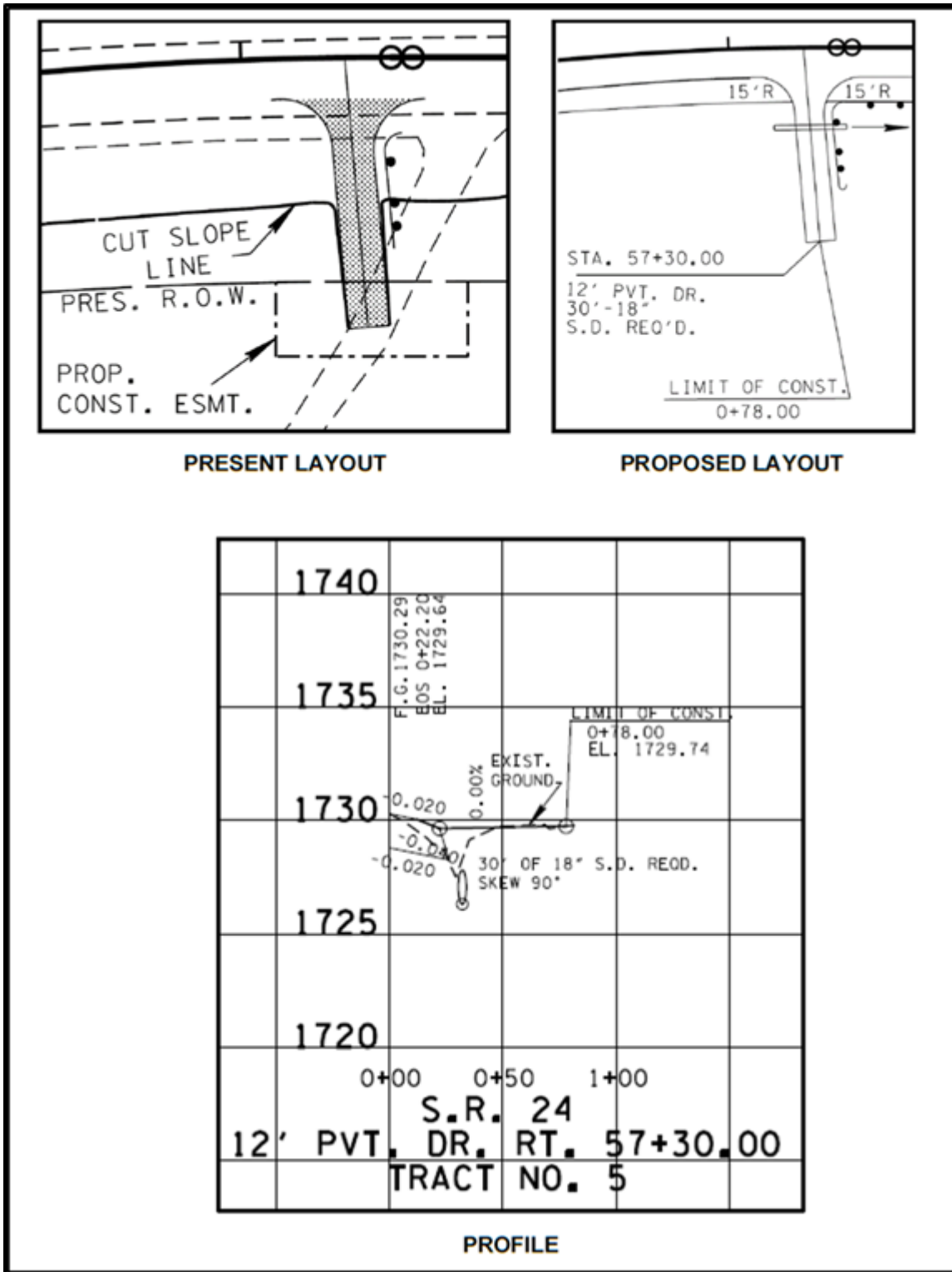

Figure 2-44
Rural Type Projects Typical Driveway Notation

Note: This figure is for layout procedure purposes only. Please refer to [Manual for Construction Driveway Entrances on State Highways, 2015](#) and Roadway Standard Drawings RP-D-15, RP-D-16 and RP-R-1 for design information.

TDOT ROADWAY DESIGN GUIDELINES
CHAPTER 2 GEOMETRIC DESIGN CRITERIA

English

Revised: 04/24/23

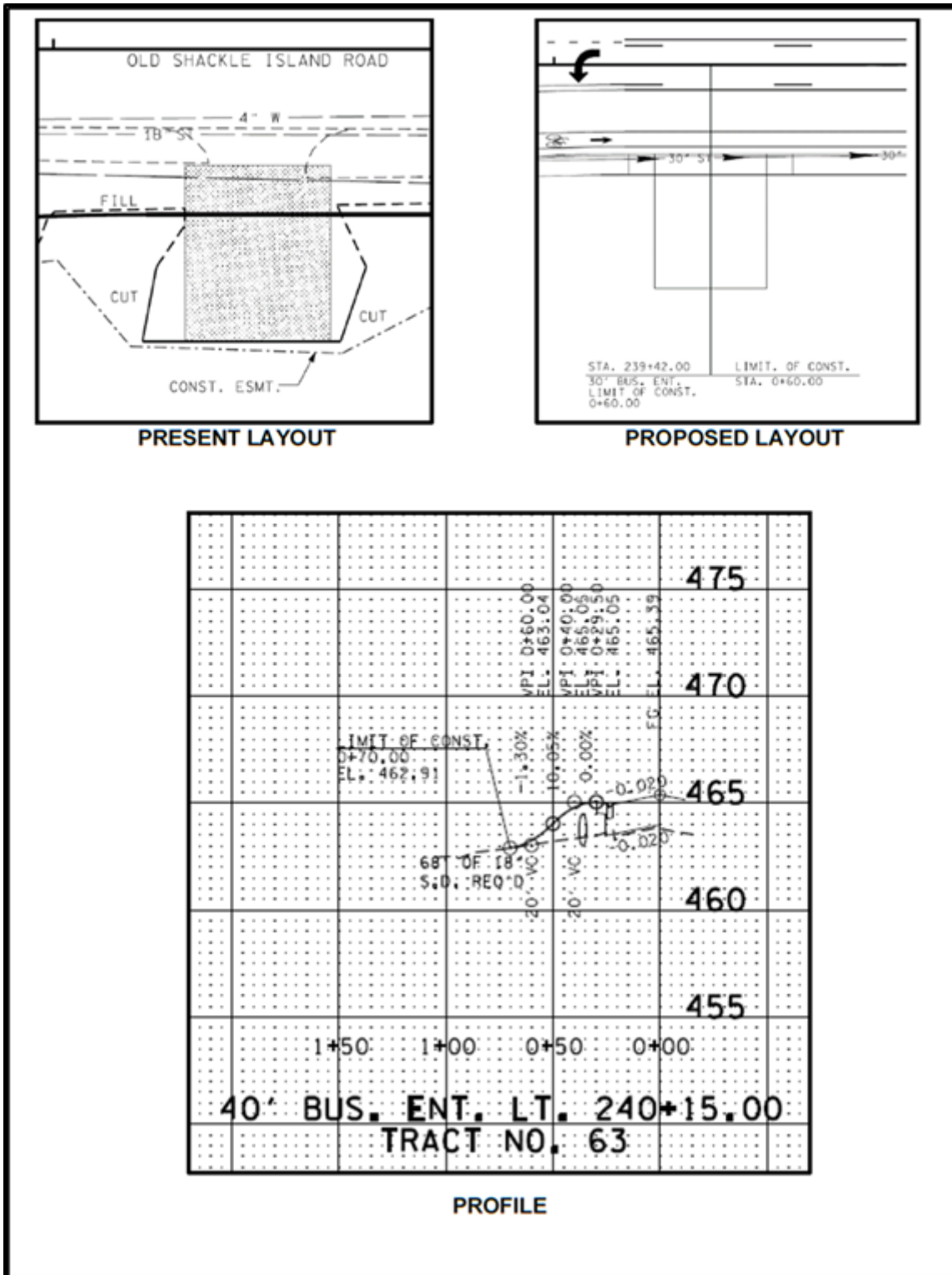

Figure 2-45

Urban Type Projects Typical Driveway Notation

Note: This figure is for layout procedure purposes only. Please refer to [Manual for Construction Driveway Entrances on State Highways, 2015](#) and Roadway Standard Drawings RP-D-15, RP-D-16 and RP-R-1 for design information. .

TDOT ROADWAY DESIGN GUIDELINES
CHAPTER 2 GEOMETRIC DESIGN CRITERIA

English

Revised: 04/24/23

2-1201.00 DRIVEWAY TYPICAL SECTION AND DESIGN CRITERIA

A new asphalt driveway section should consist of a surface, binder, and a base layer. See *Figure 2-46, Driveway Typical Section*. Where the surface of an existing drive is concrete, substitute 6 inches of concrete for surface and binder and 4 inches for base. Designers shall add a footnote for the Item Number 303-01, Mineral Aggregate, Type A Base, Grading D that notes the quantity used for driveways. When a Designer is connecting into an existing drive, the surface material should match.

If an existing drive is greater than 12 feet in width, the width of the proposed drive shall be equal to the existing width but not greater than the maximum allowable width, typically 40' for commercial. See Roadway Standard Drawing - RP Series for more information.

If an existing drive is gravel, surfacing will be for one shoulder width. The remainder of the drive will be replaced with gravel to the touchdown point.

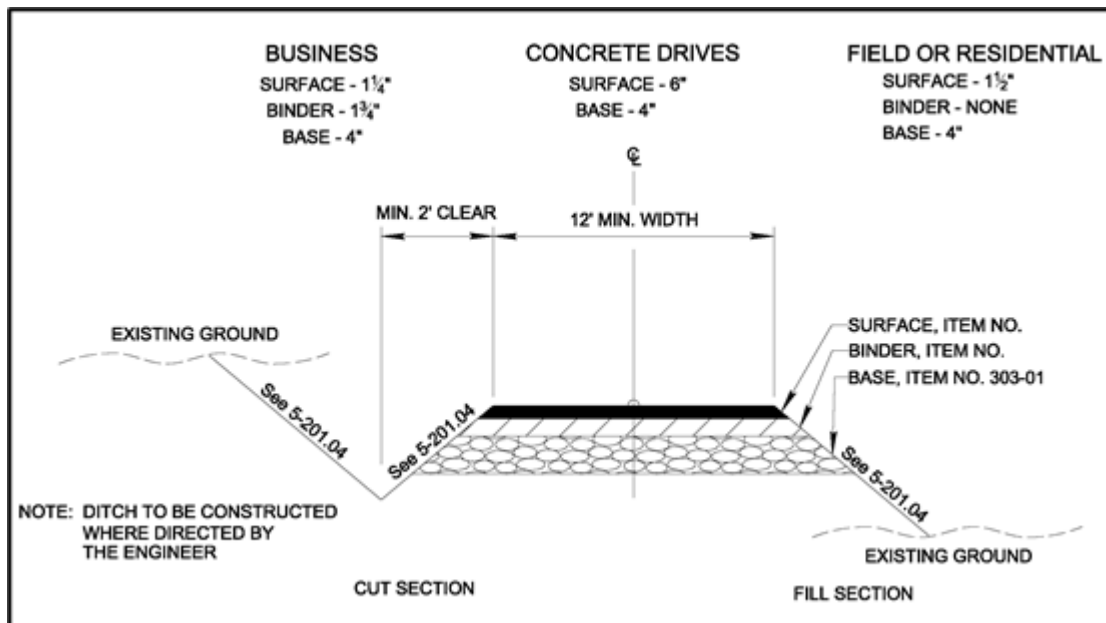

Figure 2-46
Driveway Typical Section

2-1201.01 DRIVEWAY VERTICAL CURVES

Vertical grade limits vary between rural and urban designs, both for private drives and field entrances and for business entrances. See Table 2-14 for maximum vertical grade limits. Vertical curve K values are 1 for a crest curve and 2 for a sag curve. See, Sections 5.3.1 through 5.3.3 of the [Manual for Constructing Driveway Entrances on State Highways, 2015](#) and Roadway Standard Drawing RP-R-1 for additional vertical curve information.

TDOT ROADWAY DESIGN GUIDELINES
CHAPTER 2 GEOMETRIC DESIGN CRITERIA

English

Revised: 04/24/23

Rural Roadways Vertical Grade Limits	
Private Drives & Field Entrances	15% maximum
Business Entrances	8% Maximum
Urban Roadway Design Vertical Grade Limits	
Private Drives and Field Entrances	10% Maximum
Business Entrances	8% Maximum

Table 2-14
Vertical Grade Limits for Rural and Urban Roadways

2-1201.02 DRIVEWAY HORIZONTAL CURVES

For private drives, business entrance, and field entrance design on rural roadways, horizontal curve radius limits are 10 ft minimum and 20 ft maximum. For private drives, business entrance and field entrance design on urban roadways, horizontal curve radius limits are 5 ft minimum and 15 ft maximum. See [Manual for Constructing Driveway Entrances on State Highways, 2015](#), Section 5.1.3 and Roadway Standard Drawing RP-R-1 for additional horizontal curve information.

2-1201.03 DRIVEWAY CROSS SLOPE

Positive drainage should be maintained throughout the length of the driveway. One driveway edge may be higher than the other or the center line may be higher than the edges, creating driveway cross slope. Where the driveway and sidewalk intersect, the driveway cross slope is the same as the sidewalk grade.

2-1201.04 DRIVEWAY EDGE

A driveway edge should be clearly defined and visible to all users. The designer should avoid sudden drop-offs along the edge of drive. Fixed objects such as utility poles, fire hydrants, and drainage inlets should be set back from the edge of the driveway and from the edge of the roadway. If there is a side drain and the side drain is within the clear zone, maintain mainline side slopes through the safety endwall. If a parallel side drain is not required, 2:1 slopes may be used beyond the driveway radius. Designers should review the roadway and driveway slopes to ensure that a non-traversable slope within the clear zone is not created when the drop off is five foot or more.

TDOT ROADWAY DESIGN GUIDELINES
CHAPTER 2 GEOMETRIC DESIGN CRITERIA

English

Revised: 04/24/23

2-1201.05 DRIVEWAY APRONS

Right-of-Way plans for new construction or reconstruction projects shall accommodate the appropriate driveway aprons. The driveway standard drawings have been modified to provide Public Right-of-Way Accessibility Guidelines (PROWAG) compliant cross-slope for sidewalks through driveway aprons. For curb and gutter sections, this typical section is to begin at the back edge of the proposed or future sidewalk. The aprons have also been modified to provide for a better turning radius into the drive. See Roadway Standard Drawings RP-D-15 and RP-D-16.

2-1201.06 DRIVEWAY SIDE DRAINS

A side drain is a pipe located under a driveway, at the toe of slope in a fill section or in the ditch line in a cut section. The drainage pipe (side drain) shall be a minimum of eighteen inches (18") in diameter. The side drain cover should be 12 inches from the top of pipe to the bottom of the driveway base. Endwalls are required if the drainage pipe falls within the clear zone. The pipe slope should be 0.5% to 2% slope for proper flow. See Roadway Standard Drawings D-SEW-1A, D-SEW-12D, and RP-R-1 for additional information. See the [Driveway Design Guide](#) for side drain calculation information.

2-1202.00 MULTIMODAL ROADWAY DESIGN IN DRIVEWAYS

Multimodal components must be considered when designing driveways. Driveway guidance has traditionally focused on accommodating motor vehicles, but now emphasis is also being placed on managing access and accommodating pedestrians and cyclists. The design of a driveway affects the safety and mobility of motorists, cyclists, and pedestrians. See [Chapter 3 Multimodal Design](#) for additional information for multimodal components.

2-1203.00 GUIDELINES FOR CONSTRUCTION AND RESURFACING OF DRIVEWAYS ON HIGHWAY PROJECTS

2-1203.01 GENERAL

For new construction projects, new driveway entrances shall be located and designed in accordance to the TDOT [Manual for Constructing Driveway Entrances on State Highways, 2015](#) and to the current Roadway Standard Drawings RP-D-series and RP-R-series. For retrofit, resurfacing, and reconstruction projects the designer should leave existing driveway entrances in place if the existing locations do not affect operational safety. It is important to identify potential conflicts during field reviews and have Traffic Operations Division evaluate the potential

TDOT ROADWAY DESIGN GUIDELINES
CHAPTER 2 GEOMETRIC DESIGN CRITERIA

English

Revised: 04/24/23

conflicts. This must be done early in the design process because if an existing driveway entrance needs to be relocated it can affect Right-of-Way acquisition.

DEFINITION OF TERMS

Paved Shoulder Width - The width of the shoulder paved as part of the project.

Paver Width - The width of asphalt paving machine used on mainline paving with maximum width of 12 feet or to extend beyond Right-of-Way limit.

Normal Right-of-Way – The areas of land including the normal slopes of the highway and the public road intersection.

2-1203.02 RESURFACING

- A. Where directed by the TDOT Engineer, the Contractor shall be required to shape public side roads, business entrances, and private drives, as well as clean existing drains before placing materials. All costs are to be included in the price bid for other items of construction.
- B. Resurfacing projects on roadways with shoulders and ditches (no curb or gutter):
 - 1. Private driveways, field entrances, and business entrances will be resurfaced a paver width as a minimum. A pavement taper to transition the new pavement shall be required, it shall be based on an additional 1 foot of width per inch depth of pavement. If the shoulder is narrow enough that the sum of the shoulder and the transition are less than a paver width (lane width), the transition shall occur within the paver width. If the sum of the shoulder and the transition is greater than a paver width, the transition shall occur outside of the paver width.
- C. Resurfacing projects on roadway with urban curb and gutters
 - 1. Residential driveways and business entrances shall have a minimum width of material not less than one foot used in the transition to feather the pavement edge.
- D. In all cases, the length of the pavement transition, the thickness and width of the resurfacing and any additional pavement materials shall be as directed by the TDOT Engineer.
- E. During resurfacing projects, it is the Department's intent to evaluate the repair or installation of curb ramps which meet the PROWAG whenever possible as encountered through resurfacing. See [TDOT Policy Number 530-01](#) for additional information. According to TCA §54-5-202, when resurfacing or performing any maintenance work on a roadway, the Department is responsible for work from "curb to curb". Due to the limited resources of some localities, the Department will attempt to install or repair curb ramps whenever possible. The local government is responsible for maintaining sidewalks, curb ramps, etc.

TDOT ROADWAY DESIGN GUIDELINES
CHAPTER 2 GEOMETRIC DESIGN CRITERIA

English

Revised: 04/24/23

2-1203.03 NEW OR RECONSTRUCTION

A. Facilities with Full Access Control

Full access control will be maintained for the entire designated project limits.

B. Facilities with Limited Access Control

Access will be allowed at public roads and streets only. No driveways will be permitted access to the mainline project.

C. Facilities with Partial Access Control or Non-Access Control - driveways permitted:

1. Fence Opening: For Partial Access Control facilities, one 50-foot opening in the control access fence will be provided per tract remainder, unless access is provided from an intersecting road or based on physical conditions and/or conflicts with other design considerations, which prevent an access opening.
2. Existing Driveways:
 - a. For Partial Access Control facilities, one existing paved driveway per tract remainder will be replaced in-kind to a touchdown point. For Non-Access Control facilities, exiting paved driveways will be replaced in-kind to a touchdown point.
 - b. Where the existing driveway is unpaved and the proposed driveway equals or exceeds 7 percent in grade, each proposed driveway will be paved to a touchdown point or until the grade is less than 7 percent.
 - c. Where the existing driveway is unpaved and the proposed driveway is less than 7 percent in grade, each proposed driveway will be paved a shoulder width from the edge of pavement and the remainder of that driveway replaced in-kind to a touchdown point.
3. Requirements for field entrances and/or other driveways:
 - a. New driveways provided in the plans will be paved based on the 7 percent criteria. Those 7 percent or steeper in grade will be paved and those flatter than 7 percent will be covered with base stone.
 - b. Field entrances provided in the plans will be covered with base stone.
 - c. Normally, one field entrance or driveway, whichever is appropriate per tract remainder will be provided except in the following circumstances:

TDOT ROADWAY DESIGN GUIDELINES
CHAPTER 2 GEOMETRIC DESIGN CRITERIA

English

Revised: 04/24/23

1. In the project's preconstruction condition, there is a barrier to access such as a substantial cut, fill, ditch or curb.
 2. A non-gated fence where the existing frontage is totally fenced.
 3. In the project's post-construction condition, there is a substantial cut, fill, or ditch.
 - d. Small remainders and damage considerations are to be reviewed by Design Managers and the Right-of-Way Office to determine if a proposed driveway or field entrance is justified. The location, design and method of surfacing of the field entrance or driveway must be in accordance with the previously mentioned Rules. If the landowner does not desire a driveway, then it will not be included in the project.
4. All public roads will be paved to a touchdown point.