

2/3/2023 7:32:36 AM P:\StandDraw\DESIGN STANDARDS\Standards Drawings\Standard Roadway Drawings - CURRENT\In Progress\10-107.00 Design - Traffic Control IP\170.02 Work Zones IP\T-WZ-PCB4-20221209.dgn

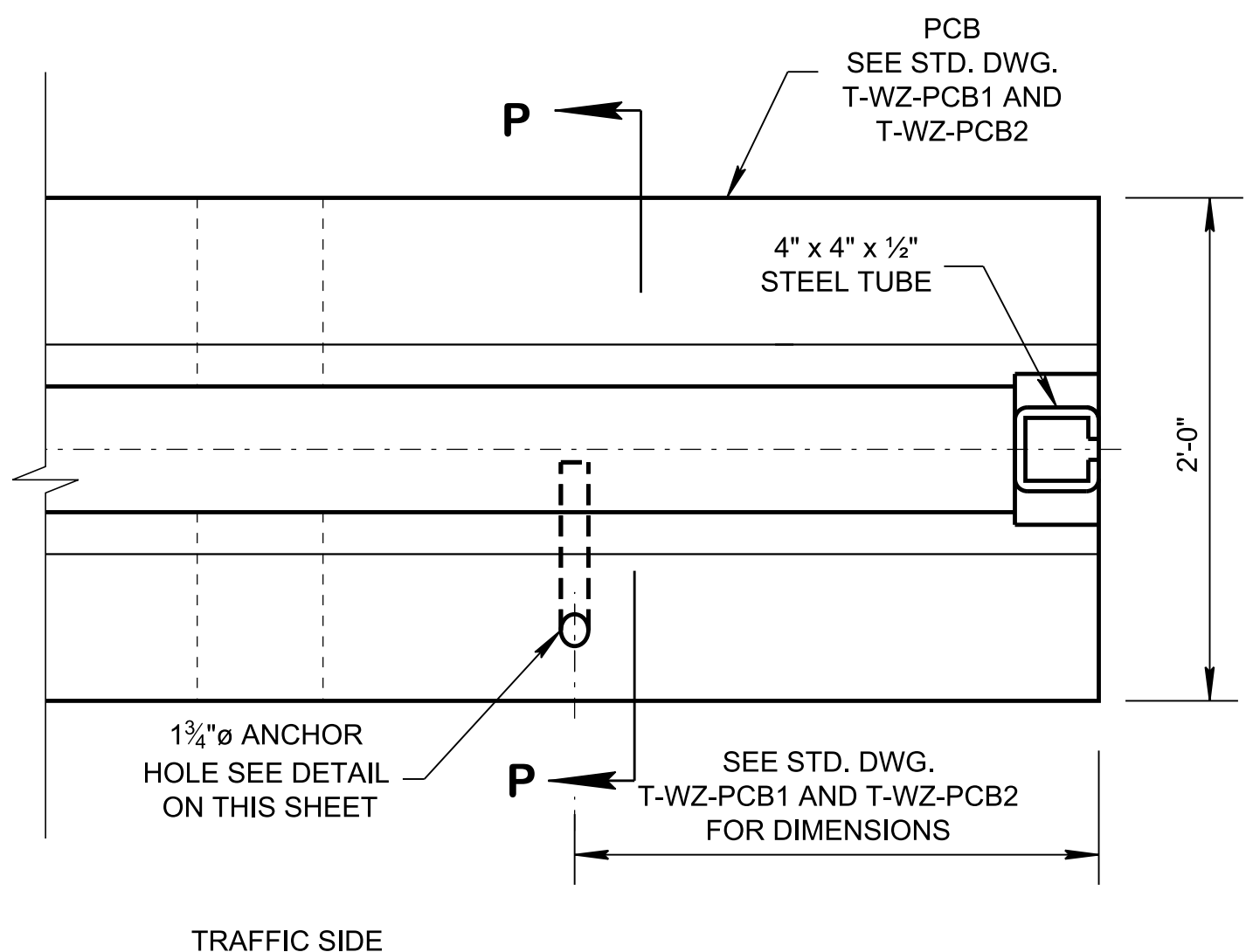

**ANCHOR HOLE PLAN VIEW**

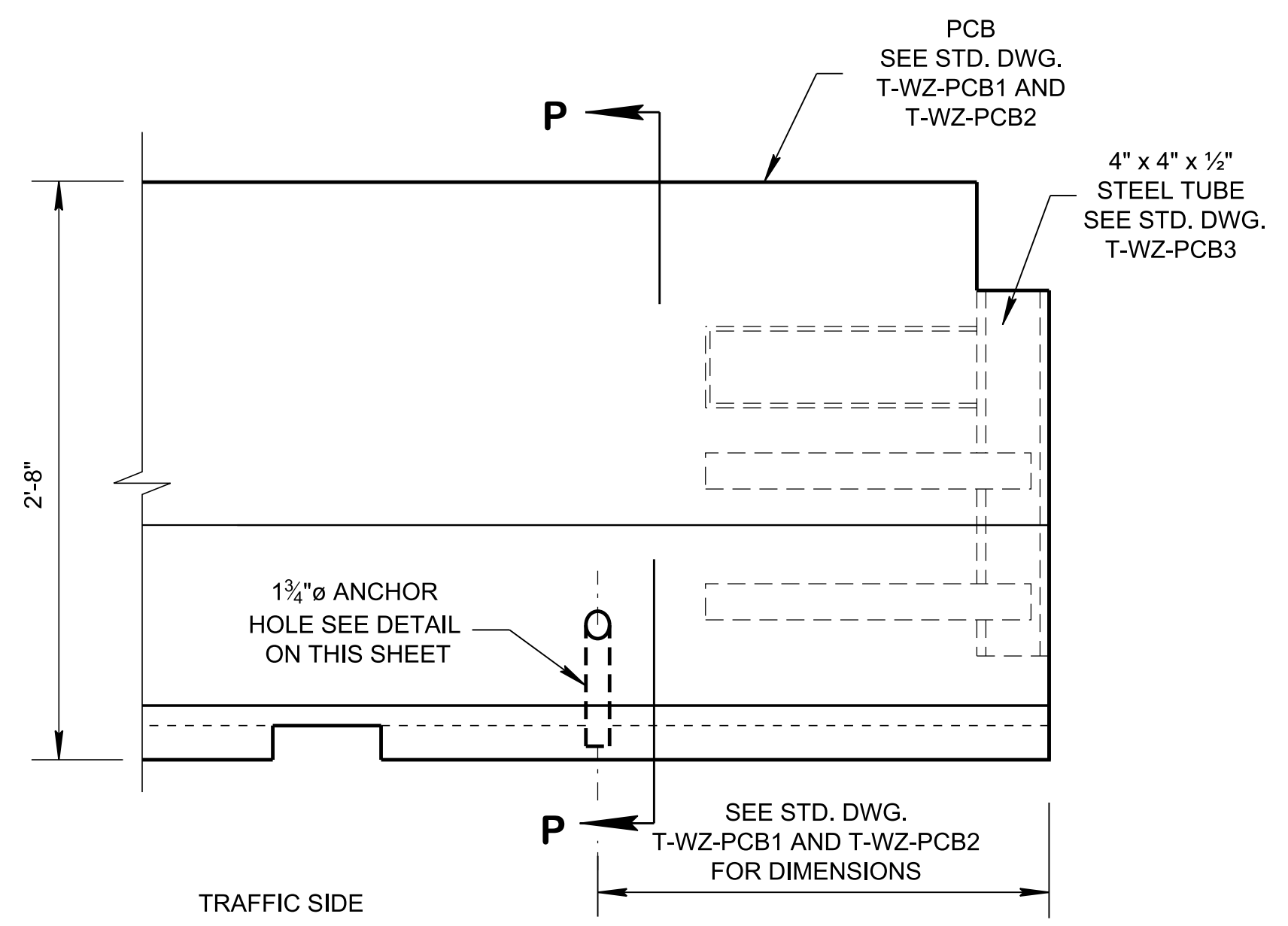

**ANCHOR HOLE ELEVATION VIEW**

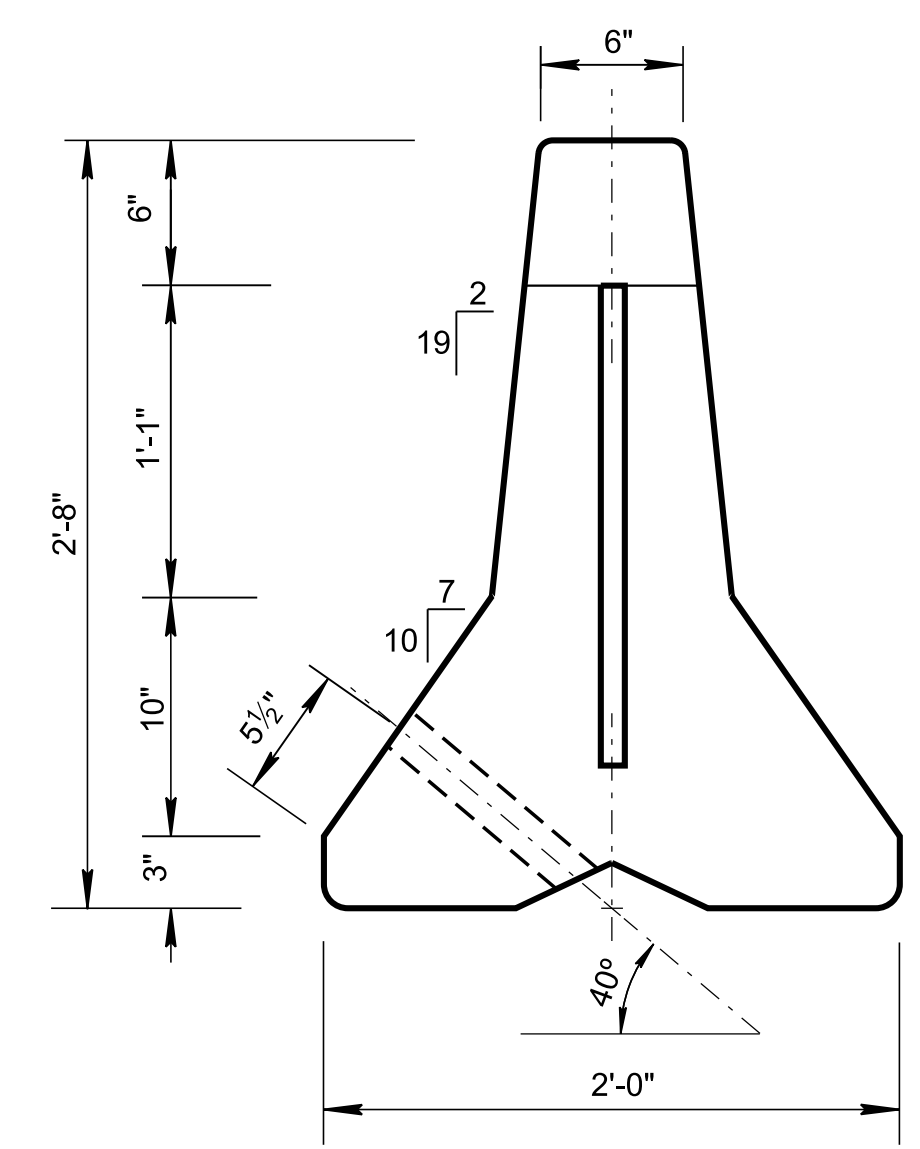

**END VIEW**

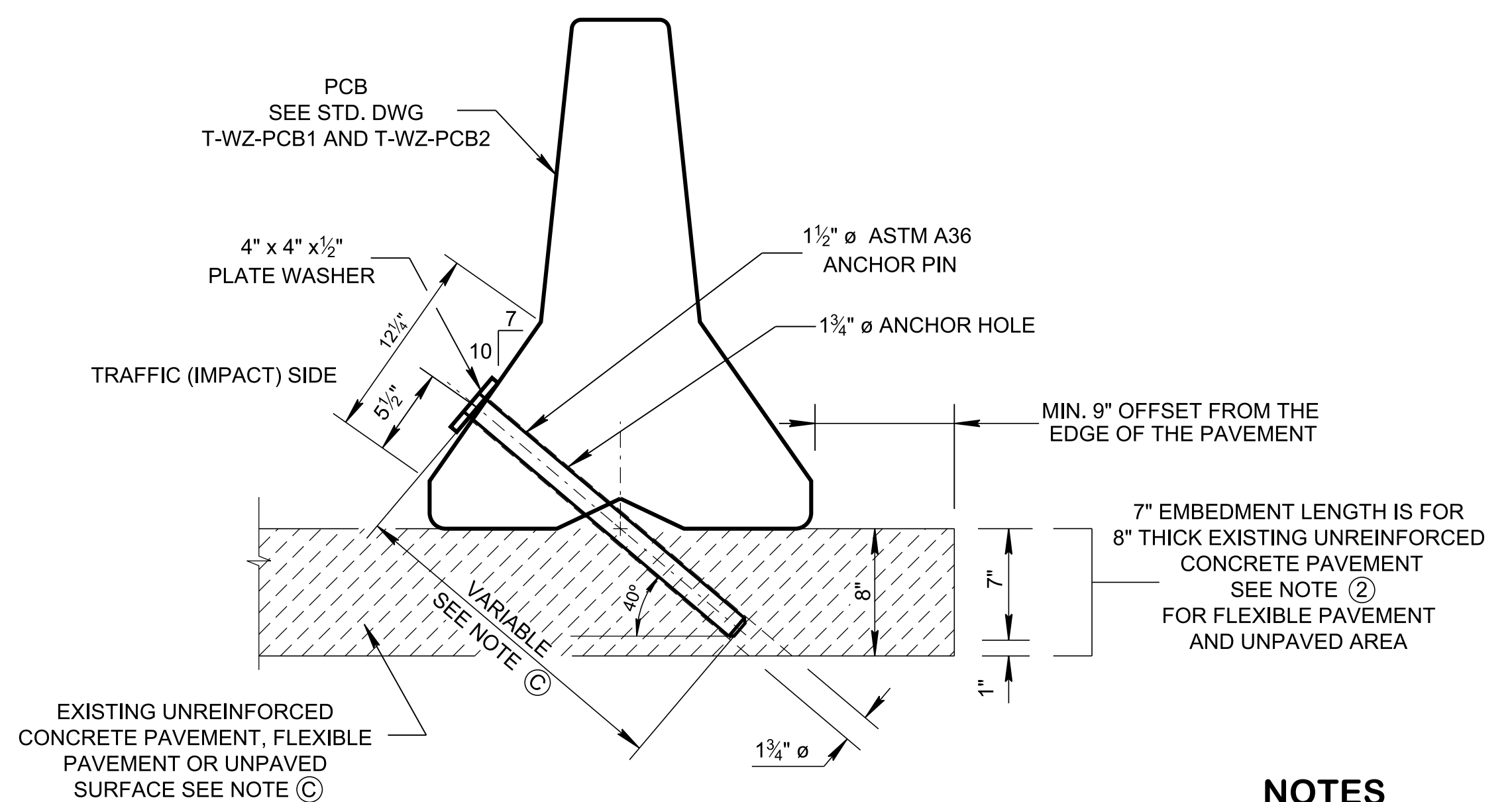

**SECTION P - P FOR ANCHOR PIN DETAIL**

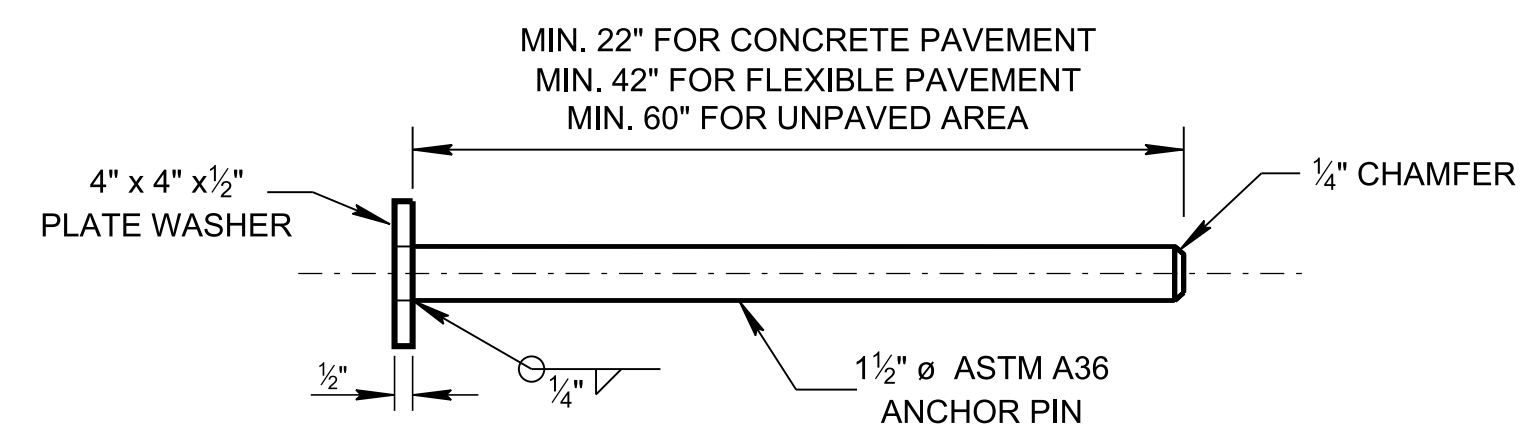

**ANCHOR PIN**

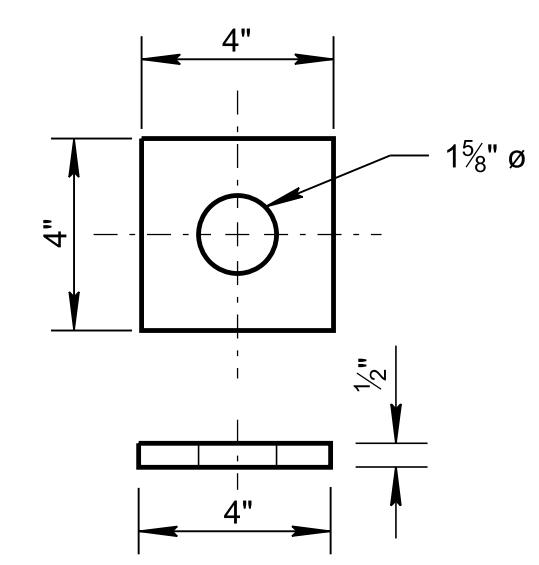

**4" x 4" x 1/2" PLATE WASHER**

**NOTES**

- ① 1 1/2"  $\phi$  PIN EMBEDDED IN EXISTING CONCRETE FLEXIBLE PAVEMENT OR UNPAVED SURFACE IN A 1 3/4"  $\phi$  HOLE, MAKE SURE THE HOLES ARE SLIGHTLY DEEPER THAN THE LENGTH OF THE ANCHOR PINS.
- ② ENSURE THAT THE LENGTH OF THE ANCHOR PIN IS SUCH THAT THE FOLLOWING MINIMUM EMBEDMENT LENGTH ARE OBTAINED.
  - 2.1. INTO CONCRETE PAVEMENT 0'-7"
  - 2.2. INTO FLEXIBLE PAVEMENT 2'-3"
  - 2.3. INTO UNPAVED AREA 3'-3"

**GENERAL NOTES**

- (A) ANCHOR PINS SHALL BE USED WITH THE FIRST AND LAST PCB SEGMENTS TO ANCHOR THE INSTALLATION AND PROVIDE TENSION FOR THE SYSTEM TO FUNCTION AS DESIGNED. ALTERNATIVE CRASH CUSHION MAY BE USED TO PROVIDE ANCHORAGE FOR THE PORTABLE CONCRETE BARRIER RAIL (SEE STANDARD DRAWING S-CC-1).
- (B) SEE STANDARD DRAWINGS T-WZ-PCB1 AND T-WZ-PCB2 FOR PORTABLE CONCRETE BARRIER RAILS.
- (C) 1 1/2" DIAMETER ASTM A36M ANCHOR PINS ANCHORED INTO DRILLED UNREINFORCED CONCRETE PAD, DRIVEN INTO FLEXIBLE PAVEMENT AND UNPAVED SURFACE. ANCHOR PINS SHALL BE PLACED ON THE TRAFFIC SIDE OF THE BARRIER. WHEN ANCHOR PINS ARE IN PLACE, THEY WILL NOT PROJECT ABOVE THE PLANE OF THE CONCRETE SURFACE OF THE BARRIER.
- (D) THE PERFORMANCE OF DROP PIN ANCHORAGE WITH PCB HAS BEEN EVALUATED AS A ROADSIDE SAFETY RESEARCH POOLED FUND STUDY TPF-5(114) AND DOCUMENTED PER TEST NO. 610231-01.1.
- (E) THE PINNED DEFLECTION FOR THIS DEVICE UNDER MASH TL-3 HAS BEEN DETERMINED TO BE 1". BASED ON THE 1" DEFLECTION CONSTRUCTION ACTIVITIES WITHIN THE 1' ZONE BEHIND THE PCB SHOULD BE AVOIDED. IF CONSTRUCTION ACTIVITIES CANNOT BE AVOIDED WITHIN THE 1' ZONE DIRECTLY BEHIND THE PCB, THE PCB SHALL BE PINNED ACCORDING TO THIS STANDARD DRAWING.
- (F) FOR INSTALLATION ON BRIDGE DECK, REFER TO BRIDGE PLANS FOR NECESSARY MODIFICATION AS REQUIRED AND DIRECTED BY THE ENGINEER.
- (G) AFTER REMOVAL OF THE BARRIER RAIL, FILL THE HOLES IN FLEXIBLE PAVEMENT OR UNPAVED AREAS, AND CONCRETE PAVEMENT AS DIRECTED BY THE ENGINEER.
- (H) PAYMENT FOR ANCHOR PINS WILL BE INCLUDED IN THE UNIT PRICE OF PORTABLE BARRIER RAIL AND PORTABLE BARRIER RAIL, REDUCED DEFLECTION ITEM NUMBERS.

APPROVED BY FHWA (ALL OTHERS APPROVED BY TDOT)

STATE OF TENNESSEE  
STANDARD DRAWING  
DEPARTMENT OF TRANSPORTATION

PORTABLE CONCRETE BARRIER RAIL ANCHOR PIN DETAILS