

TOP VIEW

BOTTOM VIEW

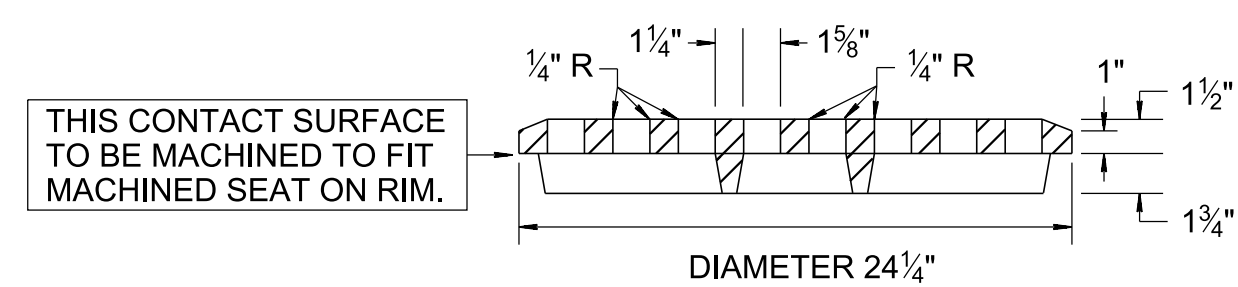

SECTIONAL VIEW

**TYPE A COVER WITH OPEN GRATE**  
(WEIGHT OF COVER - 150 POUNDS)

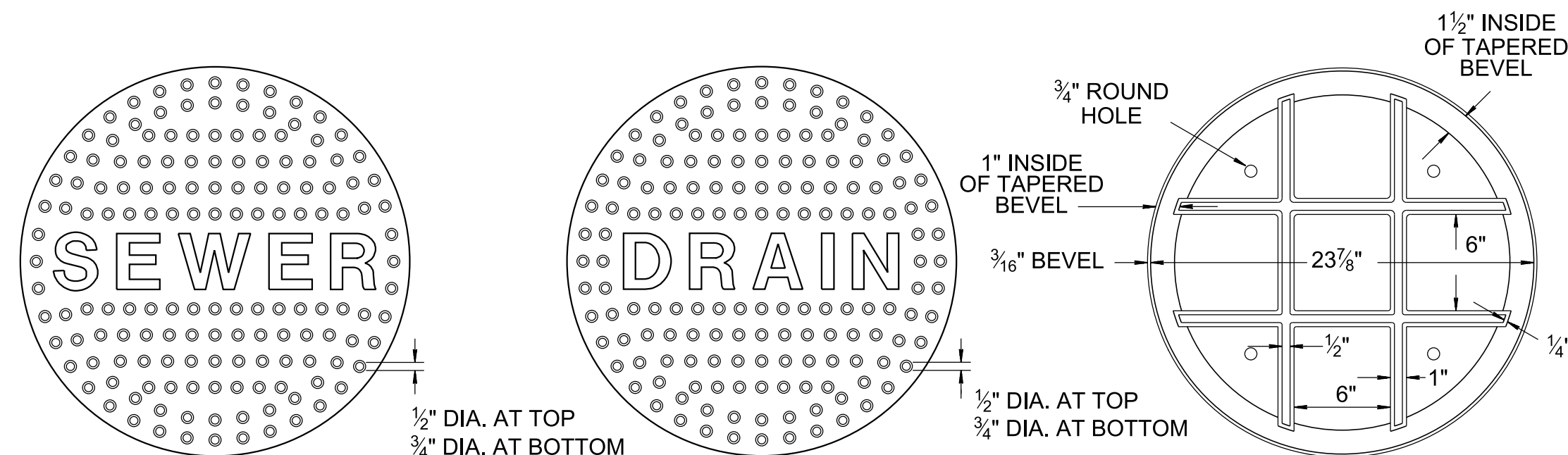

TOP VIEW

TOP VIEW

BOTTOM VIEW  
FOR BOTH TYPE B  
AND C COVERS

**TYPE B COVER**  
(SANITARY SEWER)

**TYPE C COVER**  
(STORM SEWER)

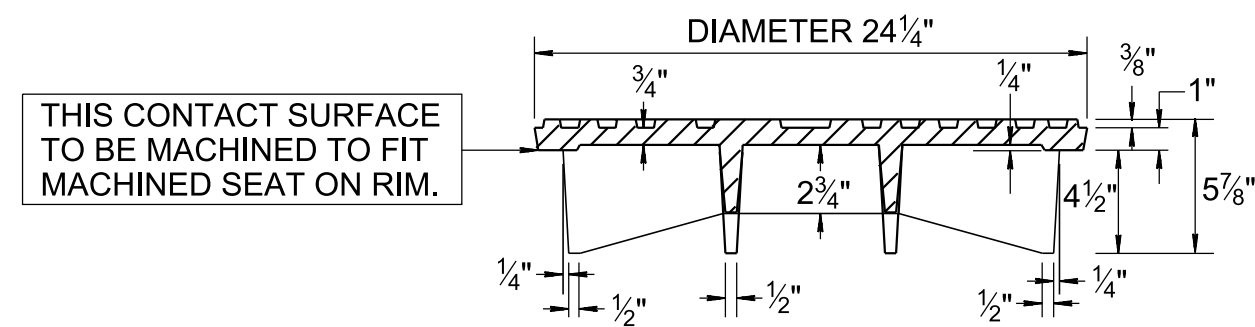

SECTIONAL VIEW FOR TYPE B AND C

**TYPE B AND C COVERS**  
(WEIGHT OF EITHER COVER - 165 POUNDS)

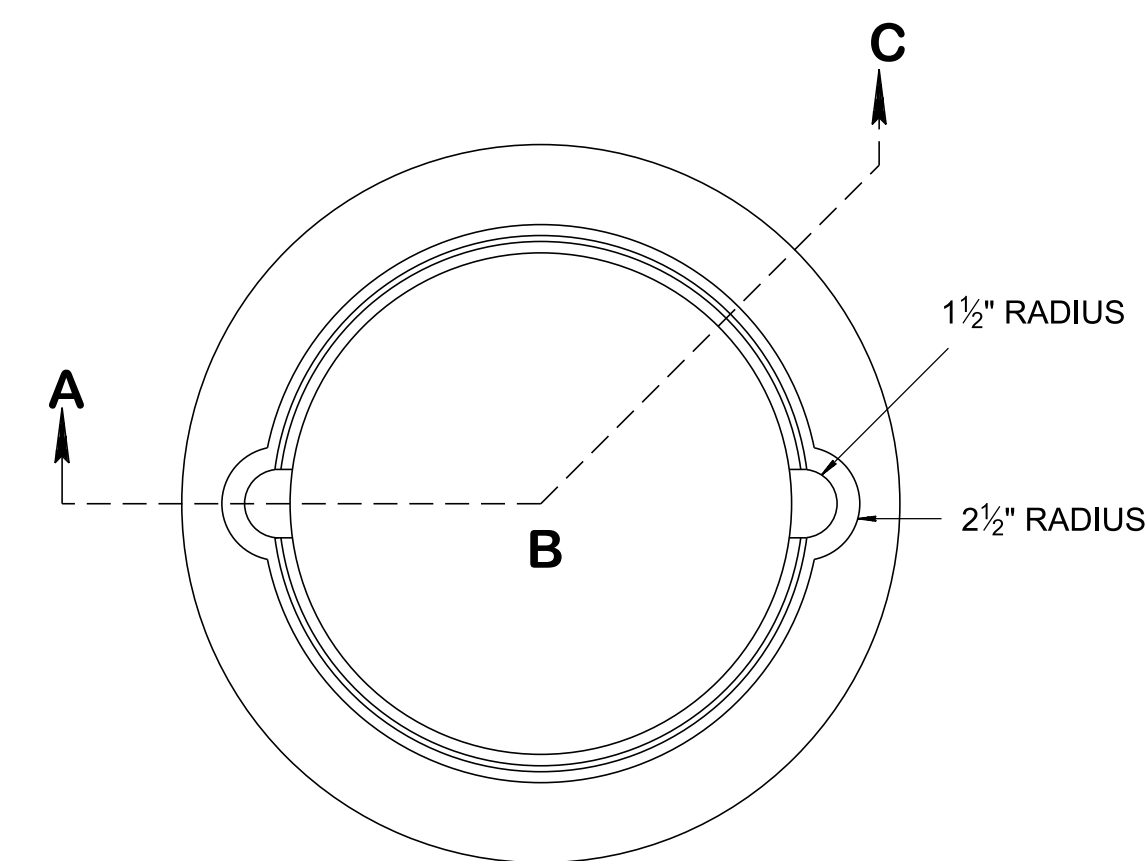

TOP VIEW

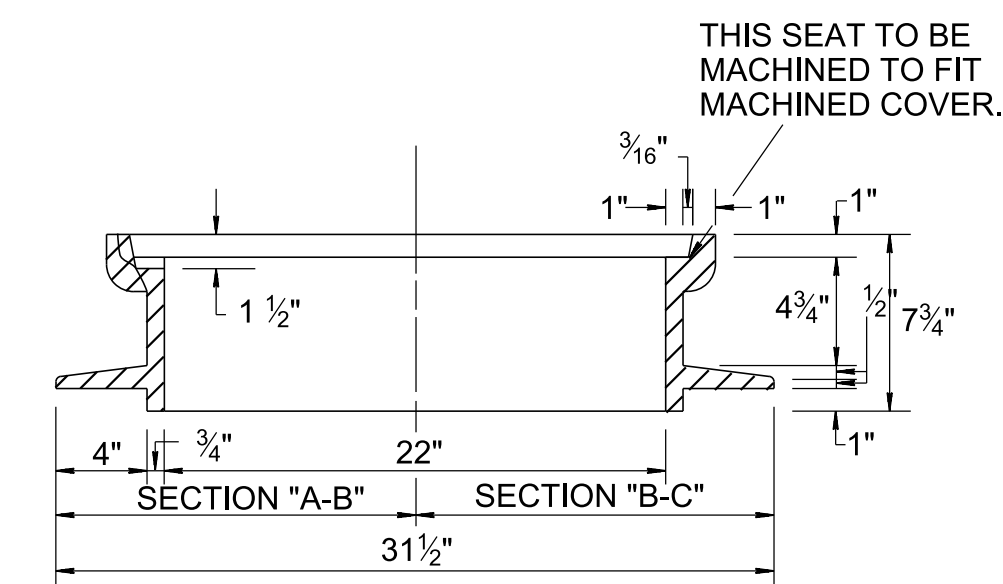

SECTIONAL VIEW

**MANHOLE RIM FOR TYPE A, B AND C COVERS**  
(WEIGHT OF RIM-229 POUNDS)

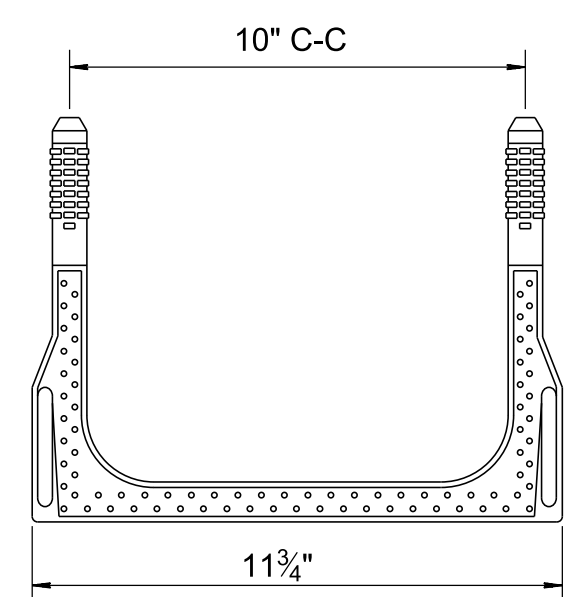

PLAN VIEW

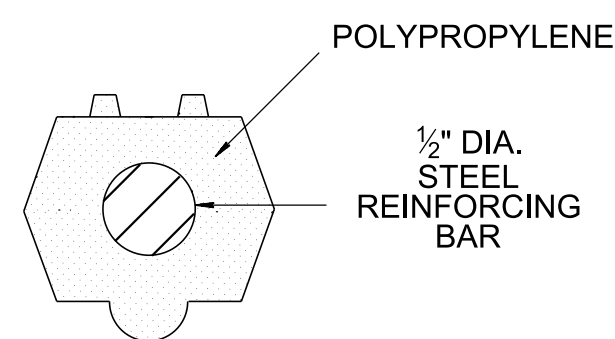

SECTIONAL VIEW

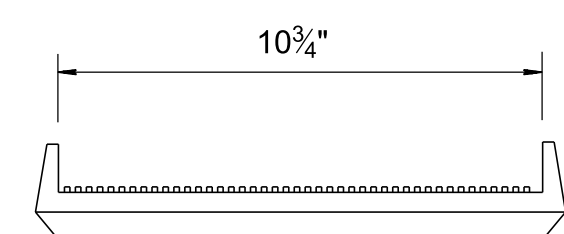

FRONT VIEW

**10 INCH PLASTIC MANHOLE STEP**

**MATERIAL SPECIFICATIONS**

THE POLYPROPYLENE, CONFORMING TO AN ASTM D-4101 SPECIFICATION, IS INJECTION MOLDED AROUND A 1/2" ASTM A-615 GRADE 60 STEEL REINFORCING BAR. THIS STEP EASILY MEETS THE REQUIREMENTS OF ASTM C-478, AASHTO M-199 AND OSHA INSTRUCTION STD. 1-1-9.

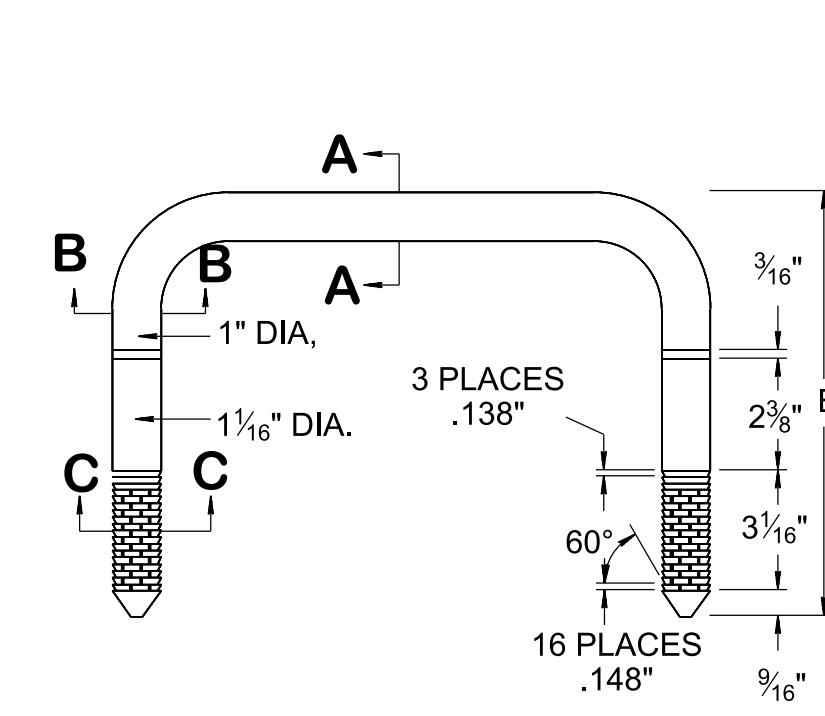

PLAN VIEW

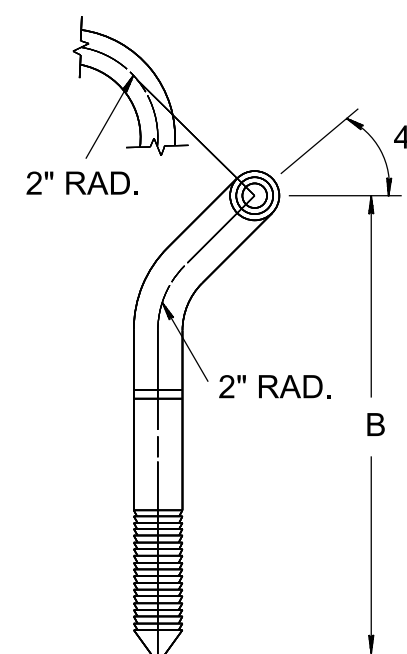

SECTION A-A

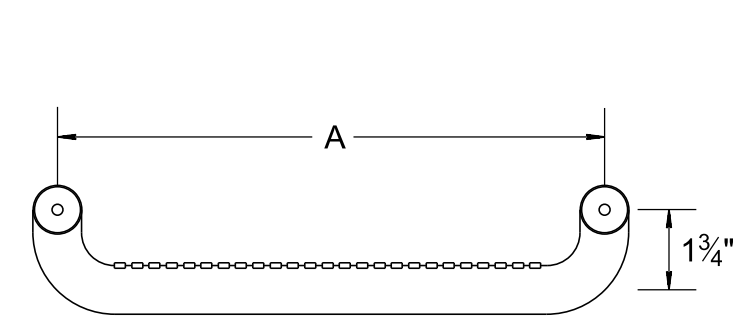

FRONT VIEW

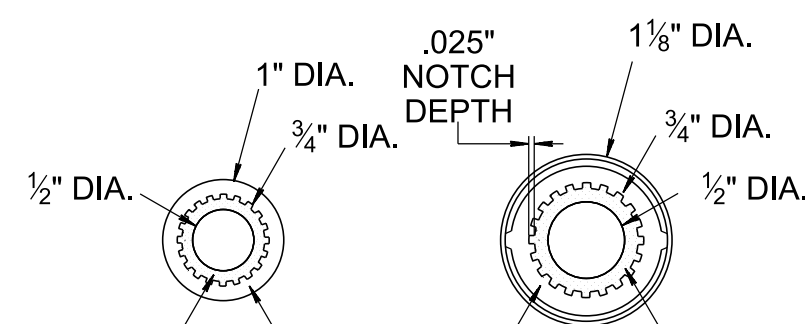

SECTION B-B

SECTION C-C

**POLYETHYLENE COATED ALUMINUM STEPS**

WIDTH OF STEP TABLE	
DIMENSION A	DIMENSION B
12"	8 3/4"
14"	8 3/4"
16"	8 3/4"
16"	9 7/8"

**MATERIAL SPECIFICATIONS**

- ① ALUMINUM: 6351-T6, CSA-S157-1969(CSA-HA5)
- ② POLYETHYLENE: LOW DENSITY, VIRGIN MATERIAL.

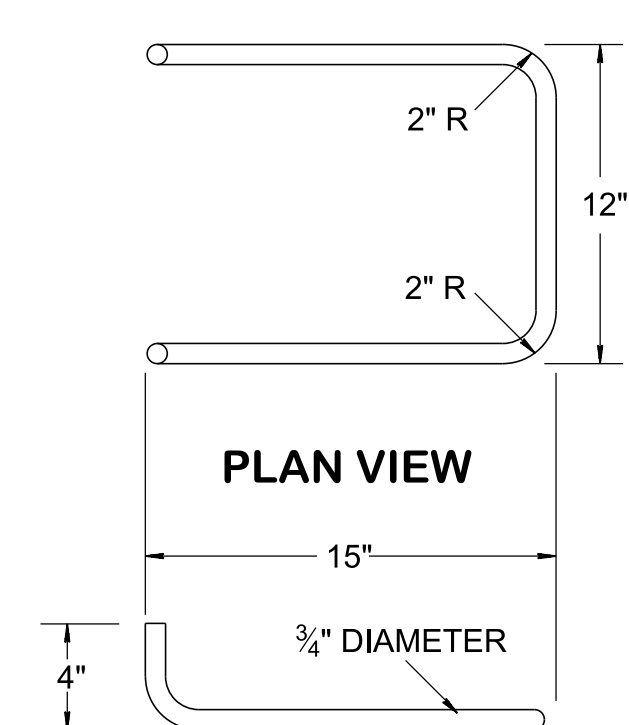

PLAN VIEW



SIDE VIEW

**WROUGHT IRON STEPS**

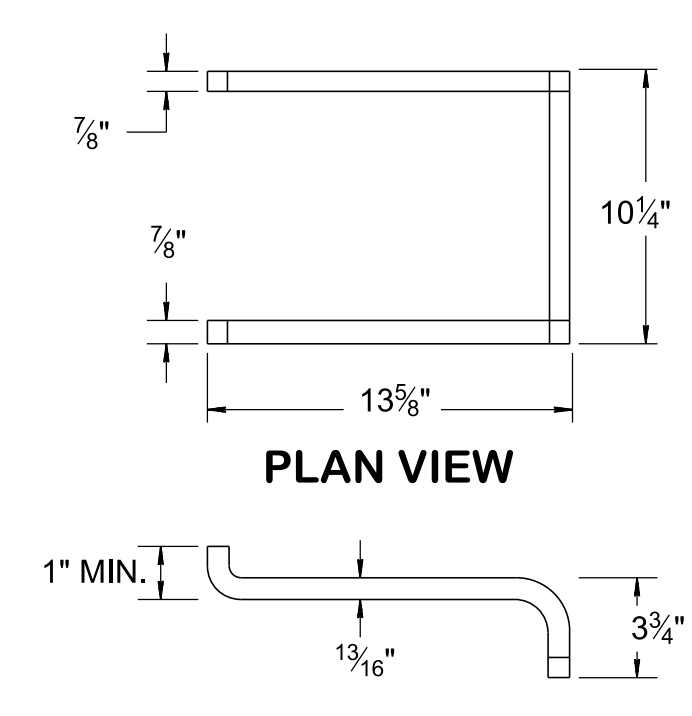

PLAN VIEW



SIDE VIEW

**ALUMINUM STEPS**  
(FOR USE WITH BRICK MASONRY MANHOLES ONLY)

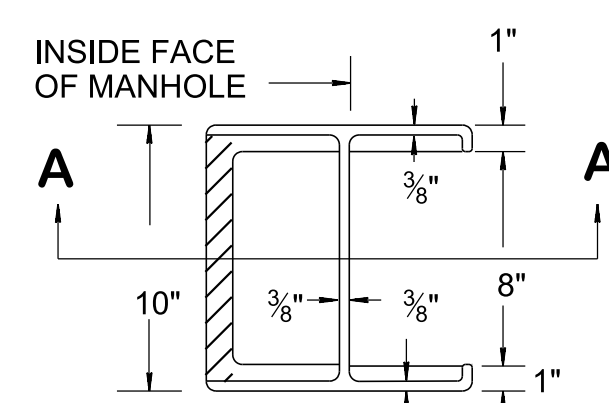

PLAN VIEW

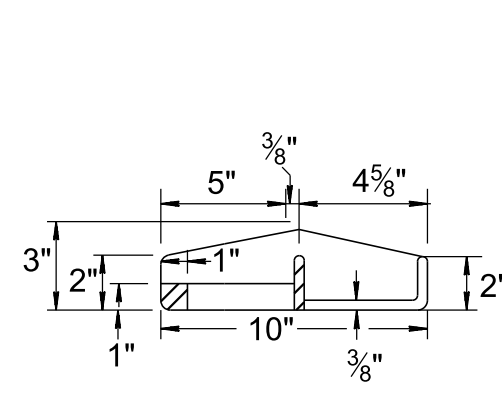

SECTION A-A

**CAST-IRON STEPS**

APPROVED BY FHWA  
(ALL OTHERS APPROVED BY TDOT)

STATE OF TENNESSEE  
STANDARD DRAWING  
DEPARTMENT OF TRANSPORTATION

STANDARD  
NO. 3 MANHOLE  
CASTINGS & STEPS

- REV. 1-15-73: USE OF ALUMINUM STEPS RESTRICTED.
- REV. 1-01-76: CHANGED DRAWING NUMBER FROM S-M-3 TO D-MH-4 (CASTINGS DETAILS ADAPTED FROM OLD DRAWING NUMBER S-M-2a).
- REV. 7-17-81: CORRECTED THICKNESS ON ALUMINUM STEP. DELETED NOTE REGARDING STEP SUBSTITUTION.
- REV. 7-11-88: ADDED POLYETHYLENE COATED ALUMINUM STEPS.
- REV. 2-14-91: REDREW AND REORGANIZED SHEET. ADDED STEEL REINFORCED COPOLYMER POLYPROPYLENE PLASTIC MANHOLE SAFETY STEP.
- REV. 5-27-01: GENERAL REVISION.
- REV. 8-01-12: GENERAL REVISION.
- REV. 02-20-2020: REDREW SHEET.