

SECTION E-E
ELEV. VIEW IS PROVIDED ON STANDARD DRAWING D-CB-99 SHOWING REINFORCEMENT REQUIREMENTS AROUND PIPE OPENINGS

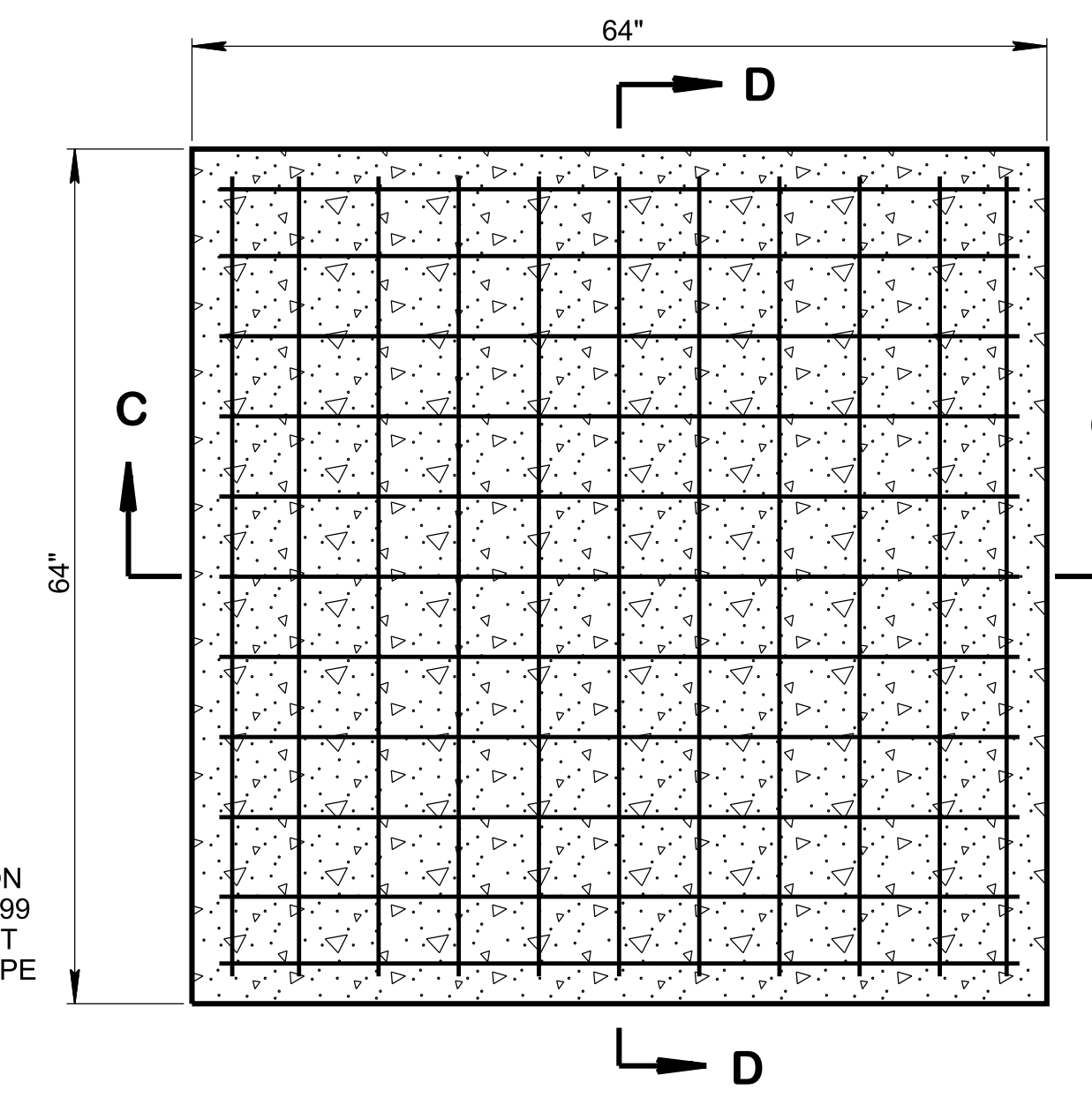

LID REINFORCING

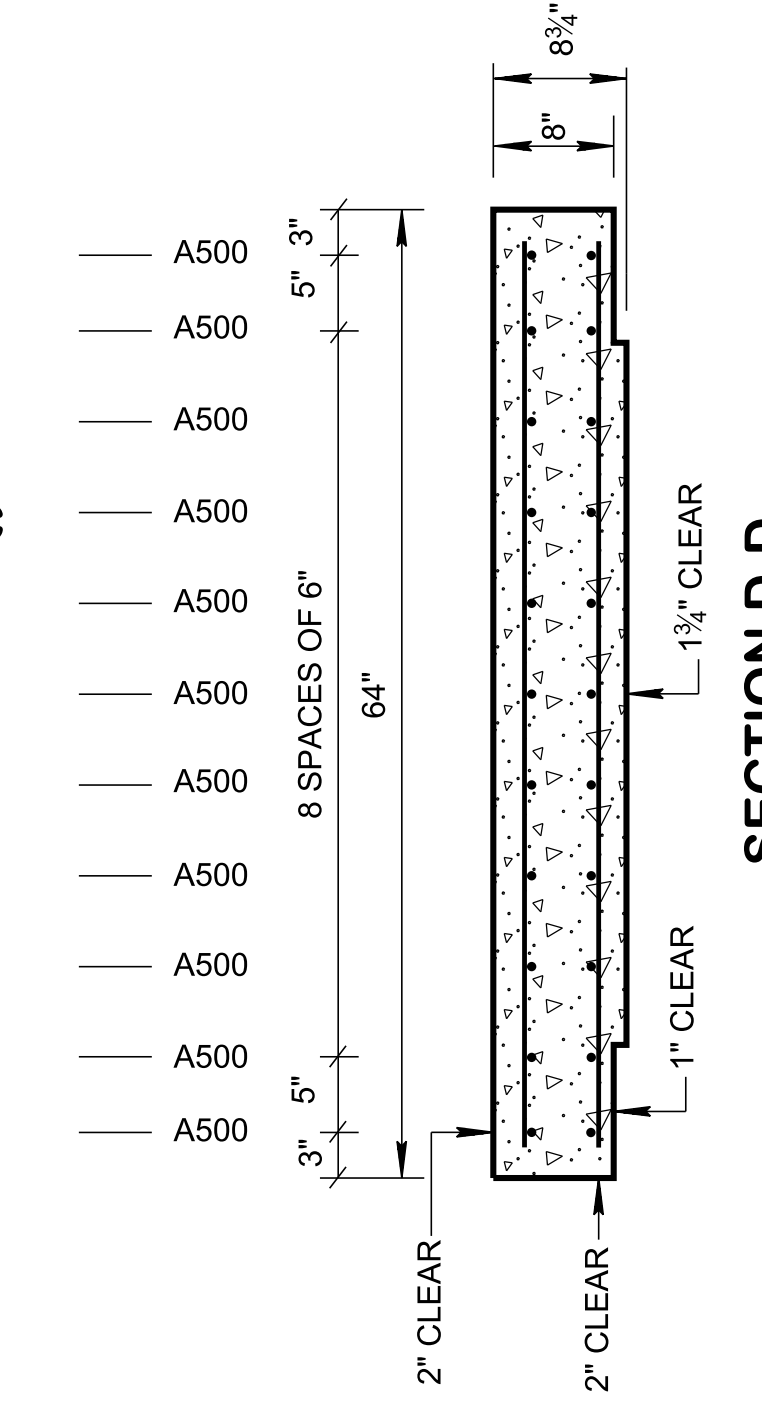

SECTION D-D

SPRING DRAIN BOX DIMENSIONS				FOR DESIGN USE ONLY SPRING DRAIN MINIMUM DESIGN DEPTH (FEET)
INSIDE DIAMETER (D) OF PIPE (INCHES)	PIPE WALL THICKNESS (INCHES)	DIAMETER OF CUT-OUT HOLES (INCHES)	SPRING DRAIN HEIGHT (INCHES)	
24	3	32	56	3.67

- 1 CUT-OUT HOLES BASED ON REINFORCED CONCRETE PIPE WITH WALL TYPE "B".
- 2 ALL FLEXIBLE PIPE MATERIALS REQUIRE GASKET. SEE STANDARD DRAWING D-PB-2.
- 3 CUT-OUT HOLES FOR PRECAST STRUCTURES TO BE FORMED IN ORDER TO OBTAIN A SMOOTH EDGED HOLE. SCORED OR ETCHED HOLES WITH REINFORCING STEEL LEFT UNCU T WILL NOT BE PERMITTED.

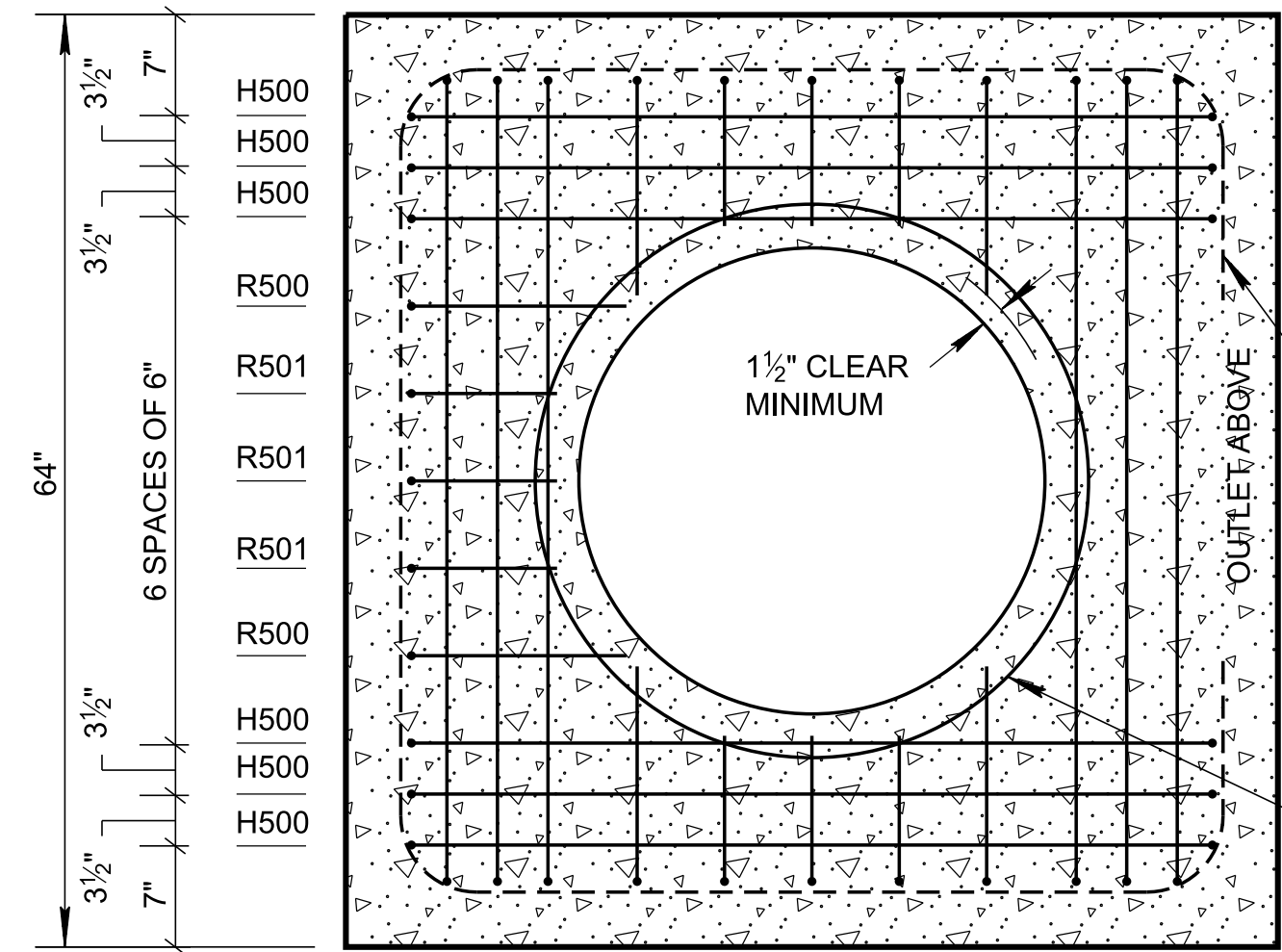

BOTTOM SLAB

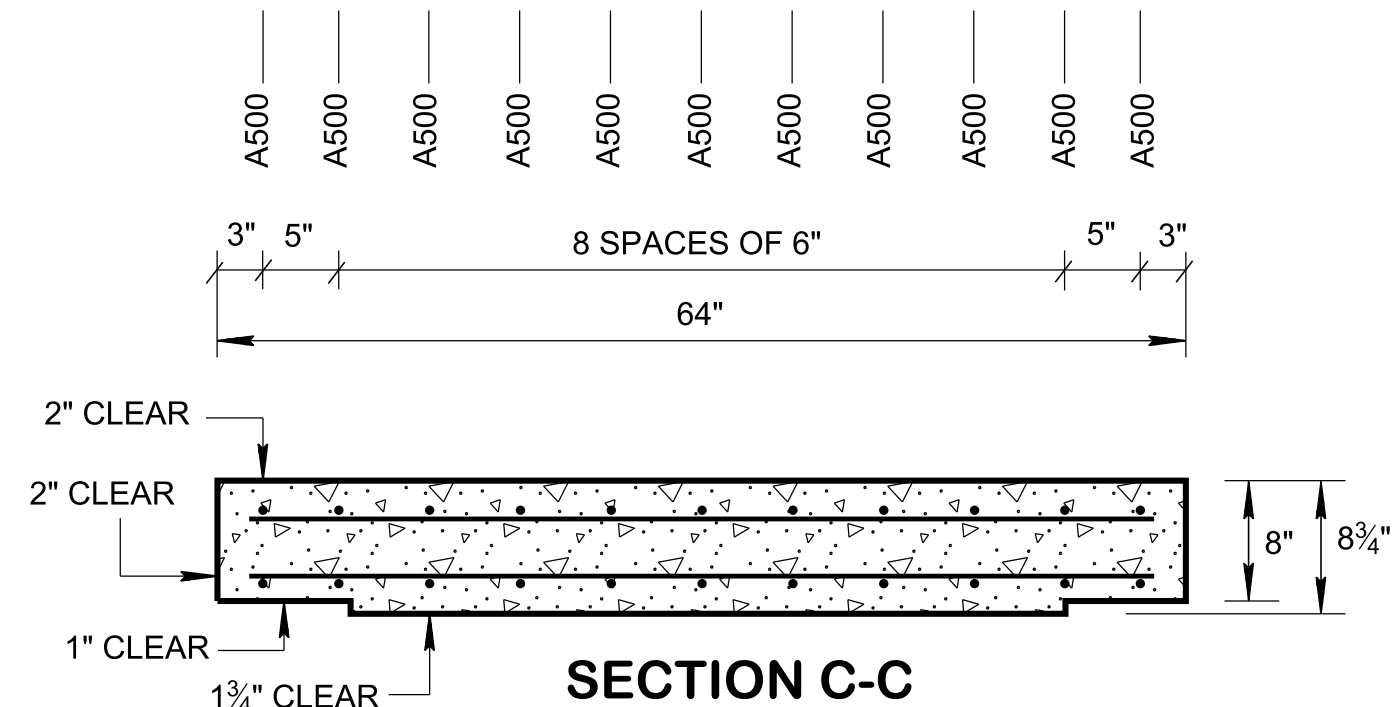

SECTION C-C

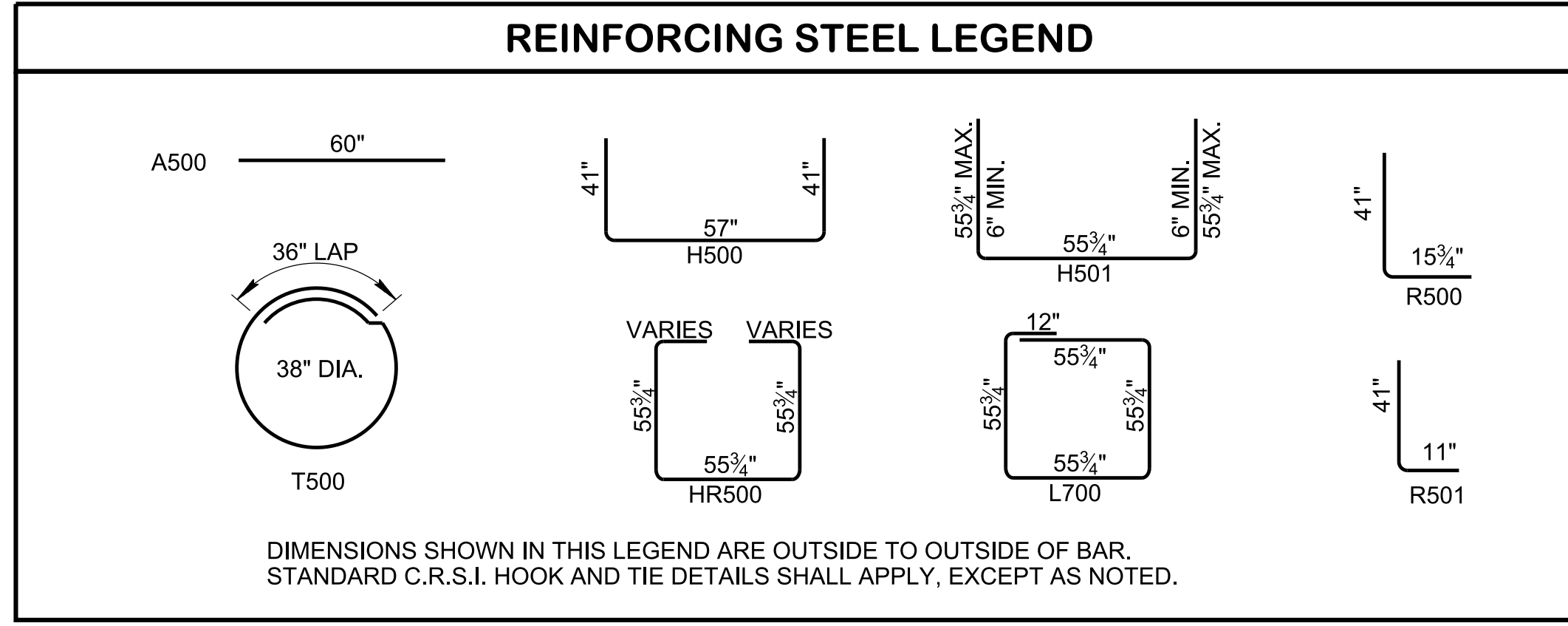

REINFORCING STEEL LEGEND

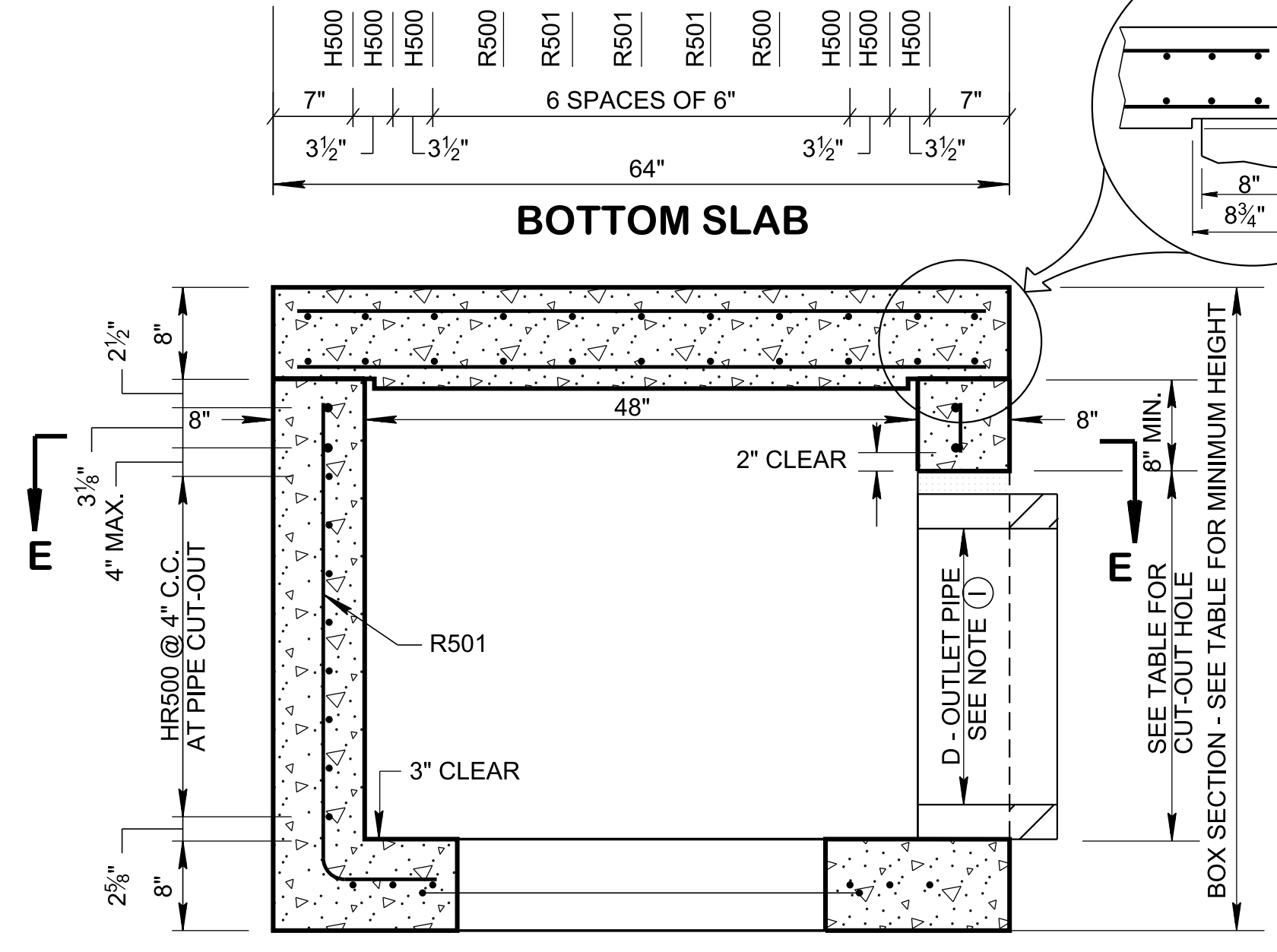

SIDE VIEW - SECTION A-A

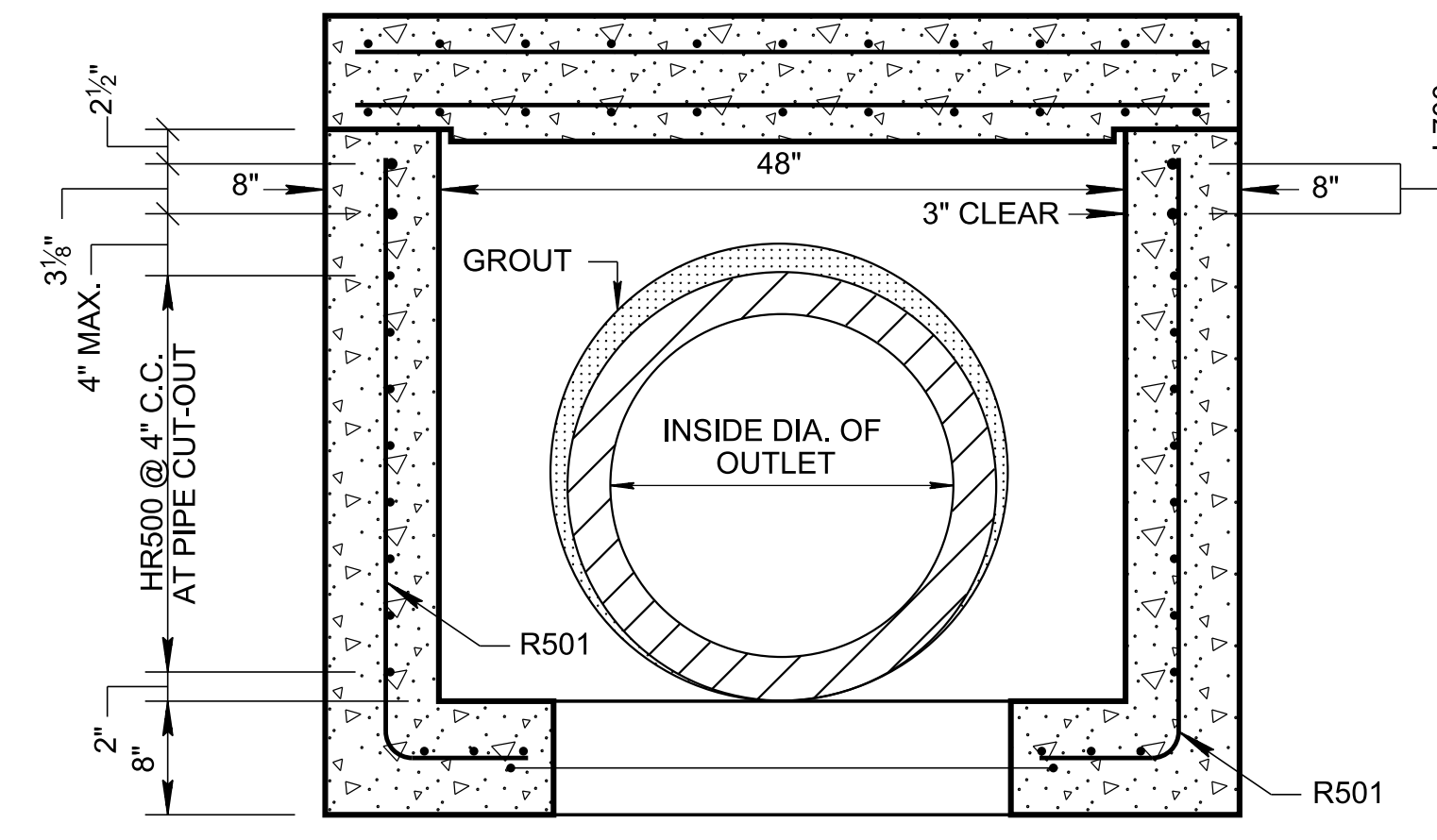
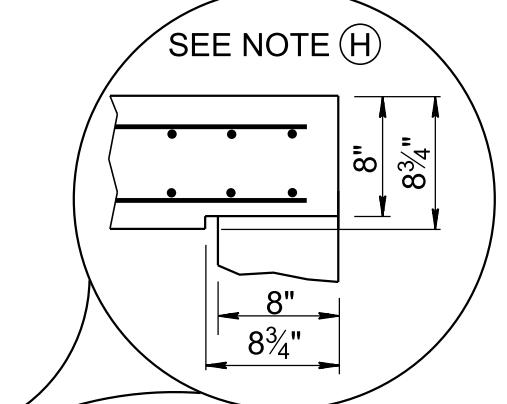

FRONT VIEW - SECTION B-B

- GENERAL NOTES**
- (A) DRAWING TO BE USED FOR ALL CAST-IN-PLACE NO. 2A CONCRETE SPRING DRAIN BOXES AND ALL PRECAST NO. 2A CONCRETE SPRING DRAIN BOXES. SEE STANDARD DRAWING D-CB-99 FOR ADDITIONAL CONSTRUCTION NOTES & DETAILS.
 - (B) EMBANKMENT OVER THIS STRUCTURE MAY BE PLACED AT A DEPTH UP TO 50 FEET. IF STRUCTURE IS LOCATED WITHIN THE CLEAR ZONE, A MINIMUM COVER OF 2 FEET IS REQUIRED.
 - (C) CAST-IN-PLACE CONCRETE SPRING DRAIN BOXES SHALL BE CONSTRUCTED IN ACCORDANCE WITH STANDARD SPECIFICATIONS. SECTION 611 AND/OR SPECIAL PROVISIONS UNLESS SUPERSEDED BY THIS DRAWING. THE CONTRACTOR MAY, WITH PERMISSION FROM THE ENGINEER, SUBSTITUTE PRECAST SPRING DRAIN BOXES FOR CAST-IN-PLACE SPRING DRAIN BOXES PROVIDED THAT ALL PRECAST ELEMENTS MEET ASTM C913 (CURRENT EDITION) UNLESS SUPERSEDED BY THIS DRAWING.
 - (D) THE FOLLOWING MATERIAL PROPERTIES ARE REQUIRED FOR BOTH CAST-IN-PLACE AND PRECAST STRUCTURES:
CONCRETE: $f'_c = 4,000$ POUNDS PER SQUARE INCH AT 28 DAYS
REINFORCING STEEL: ASTM A615, $F_y = 60,000$ POUNDS PER SQUARE INCH
ALL REINFORCING IS TO BE INSTALLED AS DETAILED ON THIS DRAWING.
 - (E) PRECAST SPRING DRAIN BOX UNITS WHICH ARE DAMAGED DURING SHIPMENT OR INSTALLATION WILL BE REJECTED. IT SHALL BE THE RESPONSIBILITY OF THE CONTRACTOR TO REPLACE DAMAGED SPRING DRAIN BOX UNITS AT THEIR OWN EXPENSE.
 - (F) APPROPRIATE SIZING AND LOCATION OF LIFTING DEVICES SHALL BE THE RESPONSIBILITY OF THE FABRICATOR.
 - (G) THE CONTRACTOR IS TO PATCH ALL LIFTING DEVICE HOLES WITH GROUT AND PLACE A MINIMUM OF ONE (1) INCH OF COVER OVER THE HARDWARE OF THESE DEVICES ON BOTH TOP AND BOTTOM SURFACES.
 - (H) ALTERNATIVE JOINT DETAILS MAY BE ACCEPTABLE. SEE STANDARD DRAWING D-CB-99 FOR ADDITIONAL DETAILS.
 - (I) SEE ROADWAY PLANS DRAINAGE TABULATION FOR PIPE OUTLET ELEVATIONS. IF NEEDED, INVERT ELEVATIONS MAY BE ADJUSTED AS DIRECTED BY THE ENGINEER IN ORDER TO ACCOMMODATE OUTLET PIPES.
 - (J) PAYMENT FOR SPRING DRAIN BOX WILL BE MADE UNDER ITEM NUMBER:
611-02.02, SPRING DRAIN BOX, TYPE 2A, EACH.

GENERAL NOTES

3/23/2020 11:32:55 AM C:\Users\jij\00547\Desktop\10-102.00 Catch Basins and Manholes IP\102.04 Spring Drain Boxes IP\102.04 Spring Drain Boxes IP\SDSDS2A-20200220.dgn