

SECTION A-A
N.T.S.

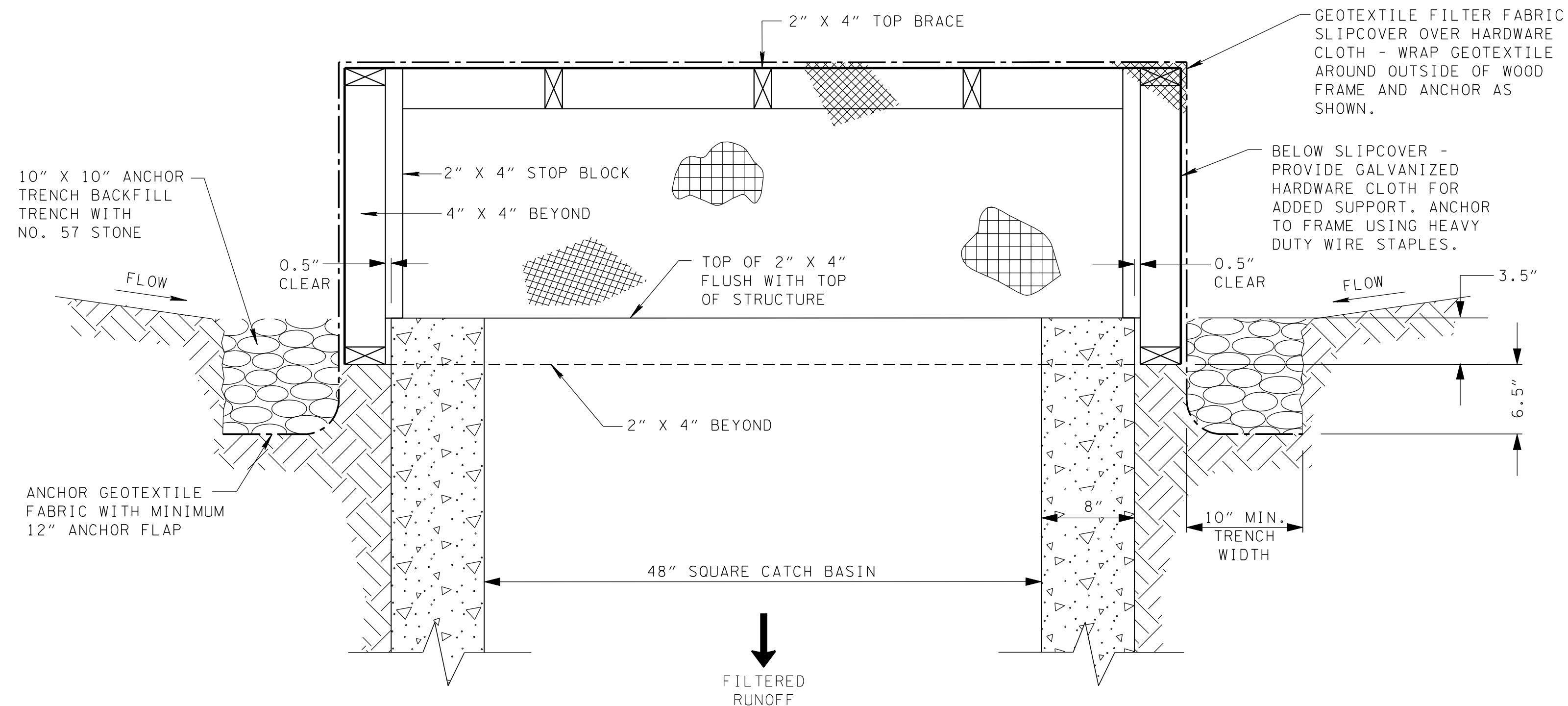

SECTION B-B
N.T.S.

EROSION CONTROL PLAN LEGEND:  CATCH BASIN FILTER ASSEMBLY (TYPE 2)

SLIPCOVER FILTER SPECIFICATIONS		
FABRIC TYPE : NON-WOVEN, NEEDLE-PUNCHED GEOTEXTILE		
FABRIC PROPERTY	ASTM TEST METHOD	MINIMUM AVERAGE ROLL VALUES (MARVS)
GRAB TENSILE STRENGTH	ASTM D4632	≥180 LBS
GRAB ELONGATION	ASTM D4632	≥50%
MULLEN BURST	ASTM D3786	≥330 PSI
PUNCTURE STRENGTH	ASTM D4833	≥105 LBS
TRAPEZOIDAL TEAR	ASTM D4533	≥75 LBS
APPARENT OPENING SIZE (AOS)	ASTM D4751	FINER THAN OR EQUAL TO #80 U.S. STANDARD SIEVE
PERMEABILITY	ASTM D4491	≥0.12 INCHES/SEC
PERMITTIVITY	ASTM D4491	≥1.5 SEC ⁻¹
WATER FLUX	ASTM D4491	≥110 GAL/MIN/FT ²
UV RESISTANCE	ASTM D4355	≥70% AT 500 HOURS
WEIGHT	ASTM D3776	MINIMUM 6 OZ/YD ²
HARDWARE CLOTH SPECIFICATIONS		
STANDARD SPECIFICATION	ASTM A740	
OPENING SIZE	0.5 INCH X 0.5 INCH	
WIRE SIZE	19 GAUGE	
WIRE DIAMETER	0.041 INCHES	
WEIGHT	± 0.2 LBS/SF	
GRADE	LOW CARBON STEEL (C1008)	
TYPE	WELDED HOT GALVANIZED STEEL WIRE FABRIC	

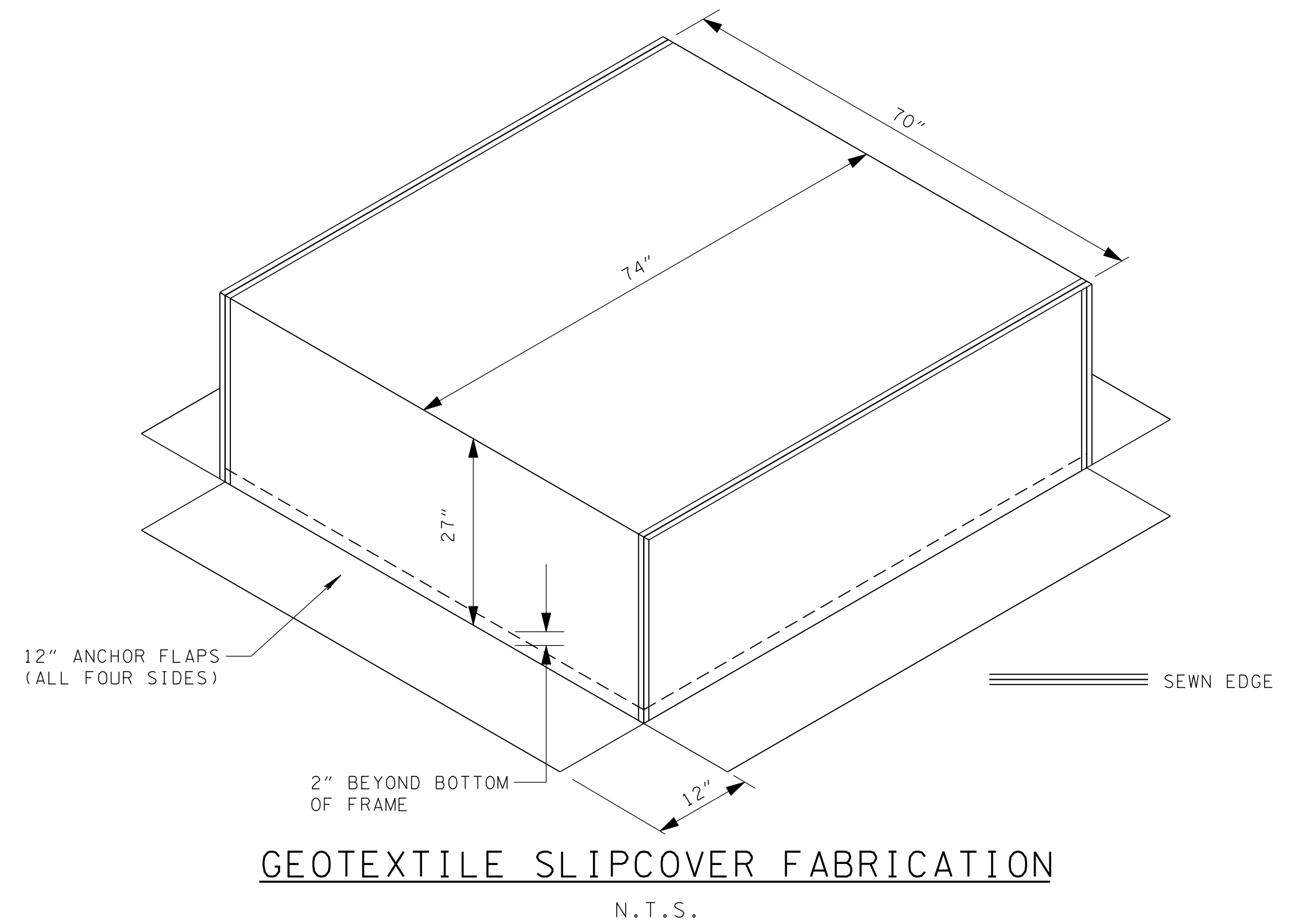

GEOTEXTILE SLIPCOVER FABRICATION
N.T.S.

FABRICATION SPECIFICATIONS:

1. GEOTEXTILE SLIPCOVER FABRIC SHALL HAVE HEAT-CUT FUSING FABRIC EDGES FOR STRENGTH.
2. ALL SEAMS SHALL BE SEWN WITH TWO INDEPENDENT ROWS OF LOCK-TYPE STITCHING, USING UV-BONDED POLYESTER THREAD (MINIMUM OF 138 POUNDS) WITH MINIMUM OF SIX STITCHES PER INCH.
3. THE INSIDE ROW OF STITCHING SHALL BE A MINIMUM OF 0.5" FROM HEAT-CUT FABRIC EDGES.

STATE OF TENNESSEE
DEPARTMENT OF TRANSPORTATION

CATCH BASIN
FILTER ASSEMBLY
(TYPE 2)
SLIPCOVER DETAILS

4-15-04 EC-STR-42A