

FENCING TERMINALS AT BRIDGE ABUTMENTS

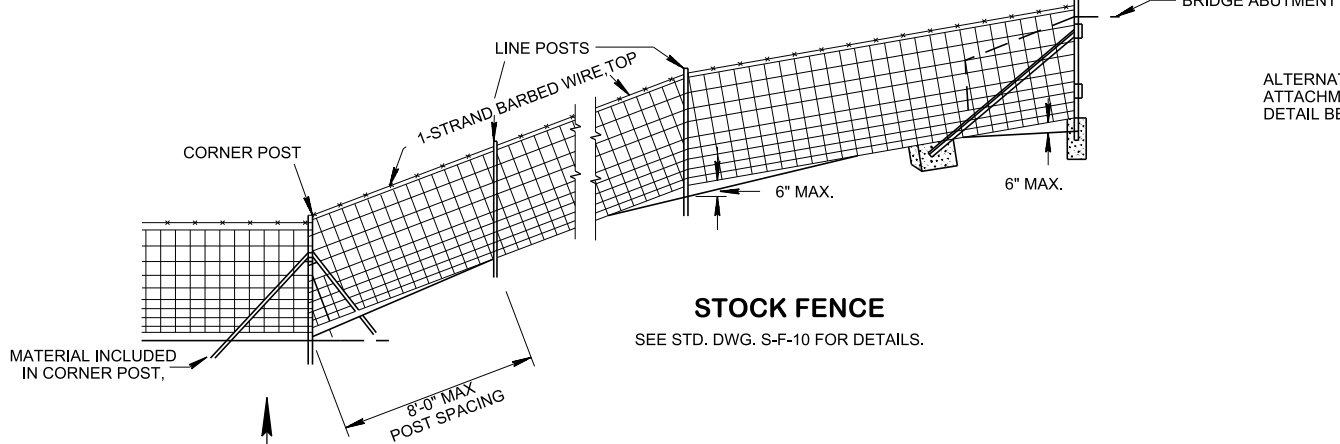

STOCK FENCE
SEE STD. DWG. S-F-10 FOR DETAILS.

NOTE: THESE INSTALLATION SCHEMES ARE TYPICAL AND ARE NOT TO BE CONSTRUED AS REPRESENTATIVE OF ALL CONDITIONS WHICH WILL BE ENCOUNTERED. CONSTRUCTION MAY BE VARIED AS REQUIRED TO MEET FIELD CONDITIONS AND/OR AS DIRECTED BY ENGINEER.

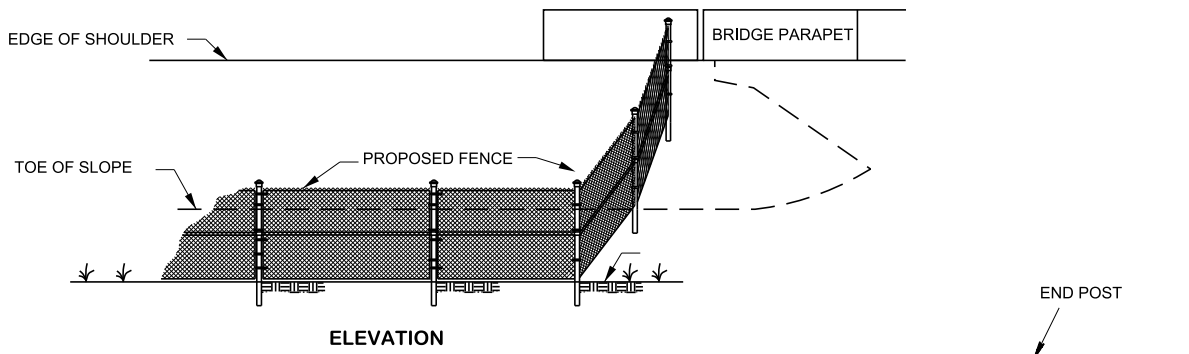
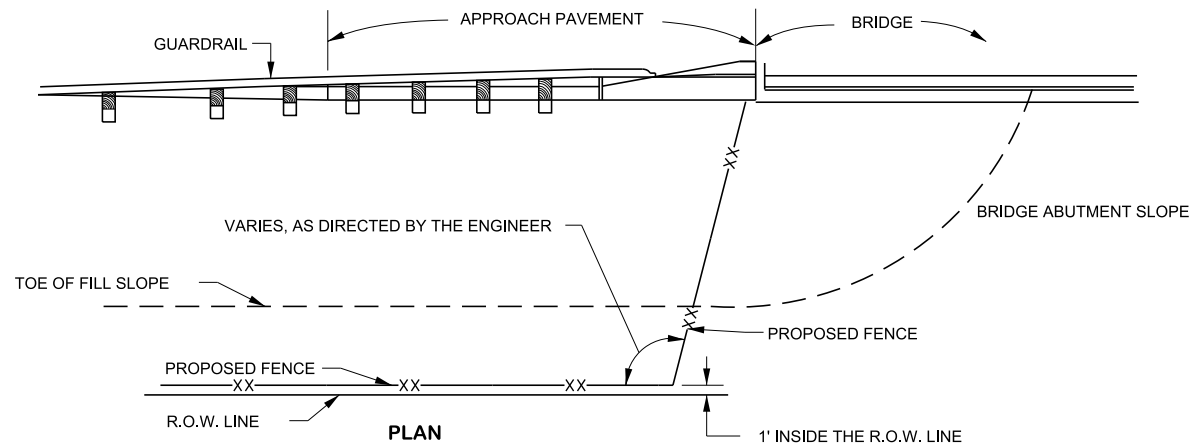
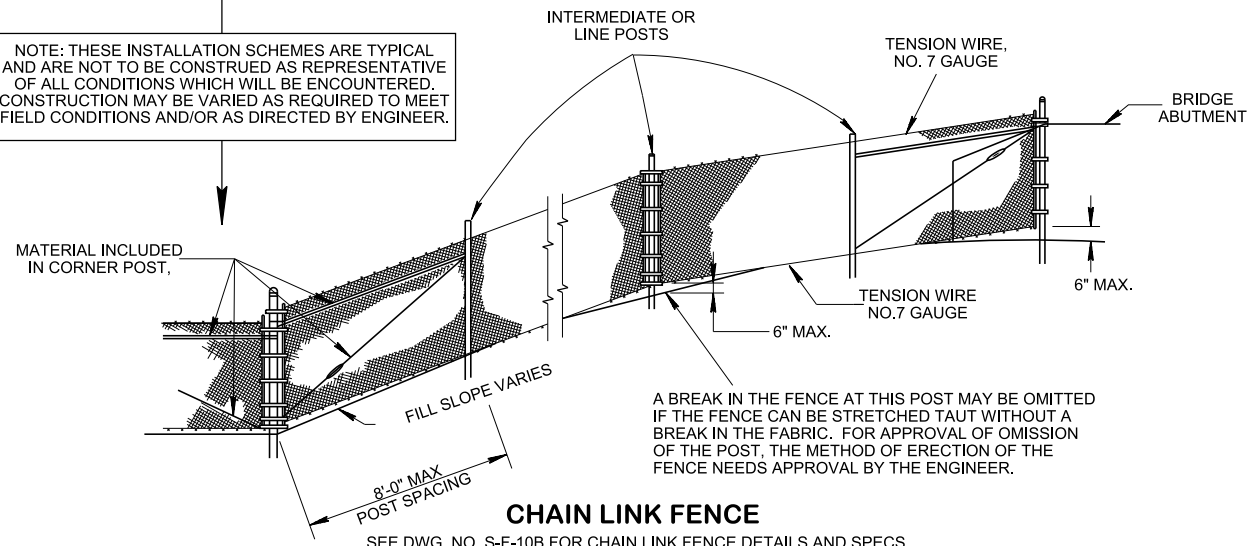

CHAIN LINK FENCE
SEE DWG. NO. S-F-10B FOR CHAIN LINK FENCE DETAILS AND SPECS.

FENCE UP AND OVER DRAINAGE STRUCTURES WITHOUT WINGWALLS

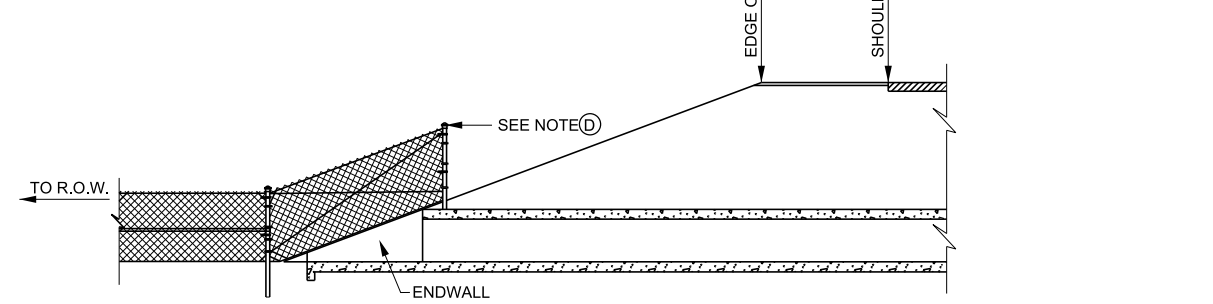
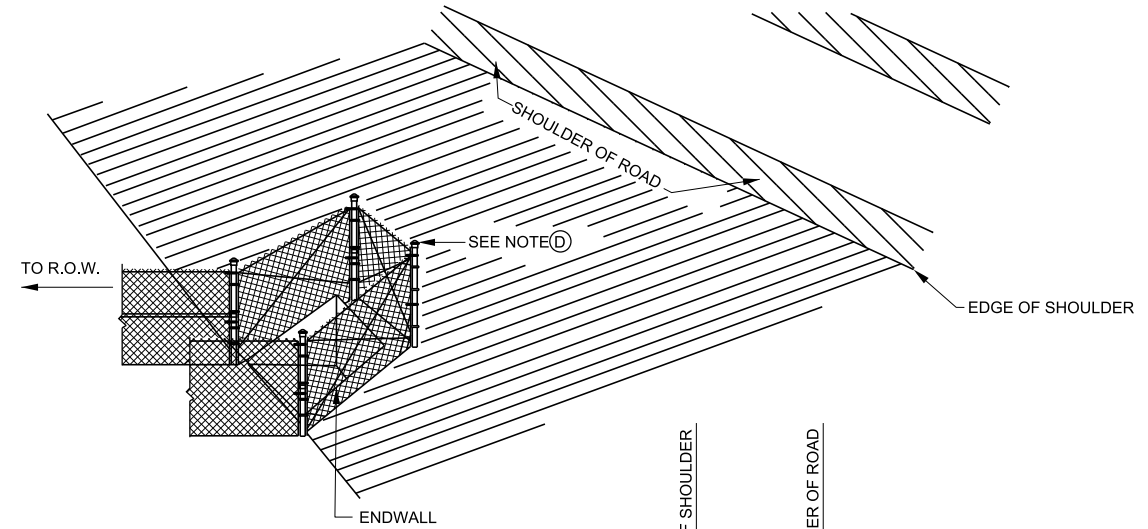

DRAINAGE STRUCTURES WITH WINGWALLS

ALTERNATIVE POST ATTACHMENT SEE DETAIL BELOW

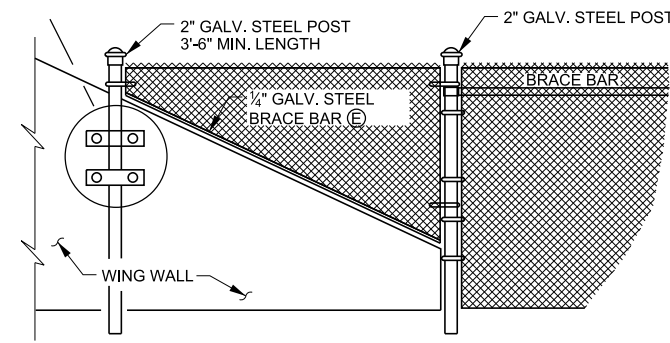

1. FOR USE WHEN DRAINAGE STRUCTURE HEIGHT IS 5'-8" OR GREATER AND WHEN IT IS NOT FEASIBLE TO GO UP AND OVER THE DRAINAGE STRUCTURE AS SHOWN ON THIS SHEET.
2. FENCING TERMINALS AT RETAINING WALL DETAIL ON S-F-10D MAY BE USED AS AN ALTERNATE.

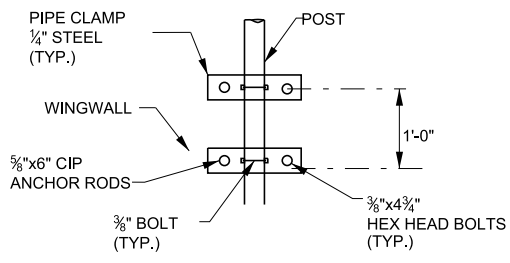
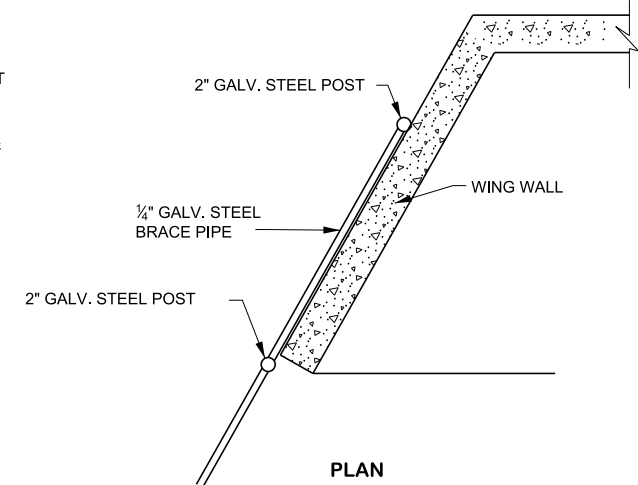

PIPE CLAMP CONNECTION DETAIL

GENERAL NOTES

(A) RIGHT-OF-WAY FENCE SHALL CONFORM TO NOTES AND DETAILS SPECIFIED ON STANDARD DRAWING NO. S-F-10B FOR URBAN AREAS AND S-F-10 AND S-F-10A FOR RURAL AREAS.

(B) SEE S-FG-20 FOR WATER CROSSING DETAILS.

(C) EXPLORE EVERY OPTION NOT TO DISTURB EXISTING VEGETATION DURING THE INSTALLATION OF THE FENCE.

(D) THE ELEVATION OF THE FENCE POST TOP SHALL BE LOWER THAN THE ROADWAY SHOULDER AND THE NEAREST PORTION OF THE FENCE SHALL BE OUTSIDE THE CLEAR ZONE.

(E) FOR BRACE BAR DETAILS SEE STD. DWG. S-F-10B.

- REV. 5-14-10: REMOVED ITEM NUMBERS.
- REV. 11-15-17: CHANGED FONT. CORRECTED PROPOSED FENCE LINE TYPE IN THE PLAN VIEW. ADDED GENERAL NOTE (C). CHANGED DISTANCE BETWEEN R.O.W. LINE AND R.O.W. FENCE FROM 6" TO 1' TO MATCH STANDARD SPECIFICATIONS.
- REV. 06-28-2019: REDREW SHEET.

■ MINOR REVISION - FHWA APPROVAL NOT REQUIRED

STATE OF TENNESSEE
STANDARD DRAWING
DEPARTMENT OF TRANSPORTATION

RIGHT-OF-WAY FENCE AT BRIDGE AND BOX CULVERTS

12/5/2019 2:50:14 PM P:\StandDraw\DESIGN STANDARDS\Standards Library\Standard Roadway Drawings - CURRENT\In Progress\10-104.00 Roadway, Pavement Appurtenances and Fence IP1104.05 Fence & Right of Way

NOT TO SCALE