



Designation: F3561 – 22

# Standard Test Method for Forced-Entry-Resistance of Fenestration Systems After Simulated Active Shooter Attack<sup>1</sup>

This standard is issued under the fixed designation F3561; the number immediately following the designation indicates the year of original adoption or, in the case of revision, the year of last revision. A number in parentheses indicates the year of last reappraisal. A superscript epsilon ( $\epsilon$ ) indicates an editorial change since the last revision or reappraisal.

## 1. Scope

1.1 This test method sets forth the requirements and testing procedures to test forced-entry-resistant building components, construction components, and specialty security equipment. This test method is intended primarily for manufacturers to test and rate their windows, doors, modular panels, glazings, and similar products to ensure that all manufactured products meet the necessary requirements for forced-entry protection after sustaining an active shooter assault.

1.2 This test method is currently designed to simulate an active shooter weakening the system with repetitive shots followed by mechanically driven impact to simulate forced entry.

1.3 This test method is not to be used for ballistic resistant glazing rating. Test projectiles are permitted to perforate the entire specimen. The test projectile firings are intended to simulate actions taken by an assailant to aid in the ability to gain entry to a facility.

1.4 This is a laboratory test to be performed on full systems and therefore not applicable for field testing.

1.5 All tests are executed on the exterior surface of the fenestration.

1.6 Systems are required to be tested as complete units in a test frame or fielded conditions. Muller systems must be tested in the muller condition. Test results only apply to the component or system as tested. Once a system is tested and deemed to satisfy the requirements of this test method, no design change can be made without a retest except those that qualify under **Annex A1** Substitution Criteria.

1.7 Components (such as glazing, door leaves, etc.) may be tested in accordance with **Appendix X1**, receiving a capability statement for the component, but not a system rating per this standard.

1.8 Window and door systems shall be rated to at least a minimum level of Test Methods **F476**, **F588**, or **F842**, or

combinations thereof, as appropriate prior to commencing this test evaluation. This test does not dual certify to the above mentioned standards.

1.9 The values stated in this standard are SI units with the exception of the nominal descriptors for tools.

1.10 *This standard does not purport to address all of the safety concerns, if any, associated with its use. It is the responsibility of the user of this standard to establish appropriate safety, health, and environmental practices and determine the applicability of regulatory limitations prior to use.*

1.11 *This international standard was developed in accordance with internationally recognized principles on standardization established in the Decision on Principles for the Development of International Standards, Guides and Recommendations issued by the World Trade Organization Technical Barriers to Trade (TBT) Committee.*

## 2. Referenced Documents

- 2.1 *ASTM Standards:*<sup>2</sup>
  - [A36/A36M Specification for Carbon Structural Steel](#)
  - [A574 Specification for Alloy Steel Socket-Head Cap Screws](#)
  - [C719 Test Method for Adhesion and Cohesion of Elastomeric Joint Sealants Under Cyclic Movement \(Hockman Cycle\)](#)
  - [C1036 Specification for Flat Glass](#)
  - [C1048 Specification for Heat-Strengthened and Fully Tempered Flat Glass](#)
  - [C1135 Test Method for Determining Tensile Adhesion Properties of Structural Sealants](#)
  - [C1172 Specification for Laminated Architectural Flat Glass](#)
  - [D1415 Test Method for Rubber Property—International Hardness](#)
  - [D3575 Test Methods for Flexible Cellular Materials Made from Olefin Polymers](#)
  - [E631 Terminology of Building Constructions](#)
  - [E3062/E3062M Specification for Indoor Ballistic Test Ranges for Small Arms and Fragmentation Testing of](#)

<sup>1</sup> This test method is under the jurisdiction of ASTM Committee F12 on Security Systems and Equipment and is the direct responsibility of Subcommittee F12.10 on Systems Products and Services.

Current edition approved Aug. 1, 2022. Published August 2022. DOI: 10.1520/F3561-22.

<sup>2</sup> For referenced ASTM standards, visit the ASTM website, [www.astm.org](http://www.astm.org), or contact ASTM Customer Service at [service@astm.org](mailto:service@astm.org). For *Annual Book of ASTM Standards* volume information, refer to the standard's Document Summary page on the ASTM website.

### Ballistic-resistant Items

**F476** Test Methods for Security of Swinging Door Assemblies

**F588** Test Methods for Measuring the Forced Entry Resistance of Window Assemblies, Excluding Glazing Impact

**F842** Test Methods for Measuring the Forced Entry Resistance of Sliding Door Assemblies, Excluding Glazing Impact

**F1915** Test Methods for Glazing for Detention Facilities

#### 2.2 Other Standards:

**ISO/IEC 17025:2005** General Requirements for the Competence of Testing and Calibration Laboratories<sup>3</sup>

specimen shall consist of the entire fenestration assembly and contain all devices used to resist forced entry; all parts of the test specimen shall be full size, as specified for actual use, using the identical materials, details, and methods of construction.

3.1.13 *shop assembly drawing, n*—a drawing which shows how a system is assembled including the locations, dimensions, and arrangements of all assembly elements such as bolts, glazing stops, and glazing spacers.

3.1.14 *system, n*—the assembly of structural elements and devices which comprise the forced-entry-resistant barrier.

3.1.15 *test director, n*—the individual identified by the independent testing laboratory as being responsible to complete the specified tests as required and to document the results, in accordance with this test method.

3.1.16 *test facility, n*—laboratory or other area where forced-entry testing is conducted.

3.1.17 *test fixture, n*—the structural assembly which holds the test specimen.

3.1.18 *test levels, n*—the increments to which systems are tested.

3.1.19 *test plane, n*—a plane parallel and contiguous to the face of the attack side of the test sample.

3.1.20 *test projectiles, n*—projectiles or ammunition that is used to weaken the test specimen.

3.1.21 *test shape, n*—a non-compressible sphere measuring 152 mm (6 in.) in diameter.

3.1.22 *test tools, n*—the devices used by the test team during the assault tests.

3.1.23 *testing report, n*—a report provided by the test facility that includes configuration documentation, any applicable abnormality, forced-entry testing data and photographs, a certification of testing, a narrative summary of testing, time-stamped drawings that have been validated to match the test specimen, and all video recording(s) of testing.

3.1.24 *view window, n*—a window system which permits visual contact through an otherwise opaque host assembly.

3.1.25 *window frame, n*—the opaque portion of a transparent assembly into which the transparent element is mounted.

3.1.26 *yaw, n*—the angular deviation between the test projectile's axis of symmetry and its line of travel.

#### 3.2 Abbreviations:

3.2.1 AN—annealed

3.2.2 C1—center 1

3.2.3 C2—center 2

3.2.4 CS—chemically strengthened

3.2.5 E—East

3.2.6 FMJ—Full Metal Jacket bullet

3.2.7 FT—fully tempered

3.2.8 ft/s—feet per second

3.2.9 ft-lbf—foot pound-force

3.2.10 H—drop height

### 3. Terminology

#### 3.1 Definitions of Terms Specific to This Standard:

3.1.1 *component, n*—integral part of a forced entry test specimen such as: panels, frame, glazing, glazing bite, flanges, hinges, locks, jamb/wall, jamb/strike mullions, and mounting devices of different shape, size, and material.

3.1.2 *door, double, n*—two-door assembly with an opening wider than as a single door with a common latch and lock edge; may or may not include a removable mullion; openings may be asymmetrical with regard to the size of openings.

3.1.3 *door panel, n*—the swinging or sliding barrier by which an entry is closed and opened, not including framing, operating, or latching mechanisms.

3.1.4 *failure criteria, n*—any failure of the manufacturer's recommended mounting hardware or penetration of any portion of the system sufficient to permit passage of the test shape.

3.1.5 *fenestration, n*—any glazed panel, window, door, curtain wall, or skylight unit on the exterior of a building.

3.1.6 *glazing weakening, v*—intentional structural deterioration of a glazing or glazing infill.

3.1.7 *impact assault, n*—test of forced entry attack using an impactor on one dissimilar component in an attempt to create an opening and permit passage of the test shape.

3.1.8 *impactor, n*—45 kg striking mechanism capable of being deployed in a pendulum motion.

3.1.9 *independent test facility, n*—testing laboratory accredited to perform the referenced testing procedures by a nationally recognized accrediting agency in accordance with ISO/IEC 17025.

3.1.10 *mulled, n*—the physical connection together of two parts of the same system; the two systems may be anchored directly to each other or have a mullion between them.

3.1.11 *mullion, n*—a component used to divide two parts of the same system and it can be vertical or horizontal, movable or fixed; for purposes of this test method, a mullion does not include steel or concrete structural members (including seismic joints) which are present in the building.

3.1.12 *ready-to-install, n*—fabricated, with an appropriate final finish such as galvanizing, paint, or anodizing; the test

<sup>3</sup> Available from International Organization for Standardization (ISO), ISO Central Secretariat, Chemin de Blandonnet 8, CP 401, 1214 Vernier, Geneva, Switzerland, <https://www.iso.org>.

- 3.2.11 HS—heat-strengthened
- 3.2.12 in.—inch(es)
- 3.2.13 IRHD—international rubber hardness degree
- 3.2.14 J—joules
- 3.2.15 kg—kilogram
- 3.2.16 L—horizontal swing distance
- 3.2.17 lb—pound
- 3.2.18 m/s—meters per second
- 3.2.19 mm—millimeter
- 3.2.20 MSG—manufacturers standard grade
- 3.2.21 n—noun
- 3.2.22 N—North
- 3.2.23 N—Newtons
- 3.2.24 NE—North East
- 3.2.25 NW—North West
- 3.2.26 oz—ounce
- 3.2.27 R—radius of swing
- 3.2.28 S—South
- 3.2.29 SE—South East
- 3.2.30 SW—South West
- 3.2.31 v—verb
- 3.2.32 W—West

**4. Summary of Test Method**

4.1 This test method establishes incremented levels of forced-entry protection via evaluation of a two-stage attack of a single or mulled system by using a device for weakening of components prior to forced entry impact of the fenestration system.

**5. Significance and Use**

5.1 The test requirements specified herein have been established for use in evaluating the forced-entry resistance characteristics of assemblies to be used in commercial, residential, schools, government, and other institutional installations where the risk of a single person active shooter attack is present.

5.2 The procedures of this test method are intended to evaluate the ability to create an opening of sufficient size to permit passage of a test shape through it.

5.3 The procedure presented herein is based on post-event examination and are not intended to be used to establish or confirm the absolute prevention of forced entries.

**6. Apparatus**

6.1 Apparatus to conduct these tests include ballistic firing mechanism or means to simulate ballistic type weakening, test fixture, impactor, measurement device, test shape, and force meter.

6.2 *Test Fixture*—The test fixture shall be sized to accommodate the test specimen and in accordance with design of Figure 1 in Test Methods F1915, or as specified by the authority having jurisdiction provided it does not enhance or degrade the specimen.

6.3 *Velocity Measurement System*—The velocity measurement system shall be capable of providing projectile velocities with at least a  $1 \times 10^{-6}$  sec sampling resolution and an accuracy of at least  $\pm 1.5$  m/s ( $\pm 5$  ft/s).

6.4 *Support Fixture and Frame*—The test specimen shall be mounted in the frame along the full length of all edges or as specified by the manufacturer’s installation instructions.

6.4.1 The frame shall have a clamping plate to hold the test specimen in position and means for producing uniform clamping of the specimen.

6.4.2 All edges of the test specimen shall be uniformly clamped with a clamping pressure sufficiently large that the edges remain in position during the test. The test specimen in the frame shall be placed normal to the direction of attack with an accuracy of  $\pm 0.02$  rad ( $1^\circ$ (degree)) in any orientation. Test specimen shall be oriented to strike face in accordance with manufacturer’s documentation. Manufacturer shall clearly mark the strike face on each specimen. The support and retention system shall be reported.

6.4.3 The test fixture shall simulate installation in a permanent steel or concrete structure which neither enhances nor degrades the forced-entry protection of the system.

6.5 *Glass Weakening Device*—The glass weakening device shall be capable of firing 10 test projectiles meeting the requirements of Table 1.

6.5.1 Test projectiles shall be fired using:

6.5.1.1 *AR-15 5.56 Rifle*, capable of discharging projectiles in accordance with 6.5.

6.5.1.2 *Ballistic Firing Mechanism*, capable of discharging projectiles in accordance with 6.5.

6.6 *Forced Entry Impactor System:*

6.6.1 *Impactor:*

6.6.1.1 The forced entry impactor shall be a pendulum system with a cylindrical weight capable of delivering horizontal impacts of 542 J (400 ft-lbf).

6.6.1.2 The diagram of the impactor is shown in Fig. 1. It is a steel cylinder 152 mm  $\pm$  6 mm (6 in.  $\pm$  0.25 in.) in diameter,

**TABLE 1 Test Projectiles**

Ammunition Description	Ammunition Identity Classification (AIC)	Bullet Weight (grain)	Velocity (Meters (ft/s)) $\pm 10$ m/s ( $\pm 33$ ft/s)
5.56 NATO, Copper Jacket Lead Core, FMJ	M193	55	1027 m/s (3370 ft/s)

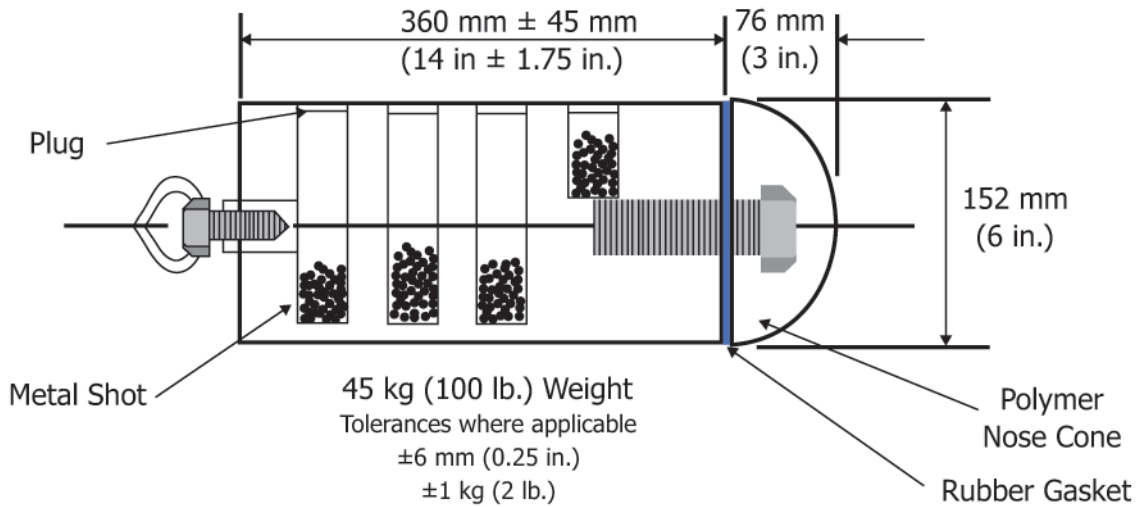

FIG. 1 Impactor Details

360 mm ± 45 mm (14 in. ± 1.75 in.) long, with a hemispherical impact nose 152 mm ± 6 mm (6 in. ± 0.25 in.) in diameter and maximum 76 mm (3 in.) deep. The impactor including eye bolts weighs 45 kg ± 1 kg (100 lb ± 2 lb).

6.6.1.3 The shot is used to obtain the proper weight of the impactor as needed. The shot should be constrained in holders attached to the impactor to avoid excessive movement during

testing. The shot is to be positioned evenly to balance the weight of the impactor front to back in the suspension system.

6.6.1.4 The impact nose used in this equipment is made from cast epoxy polyamide resin; however, any durable impact-resistant material is satisfactory.

6.6.1.5 The durometer of the impact nose shall be Shore D hardness 80 ± 10.

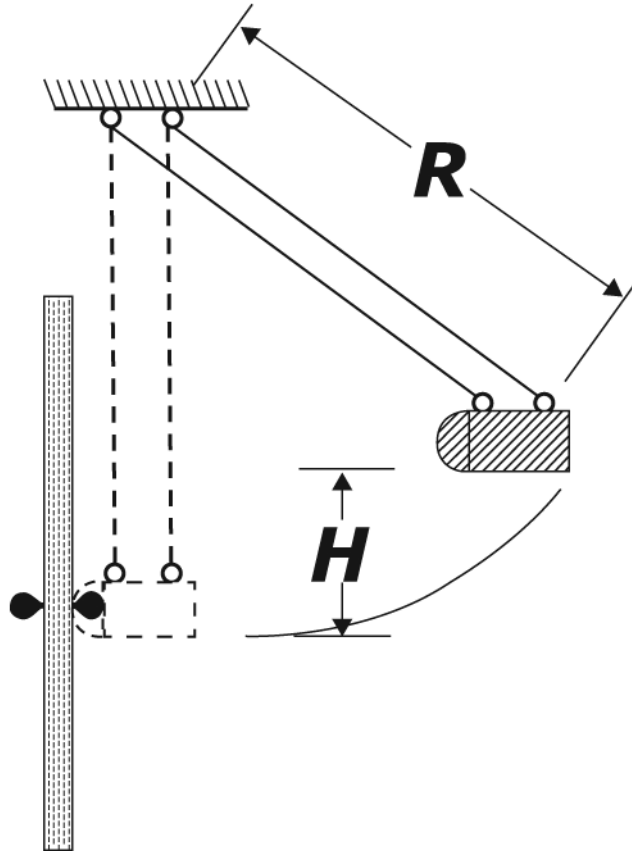

FIG. 2 Impactor Swing and Measurement Schematic

6.7 Suspension System:

6.7.1 The suspension system for the impactor consists of four flexible steel cables providing a swing radius of 1710 mm ± 52 mm (67 in. ± 2 in.), as shown in Fig. 2.

NOTE 1—Fig. 2 is for example only. Suspension system should be capable of allowing adequate, smooth, and consistent delivery of designated force.

6.7.2 Fig. 3 includes a diagram of the pendulum system when elevated and at rest, and the measurements required to calculate the impact energy of the system.

6.7.3 These cables are adjusted to equal length with turn-buckles such that the impactor swings in a straight, true arc and are attached to a steel frame that can be adjusted to be level (Fig. 2).

6.7.4 Table 2 presents the potential energy of a pendulum system with a 45 kg ± 1 kg (100 lb ± 2 lb) weight as a function of various elevations of the weight. The suspension cables are not included in the weight and energy calculations of the impactor.

6.8 Test Shape—The test shape used to determine if passage has been achieved is defined in 3.1.21.

7. Hazards

7.1 This test method involves potentially hazardous situations. Proper precautions shall be taken by the test facility to protect workers, observers, and the community. The test location shall be secured to prevent unauthorized access during testing. All testing personnel and observers shall be kept out of the path of the projectile and behind a hardened barrier to minimize ricochet or fragmentation hazards during testing. The main backstop shall be designed to safely contain the projectile

TABLE 2 Potential Energy of Impactor and Drop Height

Level	Potential Energy, J		Height of Drop (H)	
	J	(ft*lb)	mm	(ft)
1	68	50	152	0.50
2	136	100	305	1.00
3	203	150	457	1.50
4	271	200	610	2.00
5	339	250	762	2.50
6	407	300	914	3.00
7	475	350	1067	3.50
8	542	400	1219	4.00

and prevent damage to life or property down range in the projectile’s line of flight.

7.2 The testing lab shall be properly designed to minimize health effects to workers resulting from lead dust exposure. Proper handling, storage, and disposal of lead contaminated materials shall be consistent with all local and federal laws and requirements found in the Resource Conservation & Recovery Act of 1976.

8. Test Specimens

8.1 Systems submitted for testing shall be full-size systems complete with all required anchor bolt system hardware and representative of production systems.

8.2 Systems that move or operate (for example, doors, hatches, operable windows) shall, at minimum, include all devices required for operation.

8.3 The test specimen shall be ready-to-install.

8.4 Three (3) test specimens of identical construction shall constitute a sample set for testing.

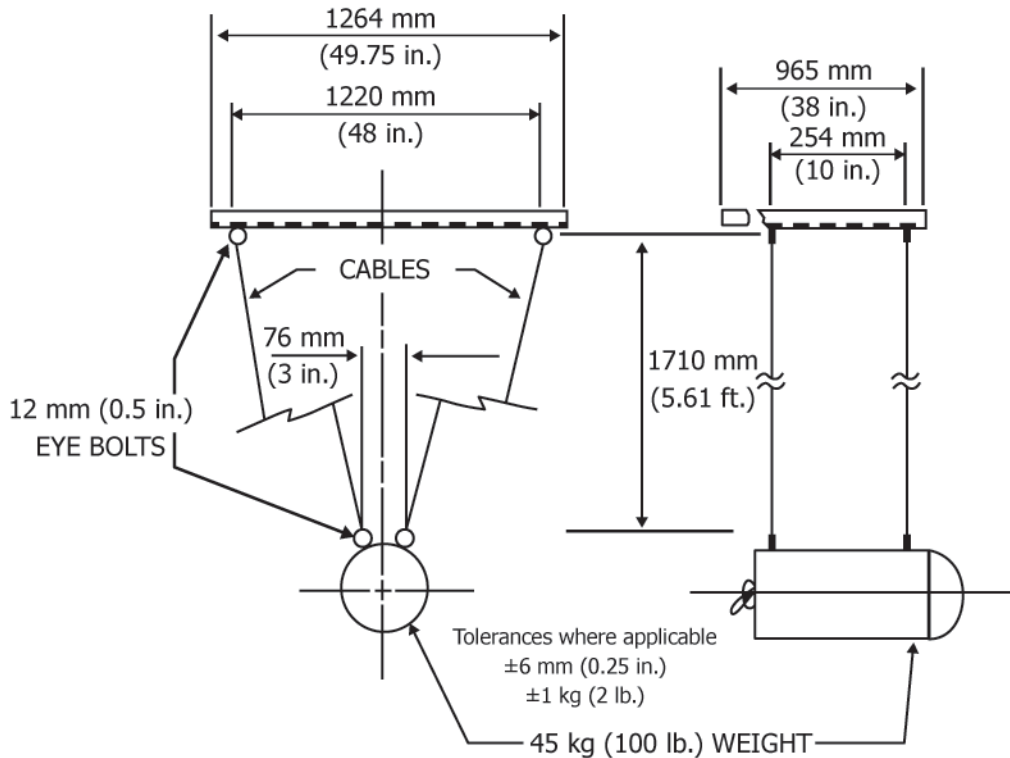

FIG. 3 Detail of Impactor Cable System



## 9. Preparation of Apparatus

### 9.1 Preparation:

9.1.1 Review the test specimen configuration and test sample documents supplied in accordance with 9.1.2 to ensure the proper sample is being tested.

9.1.2 Ensure testing apparatus is in good condition and configured per 6.2.

9.1.3 Install test specimen in support fixture per 6.4.

9.1.4 *Support Fixture and Frame*—The test specimen shall be mounted in the frame along the full length of all edges.

9.1.4.1 The frame shall have a clamping plate to hold the test specimen in position and means for producing uniform clamping of the test specimen.

9.1.4.2 All edges of the test specimen shall be uniformly clamped with a clamping pressure sufficiently large that the edges remain in position during the test.

9.1.5 Forced-entry test specimens shall be mounted in accordance with all the requirements of this section.

9.1.5.1 The mounting of the test specimen must give no leverage advantages and shall not influence the performance of the test specimen over the expected mounting conditions in the field.

9.1.5.2 The test specimen shall be mounted in accordance with the manufacturer's instructions with particular attention paid to the threat and protected side orientation during mounting.

(1) If the test specimen cannot be mounted according to the installation instructions submitted by manufacturer, the test shall not be conducted.

9.1.5.3 If the tested product type is typically installed in an opening larger than the tested product size (for example, in a "rough opening"), the test specimen shall be mounted in a rough opening of  $8 \text{ mm} \pm 2 \text{ mm}$  ( $0.315 \text{ in.} \pm 0.08 \text{ in.}$ ) larger on all sides than the test specimen.

9.1.5.4 For specimens that require footers, the test specimens shall be erected (including those cast in place) on footings, and either back-braced or capped with a simulated roof or ceiling panel to ensure that the bracing or capping reflect standard fielded conditions.

## 10. Specimen Preparation and Mounting

10.1 *Glazing System Tests*—The test specimen will be mounted in accordance with the manufacturer's recommendations and shall be securely anchored. Consideration should be given to, but is not limited to:

- 10.1.1 Overall size of glazing system;
- 10.1.2 Amount of "bite" within the frame;
- 10.1.3 Integrity of the frame;
- 10.1.4 Strength of base material;
- 10.1.5 Size of removable stop;
- 10.1.6 Removable stop fastener;
- 10.1.7 Interface between glazing and frame; and
- 10.1.8 Integrity of anchorage of glazing system to adjoining architectural features.

NOTE 2—The clamping pressure has relatively little effect on the test results for glass but can have considerable influence on the test results for plastic glazing sheet materials. For these materials, the manner of support and retention shall be reported.

10.2 The specimen shall have an edge support/coverage on all edges of  $38 \text{ mm} \pm 6 \text{ mm}$  ( $1.5 \text{ in.} \pm 0.25 \text{ in.}$ ). The specimen shall be separated from the frame and the clamping plate by continuous rubber strips,  $5 \text{ mm} \pm 0.5 \text{ mm}$  ( $0.197 \text{ in.} \pm 0.02 \text{ in.}$ ) thick,  $30 \text{ mm} \pm 5 \text{ mm}$  ( $1.18 \text{ in.} \pm 0.197 \text{ in.}$ ) wide and of hardness ( $50 \pm 10$ ) IRHD, in accordance with Test Method D1415.

NOTE 3—The rigidly supported fixture prevents specimen translation along the line of flight but permits its position and attitude to be readily adjusted so that it is perpendicular to the line of flight at the projectile point of impact.

10.2.1 The test specimen in the frame shall be placed normal to the direction of attack with an accuracy of  $\pm 0.02$  radians ( $\pm 1^\circ$  (degree)) in any orientation. Test specimen shall be oriented to strike face in accordance with manufacturer's documentation. Manufacturer shall clearly mark the strike face on each specimen. The support and retention system shall be reported.

## 11. Calibration and Standardization

11.1 Apparatus shall be inspected for defects prior to testing, be in good working condition and not defective.

11.2 Velocity of the ballistic firing mechanism shall be verified.

11.2.1 *Velocity Measurement System*—The velocity measurement system shall be capable of providing projectile velocities with at least a  $1 \times 10^{-6}$  sec sampling resolution and an accuracy of at least  $\pm 1.5 \text{ m/s}$  ( $\pm 5 \text{ ft/s}$ ). The system shall maintain position and alignment throughout the testing sequence and shall minimize the effects of shock waves, sound waves, ultraviolet and infrared light, ejected propellant, sabots, and other debris that can decrease measurement accuracy. Redundant velocity measurement system is required.

11.2.2 If radar, high-speed video, or X-ray is used for velocity measurement, the velocity reported shall be the velocity measured at  $2.3 \text{ m} \pm 2.5 \text{ cm}$  ( $90 \text{ in.} \pm 1.0 \text{ in.}$ ) from the plane of the test item.

11.2.3 If light screens are used for velocity measurement, the requirements below shall be met.

11.2.3.1 The light screens shall be positioned as shown in Specification E3062/E3062M.

11.2.3.2 The inner screens shall be paired together, and the outer screens shall be paired together.

11.2.3.3 The light screen pairs shall be parallel to each other and perpendicular to the projectile firing system barrel.

11.2.3.4 The distance from the last light screen to the test item reference plane shall be no greater than  $1.5 \text{ m}$  ( $5 \text{ ft}$ ).

11.2.3.5 The light screens shall be fastened together to prevent inadvertent changes in spacing.

NOTE 4—The spacing between the light screens may be adjusted to meet velocity measurement requirements.

11.3 Impactor weight shall be verified to be  $45 \text{ kg} \pm 1 \text{ kg}$  ( $100 \text{ lb} \pm 2 \text{ lb}$ ).

11.4 Impactor nose cone shape and dimensions shall be verified through measurement, free of gouges or cuts deeper than  $12 \text{ mm}$  ( $0.5 \text{ in.}$ ), and durometer shall be an average of  $80 \pm 10$  Shore D when measured in three distinct locations on the

nose cone, with a minimum of one location being at the center of the impacting face of the nose cone.

## 12. Conditioning

12.1 Specimens shall be conditioned prior to testing to ensure all components have reached temperature equilibrium.

12.2 Testing shall be performed at an ambient temperature of  $22\text{ }^{\circ}\text{C} \pm 4\text{ }^{\circ}\text{C}$  ( $72\text{ }^{\circ}\text{F} \pm 7\text{ }^{\circ}\text{F}$ ).

## 13. Test Director Role

13.1 The Test Director is responsible for safety and will ensure that all reasonable safety precautions are employed.

13.2 *Safety*—The test may be interrupted for reasons of safety (imminent danger to or injury of test personnel). This interruption in the test will not be used for clearing away debris, such as glass fragments produced during testing, from the test specimen. *Any modifications to the test specimen made for safety reasons must be agreed to by all parties* and must not in any way enhance or detract from the sample's forced-entry resistance.

13.3 The Test Director's goal is to ensure consistency in the application and performance of this test. The Test Director shall direct impacts and verify the system to the pass/fail criteria presented in this document. The Test Director shall be provided a full set of plans prior to the test.

13.4 The Test Director shall, at a minimum, ensure the following:

13.4.1 Only those resources (impactor) specified may be applied to the test specimen once forced-entry testing has commenced;

13.4.2 Impactor and firing device are used safely and appropriately; and

13.4.3 The elapsed time between the weakening of the glazing and impact commencing shall be minimized and shall in no case exceed 2 h in order to simulate actual durations of attack as closely as possible in a controlled environment.

## 14. Procedure for Panel Operability

14.1 Prior to any testing of the system, the system shall have its operability measured and recorded. No assembly shall be modified or enhanced once operability has been recorded.

14.2 Additional attachments that increase the strength of the connection between the operable locking devices and the system are not permitted. Operation of the locking devices shall be done in a manner that will not cause collateral damage to the specimen.

### 14.3 Panel Operability Test:

14.3.1 This test applies only to systems that may be opened.

14.3.2 Close and lock all portions of the test specimen. Submit each operable unit to five cycles of opening, closing, and locking prior to testing.

14.3.3 After panel operation test sequence, the test specimen shall be considered operable per the manufacturer's written installation instructions.

14.3.4 Fenestration shall be locked prior to initiating any test projectile firings and the locks not operated again until the completion of the forced entry impactor tests.

14.3.5 At the completion of the final forced entry impact test sequence, the operability of the system shall be verified in accordance with Section 14; however failure to operate is not a condition of passing this test. The ability to operate the locks and open the system shall be noted in the report.

## 15. Procedure for Fenestration Weakening

### 15.1 Glazing or Panel Weakening:

15.1.1 Glazing or panel shall be pre-weakened by test projectiles prior to impact testing.

15.1.2 Test pattern shall be centered on the target component (normally geometric center of the glazing or panel) with a minimum distance from the inner edge of the frame being 52 mm (2 in.).

15.1.3 Test pattern diameter shall be  $457\text{ mm} \pm 6\text{ mm}$  (18 in.  $\pm 0.25$  in.) with all the impacts being positioned within the tolerance of the diameter with  $0.785\text{ radian} \pm 0.05\text{ radian}$  ( $45^{\circ} \pm 3^{\circ}$ ) separation between shots. The center shots (C1 and C2) shall be located  $52\text{ mm} \pm 6\text{ mm}$  (2 in.  $\pm 0.25$  in.) from the geometrical center and along the *W* to *E* axis with  $104\text{ mm} \pm 6\text{ mm}$  (4 in.  $\pm 0.25$  in.) distance between the center of each shot.

15.1.4 *Test Projectile Firing*—Ammunition of the appropriate type and caliber (see 6.5) shall be single-fired to obtain the required number of fair hits on each test specimen. Shots shall utilize the shot pattern shown in Fig. 4.

15.1.5 The sequence of projective firing shall be *N, S, W, E*, followed by *NW, SW, NE, SE*, C1 and C2 as indicated in Fig. 4.

15.1.6 The orientation and sequence of the shots shall not be changed.

### 15.2 Procedure for Lock Weakening:

15.2.1 Lock mechanisms in doors shall be pre-weakened by test projectiles prior to impact testing.

15.2.2 Test pattern shall be offset (to the right or left) of the locking mechanism so that the applicable *West* or *East* most firing impacts the center of the lock with the remaining shots on the door panel (Fig. 7).

15.2.3 Test pattern diameter shall be  $229\text{ mm} \pm 6\text{ mm}$  (9 in.  $\pm 0.25$  in.) with all the impacts being positioned within the tolerance of the diameter with  $1.571\text{ radian} \pm 0.05\text{ radian}$  ( $90^{\circ} \pm 3^{\circ}$ ) separation between shots. The center shot (C3) shall be located to the side (right or left) and perpendicular to the vertical center of the locking mechanism (typically a panel impact location).

15.2.4 *Test Projectile Firing*—Ammunition of the appropriate type and caliber shall be single-fired to obtain the required number of fair hits on each test specimen. Shots shall utilize the shot pattern shown in Fig. 5.

15.2.5 The sequence of projective firing shall be C3, followed by *N, S, E, W* as indicated in Fig. 5. The final shot shall be on the lock mechanism.

15.2.6 The orientation and sequence of the shots shall not be changed.

15.3 *Fair and Unfair Hits*—For purposes of this test method, a fair hit shall be a zero-degree obliquity ballistic impact ( $\pm 3^{\circ}$ ) using the specified weight and type of un-yawed

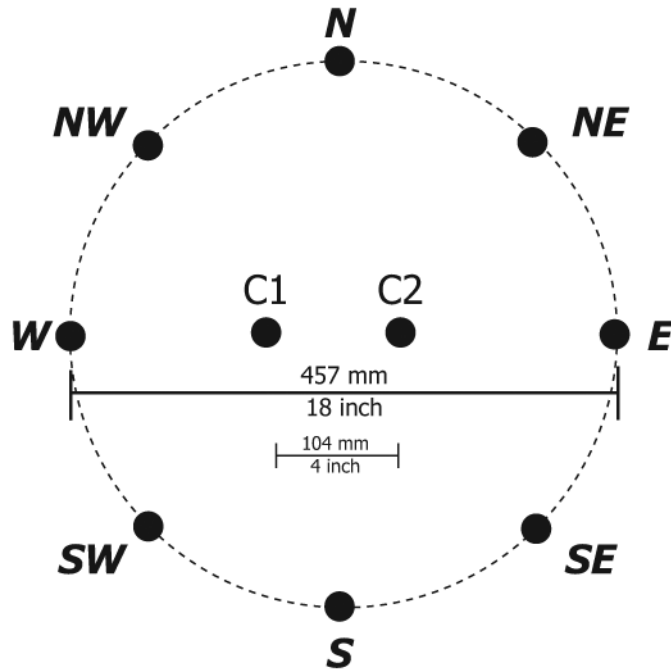

FIG. 4 Test Projectile Firing Pattern for Glazing and Panels

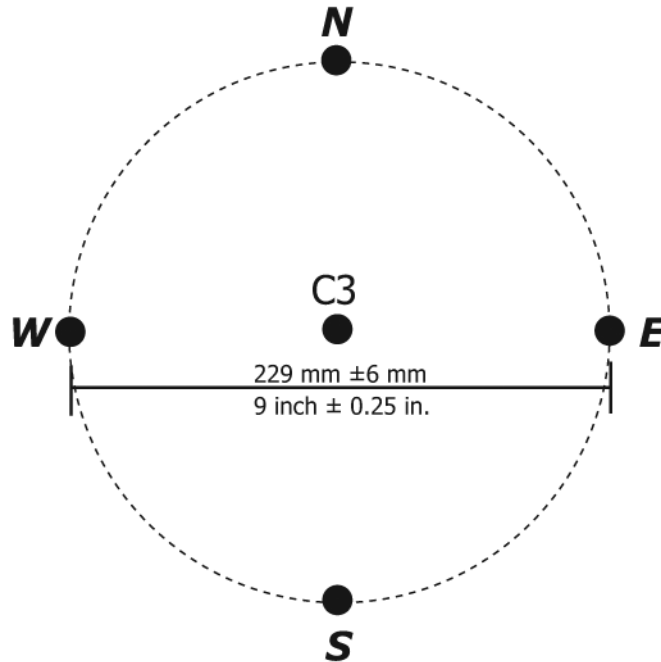

FIG. 5 Test Projectile Firing Pattern for Door Locking Mechanism

bullet (0.05 radian (3°) maximum)) within the specified velocity range on the specified location of the test sample. Yaw is measured at the point of impact but no further than 300 mm (12 in.) from the front surface of the specimen. All other firings shall be classified as unfair, and require retesting, except:

15.3.1 An impact at more than the maximum acceptable velocity which does not cause panel perforation, but which is

otherwise a fair hit, shall be classified as a fair hit at the discretion of the manufacturer.

15.3.2 In the case of an unfair hit, at the discretion of the manufacturer, select one of the following to continue testing:

15.3.2.1 Restart the pattern on a new sample; or

15.3.2.2 Fire a replacement shot that is closer to the intended pattern than the unfair hit.



15.3.2.3 Restarting the pattern is limited to only one specimen per sample set.

15.4 Evaluate glazing for passage of test shape at any time during the test projectile firing pattern when the Test Director believes passage for failure is possible.

15.4.1 No additional damage may be done to the glazing system, including hand manipulation of fragments when evaluating test shape passage.

## 16. Procedure for Forced-Entry Testing

16.1 Forced-entry testing, regardless of the type of assembly being tested, shall consist of glazing weakening followed by mechanical forced-entry impacts.

16.2 The impact assault will be at the center of the glazing or panel.

16.3 The impact assault for the lock shall be centered on test projectile shot C3 of [Fig. 5](#).

16.4 *Designate Forced-Entry Test Force Level:*

16.4.1 Target force shall be selected from [Table 2](#).

16.5 Perform the impact assault testing for the selected resistance force on each dissimilar component.

16.5.1 With the impactor at rest, the furthest protruding point of the impacting nose cone shall be located no more than 52 mm (2 in.) from the surface of the specimen and no more than 52 mm (2 in.) in any direction from the intended impact location on the specimen.

16.5.2 Align the impactor with the impact position as required. Raise the impactor to the selected drop height intended for classification and stabilize it. At the selected drop height, the suspension device shall be taut, and the axes of the impactor and cable shall be in line.

16.5.3 The impactor, stabilized in the launch position in a vertical plane normal to the test specimen, is released and falls without initial velocity or axial rotation.

16.5.4 Inspect each test specimen after each impact and record and report whether it complied or did not comply with the applicable interpretation of results.

16.5.5 Impacts start at the lowest drop height from [Table 1](#) and advance through each level by successively increasing the drop height until the target level or failure is reached.

16.5.5.1 The test specimen must pass two (2) sequential impacts from the same drop height for it to be deemed a pass at that level, or to move on to a higher level.

16.5.6 Specimens may be reused for higher classification impact testing.

16.5.7 For systems with bent glass, each specimen of bent glass will be impacted on the convex surface at the center of the specimen perpendicular to the frame from the selected drop height.

NOTE 5—The convex surface is tested due to the realistic constraints of the test set-up in impacting the concave surface. Additionally, as of the date of this publication no data was available that showed one surface is more or less likely to break during impact.

16.5.8 Conduct forced-entry testing at each component until one of the following conditions is met:

16.5.8.1 The system fails due to any of the criteria in [Section 18](#); or

16.5.8.2 The selected forced-entry resistance level is met without failure.

(1) The force level is considered a pass when all locations designated for impact on a system in accordance with [Section 17](#) are passed successfully at the same force level.

16.5.9 If any of the required specimens fail to comply with the requirements of [Section 18](#), the material shall not be classified for forced-entry impact.

16.6 No repairs or replacement of damaged components are permissible during or between any glazing weakening or forced-entry tests.

## 17. Attack Types

17.1 A test specimen shall be tested at all dissimilar components via a separate concentrated assault. Every dissimilar portion (section) is tested for at least as long as the intended rating of the system as a whole. To achieve the intended system rating, every dissimilar component must deny forced entry for that test sequence.

17.2 *Door Attack Type:*

17.2.1 Perform individual testing on three separate test specimens. Each assault should be the same force as the desired forced entry resistance level. Use two door systems for glazing weakening and impact, and one door system for lock weakening and impact. Perform forced-entry impact assault on the door panel or glazed areas ([Fig. 6](#)), and one lock weakening and forced entry impact on the latch/lock area ([Fig. 7](#)) only. The test projectiles shall be fired to impact the door and offset (to the right or left) from the lock so that the applicable *West* or *East* most projectile impacts the center of the lock (see [Fig. 7](#)). The attack direction shall be from exterior to interior independent door seating.

17.2.1.1 The door will qualify at the lowest level of forced entry determined from either the glazing or lock assault testing.

17.2.1.2 At the request of the manufacturer, the forced entry assault of the glazing and the lock weakening forced entry assault may be performed on each sample, however the intent is to use three specimens, two for the glazing assault and one for the lock assault.

17.2.1.3 For double door systems, the assault is only performed on the main locking system and not the point lock locations.

17.2.2 A double-door must be tested in its double-door configuration. Additional impact attacks should be conducted at the mid-span of the center whether a mullion is present or not ([Fig. 8](#)). If doors contain glazing, they must additionally be impacted per the window attack type that follows. Symmetrical construction features do not need to be tested more than once.

17.3 *Window Attack Type:*

17.3.1 Perform a minimum of two separate forced-entry impact assaults on a window at the same impact level. Impact drop height starts at the lowest level and progresses to higher drop heights after two successful impacts at the same height. Perform the assault at the center of the glazing ([Fig. 9](#)).

17.4 *Panel Attack Type:*

17.4.1 Perform a minimum of three separate forced-entry impacts on a panel. Perform at least one impact at the center of

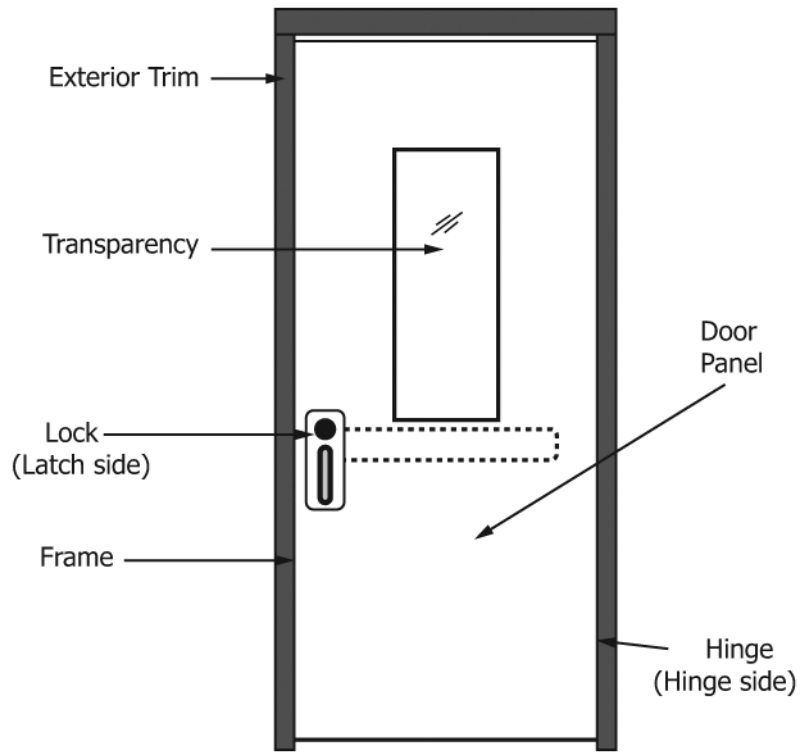
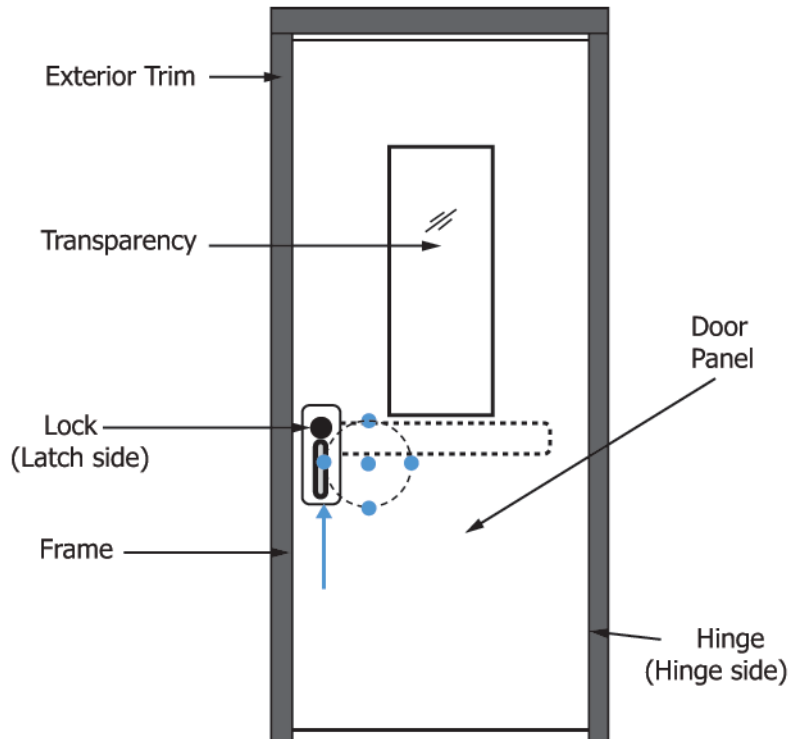

FIG. 6 Descriptors for Single Door Attack Sequence



NOTE 1—West most impact indicated by arrow.

FIG. 7 Descriptors for Single Door Test Projectile Impacts

the panel (Fig. 10), at least one impact at the corner of the panel (Fig. 10), and one impact at the panel frame pocket (Fig. 10).

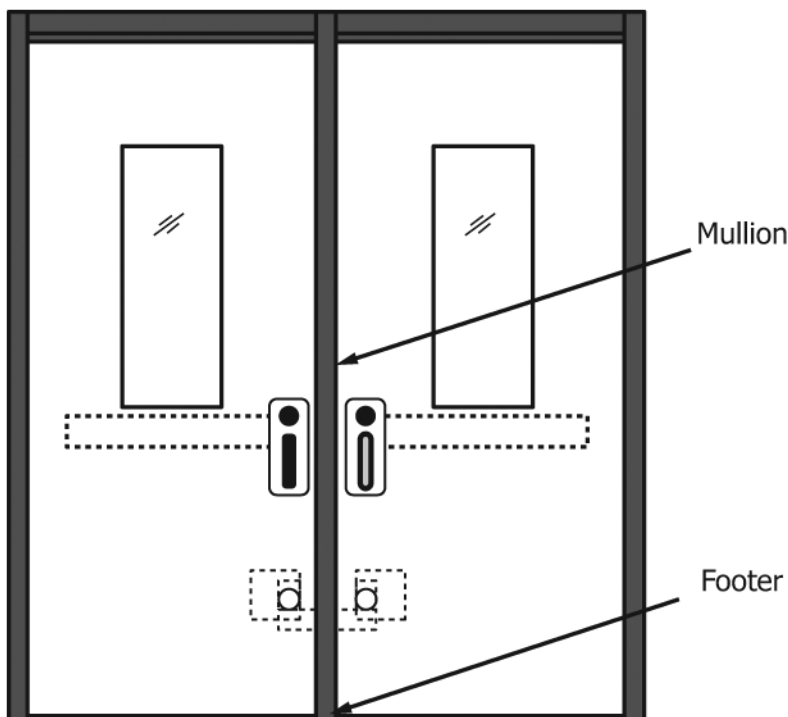

FIG. 8 Descriptors for Double Door Attack Sequence

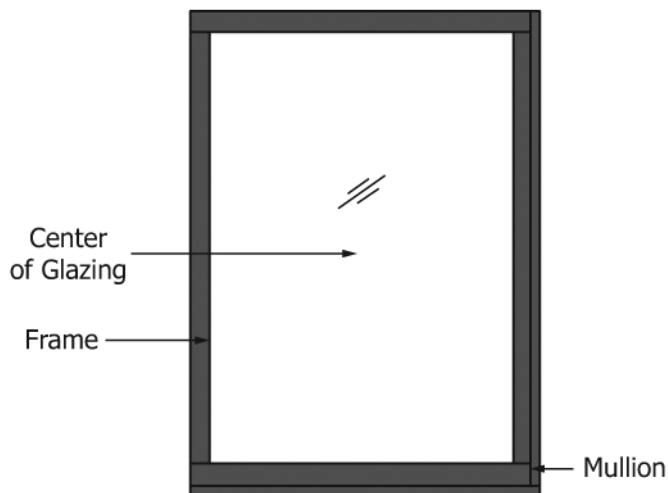

FIG. 9 Descriptors for Window Attack Sequence

**18. Forced-Entry Pass Criteria**

18.1 The goal of the testing is to determine system capability in preventing the development of an opening in the test plane that allows passage of the test shape after weakening or impact. The testing is considered a pass if all the following criteria are met:

18.1.1 The test shape cannot be passed entirely behind a plane parallel and contiguous to the face of the attack side of the test specimen by a single attack team member, using only their hands to guide the test shape and a force meter. No greater than 18 N (4 lb) force shall be exerted on the test shape at any time during or at the end of glazing weakening testing or forced entry impact testing to pass it through an opening.

18.1.1.1 Operable systems that open upon glazing weakening or impact testing and allow passage of the test shape are not considered a pass.

**19. Interpretation of Results**

19.1 After all of the test sequences have been completed, the system will be assigned a “Fail” rating or a “Pass” rating with an associated forced-entry rating level.

19.2 System is assigned a Fail rating if it does not meet all of the criteria in Section 18.

19.3 System is assigned a Pass rating with a system forced-entry rating that is equal to the lowest “pass” force of all of the individual test specimens.

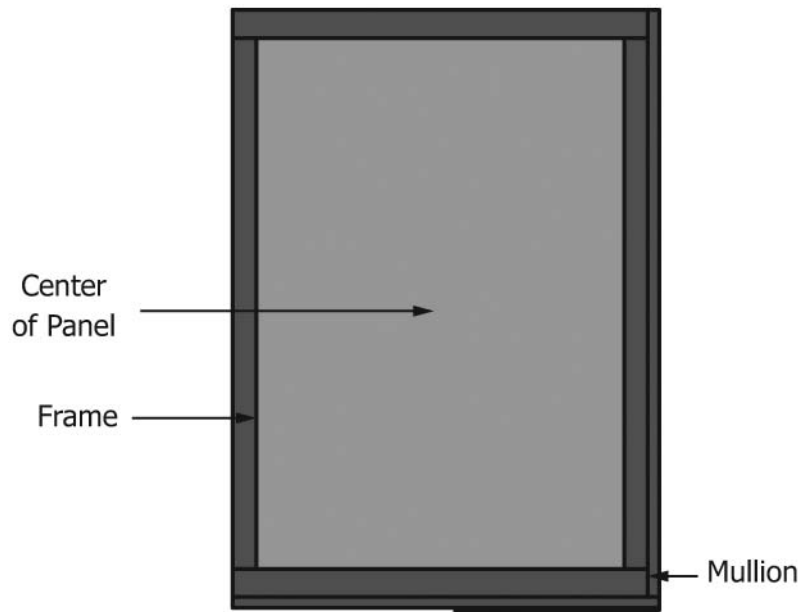

FIG. 10 Descriptors for Panel Attack Sequence

19.4 *Substitution Criteria*—See [Annex A1](#).

**20. Report**

*20.1 General Test Data Reporting Procedure:*

20.1.1 Once a system is tested according to this test method, a final report of all testing results shall be submitted to the requisitioner regardless of testing outcome. All test reports as well as any information concerning the results of each test are considered proprietary and shall not be discussed or released without prior approval of the requisitioner and the manufacturer.

*20.1.2 Test Report Requirements:*

20.1.2.1 The testing laboratory will provide the requisitioner with a testing report that shall be an all-inclusive document with the data and results of all testing, as well as all other documentation required by this section. This includes the configuration documentation, any applicable abnormalities, panel operability results, glazing weakening details and results, forced-entry data, testing photographs, the certification of testing, the narrative summary of testing, and all video recording(s) of testing.

20.1.2.2 *Report Title and General*—The title of the report shall contain:

- (1) Indicate the type of report, that is “Test Report;”
- (2) The system model number, level of forced-entry resisted as defined by forced-entry resistance testing levels;
- (3) Date, time, and location of testing; and
- (4) Temperature of laboratory during testing, specimen surface temperature.

*20.1.2.3 Configuration Documentation:*

(1) The report shall contain complete configuration documentation including drawings that have been validated to match the test specimen and a list of materials not otherwise described by the drawings. Comments concerning inconsistencies between the assembly and its documentation shall be expressed in the testing report.

*20.1.2.4 Panel Operability Data:*

(1) Include detailed results and discussion of the panel operability test (where applicable).

*20.1.2.5 Glazing Weakening Data:*

(1) Include detailed results and discussion of the glazing weakening performance including any deviation from the pattern, abnormal breakage, and any openings that developed.

*20.1.2.6 Forced-Entry Test Data:*

(1) Include detailed data records of forced-entry testing including impactor details, drop height, calculated or measured force, and if applicable, penetration details with opening size measurements before test shape evaluation, then test shape penetration results and the overall results of forced-entry testing.

*20.1.2.7 Photographic Record of Testing:*

- (1) Submitted as 5 megapixel resolution (minimum) digital photographs of the test specimen:
- (2) Before testing;
- (3) After all glazing weakening shots have been completed;
- (4) After each level of forced-entry impact; and
- (5) If applicable, the point at which entry is forced.
- (6) Each photo should specify: (1) model number (2) a description of the view, (3) the test phase description, (4) glazing configuration (if applicable to photo), and (5) the manufacturer.

*20.1.2.8 Narrative Summary of Testing:*

- (1) A narrative summary shall be provided which includes:
- (2) The identity of the test facility,
- (3) A description of the sample,
- (4) A description of the testing,
- (5) A description of the results, and
- (6) A detailed explanation of any conditions (for example, test temperature, glazing size) that do not meet the requirements of this test method.

*20.1.2.9 Video Recording of Testing:*

(1) All forced-entry testing shall be recorded in its entirety. Video recording(s) shall be provided to the requester in the form of physical or electronic media. The recording(s) shall include appropriate audio narrative description and comments. Acceptable file formats for these videos are: Audio Video Interleave (.avi file extension), Windows Media Format (.wmv file extension), and Moving Pictures Expert Group (.mpg or .mpeg file extensions). Include the date, location, and description of testing as the title of the video files. There shall be no restrictions on use of video with the exception of test lab anonymity if required by the test lab. In the event anonymity is desired, the test lab shall ensure all identifying materials (that is: logos, lab names, location) are excluded from the video to allow requisitioner full use of the video or portion thereof.

## 21. Precision and Bias

21.1 Forced-entry system testing shall be thorough, and each dissimilar component of a system should be tested

separately. The precise scientific identification and reproduction of a forced entry threat in the field is not possible. However, forced entry testing provides a valuable baseline for evaluating systems and this method offers a way to standardize mechanical resistance testing for forced-entry-resistant systems. No information is presented about either the precision or bias of this test method since the test results are nonquantitative.

## 22. Keywords

22.1 active shooter; doors; forced-entry (FE); façade; glass; glazing; laminated glass, impact; penetration resistance; security; systems; walls; windows

# ANNEX

## (Mandatory Information)

### A1. SUBSTITUTION CRITERIA

#### A1.1 Introduction:

A1.1.1 Substitution allowances are presented in the following text. There are three types of substitutions for fenestration assemblies qualified under this standard: (1) substitutions of infill elements, (2) substitutions of anchorage, and (3) substitutions of all other elements.

A1.1.2 The substitution criteria in **Annex A1** are related to glass weakening and impact performance only as found in this test method and does not qualify systems for other performance attributes.

A1.1.3 The substitution language applies to panels, windows, and doors of all types.

#### A1.2 Substitution Categories:

A1.2.1 *Automatic*—No additional testing or analysis necessary.

A1.2.2 *Engineering Analysis*—Demonstrated or documented performance through a review of materials that predicates a minimum of equivalent performance.

A1.2.3 *Single Specimen*—One specimen, identical to the original specimens qualified, with the only difference being the elements to be substituted.

A1.2.4 *Not Allowed*—Not qualified by testing of a single specimen. Three identical specimens out of four are required to qualify the substitution, as for a new product.

#### A1.3 General Premises for Substitution:

A1.3.1 Substitutions are only allowed to assemblies that have initially qualified by having three initial specimens that are identical in every way, excluding anchorage and mounting, pass all the prescribed performance requirements of this test method.

A1.3.2 Successful testing of smallest and largest assemblies identical in every way except size allow all sizes between to be automatically qualified, provided (1) no single dimension is less than or greater than those qualified in the three initial specimens tested at each size, (2) the overall area of the originally tested specimens is not exceeded, and (3) the rating of the originally tested specimens is not exceeded. Engineering analysis or testing of additional specimen sizes can be conducted to override these limitations.

#### A1.3.3 Anchorage:

A1.3.3.1 Each method of anchoring shall be qualified by testing a single specimen in the condition that produces the greatest load on the anchoring method or qualified by engineering analysis.

A1.3.3.2 Any substitution of the fastener within an anchoring method, supported by engineering analysis to be equal to or stronger than the initial qualified fastener, shall be allowed automatically provided the original spacing is not exceeded.



## PREMISES FOR SUBSTITUTION—GLAZED PRODUCTS

### A1.4 *General:*

A1.4.1 When substituting an element on the basis of a single specimen test, select the worst case for impact locations.

### A1.5 *Glazing Sealants, Adhesives, and Backbedding:*

A1.5.1 Substitution of glazing sealants, insulating glass primary or secondary sealants, adhesives, or backbedding color shall require the testing of a single specimen, or when supported by engineering analysis provided the only change from the initial three qualified specimens is a change in the sealant color, and documentation is provided that the nominal specific gravity of the substituted material is  $\pm 0.06\%$  from that used in the initial three specimens, or historic data/documentation is provided showing that different colors perform to the same performance properties that are either within or outside the allowable specific gravity range.

A1.5.2 Any substitution within the fenestration glazing sealant, insulating glass primary or secondary sealants, adhesives, or backbedding demonstrated to be equal to or stronger in ultimate tensile strength as shown in Test Method **C1135** than the initial three qualified specimens, shall require a single specimen test. Substitution of a sealant, adhesive, or backbedding material with a lower movement capability as shown in Test Method **C719** shall not be allowed.

### A1.6 *Glazing Tapes:*

A1.6.1 Substitution of glazing tape color shall require a single specimen test, or shall be supported by engineering analysis provided the only change from the initial three qualified specimens is a change in the tape color, as follows:

A1.6.1.1 For preformed tapes, documentation is provided that the nominal specific gravity of the substituted material is  $\pm 0.06\%$  from that used in the initial three specimens, or historic data/documentation is provided showing that different colors perform to the same performance properties that are either within or outside the allowable specific gravity range.

A1.6.1.2 For foam tapes, documentation is provided that the specific gravity, as determined by Test Methods **D3575**, does not differ by more than  $\pm 20\%$  from that used in the initial three specimens.

A1.6.2 Any substitution within the fenestration glazing tapes demonstrated by an applicable reference standard to be equal to or stronger than the initial three qualified specimens shall require a single specimen test.

### A1.7 *Glass Plies:*

A1.7.1 Glass color change shall be allowed automatically.

A1.7.2 Substitution or adding of glass coating (reflective, coated, low-e, frit, and so forth) shall be allowed when supported by engineering analysis of the durability and compatibility of the treatment with glazing infill, interlayer, and sealant, adhesives, or back-bedding materials.

A1.7.3 For any non-sacrificial lite, individual glass ply thickness increase shall require the testing of a single specimen.

A1.7.4 A substitution with a decrease in glass ply thickness beyond the minimum thicknesses of Specification **C1036** shall not be allowed.

A1.7.5 For any non-sacrificial lite, any of the following glass type changes shall require a single specimen test (see **A1.8.1.4**, **A1.8.2.2**, **A1.8.2.3**, and **A1.8.2.4** for sacrificial lites):

A1.7.5.1 Annealed to heat-strengthened.

A1.7.5.2 Annealed to chemically-strengthened.

A1.7.5.3 Annealed to fully tempered.

A1.7.5.4 Heat-strengthened to fully tempered.

A1.7.5.5 Chemically-strengthened to fully tempered.

A1.7.6 Glass type change from heat-strengthened to annealed or heat-strengthened to chemically-strengthened shall not be allowed.

A1.7.7 Glass type change from fully tempered to heat-strengthened, chemically-strengthened, or annealed shall not be allowed.

A1.7.8 Glass decorative surface (sandblasted, acid etched, and so forth) substitution shall require a single specimen test.

### A1.8 *Insulating Glass Units:*

A1.8.1 *Preconditions for Insulating Glass Unit Substitutions:*

A1.8.1.1 The impact resisting lite (monolithic or laminated) of an insulating glass unit shall be composed of the same glass type and treatment with equal thickness or thicknesses of glass, and thicker or equal interlayer of the same manufacturer and type as originally tested and approved.

A1.8.1.2 The glazing detail (glazing sealants, adhesives, stops, etc.) shall be unchanged other than to accommodate any variations in overall glazing thickness.

A1.8.1.3 Substitutions for insulating glass shall only be made for systems with the impact resistant glazing structurally adhered to the frame or sash glazing leg or bed, in the same manner and position as originally tested and approved.

A1.8.1.4 In an insulating glass unit, typically one lite provides the impact resistance (usually a laminated lite) and the other lite is considered to be “sacrificial.” This sacrificial lite can fracture without detriment to the impact resistant lite which is providing the actual building envelope protection.

A1.8.1.5 Glazing systems typically have a stationary glazing stop that is a permanent part of the frame or sash, or a removable glazing stop (also referred to as a glazing bead), or both. If a removable stop is used, a system can be tested with this stop removed if it is considered to be non-structural and unnecessary to pass the required test.

A1.8.2 *Systems Tested with a Removable Glazing Stop or Bead in Place:*

A1.8.2.1 Any substitution to an insulating glass unit from a single glazing (monolithic or laminated glass) shall require the testing of one additional specimen, provided the system meets all the preconditions in **A1.8.1**.

A1.8.2.2 Substitutions in glass treatment, specifically and only from annealed to heat-strengthened shall be allowed automatically to sacrificial lites (see **A1.8.1.4**) of insulating glass units, provided the system meets all the preconditions in **A1.8.1**.

A1.8.2.3 Increase in glass thickness shall be allowed automatically to sacrificial lites, providing the system meets all the preconditions in **A1.8.1**.

A1.8.2.4 Reductions in glass thickness in sacrificial lites of insulating glass units shall require a single specimen test, provided the system meets all the preconditions in **A1.8.1**.

A1.8.2.5 Substitutions of a monolithic sacrificial lite with a laminated sacrificial lite shall be allowed automatically in insulating glass units, provided the system meets all the preconditions in **A1.8.1**.

A1.8.2.6 Substitution of a laminated sacrificial lite with a monolithic sacrificial lite shall not be allowed to the sacrificial lite.

**A1.8.3 Systems Tested without a Removable Glazing Stop or Bead in Place:**

A1.8.3.1 Any substitution to an insulating glass unit from a single glazing (monolithic or laminated glass) shall require a single specimen test, provided the system meets all the preconditions in **A1.8.1**.

A1.8.3.2 Substitutions in glass thickness shall be allowed automatically to sacrificial lites (see **A1.8.1.4**) of insulating glass units, provided the system meets all the preconditions in **A1.8.1**.

A1.8.3.3 Substitutions in glass type shall require a single specimen test, provided the system meets all the preconditions in **A1.8**.

A1.8.3.4 Substitutions from a system approved with an insulating glass unit to a monolithic or single laminated unit shall not be allowed.

**A1.9 Insulating Glass Unit Spacers:**

A1.9.1 When the approved system was tested with an insulating glass unit, a change in spacer type, shape, or dimension shall require a single specimen test.

A1.9.2 If the conditions in **A1.8.1.3** are met, a change in spacer type, shape, or dimension is allowed automatically.

**A1.10 Asymmetrical Insulating Glass Unit Orientation:**

A1.10.1 A change in the orientation (order of lites from outboard to inboard) of an asymmetrical insulating glass unit from the approved orientation shall not be allowed.

**A1.11 Interlayer Type or Brand:**

A1.11.1 Any substitution of interlayer color from the same manufacturer and type as was originally qualified shall be allowed automatically.

A1.11.2 Any substitution of interlayer decorative treatment from the same manufacturer and type as was originally qualified shall be allowed automatically, provided the decorative treatment does not contact the glass or plastic glazing.

A1.11.3 Any increase of the interlayer thickness by any amount, provided it is the same manufacturer and type as was originally qualified, shall be allowed automatically.

A1.11.4 Any substitution of interlayer type shall not be allowed.

A1.11.5 Provided the interlayer type and thickness remain the same (see **A1.11.6**), any substitution of interlayer manufacturer shall require a single specimen test.

A1.11.6 A decrease of the nominal interlayer thickness as was originally qualified is not allowed.

## PREMISES FOR SUBSTITUTION—FRAMING MATERIALS

**A1.12 General:**

A1.12.1 Any substitution of framing materials shall require a single specimen test.

A1.12.2 The substitution profile section moduli and moments of inertia must be greater than or equal to the original profile tested as evaluated in accordance with standard engineering practices.

A1.12.3 Any substitution within the material of the framing, sash, panel, or door leaf must maintain the same glazing design, detail, and glass bite as originally tested.

**A1.13 Sliding-Projected-Dual Action Windows; Sliding Doors; and Hinged Doors Consisting of Sliding Door and Window Panels, Fixed Panels of Door or Window Assemblies, Window Sash, Window Vents, and Hinged Door Leaves:**

A1.13.1 Any substitution within the operable window or operable door assembly shall meet the requirements of **A1.12** and **A1.2.2**, and shall require a single specimen test.

**A1.13.2 Rolling, Sliding, and Hinging Hardware—**Any substitution within the operable window or operable door assembly of operation hardware shall require the testing of one additional specimen. A reduction in the number of operation points (for example, butt hinges, pivots, casters, and so forth) shall be allowed automatically, provided the center-to-center and edge-to-center spacing between operation points is not exceeded. The addition of operation points over and above the number originally tested shall be allowed when supported by engineering analysis as stated in **A1.2.2**.

**A1.13.3 Locking Hardware for Sliding-Projected-Dual Action Windows, Sliding Doors, and Hinged Doors—**Any substitution within the operable window or operable door assembly

of locking hardware shall require a single specimen test. A reduction in the number of lock points shall not be allowed. The addition of locking points over and above the number originally tested shall be allowed when supported by engineering analysis as stated in [A1.2.2](#).

**A1.14 Storefront Framing, Curtain Walls, Fixed Windows, and Mullions:**

**A1.14.1 Framing Members**—Any substitution within the framing or fixed window assembly, vertical or horizontal mullion profile shall meet the requirements of [A1.12.2](#), [A1.3](#), and [A1.2.2](#) or require a single specimen test.

**A1.15 Skylight and Roof Windows:**

**A1.15.1 Hinging Hardware**—Any substitution within the fenestration assembly of hinging hardware shall require a single specimen test.

**A1.15.2 Locking Hardware**—Any substitution within the fenestration assembly of locking hardware shall require a single specimen test.

## APPENDIX

### (Nonmandatory Information)

#### X1. GLAZING ONLY WEAKENING TESTING—NON-SYSTEM TEST

**X1.1 General:**

**X1.1.1** This test allows for glazing configurations to be evaluated according to the requirements of Test Method F3561, without incorporating the glazing configuration in a specific system.

**X1.1.2** Glazing evaluation by these methods does not allow for direct substitution without testing a full system.

**X1.1.3** The following test methods are pre-evaluation for glazing configurations, not pre-qualification or certification. Results are to be used to assist in glazing selection for system tests.

**X1.1.4** Glass shall comply to Specifications [C1036](#), [C1048](#), and [C1172](#) as applicable.

**X1.1.5** The glazing shall be square and at least 610 mm × 610 mm ± 12 mm (24 in. × 24 in. ± 0.5 in.).

**X1.1.6** The glazing specimens shall be conditioned per Section [10](#).

**X1.1.7** For asymmetric materials, the test shall be carried out on both sides using equal numbers of separate specimens.

**X1.2 Glazing Material Support System:**

**X1.2.1** Unframed glazing samples will be mounted in a test frame similar to that which is detailed in [Fig. X1.1](#). A weldment constructed of structural steel angle iron (conforming to Specification [A36/A36M](#) for 150 mm × 90 mm × 160 mm (6 in. × 3.5 in. × 0.625 in.)) which has a 3 cm<sup>2</sup> (1.25 in.<sup>2</sup>) steel bar fixed stop (conforming to Specification [A36/A36M](#) for 3 cm<sup>2</sup> (1.25 in.<sup>2</sup>)) which will accept a square test sample of minimum 610 mm × 610 mm (24 in. × 24 in.), and will allow 6 mm (0.25 in.) clearance on all edges. The fixed stop square bar will be oriented to support the entire periphery of the sample facing the protected side for a maximum distance of 25 mm (1.0 in.) from its edge.

**X1.2.2** The test sample will rest at the bottom on two setting blocks 6 mm × 100 mm (0.25 in. × 4 in.) sample thickness of

60 to 80 durometer placed at the quarter points. Prior to inserting the glazing sample in the test frame, a 5 mm (0.188 in.) glazing tape shall be applied to the fixed stop and adjustable stop where contact is made with the test sample.

**X1.2.3** The mounting is completed by bolting the adjustable stop to the test frame with 13 mm (0.5 in.) socket head cap screws (conforming to Specification [A574](#)) torqued to 163 N·m ± 14 N·m (120 ft·lbf ± 10 ft·lbf) each. The center to center location of adjustable stop mounting bolts shall be no greater than 150 mm (6 in.). When the test sample is mounted it will be centered in the test frame and positioned with neoprene shims to result in not more than 25 mm (1.0 in.) edge coverage (bite) of the test sample.

**X1.2.4** Compression of the glazing tape will be made by the adjustable stop, but not to allow a test sample face to stop clearance of more than 3 mm (0.125 in.).

**X1.2.5 Number of Samples**—All testing is done on a minimum of three (3) samples.

**X1.3 Glazing Weakening—Method A:**

**X1.3.1** Glazing shall be assaulted with test projectiles per Section [15](#).

**X1.3.2** To determine drop height capability of glazing, impacts shall be performed in accordance with Section [17](#) on the same specimen that has passed [X1.3.1](#).

**X1.3.3 Interpretation of Results**—Glazing shall be evaluated and reported as pass/fail in accordance with Sections [18](#) and [19](#).

**X1.4 Glazing Weakening—Method B:**

**X1.4.1 Hole Generation Mechanism**—For use in glazing pre-evaluation testing only.

**X1.4.2** Use an appropriate tool capable of producing 6 mm holes which penetrate through the entirety of the glazing construction.

**X1.4.2.1** Holes may be drilled, water jet cut, or similar.

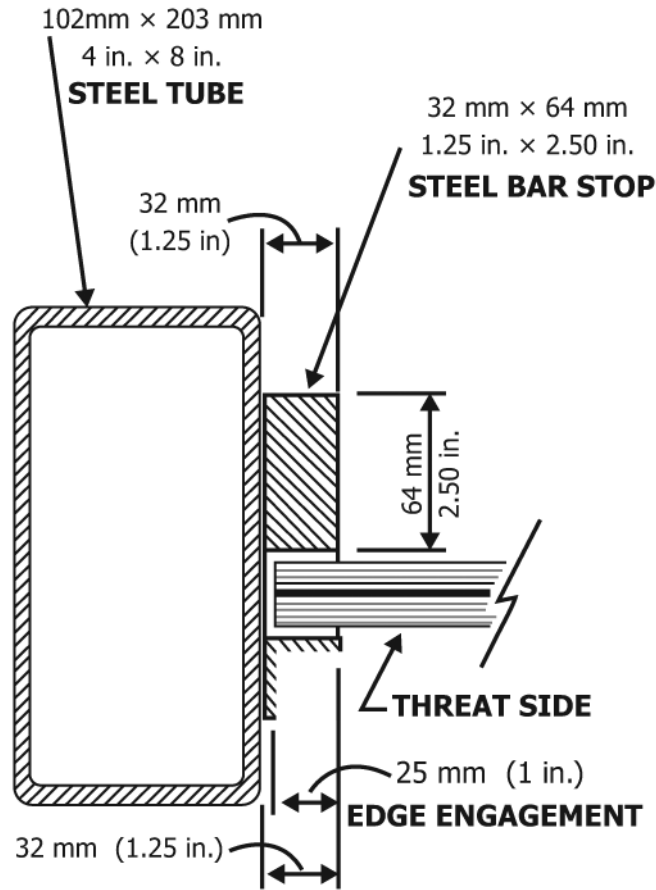

JAMB DETAIL

NOTE: HEAD AND SILL ASSEMBLY SIMILAR

FIG. X1.1 Glazing Material Test Frame

NOTE X1.1—Holes simulate complete penetration of the test projectile without the facility, verification, and safety concerns related to projectile firing in a laboratory environment.

X1.4.2.2 Holes shall have the same number and geometry as those discharged from the test projectile firing equipment (Fig. 4).

X1.4.2.3 For laminated glazing constructions, the hole generation must be completed after lamination.

X1.4.3 Glazing shall be impacted on the same specimen that has been created through X1.4.2.

X1.4.4 A single impact shall be performed in accordance with Section 16, using a 152 mm (0.5 ft) drop height.

X1.4.5 On the same sample passing X1.4.4, determine drop height capability of the glazing by performing impacts in accordance with Section 16.

NOTE X1.2—The first center impact is intended to simulate the cracking around the holes that may not be created with the absence of the test projectile impact.

X1.4.6 Interpretation of Results—Glazing shall be evaluated and reported as pass/fail in accordance with Sections 18 and 19.

X1.5 Report—The report shall contain:

X1.5.1 Title “ASTM F3561 Glazing Only Evaluation – Not Valid for System Test;”

X1.5.2 Method of glass weakening used; and

X1.5.3 Configuration Documentation:

X1.5.3.1 Glazing details including:

X1.5.3.2 Glazing thickness: type (AN, HS, FT, CS or other);

X1.5.3.3 Interlayer thickness: brand and type;

X1.5.3.4 Insulating unit description: overall thickness, spacer details, glazing details, glass ply, and interlayer details;

X1.5.3.5 Glazing weakening details and data;

X1.5.3.6 Forced-entry test details and data;

X1.5.3.7 Photographic record of testing;

X1.5.3.8 Narrative summary of testing; and

X1.5.3.9 Narrative summary of testing, video recording of testing.

*ASTM International takes no position respecting the validity of any patent rights asserted in connection with any item mentioned in this standard. Users of this standard are expressly advised that determination of the validity of any such patent rights, and the risk of infringement of such rights, are entirely their own responsibility.*

*This standard is subject to revision at any time by the responsible technical committee and must be reviewed every five years and if not revised, either reapproved or withdrawn. Your comments are invited either for revision of this standard or for additional standards and should be addressed to ASTM International Headquarters. Your comments will receive careful consideration at a meeting of the responsible technical committee, which you may attend. If you feel that your comments have not received a fair hearing you should make your views known to the ASTM Committee on Standards, at the address shown below.*

*This standard is copyrighted by ASTM International, 100 Barr Harbor Drive, PO Box C700, West Conshohocken, PA 19428-2959, United States. Individual reprints (single or multiple copies) of this standard may be obtained by contacting ASTM at the above address or at 610-832-9585 (phone), 610-832-9555 (fax), or [service@astm.org](mailto:service@astm.org) (e-mail); or through the ASTM website ([www.astm.org](http://www.astm.org)). Permission rights to photocopy the standard may also be secured from the Copyright Clearance Center, 222 Rosewood Drive, Danvers, MA 01923, Tel: (978) 646-2600; <http://www.copyright.com/>*